



Operation Manual

PRODUCT NAME

Digital Pressure Switch

MODEL / Series / Product Number

ZSE30AF-##-X576 ~ X580

SMC Corporation

Table of Contents

Safety Instructions	2
Model Indication and How to Order	8
Summary of Product parts	10
Definition and terminology	11
Mounting and Installation	14
Installation	14
Wiring	16
Pressure Setting	19
Measurement mode	19
Function Setting	22
Function selection mode	22
Default setting	22
F0 Units selection function	24
F1 Setting of OUT1	25
F2 Setting of OUT2	28
F3 Response time	29
F4 Display resolution	32
F5 Auto-preset function	33
F6 Fine adjustment of display value	35
F7 Power saving mode	36
F8 Security code	37
F9 Setting of low-cut function	38
Special function setting	39
F90 Setting of all functions	39
F97 Copy function	41
F98 Check of output	43
F99 Reset to default settings	45
Other Settings	46
Maintenance	49
If the security code is forgotten	50
Troubleshooting	51
Specification	59
Dimensions	62



Safety Instructions

These safety instructions are intended to prevent hazardous situations and/or equipment damage. These instructions indicate the level of potential hazard with the labels of "Caution", "Warning" or "Danger". They are all important notes for safety and must be followed in addition to International Standards (ISO/IEC)*1), and other safety regulations.

*1) ISO 4414: Pneumatic fluid power -- General rules relating to systems.
ISO 4413: Hydraulic fluid power -- General rules relating to systems.
IEC 60204-1: Safety of machinery -- Electrical equipment of machines .(Part 1: General requirements)
ISO 10218: Manipulating industrial robots -Safety.
etc.



Caution

Caution indicates a hazard with a low level of risk which, if not avoided, could result in minor or moderate injury.



Warning

Warning indicates a hazard with a medium level of risk which, if not avoided, could result in death or serious injury.



Danger

Danger indicates a hazard with a high level of risk which, if not avoided, will result in death or serious injury.

Warning

1. The compatibility of the product is the responsibility of the person who designs the equipment or decides its specifications.

Since the product specified here is used under various operating conditions, its compatibility with specific equipment must be decided by the person who designs the equipment or decides its specifications based on necessary analysis and test results.

The expected performance and safety assurance of the equipment will be the responsibility of the person who has determined its compatibility with the product.

This person should also continuously review all specifications of the product referring to its latest catalog information, with a view to giving due consideration to any possibility of equipment failure when configuring the equipment.

2. Only personnel with appropriate training should operate machinery and equipment.

The product specified here may become unsafe if handled incorrectly.

The assembly, operation and maintenance of machines or equipment including our products must be performed by an operator who is appropriately trained and experienced.

3. Do not service or attempt to remove product and machinery/equipment until safety is confirmed.

1. The inspection and maintenance of machinery/equipment should only be performed after measures to prevent falling or runaway of the driven objects have been confirmed.

2. When the product is to be removed, confirm that the safety measures as mentioned above are implemented and the power from any appropriate source is cut, and read and understand the specific product precautions of all relevant products carefully.

3. Before machinery/equipment is restarted, take measures to prevent unexpected operation and malfunction.

4. Contact SMC beforehand and take special consideration of safety measures if the product is to be used in any of the following conditions.

1. Conditions and environments outside of the given specifications, or use outdoors or in a place exposed to direct sunlight.

2. Installation on equipment in conjunction with atomic energy, railways, air navigation, space, shipping, vehicles, military, medical treatment, combustion and recreation, or equipment in contact with food and beverages, emergency stop circuits, clutch and brake circuits in press applications, safety equipment or other applications unsuitable for the standard specifications described in the product catalog.

3. An application which could have negative effects on people, property, or animals requiring special safety analysis.

4. Use in an interlock circuit, which requires the provision of double interlock for possible failure by using a mechanical protective function, and periodical checks to confirm proper operation.



Safety Instructions

Caution

1. The product is provided for use in manufacturing industries.

The product herein described is basically provided for peaceful use in manufacturing industries. If considering using the product in other industries, consult SMC beforehand and exchange specifications or a contract if necessary. If anything is unclear, contact your nearest sales branch.

Limited warranty and Disclaimer/Compliance Requirements

The product used is subject to the following "Limited warranty and Disclaimer" and "Compliance Requirements".

Read and accept them before using the product.

Limited warranty and Disclaimer

1. The warranty period of the product is 1 year in service or 1.5 years after the product is delivered, whichever is first.*2)

Also, the product may have specified durability, running distance or replacement parts. Please consult your nearest sales branch.

2. For any failure or damage reported within the warranty period which is clearly our responsibility, a replacement product or necessary parts will be provided.

This limited warranty applies only to our product independently, and not to any other damage incurred due to the failure of the product.

3. Prior to using SMC products, please read and understand the warranty terms and disclaimers noted in the specified catalog for the particular products.

*2) Vacuum pads are excluded from this 1 year warranty.

A vacuum pad is a consumable part, so it is warranted for a year after it is delivered.

Also, even within the warranty period, the wear of a product due to the use of the vacuum pad or failure due to the deterioration of rubber material are not covered by the limited warranty.

Compliance Requirements

1. The use of SMC products with production equipment for the manufacture of weapons of mass destruction (WMD) or any other weapon is strictly prohibited.

2. The exports of SMC products or technology from one country to another are governed by the relevant security laws and regulation of the countries involved in the transaction. Prior to the shipment of a SMC product to another country, assure that all local rules governing that export are known and followed.

Caution

SMC products are not intended for use as instruments for legal metrology.

Products that SMC manufactures or sells are not measurement instruments that are qualified by pattern approval tests relating to the measurement laws of each country.

Therefore, SMC products cannot be used for business or certification ordained by the measurement laws of each country.

Operator

- ◆ This operation manual is intended for those who have knowledge of machinery using pneumatic equipment, and have sufficient knowledge of assembly, operation and maintenance of such equipment. Only those persons are allowed to perform assembly, operation and maintenance.
- ◆ Read and understand this operation manual carefully before assembling, operating or providing maintenance to the product.

■ Safety Instructions

Warning

- Do not disassemble, modify (including changing the printed circuit board) or repair.
An injury or failure can result.
- Do not operate the product outside of the specifications.
Do not use for flammable or harmful fluids.
Fire, malfunction, or damage to the product can result.
Verify the specifications before use.
- Do not operate in an atmosphere containing flammable or explosive gases.
Fire or an explosion can result.
This product is not designed to be explosion proof.
- Do not use the product in a place where static electricity is a problem.
Otherwise it can cause failure or malfunction of the system.
- If using the product in an interlocking circuit:
 - Provide a double interlocking system, for example a mechanical system
 - Check the product regularly for proper operationOtherwise malfunction can result, causing an accident.
- The following instructions must be followed during maintenance:
 - Turn off the power supply
 - Stop the air supply, exhaust the residual pressure and verify that the air is released before performing maintenanceOtherwise an injury can result.

Caution

- Do not touch the terminals and connectors while the power is on.
Otherwise electric shock, malfunction or damage to the product can result.
- After maintenance is complete, perform appropriate functional inspections and leak tests.
Stop operation if the equipment does not function properly or there is a leakage of fluid.
When leakage occurs from parts other than the piping, the product might be faulty.
Disconnect the power supply and stop the fluid supply.
Do not apply fluid under leaking conditions.
Safety cannot be assured in the case of unexpected malfunction.

■ NOTE

- Follow the instructions given below when designing, selecting and handling the product.
 - The instructions on design and selection (installation, wiring, environment, adjustment, operation, maintenance, etc.) described below must also be followed.
 - *Product specifications
 - The direct current power supply to combine should be UL approved as follows.
Circuit (of Class2) which is of maximum 30 Vrms (42.4 V peak) or less, with UL1310 Class2 power supply unit or UL1585 Class2 transformer.
 - The Pressure switch is a UL approved product only if it has a  mark on the body.
 - Use the specified voltage.
Otherwise failure or malfunction can result.
 - Do not exceed the specified maximum allowable load.
Otherwise it can cause damage or shorten the lifetime of the Pressure switch.
 - Design the product to prevent reverse current when the circuit is opened or the product is forced to operate for operational check.
Reverse current can cause malfunction or damage to the product.
 - Input data to the Pressure switch is not deleted, even if the power supply is cut off.
(Writing time: 1,000,000 times, Data duration: 10 years after power off)
 - Use the clean air
This can cause operating failure.
If compressed air containing condensate is used, install an air dryer or drain catch before the filter and perform drainage regularly.
If drainage is not performed regularly and condensate enters the secondary side, it can cause operating failure of pneumatic equipment.
If regular drainage is difficult, the use of a filter with an auto drain is recommended.
 - Applicable fluid is air, inert gases and incombustible gases.
Do not use a fluid containing chemicals, synthetic oils including organic solvent, salt and corrosive gases.
Otherwise, damage to the product and malfunction can result.
Check the details of the specifications before using.
 - Use the specified measurement flow rate and operating pressure.
Otherwise it can cause damage to the pressure switch or inability to measure correctly.
 - Reserve a space for maintenance.
Allow sufficient space for maintenance when designing the system.

●Product handling

*Installation

- Tighten to the specified tightening torque.
If the tightening torque is exceeded the mounting screws and brackets may be broken.
If the tightening torque is insufficient, the product can be displaced and loosen the mounting screws.
(Refer to "Mounting and Installation" on page 14.)
- Do not apply excessive stress to the product when it is mounted with a panel mount.
Otherwise damage to the product and disconnection from the panel mount can result.
- Be sure to ground terminal FG when using a commercially available switch-mode power supply.
- Do not drop, hit or apply shock to the Pressure switch.
Otherwise damage to the internal parts can result, causing malfunction.
- Do not pull the lead wire forcefully, not lift the product by pulling the lead wire. (Tensile force 35 N or less)
Hold the body when handling to avoid the damage of the Pressure switch which lead to cause the failure and malfunction.
- For piping of the Pressure switch, hold the piping with a spanner on the metal part of the piping (Piping attachment).
Holding other part with spanner leads to damage the Pressure switch.
- Eliminate any dust left in the piping by air blow before connecting the piping to the product.
Otherwise it can cause damage or malfunction.
- Do not apply excessive pressure to the piping port.
The product detects very small pressure. Do not apply pressure in excess of the proof pressure.
- Do not insert metal wires or other foreign matter into the pressure measurement port.
It can damage the pressure sensor causing failure or malfunction.
- Never mount a Pressure switch in a location that will be used as a foothold.
The product may be damaged if excessive force is applied by stepping or climbing onto it.
- If the entering of foreign material to the fluid is possible, install and pipe the filter or the mist separator to the inlet to avoid failure and malfunction.

*Wiring

- Do not pull the lead wires.
In particular, never lift a Pressure switch equipped with fitting and piping by holding the lead wires.
Otherwise damage to the internal parts can result, causing malfunction or to be off the connector.
- Avoid repeatedly bending or stretching the lead wire, or placing heavy load on them.
Repetitive bending stress or tensile stress can cause the sheath of the wire to peel off, or breakage of the wire.
If the lead wire can move, fix it near the body of the product.
The recommended bend radius of the lead wire is 6 times the outside diameter of the sheath, or 33 times the outside diameter of the insulation material, whichever is larger.
Replace the damaged lead wire with a new one.
- Wire correctly.
Incorrect wiring can break the Pressure switch.
- Do not perform wiring while the power is on.
Otherwise damage to the internal parts can result, causing malfunction.
- Do not route wires and cables together with power or high voltage cables.
Otherwise the product can malfunction due to interference of noise and surge voltage from power and high voltage cables to the signal line. Route the wires (piping) of the product separately from power or high voltage cables.
- Confirm proper insulation of wiring.
Poor insulation (interference from another circuit, poor insulation between terminals, etc.) can lead to excess voltage or current being applied to the product, causing damage.
- Design the system to prevent reverse current when the product is forced to operate for operational check.
Depending on the circuit used, insulation may not be maintained when operation is forced, allowing reverse current to flow, which can cause malfunction and damage the product.
- Keep wiring as short as possible to prevent interference from electromagnetic noise and surge voltage.
Do not use a cable longer than 30 m.
Wire the DC(-) line(blue) as close as possible to the power supply.
- When analogue output is used, install a noise filter (line noise filter, ferrite element, etc.) between the switch-mode power supply and this product.

*Environment

- Do not use the product in area that is exposed to corrosive gases, chemicals, sea water, water or steam.
Otherwise failure or malfunction can result.

- Do not use in a place where the product could be splashed by oil or chemicals.
If the product is to be used in an environment containing oils or chemicals such as coolant or cleaning solvent, even for a short time, it may be adversely affected (damage, malfunction, or hardening of the lead wires).
- Do not use in an area where surges are generated.
If there is equipment which generates a large amount of surge (solenoid type lifter, high frequency induction furnace, motor, etc.) close to the Pressure switch, this may cause deterioration or breakage of the internal circuit of the Pressure switch. Avoid sources of surge generation and crossed lines.
- Do not use a load which generates surge voltage.
When a surge-generating load such as a relay or solenoid is driven directly, use a Pressure switch with a built-in surge absorbing element.
- The product is CE marked, but not immune to lightning strikes. Take measures against lightning strikes in the system.
- Mount the product in a place that is not exposed to vibration or impact.
Otherwise failure or malfunction can result.
- Prevent foreign matter such as remnant of wires from entering the Pressure switch.
Take proper measures for the remnant not to enter the Pressure switch in order to prevent failure or malfunction.
- Do not use the product in an environment that is exposed to temperature cycle.
Heat cycles other than ordinary changes in temperature can adversely affect the inside of the product.
- Do not expose the product to direct sunlight.
If using in a location directly exposed to sunlight, shade the product from the sunlight.
Otherwise failure or malfunction can result.
- Keep within the specified fluid and ambient temperatures range.
The fluid and ambient temperatures should be 0 to 50 °C. Operation under low temperature (5 °C or less) leads to cause damage or operation failure due to frozen moist in the fluid or air.
Protection against freezing is necessary. Air dryer is recommended for elimination of drain and water.
Avoid sudden temperature change even within specified temperature.
- Do not operate close to a heat source, or in a location exposed to radiant heat.
Otherwise malfunction can result.

*Adjustment and Operation

- Turn the power on after connecting a load.
Otherwise it can cause excess current causing instantaneous breakage of the Pressure switch.
- Do not short-circuit the load.
Although error is displayed when the Pressure switch load is short circuit, generated excess current lead to cause the damage of the Pressure switch.
- Do not press the setting buttons with a sharp pointed object.
It may damage the setting buttons.
- If using the product to detect very small pressure rates, warm up the product for 10 to 15 minutes first.
There will be a drift on the display and the analogue output of approximate $\pm 1\%$ immediately after the power supply is turned on, within 10 minutes.
- Perform settings suitable for the operating conditions.
Incorrect setting can cause operation failure.
For details of each setting, refer to page 19 to 48 of this manual.
- Do not touch the LCD during operation.
The display can vary due to static electricity.

*Maintenance

- Turn off the power supply, stop the supplied air, exhaust the residual pressure and verify the release of air before performing maintenance.
There is a risk of unexpected malfunction.
- Perform regular maintenance and inspections.
There is a risk of unexpected malfunction.
- Perform drainage regularly.
If condensate enters the secondary side, it can cause operating failure of pneumatic equipment.
- Do not use solvents such as benzene, thinner etc. to clean the Pressure switch.
They could damage the surface of the body and erase the markings on the body.
Use a soft cloth to remove stains. For heavy stains, use a cloth soaked with diluted neutral detergent and fully squeezed, then wipe up the stains again with a dry cloth.

Model Indication and How to order

ZSE30AF - **01** - **N** - - X576~X580

Piping specification

Symbol	Content
01	R1/8 (with M5 female thread)
N01	NPT1/8 (with M5 female thread)

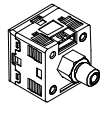

Output specification

Symbol	Content
N	NPN open collector 1 output
P	PNP open collector 1 output
A	NPN open collector 2 outputs
B	PNP open collector 2 outputs
C	NPN open collector 1 output + Analogue voltage output
D	NPN open collector 1 output + Analogue current output
E	PNP open collector 1 output + Analogue voltage output
F	PNP open collector 1 output + Analogue current output

Unit specification

Symbol	Content
Nil	With unit conversion function *1
M	Fixed SI unit *2

*1: The new Measurement Law prohibits the use of pressure switch with the unit conversion function in Japan. A unit label is attached.

*2: Fixed unit kPa, Pa

Option 1

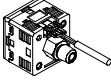
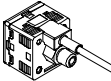
Symbol	Content
Nil	Without lead wire 
L	With connector attached lead wire (lead wire length 2 m) *4 
G	With connector attached lead wire (lead wire length 2 m) and connector cover *4 

*4: The output specification "N" or "P" is equipped with 3 cores lead wire, and 4 cores lead wire for others.

Table 1: Refer to the table below for the Made to order.

Option 3

Symbol	Operation manual Booklet *3	Calibration certificate
Nil	○	-
Y	-	-
K	○	○
T	-	○

*3: An operation manual booklet for the standard product is included with the product.

Option 2



Symbol	Content
Nil	Option 2
A1	Bracket A 
A2	Bracket B 
A3	Bracket C 
B	Panel mount adapter 
D	Panel mount adapter + Front protective cover 

Table1. Made to order

Symbol	Specification (Rated pressure range)
X576	±500 Pa
X577	±1 kPa
X578	±2 kPa
X579	±5 kPa
X580	±10 kPa

○Accessories / Part numbers

If an accessory is required independently, order with the following part number.

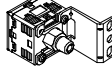
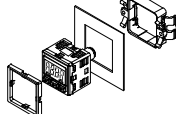
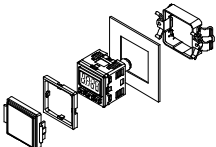
Description	Part number	Remarks
Bracket A	ZS-38-A1	Mounting screw (M3 x 5L, 2 pcs.)
Bracket B	ZS-38-A2	Mounting screw (M3 x 5L, 2 pcs.)
Bracket C	ZS-38-A3	Mounting screw (M3 x 5L, 2 pcs.)
Panel mount adapter	ZS-27-C	Mounting screw (M3 x 8L, 2 pcs.)
Panel mount adapter + Front protective cover	ZS-27-D	Mounting screw (M3 x 8L, 2 pcs.)
Lead wire with connector	ZS-38-3L	3 cores for 1 output, 2 m
Lead wire with connector	ZS-38-4L	4 cores for 2 outputs, 2 m
Lead wire with connector + connector cover	ZS-38-3G	3 cores for 1 output, 2 m
Lead wire with connector + connector cover	ZS-38-4G	4 cores for 2 outputs, 2 m
Lead wire with connector for copy function	ZS-38-5L	3 cores (for copy function), 1 m
Lead wire with connector unit for copy function	ZS-38-U	for copy function (10 slaves max.)
Front protective cover	ZS-27-01	-

Summary of Product parts

Names of individual parts

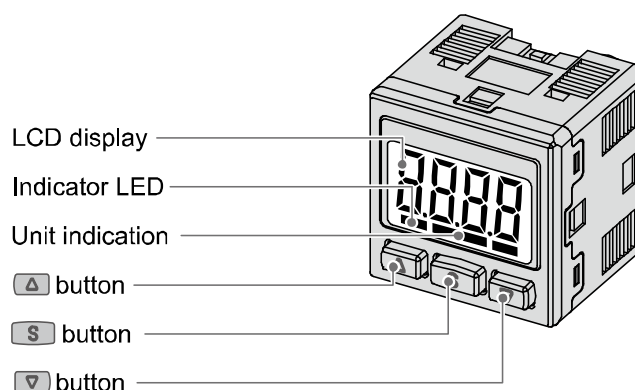

Indicator LED (Green OUT1 and Red OUT2): Displays the switch output condition.

LCD display: Displays the current status of pressure, setting mode, selected indication unit and error code.
Four display modes can be selected: display always in red or green, or display changing from green to red, or red to green, according to the output status.

▲ button: Selects the mode or increases the ON/OFF set value.
Press this button to change to the peak display mode.

▼ button: Selects the mode or decreases the ON/OFF set value.
Press this button to change to the bottom display mode.

S button: Press this button to change to another mode and to set a value.

Unit indication: Displays the unit currently selected. (only for kPa unit indication).

■ Definition and terminology

	Terms	Meaning
2	2-colour display	2 colours are used to indicate a value, which change according to the output status.
7	7-segment display	When "8" is shown on the display. It is called 7-segment because 8 consists of 7 pieces of "-" (segments)".
A	Analogue current output	Refer to "Analogue output (function)".
	Analogue output function	A function to output the voltage or current in proportion to the pressure.
	Analogue voltage output	Refer to "Analogue output (function)".
	Auto preset	A function to automatically set up the pressure by having equipment hold and release a workpiece via vacuum adsorption. This function is used in an application where vacuum adsorption of a workpiece is confirmed by a Pressure switch.
B	Bottom value display	Displays the minimum pressure reached up to that moment.
C	Chattering	The problem of the switch output turning ON and OFF repeatedly around the set value at high frequency due to the effect of pulsation.
	Chattering prevention function	A function to delay the response time of switch output in order to prevent chattering.
	Copy function	A function to copy a pressure setting value and function setting (excluding fine adjustment of display value).
D	Delay time	The setting time from when the pressure applied to the pressure switch reaches the set value, to when the ON-OFF output actually begins working. Delay time setting can prevent the output from chattering.
	Digit (Minimum setting unit)	Shows how precisely the pressure can be displayed or set by the digital Pressure switch. When 1 digit = 1 kPa, the pressure is given with an increment of 1kPa, e.g., 1, 2, 3, ..., 99, 100.
	Digital filter	Function to add digital filtering to the fluctuation of pressure value. Smooth the fluctuation of displayed value and analogue output for sharp start up or fall of the pressure. When the function is valid, digital filtering is reflected to the ON/OFF of the switch output. Output chattering or flicker in the measurement mode display can be reduced by setting the digital filter. The response time indicates when the set value is 90% in relation to the step input.
	Display accuracy	The deviation between displayed pressure value and the true pressure.
	Display colour	The colour of the digital display. There are four choices: normally green, normally red, green (off) to red (on), and red (off) to green (on).
	Display resolution	How fine the rated pressure range can be displayed.
	Display unit	The unit of pressure used on the display.
	E	Error indication
F	Fine adjustment mode	Refer to "Fine adjustment of display value".
	Fine adjustment of display value	A displayed pressure value can be adjusted within the range of $\pm 5\%$ R.D. ($\pm 5\%$ of the displayed value). It is used if a true pressure value is known or to correct the difference of a displayed value of the measurement equipment nearby which measures the same pressure.
	F.S. (full span/full scale)	Abbreviation for full span or full scale; this means the maximum fluctuation range of the Pressure switch rated value. For example, when the output voltage is 1 to 5[V], the F.S. will be $5-1=4$ [V]. (Ref: $1\%F.S.=4 \times 0.01=0.04$ [V])
	Function selection mode	This is a mode in which each function is set up, and is a separate menu from the pressure setup. If the setting needs to be changed, "F*", each item can be set up. The items to be set up are: display colour, operation mode, output type, response time, display resolution, fine adjustment of display value, auto preset, power-saving mode, security code number and low-cut function.

	Terms	Meaning
H	Hysteresis	The difference between the pressure switch ON and OFF points, used to prevent chattering.
	Hysteresis mode	Refer to "List of output modes" on page 27.
I	Indicator LED	The LED that turns on when the switch output is on.
	Insulation resistance	Insulation resistance of the product itself. The resistance between an electrical circuit and the pressure switch body.
K	Key lock (function)	A function that locks the setting buttons so that no accidental setting changes can be made.
L	Load impedance	Refer to "Max. load impedance".
	Low-cut function	Function to prevent display flicker at atmospheric pressure. 0 is displayed for pressure when the pressure is near atmospheric pressure.
M	Manual set up	Manual pressure set up without using auto preset. This term is used to distinguish from the pressure set up using auto preset.
	Master Pressure switch	A Pressure switch whose settings are copied when using the copy function.
	Max. applied voltage	The maximum value of applied voltage available to the output wire of the NPN output.
	Max. load current	The maximum current available to the output wire of the switch output.
	Max. (Min.) load impedance	The maximum (minimum) load (resistance value and impedance) which can be connected to the output (output wire) of the analogue current output.
	Measurement mode	The condition in which the pressure is detected and displayed and the switch output is operating.
	Min. setting unit	Refer to "digit".
N	Normal output	The switch output operation in which the switch is turned on when pressure equal to or greater than the set value is detected. In the (hysteresis mode) window comparator mode, it is the operation in which the switch is turned on when pressure is within the switch output range (P1L to P1H or P2L to P2H). (Refer to "List of output modes" on page 27.)
	NPN (open collector) output	The switch output which uses the NPN transistor for output.
O	Operating mode	There are two choices, hysteresis mode and window comparator mode.
	Output impedance	The resistance value of a component between the voltage output element and the analogue voltage output. It is indicated as a resistance value which is converted in accordance with the condition in which resistance is directly connected to the voltage output element. There may be an error in the output voltage depending on this output impedance and the input impedance of customers' equipment. (example: If the Pressure switch with output impedance of 1 kΩ is connected to the A/D converter to detect the analogue output of 5 V, the detected voltage by the A/D converter becomes $5(V) \times 1(M\Omega)/(1(k\Omega) + 1(M\Omega)) \approx 4.995(V)$, and there is an error of approximate 0.005 V).
	Output type	The operation type of the switch output. Either normal output or reversed output can be selected. (Refer to "List of output modes" on page 27.)

	Terms	Meaning
P	Peak value display	Displays the maximum pressure reached up to that moment.
	Piping-port size	The size of the port on the switch body with which a device can be connected.
	PNP (open collector) output	The switch output that uses the PNP transistor for output.
	Power saving mode	The condition in which the display is turned off to reduce current consumption.
	Pressure-sensing part	The pressure-detecting part of a pressure-detecting element.
	Pressure setting	The setting of pressure to determine the point at which the Pressure switch turns on and off.
	Proof pressure	The pressure beyond which the Pressure switch will be damaged.
R	Rated pressure range	The pressure range in which the Pressure switch meets the specifications. Values outside of this range can be set if they are within the set pressure range, but cannot be guaranteed to meet the product specifications.
	R.D.	The value currently displayed. For example, when the displayed value is 1.000, $\pm 5\%$ R.D. will be ± 0.05 , which is $\pm 5\%$ of 1.000, while for a displayed value of 0.800 it will be 0.04.
	Repeatability	Reproducibility of the displayed value for pressure and ON-OFF output operating point when the pressure changes.
	Residual voltage	The difference between the ideal ON voltage and the actual voltage when the switch output is on. It depends on the load current and ideally should be "0".
	Resolution	Refer to "Indication resolution".
	Reversed output	The switch output operation in which the switch is turned on when pressure equal to or less than the set value is detected. In the (hysteresis mode) window comparator mode, it indicates the operation in which a switch is turned on when pressure is outside the switch output range (n1L to n1H or n2L to n2H). (Refer to "List of output modes" on page 27.)
	Ripple	A type of chattering.
S	Setting of function	Refer to "Function selection mode".
	Setting pressure range	The pressure range within which the switch output can be set.
	Slave Pressure switch	A Pressure switch whose settings are copied to when using the copy function.
	Switch output	Alternatively called "ON-OFF output".
U	Units selection function	Function to change the unit in which the value of pressure is displayed. Only a product with this function can change the unit. A product with Units selection function cannot be purchased if it is used within Japan. Pressure is indicated only by SI units in Japan.
W	Wetted part (or part exposed to fluid)	The part of the Pressure switch which is in contact with the detected fluid, such as a pressure sensor, seal, or fitting.
	Window comparator mode	An output type which holds the output when the pressure is within a certain range. (Refer to "List of output modes" on page 27.)
	Withstand voltage	The ability to withstand a voltage applied between an electrical circuit and the body. If more voltage is applied to the product, the product may be damaged. (voltage mentioned here is not power voltage to activate the product).
Z	Zero clear function	The function which can adjust the displayed pressure value to "0".

Mounting and Installation

■ Installation

○ Mounting with bracket

*: The required tightening torque of the piping port is 7 to 9 Nm.

The required tightening torque of the mounting bracket screws is 0.5 to 0.7 Nm.

● Fix the bracket to the Pressure switch with the set screws M3×5L (2 pcs) supplied.

● Bracket A (Model: ZS-38-A1)

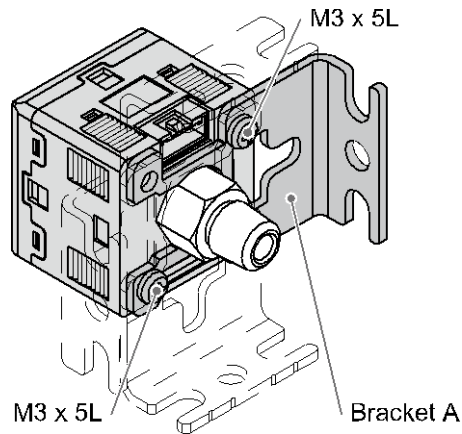

● Bracket B (Model: ZS-38-A2)

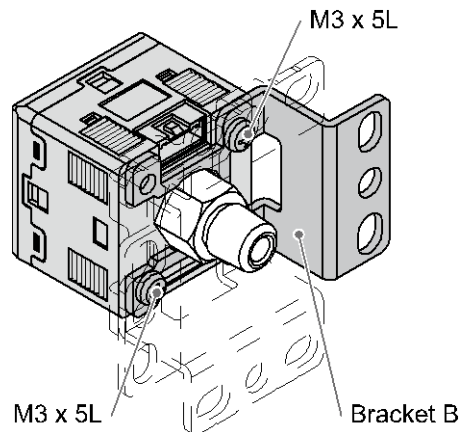

● Bracket C (Model: ZS-38-A3)

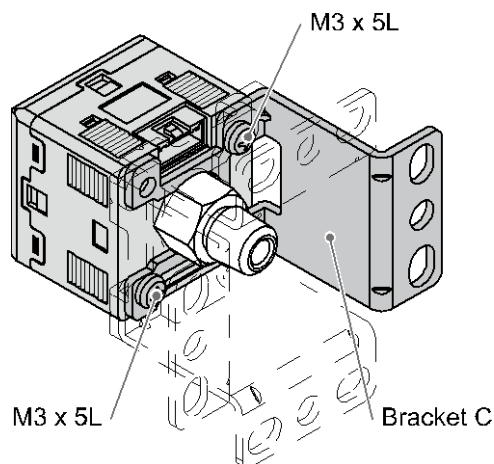

*: The bracket A/B/C can be mounted in 4 ways.

○ Mounting with panel mount adapter

- Fix the panel mount adapter to the Pressure switch with the set screws M3x8L (2 pcs.) supplied.
- Panel mount adapter (Model: ZS-27-C)
- Panel mount adapter + Front protective cover (Model: ZS-27-D)

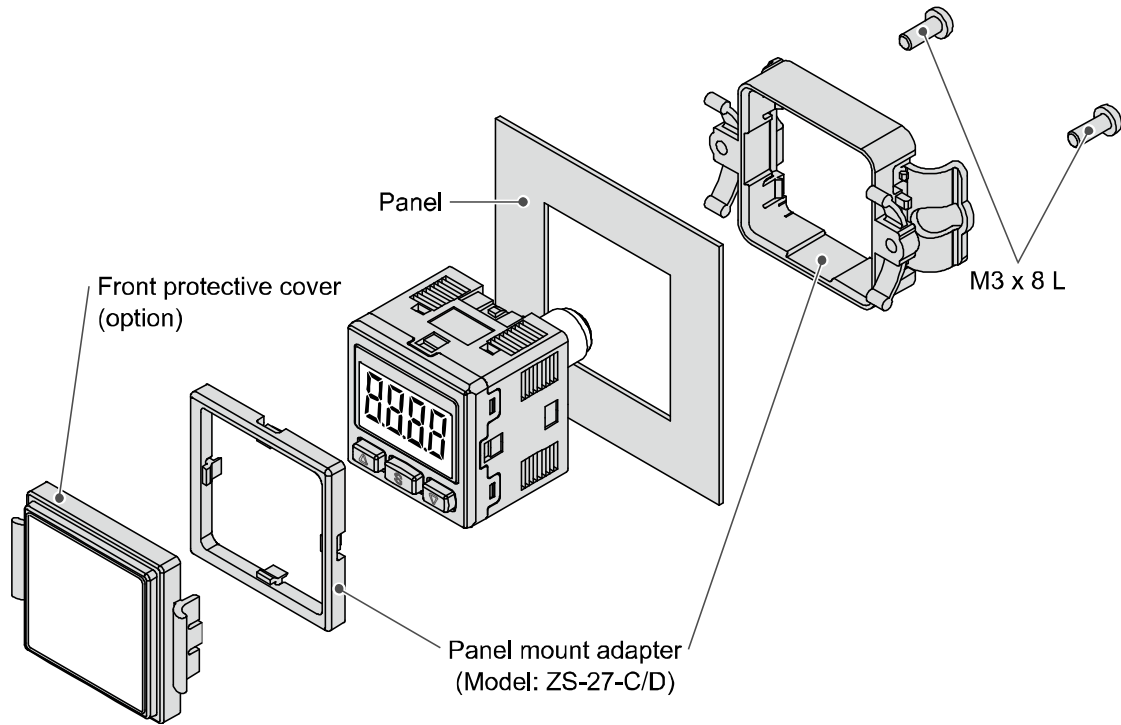

*: The panel mount adapter can be rotated by 90 degrees for mounting.

Note when removing the switch

- The Pressure switch with panel mount adapter can be removed from the installation by removing 2 screws and releasing the hooks at the sides, as illustrated. Take care not to damage the Pressure switch and panel mount adapter.

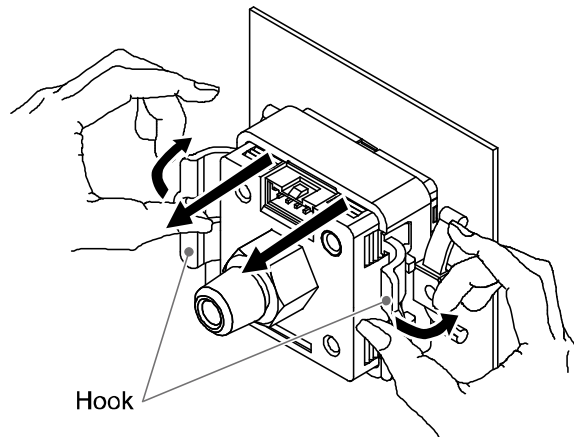

■Wiring

○Connection

- Connections should only be made with the power supply turned off.
- Use a separate route for the Pressure switch wiring and any power or high voltage wiring. Otherwise, malfunction may result due to noise.
- Ensure that the FG terminal is connected to ground when using a commercially available switch-mode power supply. When a switch-mode power supply is connected to the product, switching noise will be superimposed and the product specification can no longer be met. This can be prevented by inserting a noise filter, such as a line noise filter and ferrite core, between the switch-mode power supply and the product, or by using a series power supply instead of a switch-mode power supply.

○Connector

Connecting/Disconnecting

- When mounting the connector, insert it straight into the socket, holding the lever and connector body, and push the connector until the lever hooks into the housing, and locks.
- When removing the connector, press down the lever to release the hook from the housing and pull the connector straight out.

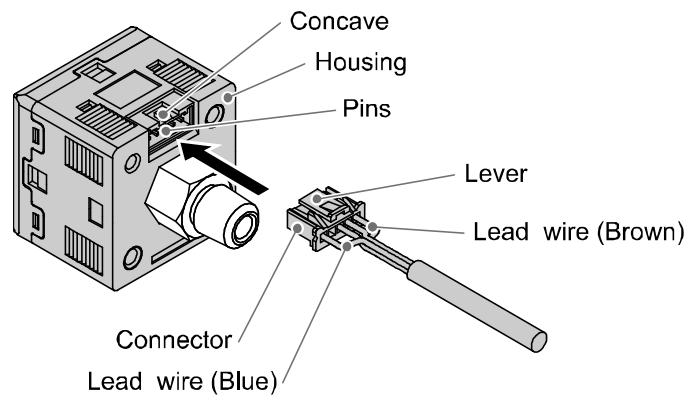

Connector pin numbers

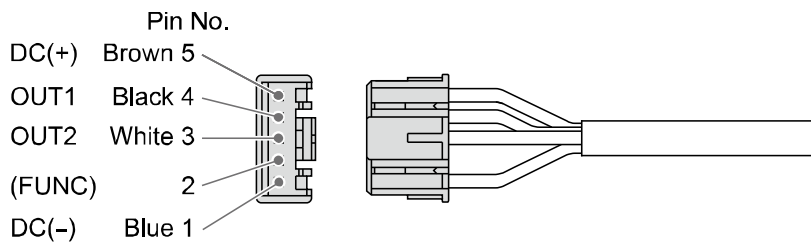

Internal circuit and wiring example

Z/ISE30A(F)-□-□-□□□□-X576~X580

• Output specification

-N

NPN open collector 1 output
Max. 28 V, 80 mA
Residual voltage 1 V or less

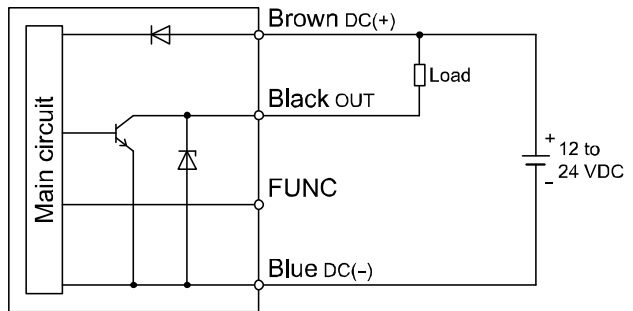

-P

PNP open collector 1 output
Max. 80 mA
Residual voltage 1 V or less

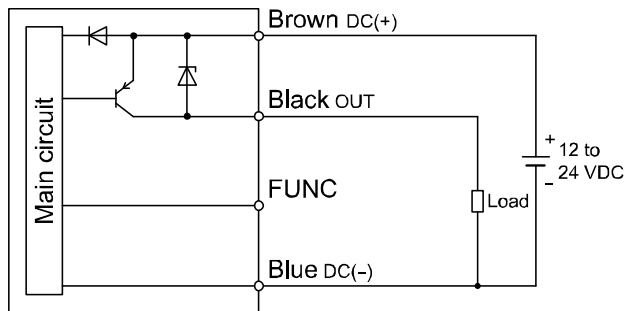

-A

NPN open collector 2 outputs
Max. 28 V, 80 mA
Residual voltage 1 V or less

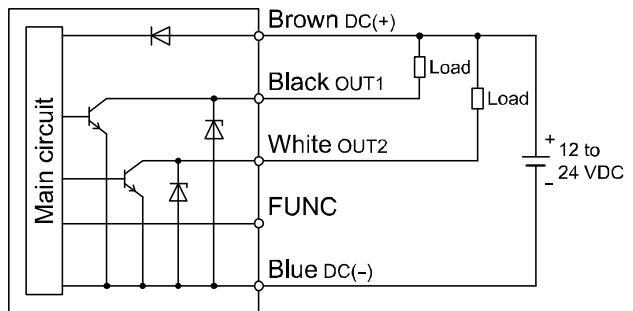

-B

PNP open collector 2 outputs
Max. 80 mA
Residual voltage 1 V or less

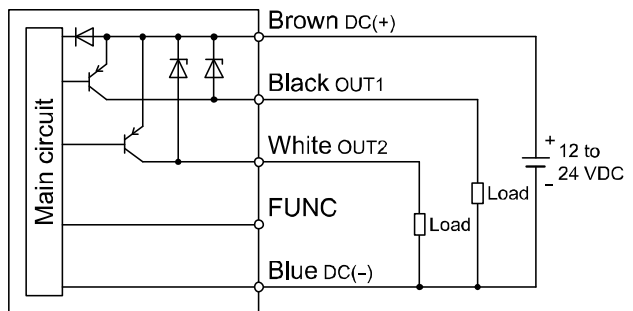

-C

NPN open collector 1 output
Max. 28 V, 80 mA
Residual voltage 1 V or less
Analogue voltage output
Output impedance approx. 1 k Ω

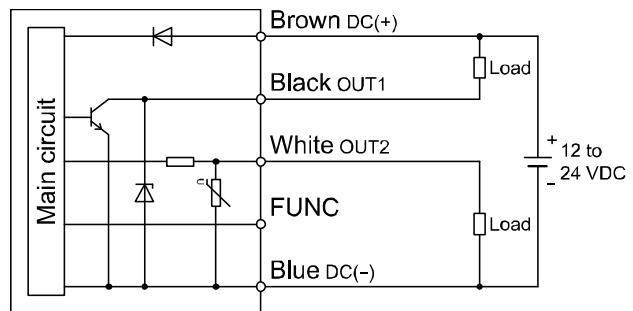

-D

NPN open collector 1 output
Max. 28 V, 80 mA
Residual voltage 1 V or less
Analogue current output
Max. load impedance
300 Ω at 12 V power supply voltage
600 Ω at 24 V power supply voltage
Min. load impedance 50 Ω

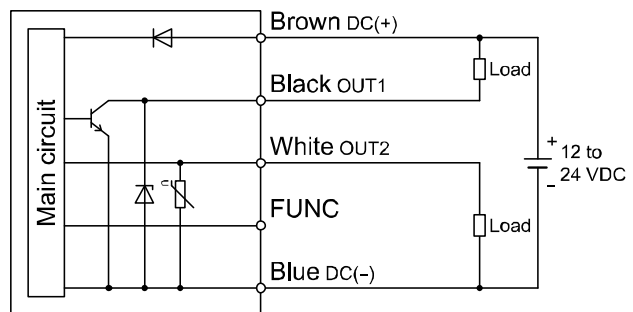

-E

PNP open collector 1 output
Max. 80 mA
Residual voltage 1 V or less
Analogue voltage output
Output impedance approx. 1 k Ω

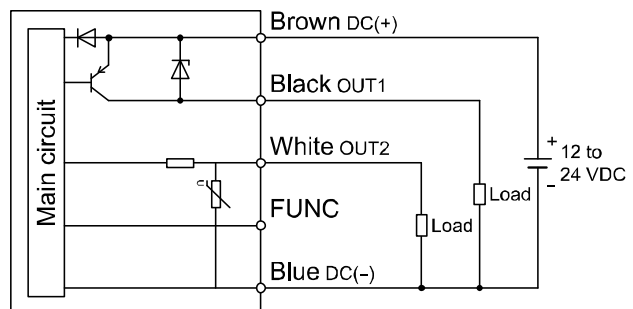

-F

PNP open collector 1 output
Max. 80 mA
Residual voltage 1 V or less
Analogue current output
Max. load impedance
300 Ω at 12 V power supply voltage
600 Ω at 24 V power supply voltage
Min. load impedance 50 Ω

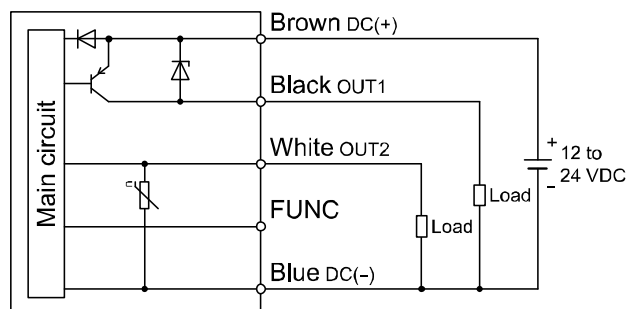

Pressure Setting

■ Measurement mode

The measurement mode is the condition where the pressure is detected and displayed, and the switch function is operating.

This is the basic mode, and other modes should be selected for setting changes and other function settings.

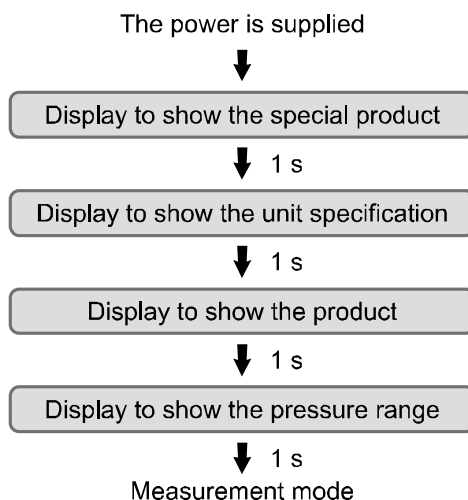

Setting the ON and OFF points of the Pressure switch.

Operation

When the pressure exceeds a set point, the Pressure switch will be turned ON.

When the pressure falls below the set point by the amount of hysteresis or more, the Pressure switch will be turned OFF.

The default setting of the output set value is the central value between the atmospheric pressure and the upper limit of the rated pressure range.

If this condition, shown below, is acceptable, then keep these settings.

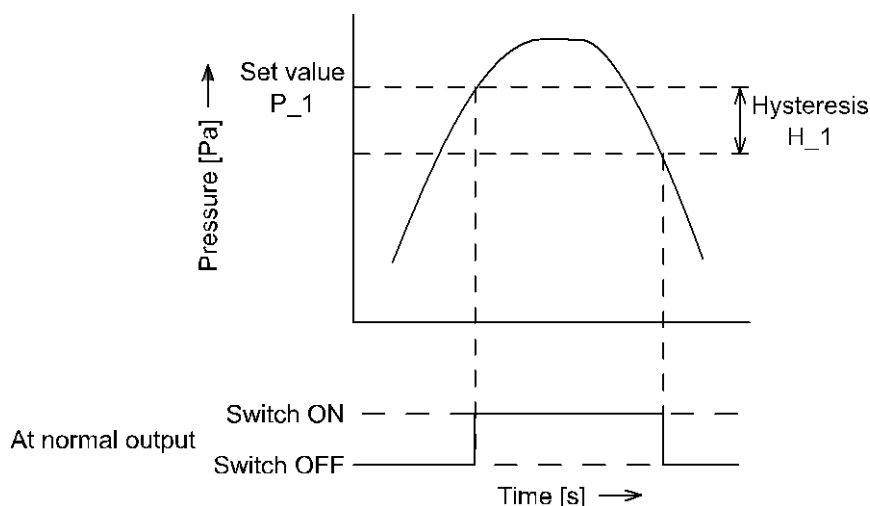

<Operation>

[Hysteresis mode]

- 1, Press the **S** button once in measurement mode.



- 2, [P_1] or [n_1] and the set value are displayed in turn.

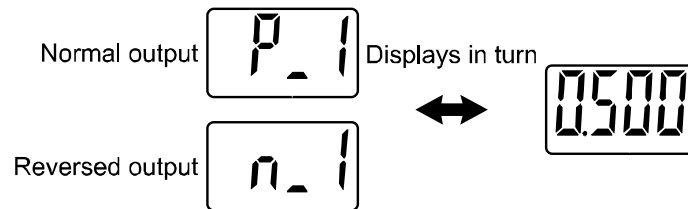

- 3, Press the **Δ** or **▽** button to change the set value.
The **Δ** button is to increase and the **▽** button is to decrease.

- Press the **Δ** button once to increase by one digit, and press it continuously to keep increasing the set value.

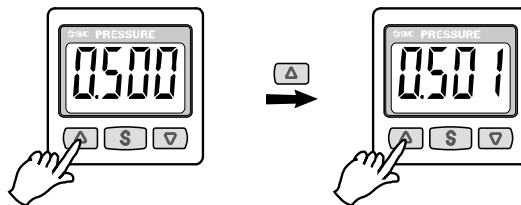

- Press the **▽** button once to decrease by one digit, and press it continuously to keep decreasing the set value.

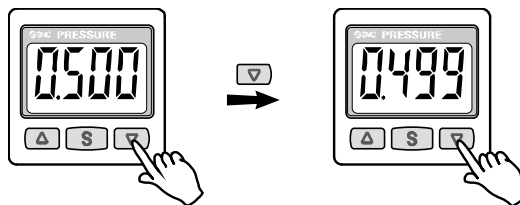

4, Press the **S** button to finish the setting.

For models with 2 outputs, [P_2] or [n_2] will be displayed. Set as above.

The Pressure switch operates within a set pressure range (from P1L to P1H) during window comparator mode. Set P1L (switch lower limit) and P1H (switch upper limit) with the setting procedure above. (When reversed output is selected, [n1L] and [n1H] are displayed.)

Zero clear of Display

The display is reset to zero when the **Δ** and **▽** buttons are pressed simultaneously for 1 second. For the first operation, always perform zero clear with no pressure applied.

Function Setting

■Function selection mode

In measurement mode, press the **[S]** button for 2 seconds or longer to display [F 0]. Select to display the function to be changed, [F□□].

Press the **[S]** button for 2 seconds or longer in function selection mode to return to measurement mode.

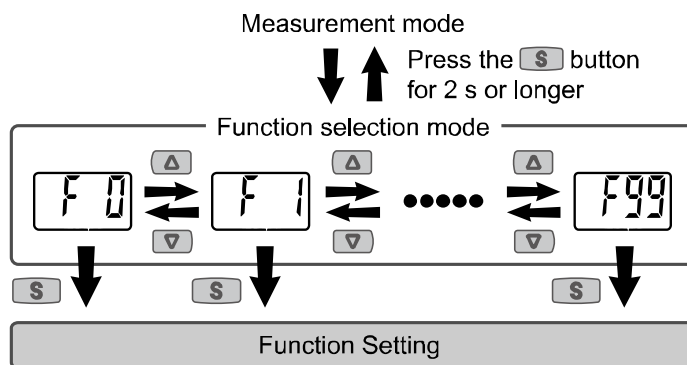

*: Some functions are not available depending on part number. All functions are displayed with [F□□] followed by the function description. If a function is not available, the function is displayed as [--].

■Default setting

At the time of shipment, the following settings are provided.

If this condition is acceptable, then keep these settings.

To change the settings, enter function selection mode.

- [F 0] Units selection function ➡ Page 24

Part number	Default setting
X576	Pa
X577	kPa
X578	
X579	
X580	

•[F 1] Setting of OUT1 ➡ Page 25

Item	Description	Default setting
Output mode	Select hysteresis mode or window comparator mode.	Hysteresis mode
Reversed output	Select reversed output.	Normal output
Pressure setting	Set the ON or OFF point of the switch output	X576: 250 Pa X577: 0.500 kPa X578: 1.00 kPa X579: 2.50 kPa X580: 5.00 kPa
Hysteresis	Set the hysteresis to prevent chattering.	X576: 25 Pa X577: 0.050 kPa X578: 0.10 kPa X579: 0.25 kPa X580: 0.50 kPa
Display colour	Select the display colour.	ON: Green OFF: Red

•[F 2] Setting of OUT2 ➡ Page 28

Same setting as for [F 1] OUT1.

The display colour is linked to the setting of OUT1, and can not be set for OUT2.

•Other parameter settings

Item	Page	Default setting
[F 3] Response time	page 29	Digital filter: 1 s Delay time: 4 ms
[F 4] Display resolution	page 32	Depends on the specification of the special product
[F 5] Auto-preset function	page 33	Manual
[F 6] Fine adjustment of display value	page 35	0%
[F 7] Power saving mode	page 36	OFF
[F 8] Security code	page 37	OFF
[F 9] Setting of low-cut function	Page 38	OFF
[F90] Setting of all functions	page 39	OFF
[F97] Copy function	page 41	OFF
[F98] Check of output	page 43	Normal
[F99] Reset to the default setting	page 45	OFF

■[F 0] Units selection function

Only the product with Units selection function can be set.

The displayed unit can be changed, and depends on the pressure range.

(Pa/kPa units are available when the product does not have the units selection function).

<Operation>

Press the or button in function selection mode to display [F 0].

Press the button. Move on to select the display unit.

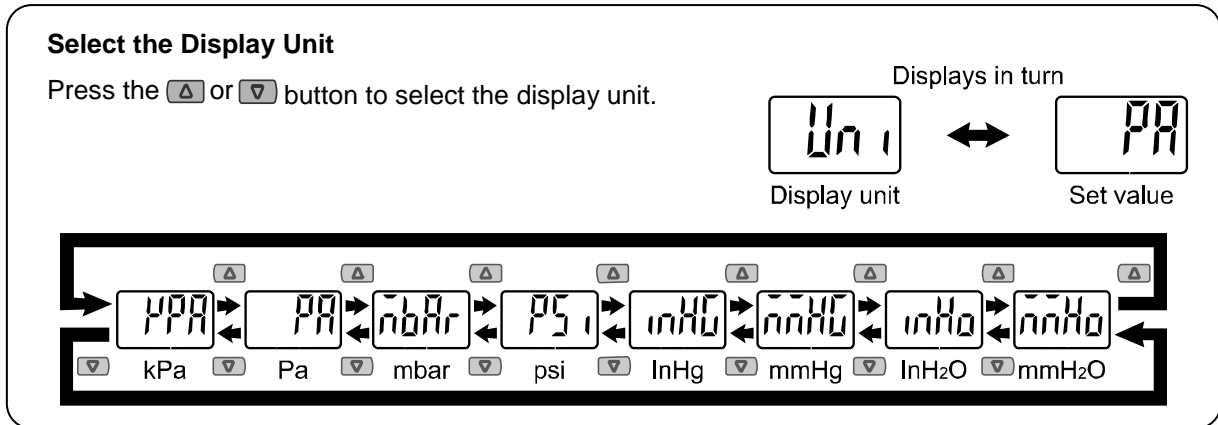

Setting of [F 0] Units selection function completed

•Display unit and minimum setting unit

Part Number	Rated value	kPa	Pa	mbar	psi	inHg	mmHg	inH ₂ O	mmH ₂ O
X576	±500 Pa	0.001	1 (Initial operation)	0.01	0.001	0.001	0.01	0.01	0.1
X577	±1 kPa	0.001 (Initial operation)	1	0.01	0.001	0.001	0.01	0.01	0.1
X578	±2 kPa	0.01 (Initial operation)	2	0.1	0.001	0.001	0.1	0.01	1
X579	±5 kPa	0.01 (Initial operation)	-	0.1	0.001	0.01	0.1	0.1	1
X580	±10 kPa	0.01 (Initial operation)	-	0.1	0.01	0.01	0.1	0.1	1

-: No unit for display

■[F 1] Setting of OUT1

Set output method of OUT1.

The output turns on when the pressure exceeds the set value. The default setting of the output set value is the central value between the atmospheric pressure and the upper limit of the rated pressure range.

The display colour depends on the condition of OUT1.

The default setting of the display colour is as follows: green display when the output is ON and red display when the output is OFF.

For the operation of each setting, refer to "List of output modes" on page 27.

<Operation>

Press the or button in function selection mode to display [F 1].

Press the button. Move on to setting of output mode.

Select output mode

Press the or button to select output mode.

Hysteresis

Window comparator

Output mode

Set value

Displays in turn

Press the button to set. Move on to setting of reversed output.

Select reversed output

Press the or button to select reversed output.

Normal output

Reversed output

Reversed output

Set value

Displays in turn

Press the button to set. Move on to setting of pressure.

Pressure Setting

Set the pressure based on the setting procedure on page 20.



"P" becomes "n" when reversed output is selected. ([P_1] → [n_1])

Hysteresis mode: [P_1]

Window comparator mode: [P1L] [P1H]

Press the button to set. Move on to setting of hysteresis.

Setting of Hysteresis

Press the  or  button to select hysteresis.

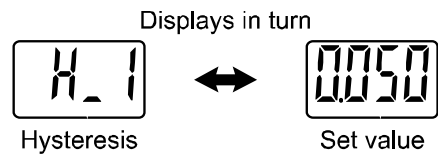

Press the  button to set. ↓ Move on to setting of display colour.

Selection of display colour

Press the  or  button to select display colour.

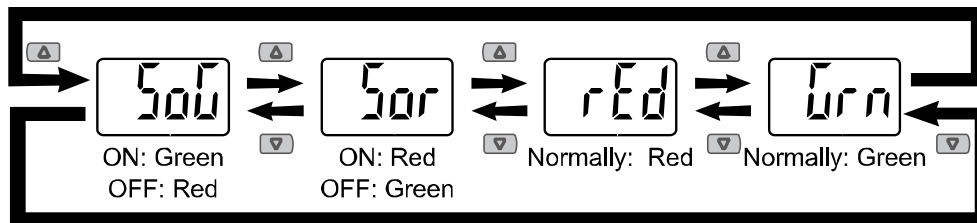
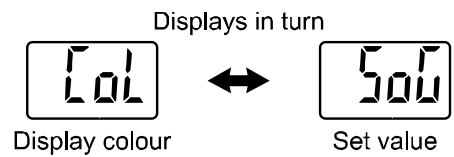

Press the  button to set. ↓ Return to function selection mode.

Setting of [F 1] operation of OUT1 completed

*1: The selected parameter becomes effective after pressing the  button.

*2: After setting, it is possible to move to measurement mode by pressing the  button for 2 seconds or longer.

•List of output modes

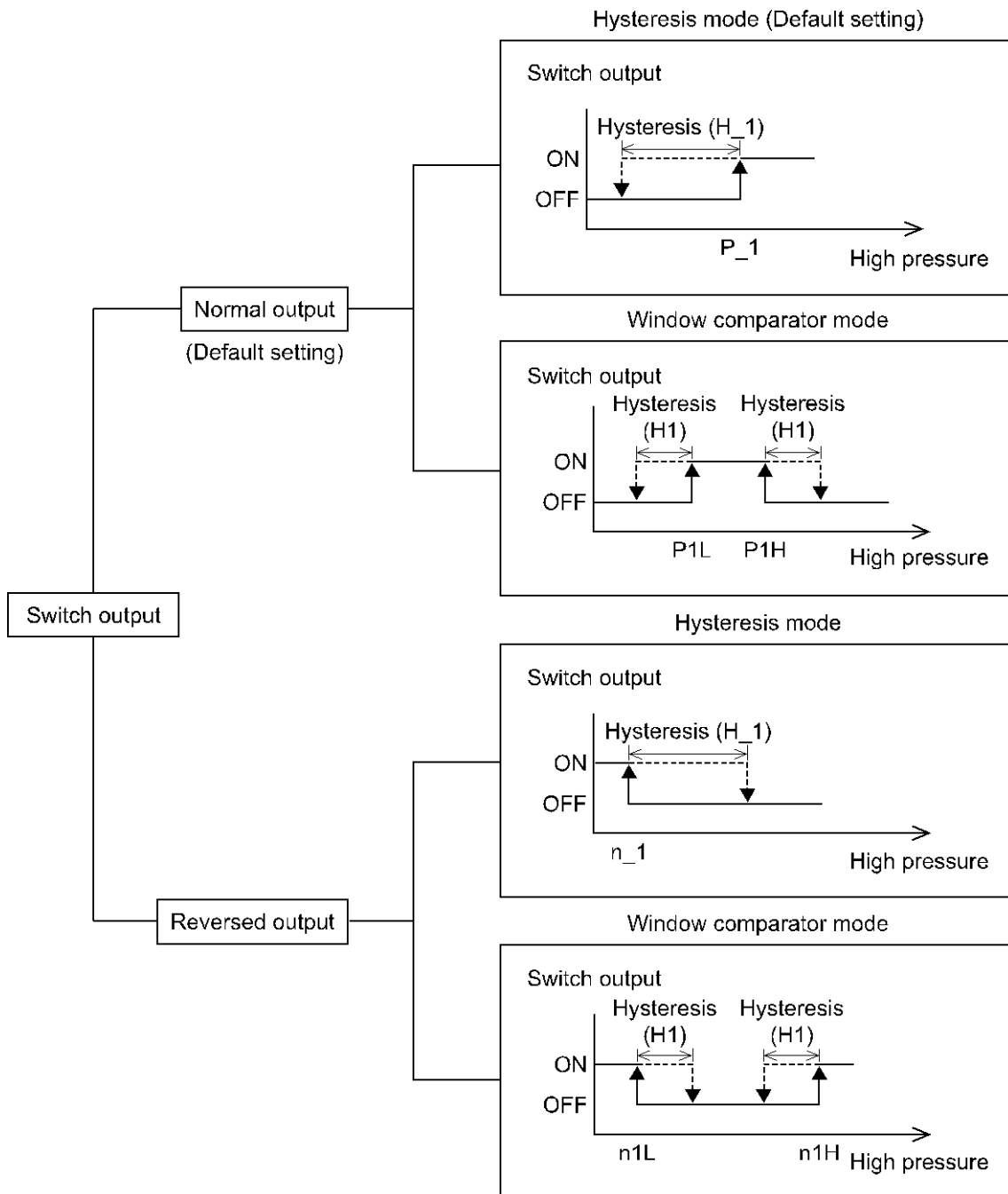

If the set point when the switch output is changed is outside the set pressure range due to switching between normal and reversed output, the hysteresis will automatically be compensated.

*: The above figure shows the operation of OUT1.



For the operation of OUT2, "1" shown in the figure above becomes "2". (Ex) $P_1 \rightarrow P_2$

■[F 2] Setting of OUT2

Set output method of OUT2.

The display colour is linked to the setting of OUT1, and can not be set for OUT2

<Operation>

Press the  or  button in function selection mode to display [F 2].

Press the  button  Moves on to setting of output mode

Set [F 2] based on [F 1] setting of OUT1 (page [25](#) to [27](#))

*: If there is only 1 output or the analogue output is used, the display indicates [--], and this function cannot be set.

■[F 3] Response time

There are 2 types of setting for the response time. (1) Digital filter and (2) Delay time.

(1) Digital filter setting ("FiL")

- Filter time constant can be set (90% response).
- The Digital filter can be set in 2 modes. Rough adjustment mode (0, 0.2, 0.5, 1, 2, 5, 10, and 20s) and fine adjustment mode (200 to 1000 ms, incremented by 5 ms).
- Fluctuation of pressure display and analogue output can be reduced by increasing the set value of the digital filter. The chattering of the switch output can also be reduced. (Effective when the pressure fluctuation is large).

*: The digital filter set value affects the response of the pressure display, analogue output and switch output. (refer to the figure below.)

(2) Delay time setting ("dt")

- Delay time of the switch output can be set.
- The chattering of the switch output can also be reduced by increasing the delay time.

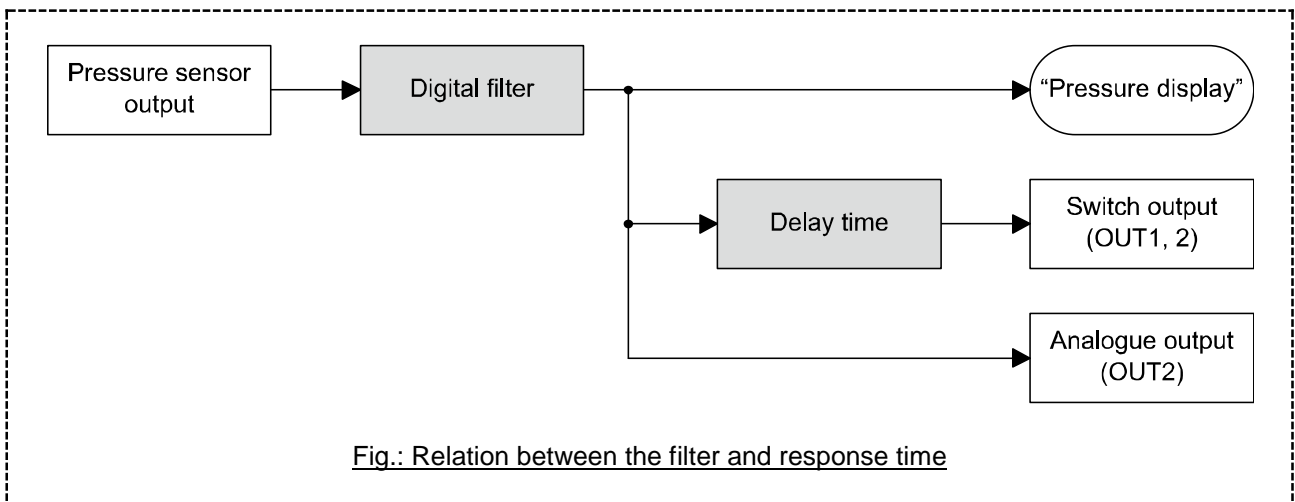

<Operation>

Press the or button in function selection mode to display [F 3].

Press the button. ↓ Move on to the setting of the filter time constant.

(1) Digital filter setting ("FiL")

Press the or button to select the desired output mode.

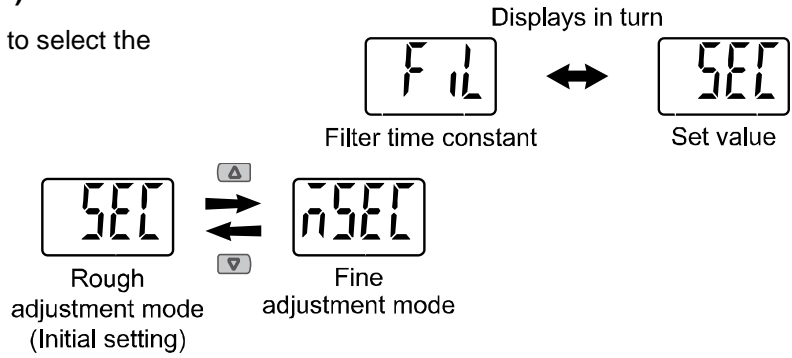

Rough adjustment mode

Press the button to set.

Rough adjustment mode setting

Press the or button to set the filter time constant (90% response).

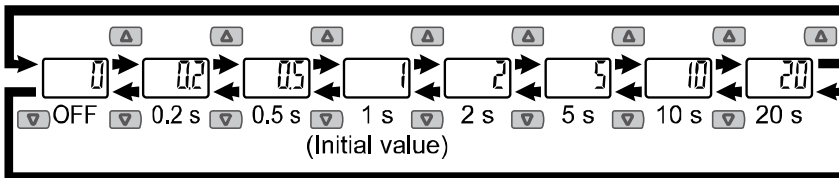
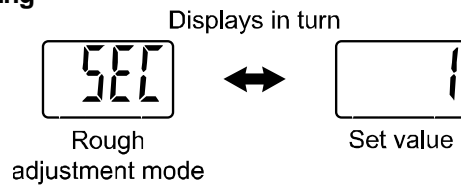

Press the button to set.

Fine adjustment mode

Press the button to set.

Fine adjustment mode setting

Press the or button to set the filter time constant (90% response) with increments of 5 ms.

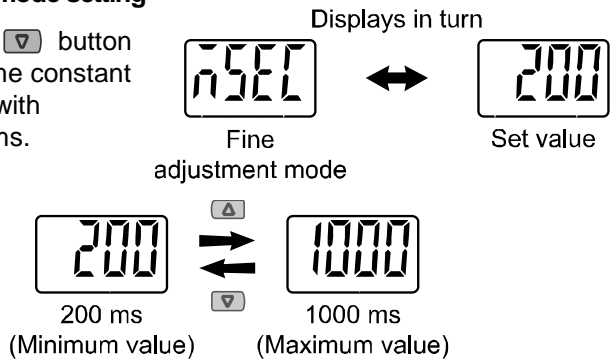

Press the button to set. ↓

(2) Delay time setting ("dt")

Press the Δ or ∇ button to select the response time of the switch output.

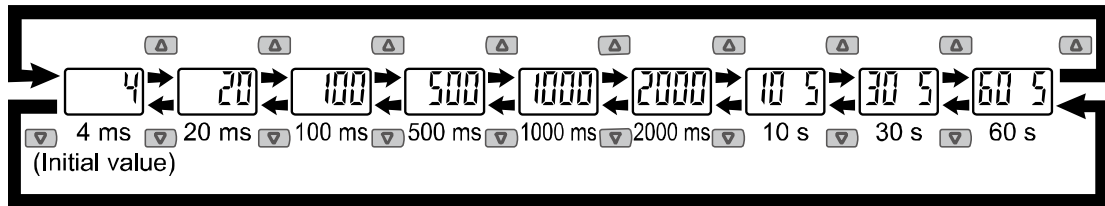
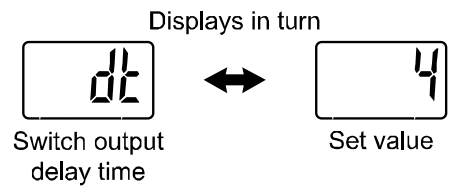

Press the **S** button to set. \downarrow Return to function selection mode.



Setting of [F 3] Response time completed



*: Measurement mode can be returned from any setting item by pressing the **S** button for 2 seconds or longer.

■[F 4] Display resolution



This function is used to change the pressure display resolution.
This can be used to prevent the digits from flickering on the display.

<Operation>

Press the  or  button in function selection mode to display [F 4].



Press the  button.  Move on to setting of display resolution.

Setting of display resolution

Press the  or  button to select display resolution.



1000-split







100-split



Display resolution





Set value

Displays in turn

Press the  button to set.  Return to function selection mode.

Setting of [F 4] Display resolution completed

*: Not selectable depending on the selected display units.

Setting of display resolution may not be available depending on the units for display.

Part Number	Rated value	kPa	Pa	mbar	psi	inHg	mmHg	inH ₂ O	mmH ₂ O
X576	±500 Pa	○	×	○	○	○	○	○	○
X577	±1 kPa	○	×	○	○	○	○	○	○
X578	±2 kPa	○	×	○	○	○	○	○	×
X579	±5 kPa	○	-	○	○	○	○	○	×
X580	±10 kPa	○	-	○	○	○	○	○	×

○: Setting available



×: Setting not available

-: No units for display

■[F 5] Auto-preset function

When hysteresis mode is selected, the auto-preset function can calculate an optimum pressure value automatically based on the on-going operation.

<Operation>

Press the  or  button in function selection mode to display [F 5].

Press the  button.  Move on to setting of auto-preset.

Setting of Auto-preset

Press the  or  button to select auto-preset.

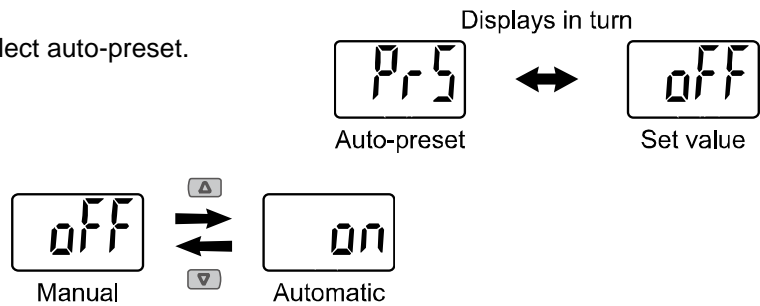

Press the  button to set.  Return to function selection mode.

Setting of [F 5] Auto-preset function completed

Press the  button during measurement mode to set the pressure.

Then press the  button again to change the pressure setting, while the display is flashing.

•Auto-preset

When auto-preset is selected in function selection mode, the set pressure can be calculated and stored from a measured pressure value. The set value is automatically optimized by repeating the suction and release of the workpiece during setting.

1, Selection of auto-preset OUT1

Press the **S** button in measurement mode to display "AP1".
 (If OUT1 does not need to be set, press the **Δ** and **▽** buttons simultaneously for 1 second or longer to move to "AP2").



Auto-preset is ready

2, Preparation of OUT1 device

Prepare the device for which the pressure of OUT1 is to be set.

3, Setting of auto-preset value for OUT1

Press the **S** button to display "A1L".
 After measurement starts, operate the device and change the pressure.
 When the pressure change is detected, "A1H" will appear automatically, and so continue to operate the device.
 (If the **Δ** and **▽** buttons are pressed simultaneously for 1 second or longer while "A1L" is displayed, measurement is stopped and "AP2" will appear).



Auto-preset is being set

4, Selection of auto-preset OUT2

Press the **S** button to set "P_1" and "H_1" ("n_1" and "H_1" for reversed mode) and display "AP2".
 (If OUT2 does not need to be set, press the **Δ** and **▽** buttons simultaneously for 1 second or longer to return to measurement mode).

5, Preparation and setting of OUT2 device

Prepare the device for which the pressure of OUT2 is to be set, and perform the setting of OUT2 in the same way as for OUT1.
 After "A2L" is displayed and measurement starts, the pressure change will be detected, and "A2H" will appear automatically.
 (If the **Δ** and **▽** buttons are pressed simultaneously for 1 second or longer when "A2L" is displayed, measurement is stopped and the display will return to measurement mode).

6, Completion of setting

Press the **S** button to set "P_2" and "H_2" ("n_2" and "H_2" for reversed output) and complete auto-preset mode. After that, the display will return to measurement mode.

The set values for OUT1 are displayed in auto-preset mode as follows:

<p>•Normal output</p> <p>$P_1 = A - (A - B) / 4$</p> <p>$H_1 = (A - B) / 2$</p>	<p>•Reversed output</p> <p>$n_1 = B + (A - B) / 4$</p> <p>$H_1 = (A - B) / 2$</p>	<p>A = Max. pressure</p> <p>B = Min. pressure</p>
---	---	---



The set values of OUT2 become as follows "_", i.e. "P_2", "n_2", "H_2".



If this setting is not necessary, press the **Δ** and **▽** buttons simultaneously for 1 second or longer.

■[F 6] Fine adjustment of display value

This function is used to manually perform fine adjustment of the displayed pressure. It is adjustable within the range $\pm 5\%$ R.D.

<Operation>

Press the  or  button in function selection mode to display [F 6].



Press the  button.  Move on to setting of fine adjustment of display value.

Setting of fine adjustment of display value

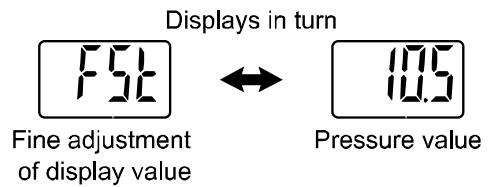
Press the  or  button to change the set pressure value.



Press the  button to set 

If the  and  buttons are pressed simultaneously for 1 second or longer while [F5C] is displayed, the adjusted value is set.

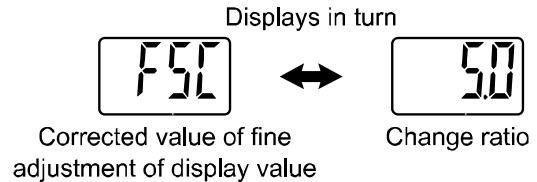

Press the  button to set.  Return to function selection mode.



Setting of [F 6] Fine adjustment of display value completed



■[F 7] Power saving mode

Power saving mode is selectable.



When the Pressure switch is left for 30 seconds with no key operation, it will enter power saving mode.

<Operation>

Press the  or  button in function selection mode to display [F 7].

Press the  button.  Move on to setting of power saving mode.

Setting of power saving mode

Press the  or  button to select power saving mode.

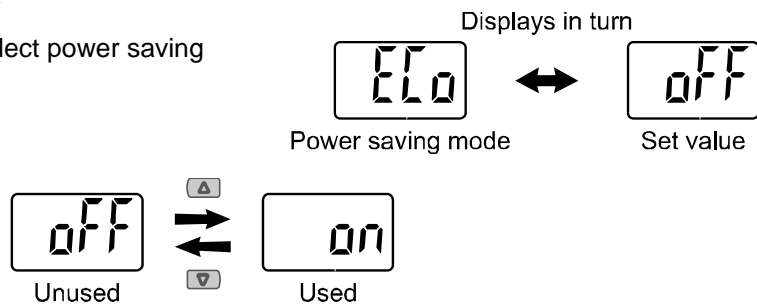

Press the  button to set.  Return to function selection mode.

Setting of [F 7] Power saving mode completed

In power saving mode, any key operation will return the normal display. If there is no key operation for 30 seconds, the display will return to power saving mode (only in measurement mode).

In power saving mode, only the decimal points and indicator LEDs will flash (the LEDs flash only when the switch is ON).

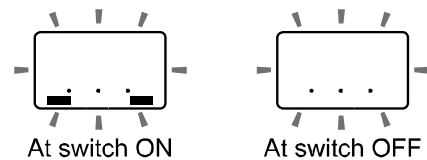



*: The indicator LEDs will flash when the switch is ON, but it is not synchronized with the output.

■[F 8] Security code

A security code can be selected, which must be entered to unlock the keys when the keys are locked.

<Operation>

Press the  or  button in function selection mode to display [F 8].

Press the  button. ↓ Move on to setting of security code.

Setting of security code

Press the  or  button to select security code.

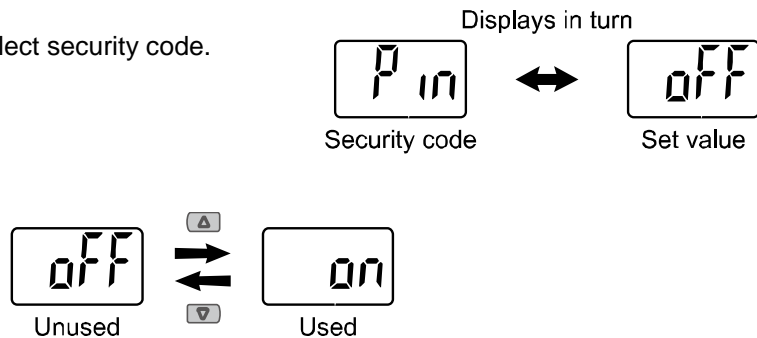

Press the  button to set. ↓ Return to function selection mode.

Setting of [F 8] Security code completed

If the security code is used, it becomes necessary to enter the security code to release the key lock. The security code can be decided optionally by the operator. The default setting is "0000".

Refer to page 47 for the security code input.

■ [F 9] Setting of low-cut function

This function is used to prevent display flicker at atmospheric pressure.

The displayed value of the pressure range in the table below will be "0" when the low-cut function is on.

Low-cut function



Part number	Rated value	kPa	Pa	mbar	psi	inHg	mmHg	inH ₂ O	mmH ₂ O
X576	±500 Pa	±0.003	±3	±0.03	x	±0.001	±0.02	±0.01	±0.3
X577	±1 kPa	±0.005	±5	±0.05	±0.001	±0.001	±0.04	±0.02	±0.5
X578	±2 kPa	±0.01	±10	±0.1	±0.001	±0.003	±0.1	±0.04	±1
X579	±5 kPa	±0.03	-	±0.3	±0.004	±0.01	±0.2	±0.1	±3
X580	±10 kPa	±0.05	-	±0.5	±0.01	±0.01	±0.4	±0.2	±5

x: Low-cut function not available

-: No units for display

<Operation>

Press the  or  button in function selection mode to display [F 9].

Press the  button.  Move on to the setting of the low-cut function.

Setting of low-cut function

Press the  or  button to select low-cut function.

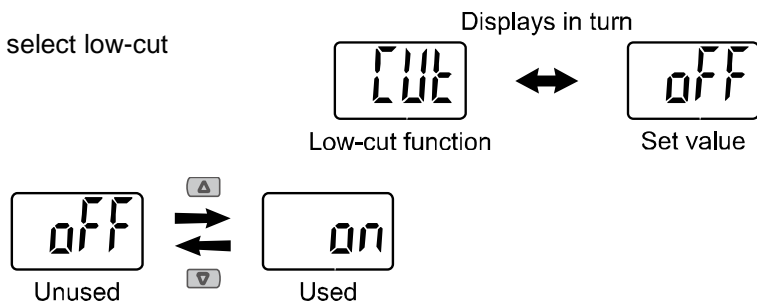

Press the  button to set.  Return to function selection mode.

[F 9] Low-cut setting completes



*: Measurement mode can be returned from any setting items by pressing and holding the S button for 2 seconds or longer. 

■ Special function setting

■ [F90] Setting of all functions

All functions can be set, one after the other.

<Operation>

Press the  or  button in function selection mode to display [F90].

Press the  button. ↓ Move on to setting of all functions.

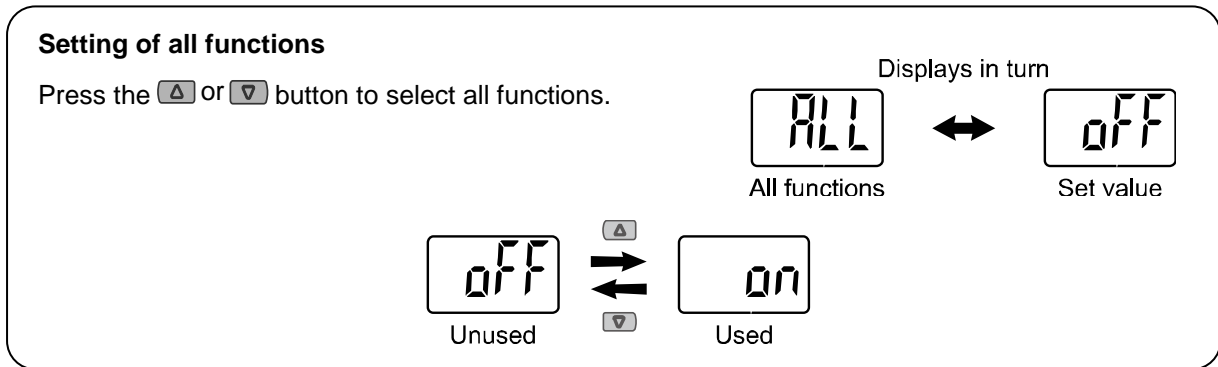

[oFF] (unused) selected.

Press the  button to set.

Return to function selection mode.

↓ [on] (used) selected

Setting of each function *1

After the change to [oFF] (unused),
press the  button to set.

Return to function selection mode.

Press the  button for 2 seconds or longer.

[F90] Setting of all functions completed

Measurement mode

*1: Setting of functions

Every time the  button is pressed, the function steps in the order of Function setting on page 40.

Set using the  or  buttons.

Refer to each section for further details of the setting.

•Order of Function setting

Order	Function	Applicable model
1	Selection of display unit	All models
2	Select output mode (OUT1)	All models
3	Select reversed output (OUT1)	All models
4	Setting of pressure (OUT1)	All models
5	Setting of hysteresis (OUT1)	All models
6	Setting of display colour	All models
7	Select output mode (OUT2)	Only for the product with output specification of NPN2 and PNP2
8	Select reversed output (OUT2)	
9	Setting of pressure (OUT2)	
10	Setting of hysteresis (OUT2)	
11	Response time	All models
12	Display resolution	All models
13	Auto-preset function	All models
14	Fine adjustment of display value	All models
15	Power saving mode	All models
16	Security code	All models
17	Setting of low-cut function	All models

*: Measurement mode will return from any setting by pressing the **S** button for 2 seconds or longer.

*: Function that will be set by the return to the measurement mode.

■[F97] Copy function

The set values of pressure and functions (except for corrected value of fine adjustment of display value) can be copied. When the pressure range, output and unit specifications are the same, this function becomes available. The set value can be copied to up to 10 pressure switches simultaneously.

<Connection>

Connect the Pressure switches with the power supply turned off.

Connect the FUNC terminals of the master Pressure switch and the slave Pressure switches, and then turn on the power supply.

The master Pressure switch is the switch from which the setting is to be copied.

The slave Pressure switch is the switch to which the setting is to be copied.

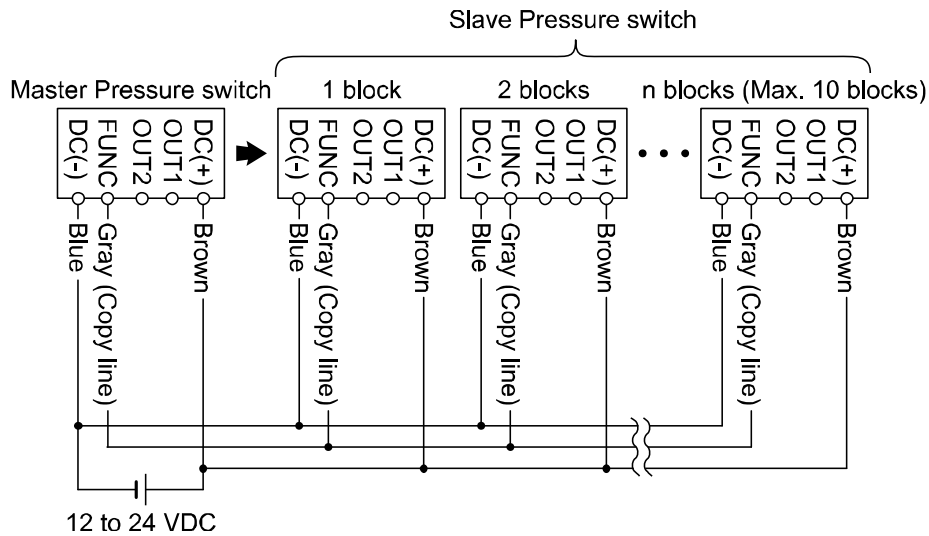

<Operation>

Press the **▲** or **▼** button of the master Pressure switch in function selection mode to display [F97].

Press the **S** button. **↓** Move on to the selection of copy function.

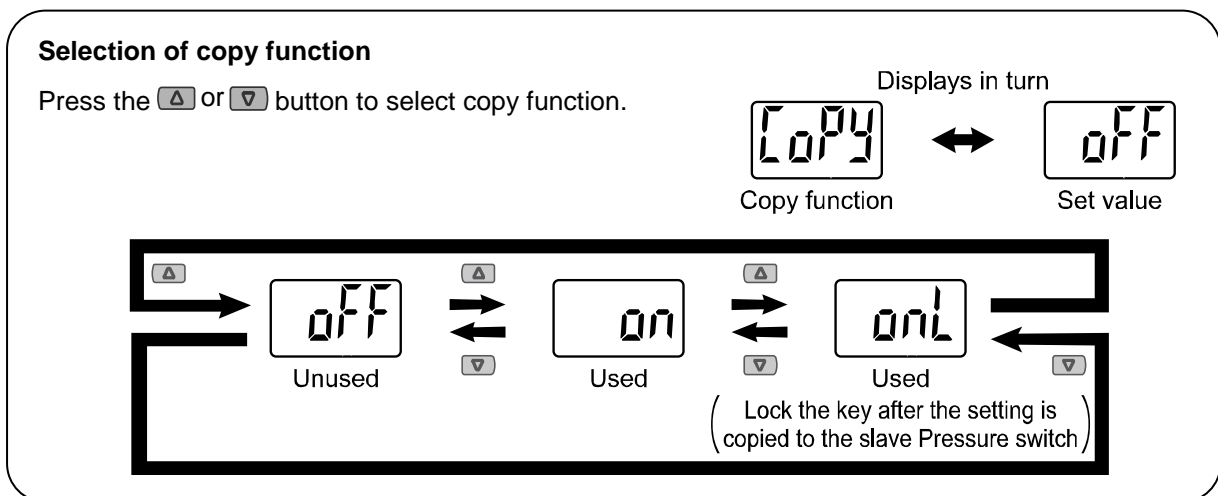





Press the **S** button to set. **↓**

 Copy is ready (Red)

The copy ready status is held even if the power supply is turned off.

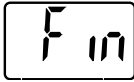
Press the **S** button to start copying. ↓

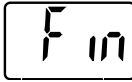
	The master Pressure switch	The slave Pressure switch
Sending/ Receiving	 Flashing (Red)	 Flashing (Green)
Copy completed	Displays in turn  ↔  (Red)	Displays in turn  ↔  (Green)

Press the **S** button.

The copy can be made continuously and the copy ready status can be held even if the power supply is turned off.

 Copy is ready (Red)

Press the **Δ** and **▽** buttons simultaneously for 1 second or longer.

Press the **S** button.

To complete the copy function, press the **Δ** and **▽** buttons simultaneously for 1 second or longer.

Setting of [F97] Copy function completed

*: If the copy to the slave pressure switch is not completed, it is detected as a copy function sending/receiving error. Press the **Δ** and **▽** buttons simultaneously for 1 second or longer to return to measurement mode. Then, check the wiring and specifications of the switch and retry the copy function.

■[F98] Check of output

<Operation>

Press the or button in function selection mode to display [F98].

Press the button. ↓ Move on to check of output.

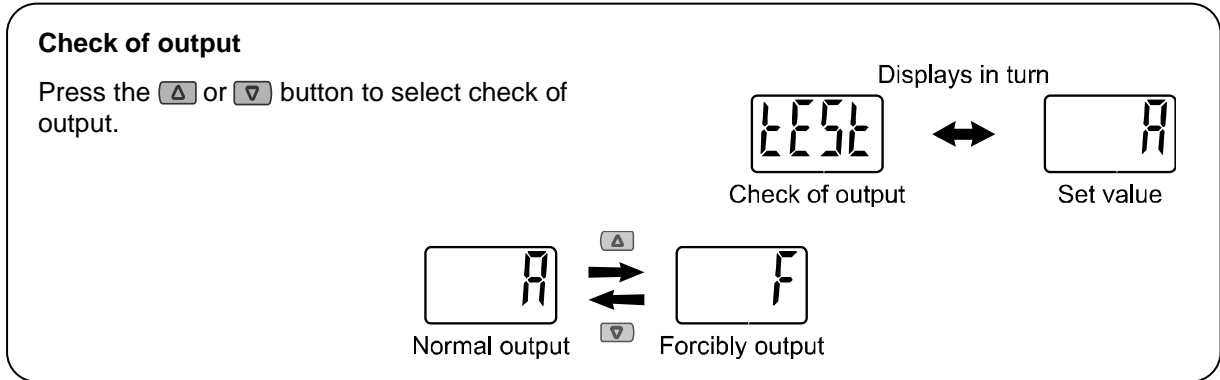

If [A] (normal output) is selected,

Press the button to set.

Return to function selection mode.

If [F] (forcibly output) is selected.

Press the button to set.

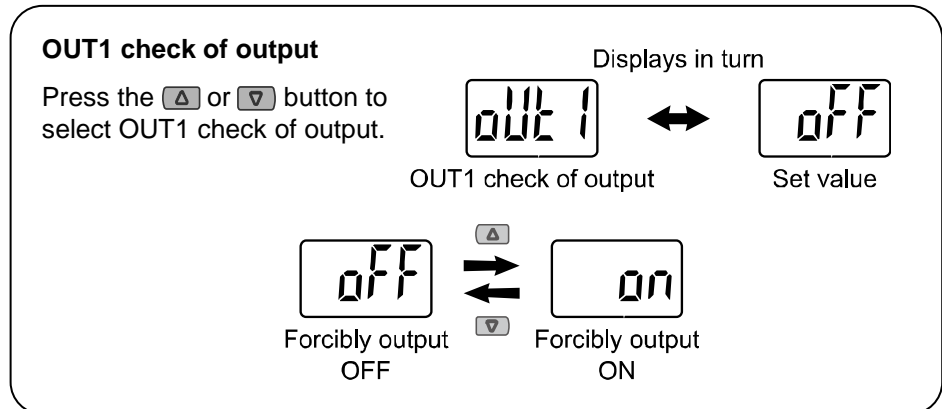

If OUT2 output is not provided,

press the button to set after returning to [A] (normal output).

Return to function selection mode.

If OUT2 output is provided,

press the button to set.

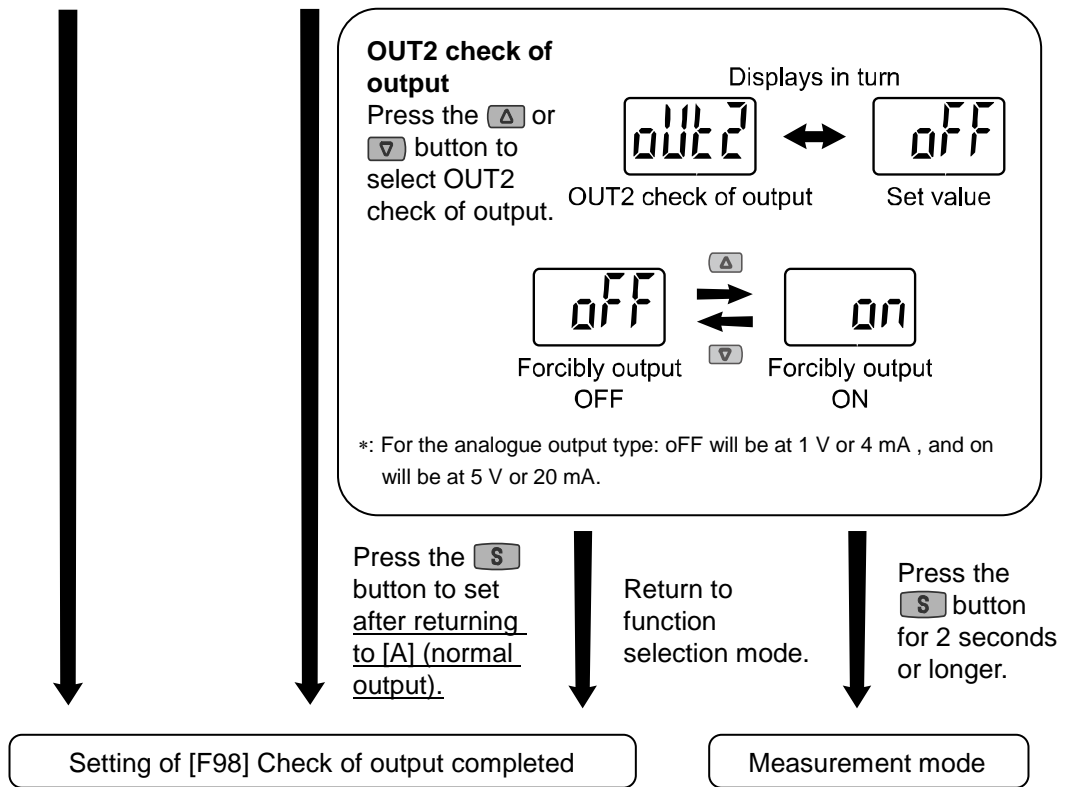



*: If the button is pressed for 2 seconds or longer, the mode is returned to measurement mode regardless of the current mode.

■[F99] Reset to the default setting

If the setting of the pressure switch becomes unknown, the default setting can be restored.

<Operation>

Press the  or  button in function selection mode to display [F99].

Press the  button. ↓ Move on to reset to the default setting.

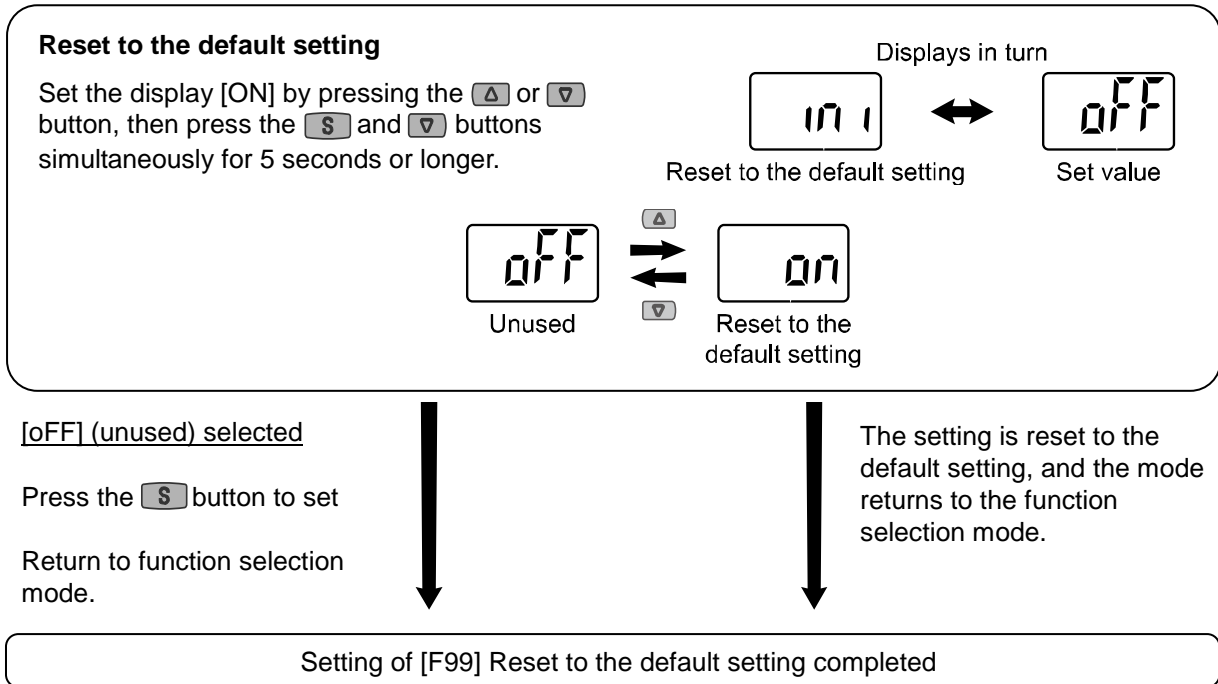



Other Settings

○Peak/Bottom value display



The maximum (minimum) pressure from when the power was supplied to this moment is detected and updated. In peak/bottom display mode, this pressure is displayed.

For peak display, when the  button is pressed for 1 second or longer, the maximum pressure and "Hi" starts flashing, and is held.

To release holding the display of the maximum pressure, press the  button for 1 second or longer again to return to measurement mode.

For bottom display, when the  button is pressed for 1 second or longer, the minimum pressure and "Lo" starts flashing, and is held.



To release holding the display of the minimum pressure, press the  button for 1 second or longer again to return to measurement mode.

If the  and  buttons are pressed simultaneously for 1 second or longer while the pressure is being held, the maximum (minimum) values are reset.

○Zero clear

The displayed value can be adjusted to zero when the measured pressure is within $\pm 3.5\%$ F.S. of the pressure, at the time of shipment from the factory.

(A tolerance range of $\pm 1\%$ F.S. may apply due to individual product differences).

Press the  and  buttons simultaneously for 1 second or longer, to clear the display to "0".

The display will return to measurement mode automatically.

For analogue output, the analogue output will be changed along with the display.

○Key lock

The key lock function is used to prevent errors occurring due to unintentional changes of the set values. If a button operation is performed while the key lock setting is ON, "LoC" is displayed for approximately 1 second.

(When the  button is pressed, the set pressure will be displayed following "LoC").



<Operation - Without security code input- >

- 1, Press the  button for 5 seconds or longer in measurement mode.

The current setting "LoC" or "UnL" will be displayed.

(Selecting or releasing the key lock is carried out in a similar way).



- 2, Press the  or  button to select key lock (or key unlock).

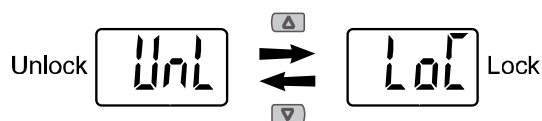

- 3, Press the  button to store the setting.

<Operation - With security code input- >

•Locking

- 1, Press the **[S]** button for 5 seconds or longer in measurement mode.
The current setting "UnL" is displayed.



- 2, Press the **[Δ]** or **[▽]** button to select keys lock "LoC".

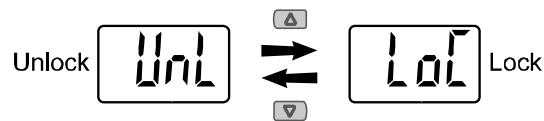

- 3, Press the **[S]** button to store the setting.

•Unlocking

- 1, Press the **[S]** button for 5 seconds or longer in measurement mode.
The current setting "LoC" is displayed.



- 2, Press the **[Δ]** or **[▽]** button to select keys unlock "UnL".

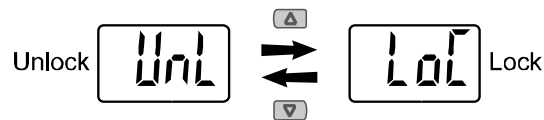

- 3, When the **[S]** button is pressed, input of the security code will be requested.
For how to enter the security code, refer to "How to enter the security code" on page 48.



- 4, If the security code entered is correct, the display will change to "UnL". Press any of the **[Δ]**, **[S]** or **[▽]** buttons to release the key lock and return to measurement mode.
If the security code entered is incorrect, "FAL" will be displayed and the security code must be entered again. If an incorrect security code is entered three times, "LoC" is displayed and the display will return to measurement mode.

•How to change the security code

At the time of shipment, the security code is set to "0000", but this can be changed to any number.

<Operation>

- 1, After the key lock setting has been completed, perform the first three steps in the unlocking procedure (page 47).
- 2, After the security code has been entered and the display changes to "UnL", press the **S** and **▽** buttons simultaneously for 5 seconds or longer.
"0000" is displayed and a new security code can now be entered.
For how to enter the security code, refer to "How to enter the security code".
The new security code will be displayed.
- 3, After checking the security code is as required, press the **S** button for 1 second or longer.
The display will return to measurement mode.
At this time, if the **△** or **▽** button is pressed, any security code changes are lost, and the change of security code procedure must be repeated.



•How to enter the security code

The first digit will start flashing.
Press the **△** or **▽** button to select a value.
Press the **S** button to set and the next digit will start flashing.
(If the **S** button is pressed at the last digit, the first digit will start flashing again).

After the setting is completed, press the **S** button for 1 second or longer.
(If a key operation is not performed for 30 seconds while entering the security code, the measurement mode will return).

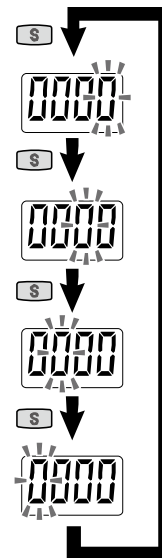

Maintenance

How to reset the product after a power cut or forcible de-energizing

The setting of the product will be retained as it was before a power cut or de-energizing.

The output condition is also basically recovered to that before a power cut or de-energizing, but may change depending on the operating environment.

Therefore, check the safety of the whole installation before operating the product.

If the installation is using accurate control, wait until the product has warmed up (approximately 10 to 15 minutes).

If the security code is forgotten

The following procedure can be used when the security code has been forgotten.

<Operation>

Press the **S** button for 5 seconds or longer in measurement mode.
The current setting "UnL" or "LoC" is displayed.



Press the **Δ** and **▽** buttons simultaneously for 5 seconds or longer.
Then, press the **S** and **▽** buttons simultaneously for 5 seconds or longer.

*: There will be no change to the display.

(at this time, if another operation is performed or no key operation is performed for 30 seconds, the display will return to measurement mode).

Press the **Δ** and **S** buttons simultaneously for 5 seconds or longer. The display will change to "0000" and the security code change mode will return.

(at this time, if another operation is performed or no key operation is performed for 30 seconds, the display will return to measurement mode).

Refer to "How to change the security code" (page 48) and select a new security code.

The new security code will be displayed.

Check the security code is as required, and press the **S** button for 1 second or longer.

The display will return to measurement mode.

At this time, if the **Δ** or **▽** button is pressed, any security code changes will be lost, and the change of security code procedure must be repeated.

Troubleshooting

If the cause of the failure cannot be identified and normal operation can be recovered by replacement with a new Pressure switch, this indicates that the Pressure switch itself is faulty. Pressure switch damage can be caused by the operating environment (network construction, etc.), therefore contact SMC.

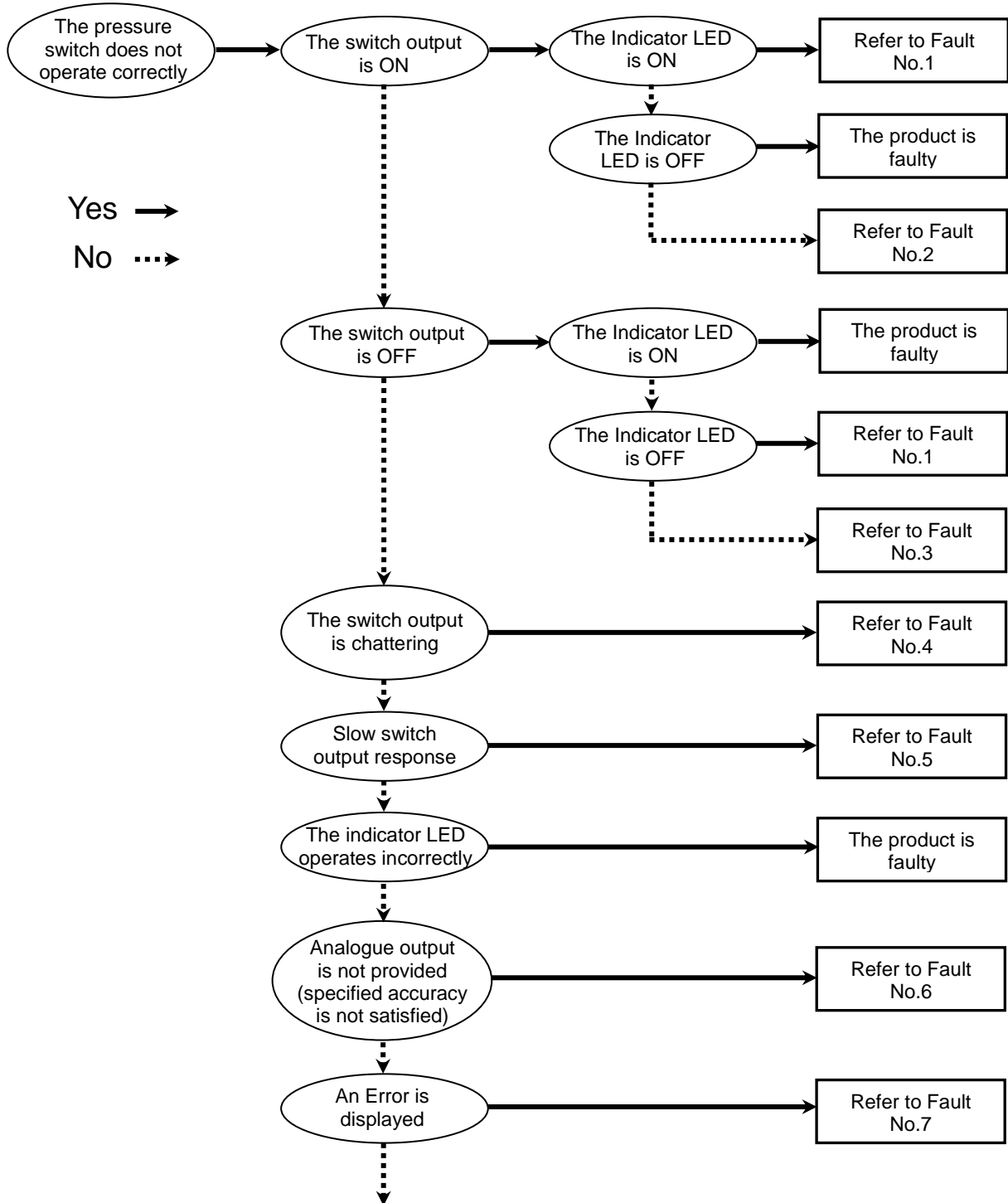

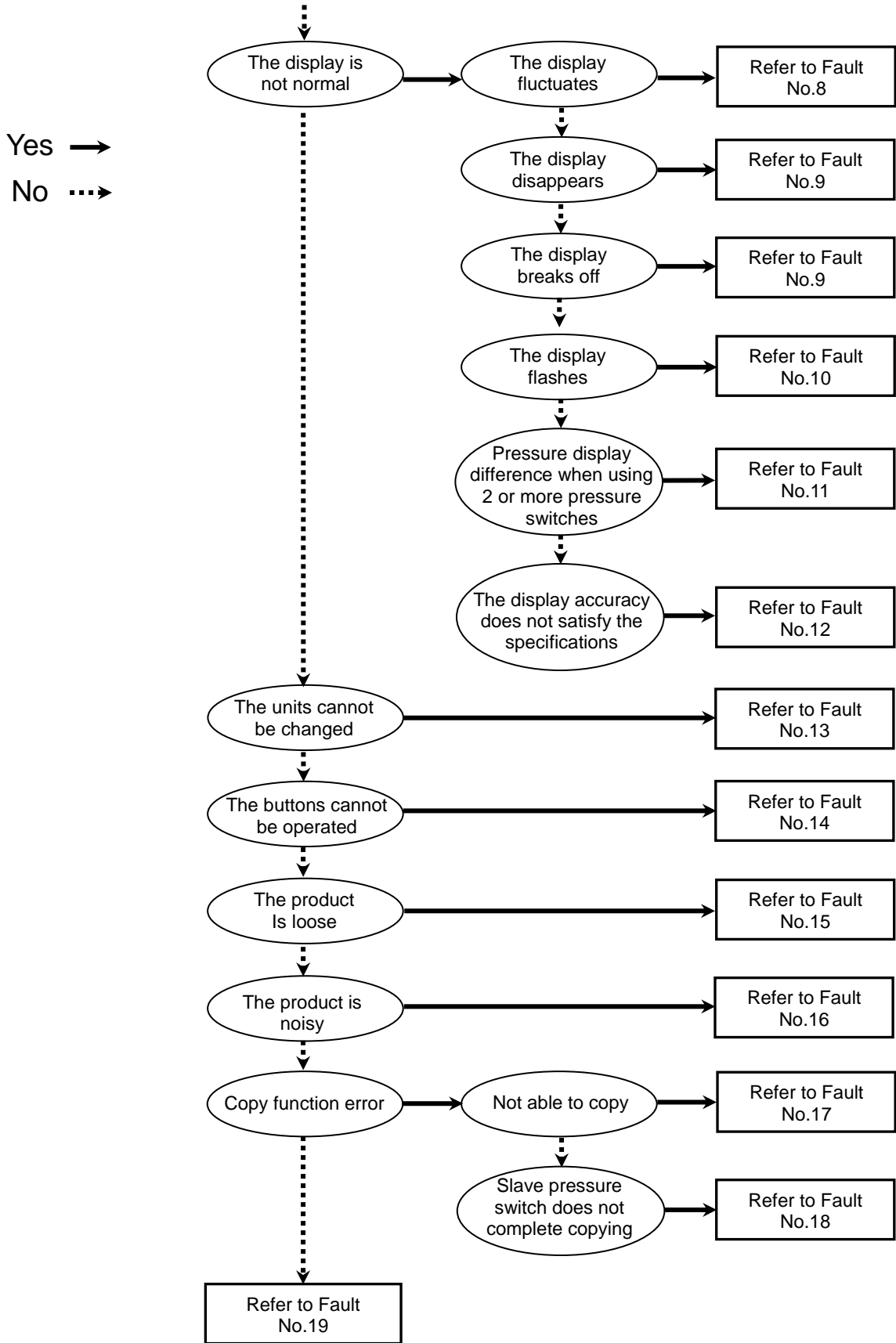

○ Faults and countermeasures

Fault No.	Fault	Possible cause	Investigation method	Countermeasure
1	<ul style="list-style-type: none"> •Output remains ON. Indicator LED remains ON. •Output remains OFF. Indicator LED remains OFF. 	Incorrect pressure setting	(1) Check the set pressure. (2) Check the operation mode, hysteresis and output type. (hysteresis mode / window comparator mode, normal / reversed output)	(1) Reset the pressure setting. (2) Reset the function settings.
		Product failure		Replace the product.
2	Output remains ON. Indicator LED works correctly.	Incorrect wiring	Check the wiring of the output. Check if the load is connected directly to DC(+) or DC(-).	Correct the wiring.
		Product failure		Replace the product.
3	Output remains OFF. Indicator LED works correctly.	Incorrect wiring	Check the wiring of the output. Check if the load is connected directly to DC(+) or DC(-).	Correct the wiring.
		Unsuitable model selection	Check if PNP is used when NPN should have been selected, or the other way around.	Review the selected model (output type).
		Broken lead wire	Check if there is bending stress applied to any parts of the lead wire. (bending radius and tensile force applied).	Correct the wiring conditions. (adjust the tensile force and increase the bending radius).
		Product failure		Replace the product.
4	Switch output generates chattering.	Incorrect wiring	Check the wiring. Check that the brown and blue wires are connected to DC(+) and DC(-) respectively, and if the output wiring is loose (contact failure).	Correct the wiring.
		Incorrect settings	(1) Check the set pressure. (2) Check that the hysteresis range is not too narrow. (3) Check the digital filter and delay time setting. Check if the digital filter and delay time are too short.	(1) Reset the pressure setting. (2) Increase the hysteresis. (3) Reset the function settings.
		Product failure		Replace the product.
5	Slow switch output response	Incorrect pressure setting	Check the pressure setting. Check that the detected pressure and the set pressure value are not the same or not too close.	Reset the pressure setting. Set the pressure setting value so it is not too close to the detected pressure.

Fault No.	Fault	Possible cause	Investigation method	Countermeasure
6	Analogue output (OUT2) is not provided. (specified accuracy is not satisfied).	Incorrect wiring	Check that the analogue output (OUT2) is connected to a load.	Correct the wiring.
		Non-compliance with the load specification.	(1) Check that the correct load is connected. (2) Check that the impedance of the input equipment (A/D transformer) is suitable.	Connect a suitable load.
		Insufficient warm-up time	Check if the product satisfies the specified accuracy after 10 minutes warm up time.	After energizing, the display and output can drift. For detecting fine pressures, warm up the product for 10 to 15 minutes.
		Product failure		Replace the product.
7	<ul style="list-style-type: none"> •An over current error (Er1, Er2) is displayed. •System error (Er0, Er4, Er6, Er7, Er8 or Er9) is displayed. •The display shows "HHH". •The display shows "LLL". •Residual pressure error (Er3) is displayed. 	Over current to the output (Er1, Er2)	(1) Check that the switch output load current is not more than 80 mA. (2) Check that the connected load satisfies the specifications, and check the load for short circuits. (3) Check that any relay is connected with a surge voltage suppressor. (4) Check if the wiring is not in the same route as (or bundled together with) a high voltage cable or power cable.	(1), (2) Connect the load as specified. (3) Use a relay with a surge voltage suppressor or take measures to prevent noise. (4) Separate the wiring route from any high voltage cable or power cable.
		Incorrect operation of the internal data of the Pressure switch (Er0, Er4, Er6, Er7, Er8, Er9)	(1) Check that there is no noise interference such as static electricity, and check for noise sources. (2) Check that the power supply voltage is within the range 12 to 24 VDC $\pm 10\%$.	(1) Remove the noise and the noise source (or take measures to prevent noise interference), and reset the product, or turn off the power supply and turn it on again. (2) Supply a correct voltage of 12 to 24 VDC $\pm 10\%$.
		Applied pressure is above the upper limit (HHH).	(1) Check that the pressure is not above the upper limit of the set pressure range. (2) Check that foreign matter has not entered the piping.	(1) Adjust the pressure to within the set pressure range. (2) Take measures to prevent foreign matter from entering the piping.
		Applied pressure is below the lower limit (LLL).	(1) Check that the pressure is not below the lower limit of the set pressure range. (2) Check that foreign matter has not entered the piping.	(1) Adjust the pressure to within the set pressure range. (2) Take measures to prevent foreign matter from entering the piping.
		Pressure is not atmospheric pressure at zero-clear operation (Er3)	Check that during the zero clear operation, pressure above $\pm 3.5\%$ F.S. was not applied.	Return the applied pressure to atmospheric pressure, and retry the zero clear operation.
		Product failure		Replace the product.

Fault No.	Fault	Possible cause	Investigation method	Countermeasure
8	Displayed value fluctuates.	Incorrect power supply	Check that the power supply voltage is within the range 12 to 24 VDC $\pm 10\%$.	Supply the correct voltage of 12 to 24 VDC $\pm 10\%$.
		Incorrect wiring	Check the wiring to the power supply. Check that the brown and blue wires are connected to DC(+) and DC(-) respectively and that the output wiring is not loose (contact failure).	Correct the wiring.
		Factory pressure change	Check if the factory pressure has changed.	If the fluctuation is not acceptable, the pressure switch display resolution can be changed.
		Product is exposed to the wind	Check if the product is exposed to the wind.	(3) Do not expose the product to the wind. (2) Change the number of digits by setting the display resolution.
9	<ul style="list-style-type: none"> •Display turns OFF. •Part of the display is missing. 	Incorrect power supply	Check that the power supply voltage is within the range of 12 to 24 VDC $\pm 10\%$.	Supply the correct voltage of 12 to 24 VDC $\pm 10\%$.
		Power saving mode	Check if the power saving mode is selected.	Reset the function settings.
		Incorrect wiring	Check the power supply wiring. Check that the brown and blue wires are connected to DC(+) and DC(-) respectively and that the output wiring is not loose (contact failure).	Correct the wiring.
		Product failure		Replace the product.
10	Display is flashing.	The peak / bottom value display mode is selected.	Check if the peak value or bottom value display mode has been selected.	Turn off the peak / bottom value display mode if not required.
		Wiring failure	(1) Check the power supply wiring. (2) Check if there is bending stress applied to any parts of the lead wire.	(1) Correct the wiring (2) Correct the wiring conditions (reduce the tensile force and increase the bending radius).
11	Pressure display difference when using 2 or more Pressure switches.	Dispersion within the display accuracy range	Check if the dispersion is within the display accuracy range.	Use the fine adjustment mode to adjust the display if the dispersion is within the display accuracy range.
		Product failure		Replace the product.

Fault No.	Fault	Possible cause	Investigation method	Countermeasure
12	The pressure display accuracy does not satisfy the specifications.	Foreign matter	Check if any foreign matter has entered the pressure port.	Install a 5 μm filter to prevent foreign matter from entering the pressure port. Also, clean the filter regularly to prevent drainage deposits.
		Air or fluid leakage	Check if air or fluid are leaking from the piping.	Rework the piping. If an excessive tightening torque is applied, the mounting bracket, screws or the product may be damaged.
		Insufficient warm-up time	Check if the product satisfies the specified accuracy after 10 minutes warm up time.	After energizing, the display and output can drift. For detecting fine pressures, warm up the product for 10 to 15 minutes.
		Product failure		Replace the product.
13	The display units cannot be changed.	Improper model selection (selection of model without "units selection function")	Check if there is an "-M" at the end of the part number printed on the product.	"M" in the part number means that the units cannot be changed. *: The unit change function is not available in Japan due to a new measurement law.
		Product failure		Replace the product.
14	The buttons cannot be operated.	Key lock mode	Check if the key lock mode is turned on.	Turn off the key lock mode.
		Product failure		Replace the product.
15	The product is loose.	Incorrect installation	Check that the panel mount adapter and the product are correctly assembled.	Mount the product on the panel correctly.
		Product failure		Replace the product.
16	The product is noisy.	Air or fluid leakage	Check if air or fluid are leaking from the piping.	Rework the piping. If an excessive tightening torque is applied, the mounting bracket, screws or the product may be damaged.
		Product failure		Replace the product.
17	<ul style="list-style-type: none"> •Copy function error •Unable to copy 	Incorrect wiring	(1) Check the wiring connection at the FUNC terminal. (2) Check the power supply wiring.	Correct the wiring.
		Product failure		Replace the product.

Fault No.	Fault	Possible cause	Investigation method	Countermeasure
18	Slave Pressure switch does not complete the copy function.	Incorrect wiring	(1) Check the wiring connection at the FUNC terminal. Check the power supply wiring. (2) Check the lead wire lengths.	(1) Correct the wiring. (2) The maximum transmitting distance of the copy function is 4 m. Shorten the lead wire to 4 m or less.
		Improper model selected	The model number of the master Pressure switch and the slave Pressure switch are different from each other.	Check the model numbers. Copying is available when the pressure range, output specification and units specification are identical.
		Too many pressure switches connected	Check the number of connected slave Pressure switches.	The number of connected products for which copying is possible is up to 10 pcs. Reduce the number to 10 pcs or less.
		Product failure		Replace the product.
19	The operation is unstable. (chattering)	Pressure source fluctuation, small hysteresis or the response time is too short.	(1) Check the set pressure (hysteresis) (2) Check the digital filter and delay time.	(1) Check the pressure setting. (2) Reset the function settings.
		Incorrect wiring or broken lead wire	(1) Check the power supply wiring. (2) Check if there is bending stress applied to any parts of the lead wire.	(1) Correct the wiring (2) Correct the wiring conditions (reduce the tensile force and increase the bending radius).
		Product failure		Replace the product.

○Error indication

This function is to display error location and content when a problem or an error occurs.

Error Name	Error Display	Error Type	Troubleshooting Method
Over current Error	Er1 Er2	The switch output load current is more than 80 mA.	Turn the power off and remove the cause of the over current. Then turn the power on.
Residual Pressure Error	Er3	During zero clear operation, pressure above $\pm 3.5\%$ F.S. has been applied. After 1 second, the mode will return to measurement mode. The zero clear range can vary $\pm 1\%$ F.S. with individual product differences.	Perform zero clear operation again after restoring the applied pressure to an atmospheric pressure condition.
Pressurizing Error	HHH	Pressure has exceeded the upper limit of the set pressure range.	Adjust the applied pressure to a level within the set pressure range.
	LLL	Pressure has exceeded the lower limit of the set pressure range.	
System Error	Er0 Er4 Er6 Er7 Er8 Er9	Displayed in the case of an internal data error.	Turn the power off and turn it on again. If resetting fails, an investigation by SMC Corporation will be required.

If the error can not be reset after the above measures are taken, then please contact SMC.

Specification

Model No.	X576	X577	X578	X579	X580
Rated pressure range	±500 Pa	±1.000 kPa	±2.00 kPa	±5.00 kPa	±10.00 kPa
Set pressure range (Refer to page 61)	±525 Pa	±1.050 kPa	±2.10 kPa	±5.25 kPa	±10.50 MPa
Withstand pressure	2.5 kPa	5 kPa	10 kPa	25 kPa	50 kPa
Smallest settable increment	1 Pa	0.001 kPa	0.01 kPa	0.01 kPa	0.01 kPa
Applicable fluid	Air, inert gases and incombustible gases				
Power supply voltage	12 to 24 VDC ±10%, ripple (p-p) 10% or less				
Current consumption	40 mA or less				
Digital filter	Rough adjustment mode: 0, 0.2, 0.5, 1, 2, 5, 10, 20 s Fine adjustment mode: 200 to 1000 ms (increments of 5 ms) *: The digital filter set value affects the response of the pressure display, analogue output and switch output. (See Figure on page 60)				
Switch output	NPN or PNP open collector output: 1 output				
	NPN or PNP open collector output: 2 outputs				
	Max. load current	80 mA			
	Max. applied voltage	28 V (NPN output)			
	Residual voltage	1 V or less (at 80 mA load current)			
	Delay time	4 ms or less (with anti-chatter function: 20 ms, 100 ms, 500 ms, 1000 ms, 2000 ms, 10 s, 30 s or 60 s selected)			
Short circuit protection	Provided				
Repeatability	±1%F.S. ±1 digit				
Hys teresis	Hysteresis mode	0 to variable *1			
	Window comparator mode				
OUT2	Voltage output *2	Output Voltage (rated pressure range)	1 to 5 V ±2.5%F.S.		
		Linearity	±1.5%F.S.	±1%F.S.	
		Output impedance	approx. 1 kΩ		
	Current output *3	Output current (rated pressure range)	4 to 20 mA ±2.5%F.S.		
		Linearity	±1.5%F.S.	±1%F.S.	
		Load impedance	Max. load impedance: 300 Ω (at power supply voltage of 12 VDC) 600 Ω (at power supply voltage of 24 VDC) Min. load impedance: 50 Ω		
Display	4 digits, 7-segment, dual-colour display (red/green)				
Display accuracy	±2%F.S. ±1digit (at ambient temperature 25±3 °C)				
Indicator LED	LED is ON when output is ON OUT1: Green OUT2: Red				

*1: If the applied voltage fluctuates around the set value, the hysteresis must be set to more than the fluctuation width. Otherwise, chattering will occur.

*2: If analogue voltage output is selected, the analogue current output cannot be selected.

*3: If analogue current output is selected, the analogue voltage output cannot be selected.

Model No.	X576	X577	X578	X579	X580
Environment	Enclosure				
	IP40				
	Ambient temperature range				
	Operation: 0 to 50 °C, Storage: -10 to 60 °C (no condensation or freezing)				
	Ambient humidity range				
Operation, Storage: 35 to 85%RH (no condensation)					
Withstand voltage					
1000 VAC, 1 minute between terminals and housing					
Insulation resistance					
50 MΩ or more at 500 VDC between terminals and housing					
Temperature characteristics					
±3%F.S. (25 °C reference)					
Lead wire					
Oil resistant vinyl cabtyre cable					
3 cores φ3.5, 2 m					
4 cores Sectional area of conductor: 0.15 mm ² (AWG26)					
Outside diameter of insulator: 1.0 mm					

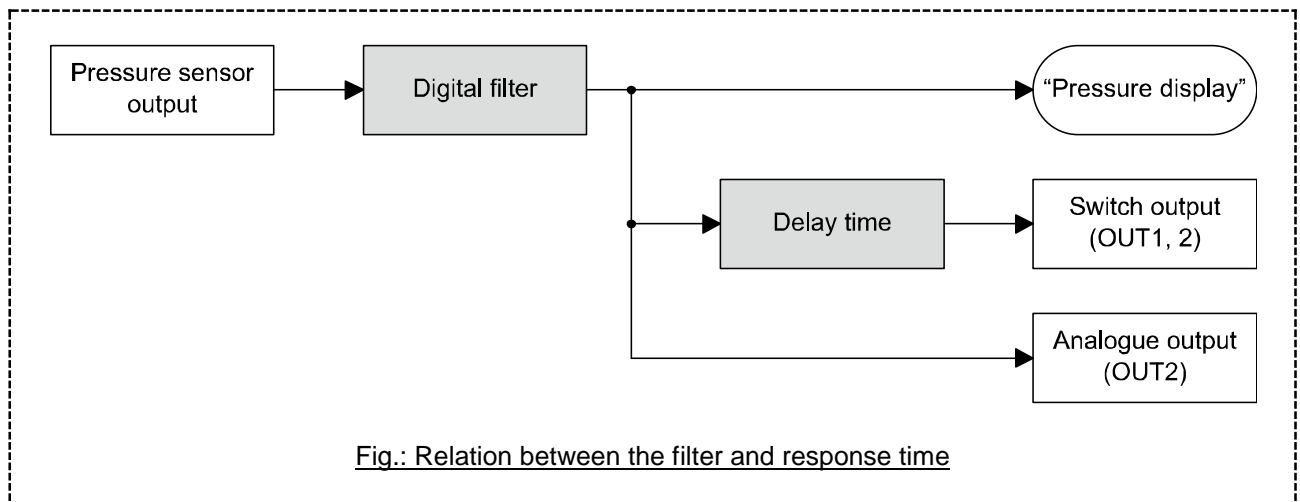

○Piping specifications

Model No.		01	N01
Port size		R1/8 M5 x 0.8	NPT1/8 M5 x 0.8
Material of wetted parts	Pressure sensing part	Silicone	
	Piping port	C3602 (electroless nickel plating) O-ring: HNBR	
Weight	With lead wire and connector attached (3-core, 2 m)	81 g	
	With lead wire and connector attached (4-core, 2 m)	85 g	
	Without lead wire and connector	43 g	

○Settable pressure range per unit

Part number	Rated value	kPa	Pa	mbar	psi	inHg	mmHg	inH ₂ O	mmH ₂ O
X576	±500 Pa	±0.525	±525	±5.25	±0.076	±0.155	±3.94	±2.11	±53.5
X577	±1 kPa	±1.050	±1050	±10.50	±0.152	±0.310	±7.88	±4.22	±107.1
X578	±2 kPa	±2.10	-1998 to 2100	±21.0	±0.305	±0.620	±15.8	±8.43	±214
X579	±5 kPa	±5.25	-	±52.5	±0.761	±1.55	±39.4	±21.1	±535
X580	±10 kPa	±10.50	-	±105.0	±1.52	±31.0	±78.8	±42.2	±1071

-: No units for display

○Analogue output

Voltage output

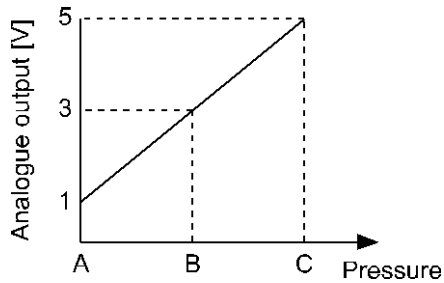

Current output

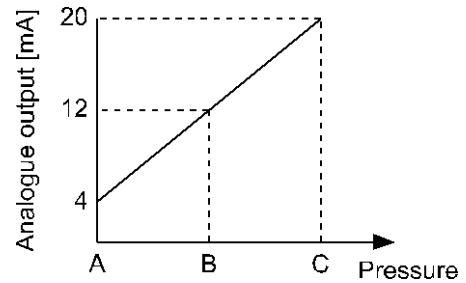

Range	Rated pressure range	A	B	C
X576	±500 Pa	-500 Pa	0 Pa	500 Pa
X577	±1 kPa	-1 kPa	0 kPa	1 kPa
X578	±2 kPa	-2 kPa	0 kPa	2 kPa
X579	±5 kPa	-5 kPa	0 kPa	5 kPa
X580	±10 kPa	-10 kPa	0 kPa	10 kPa

■Dimensions

○Body dimensions

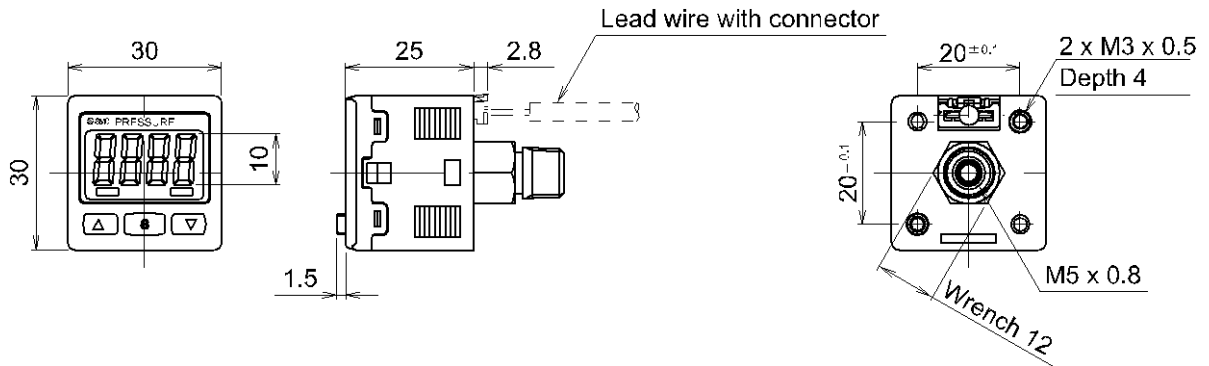

○Mounting brackets

●Bracket A

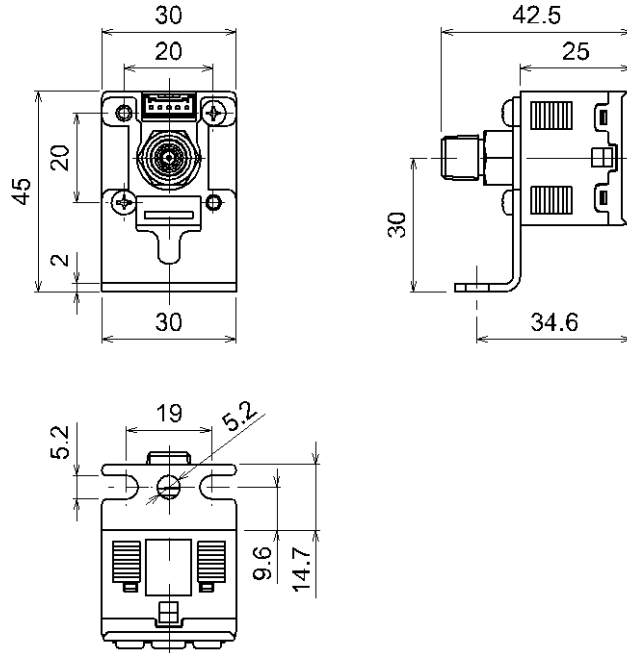

●Bracket B

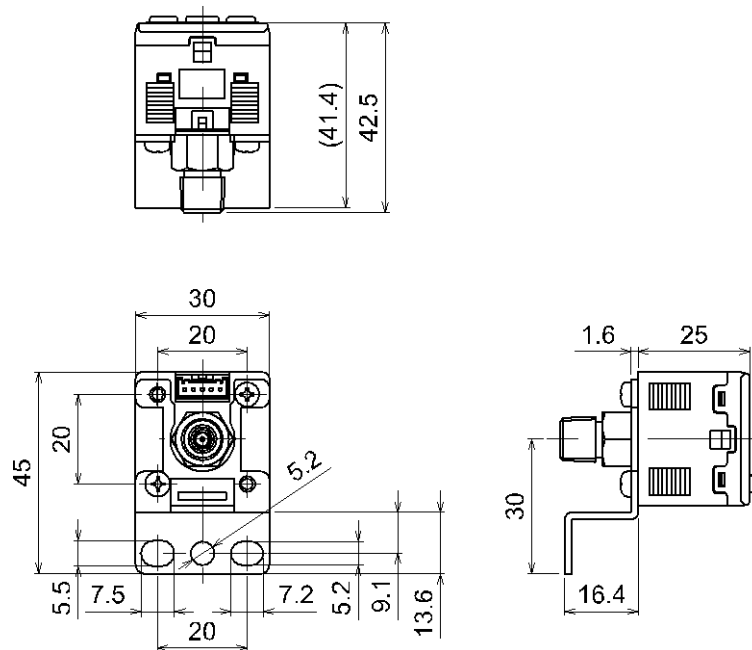

•Bracket C

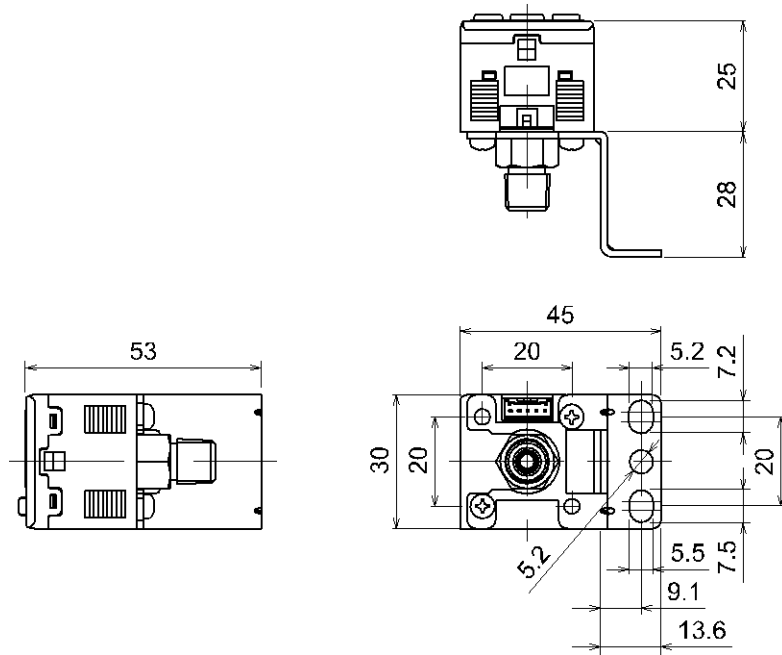

○Panel mount adapter

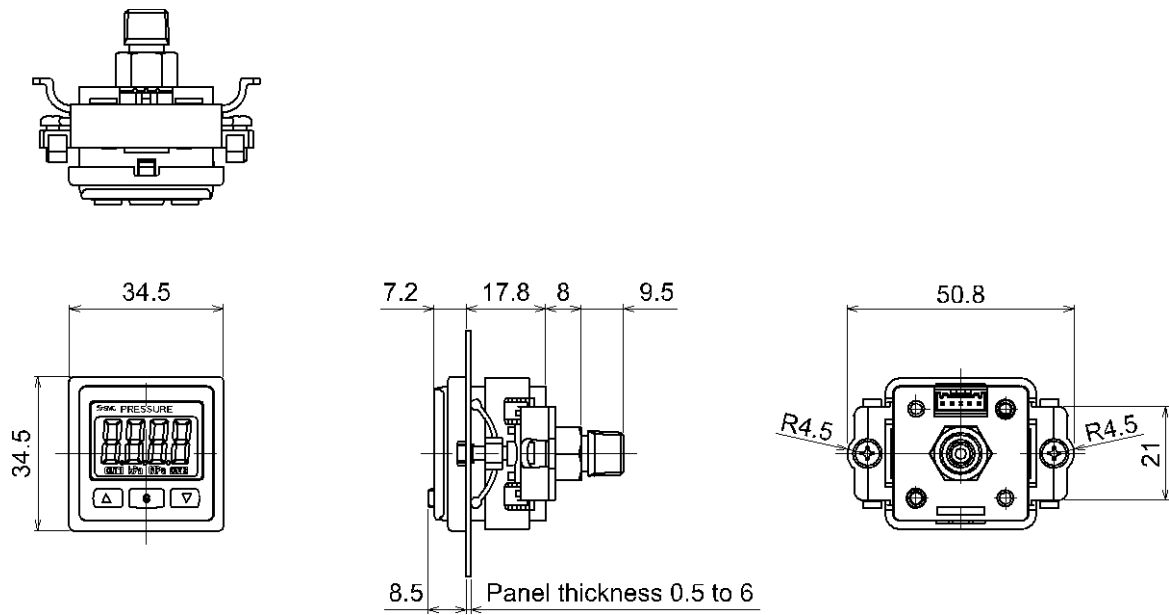

○Panel mount adapter + Front protective cover

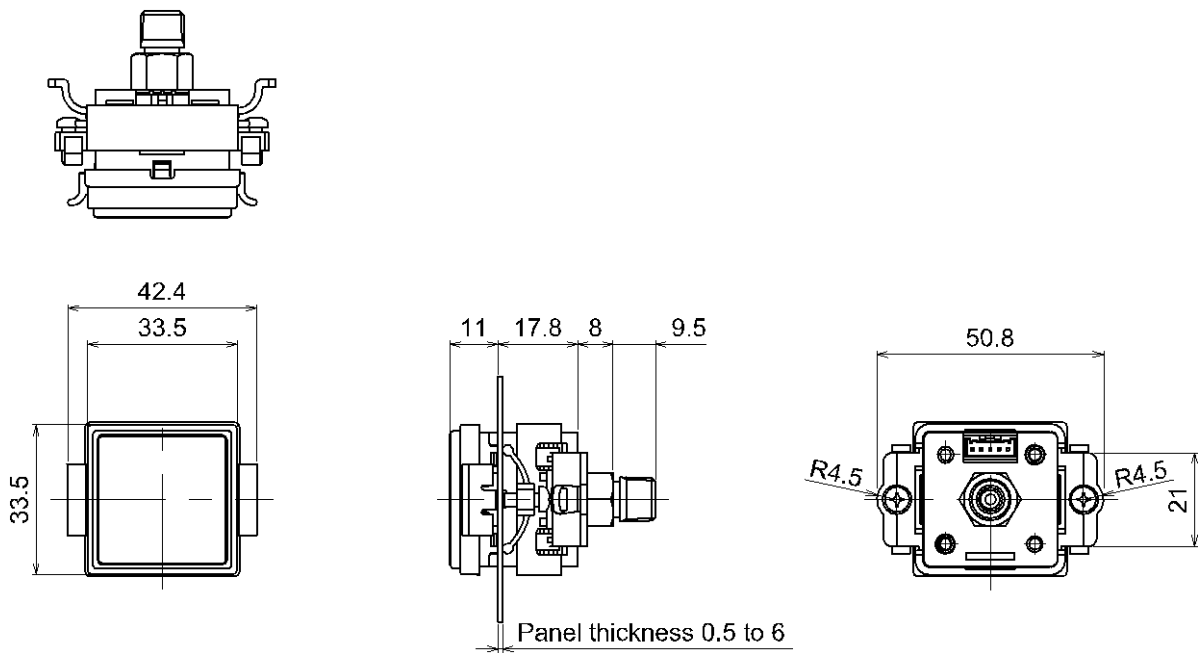

Panel cut-out dimensions

Single Pressure switch

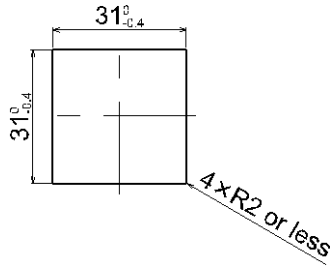

Two or more in a row

n: The number of the Pressure switch

<Horizontal>

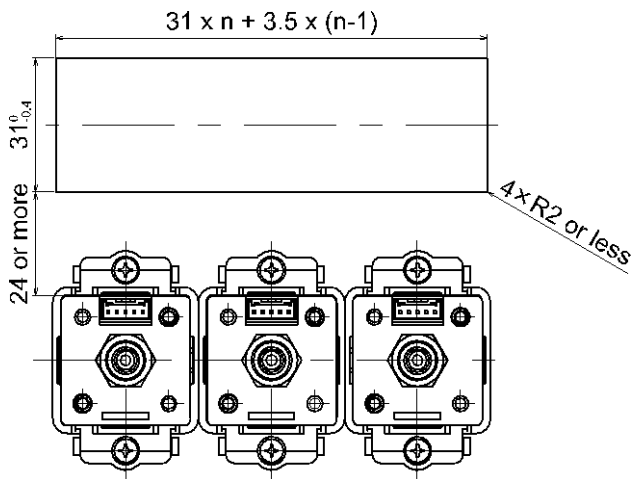

<Vertical>

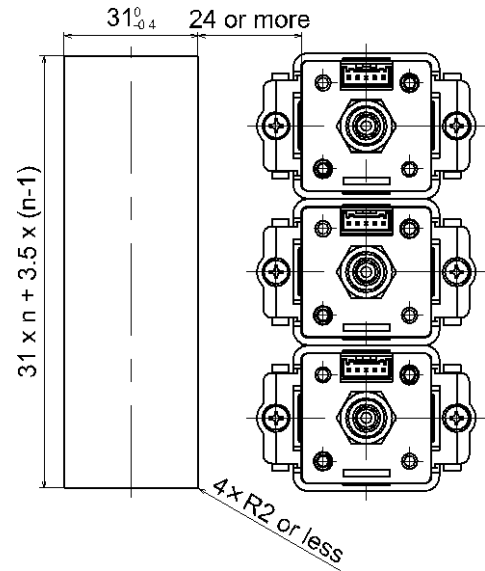

Revision history

A: Contents revised in several places. [July 2018]
B: Modified errors in text. [April 2019]

SMC Corporation

4-14-1, Sotokanda, Chiyoda-ku, Tokyo 101-0021 JAPAN

Tel: + 81 3 5207 8249 Fax: +81 3 5298 5362

URL <https://www.smcworld.com>

Note: Specifications are subject to change without prior notice and any obligation on the part of the manufacturer.
© 2017-2019 SMC Corporation All Rights Reserved

