



Operation Manual

PRODUCT NAME

High Vacuum L Type Valve

MODEL / Series / Product Number

XLS Series

SMC Corporation

Contents

Safety Instructions	-----	2
1. Precautions on handling 1 (Precautions on Design, Selection, Mounting, Piping, Maintenance)	-----	4
2. Precautions on handling 2 (Maintenance parts)	-----	5
3. Specifications	-----	7
4. Construction / Operatio	-----	8
5. Dimensions	-----	9
6. Period and Scope of Warranty	-----	10
7. Parts Replacement Procedure	-----	11



Safety Instructions

These safety instructions are intended to prevent hazardous situations and/or equipment damage. These instructions indicate the level of potential hazard with the labels of “Caution,” “Warning” or “Danger.” They are all important notes for safety and must be followed in addition to International Standards (ISO/IEC)*1), and other safety regulations.

*1) ISO 4414: Pneumatic fluid power -- General rules relating to systems.

ISO 4413: Hydraulic fluid power -- General rules relating to systems.

IEC 60204-1: Safety of machinery -- Electrical equipment of machines .(Part 1: General requirements)

ISO 10218-1992: Manipulating industrial robots -Safety.

etc.



Caution

Caution indicates a hazard with a low level of risk which, if not avoided, could result in minor or moderate injury.



Warning

Warning indicates a hazard with a medium level of risk which, if not avoided, could result in death or serious injury.



Danger

Danger indicates a hazard with a high level of risk which, if not avoided, will result in death or serious injury.

Warning

1. The compatibility of the product is the responsibility of the person who designs the equipment or decides its specifications.

Since the product specified here is used under various operating conditions, its compatibility with specific equipment must be decided by the person who designs the equipment or decides its specifications based on necessary analysis and test results.

The expected performance and safety assurance of the equipment will be the responsibility of the person who has determined its compatibility with the product.

This person should also continuously review all specifications of the product referring to its latest catalog information, with a view to giving due consideration to any possibility of equipment failure when configuring the equipment.

2. Only personnel with appropriate training should operate machinery and equipment.

The product specified here may become unsafe if handled incorrectly.

The assembly, operation and maintenance of machines or equipment including our products must be performed by an operator who is appropriately trained and experienced.

3. Do not service or attempt to remove product and machinery/equipment until safety is confirmed.

1. The inspection and maintenance of machinery/equipment should only be performed after measures to prevent falling or runaway of the driven objects have been confirmed.

2. When the product is to be removed, confirm that the safety measures as mentioned above are implemented and the power from any appropriate source is cut, and read and understand the specific product precautions of all relevant products carefully.

3. Before machinery/equipment is restarted, take measures to prevent unexpected operation and malfunction.

4. Contact SMC beforehand and take special consideration of safety measures if the product is to be used in any of the following conditions.

1. Conditions and environments outside of the given specifications, or use outdoors or in a place exposed to direct sunlight.

2. Installation on equipment in conjunction with atomic energy, railways, air navigation, space, shipping, vehicles, military, medical treatment, combustion and recreation, or equipment in contact with food and beverages, emergency stop circuits, clutch and brake circuits in press applications, safety equipment or other applications unsuitable for the standard specifications described in the product catalog.

3. An application which could have negative effects on people, property, or animals requiring special safety analysis.

4. Use in an interlock circuit, which requires the provision of double interlock for possible failure by using a mechanical protective function, and periodical checks to confirm proper operation.



Safety Instructions

Caution

1. The product is provided for use in manufacturing industries.

The product herein described is basically provided for peaceful use in manufacturing industries.

If considering using the product in other industries, consult SMC beforehand and exchange specifications or a contract if necessary.

If anything is unclear, contact your nearest sales branch.

Limited warranty and Disclaimer/Compliance Requirements

The product used is subject to the following “Limited warranty and Disclaimer” and “Compliance Requirements”.

Read and accept them before using the product.

Limited warranty and Disclaimer

1. The warranty period of the product is 1 year in service or 1.5 years after the product is delivered, whichever is first.*2)

Also, the product may have specified durability, running distance or replacement parts. Please consult your nearest sales branch.

2. For any failure or damage reported within the warranty period which is clearly our responsibility, a replacement product or necessary parts will be provided.

This limited warranty applies only to our product independently, and not to any other damage incurred due to the failure of the product.

3. Prior to using SMC products, please read and understand the warranty terms and disclaimers noted in the specified catalog for the particular products.

***2) Vacuum pads are excluded from this 1 year warranty.**

A vacuum pad is a consumable part, so it is warranted for a year after it is delivered.

Also, even within the warranty period, the wear of a product due to the use of the vacuum pad or failure due to the deterioration of rubber material are not covered by the limited warranty.

Compliance Requirements

1. The use of SMC products with production equipment for the manufacture of weapons of mass destruction(WMD) or any other weapon is strictly prohibited.

2. The exports of SMC products or technology from one country to another are governed by the relevant security laws and regulation of the countries involved in the transaction. Prior to the shipment of a SMC product to another country, assure that all local rules governing that export are known and followed.

1. Product Specific Precautions 1



Precautions 1

Be sure to read before handling.

Design



Warning

•All models

1. The body material is A6063, the bellows is SUS316L, and other metal material is SUS304. The seal material for vacuum environment is FKM. The armature assembly for vacuum uses fluorine type resin (PFA). Use fluids those are compatible with using materials after confirming. A valve for vacuum environment uses vacuum grease (fluorine type grease:Y-VAC3).
2. If no control power is provided, apply starting voltage only for 0.15 to 0.2s. After that, be sure to apply holding voltage (25% of starting voltage). If this operation is neglected, it will cause coil burning and fire.
3. When starting voltage is applied, large current runs. Therefore, select a circuit component after checking the current on the specifications.
4. Be sure to place a fuse or an earth leakage breaker for a power supplying circuit.
5. Leakage current from a circuit should be 70mA or less. If the voltage between coil terminals becomes DC1V or more, the valve will not be closed.
6. Fluctuation of each voltage should be +/- 10% or less.

Selection



Caution

•All models

1. Use within the limits of the operating pressure range.

Mounting



Caution

• All models

1. In high humidity environments, keep the valve packed until the time of installation.
2. Perform piping so that excessive force is not applied to the flange sections. When there is vibration from heavy objects or attachments, etc., fix piping so that vibration will not apply torque directly to the flange section.

Piping



Caution

1. Before mounting, clean the surface of the flange seal and the O-ring with ethanol, etc.
2. There is an indentation of 0.1 to 0.2mm designed to protect the flange seal surface. Be careful when handling the product to prevent any damage to the seal surface .
3. If a control power supply is provided, DC specification has polarity. Follow the indication shown on the end of lead wire.
4. A wire for wiring should be 0.5 to 1.25mm² or more as reference.
5. Give enough curvature to the lead wire not to have excessive force when it is fixed.
6. Fluid containing foreign matters and oil will cause malfunction and sealing failure. Remove such things from the fluid.

 **Warning**

If the fluid or reaction product (deposit) may cause the valve to become unsafe, the valve should be disassembled, cleaned and re-assembled by an operator who has sufficient knowledge and experience (e.g. a specialist).

 **Caution**

1. When removing deposits from the valve, take care not to damage any part of the valve.
2. Replace the core assembly and the armature assembly when the end of its service.
Refer to Chapter 6, "Period and Scope of Warranty" (P. 10) for details regarding endurance cycles.
3. If potential damages are suspected prior to the end of the service life, perform maintenance earlier than noted.
4. SMC specified parts should be used for service. Refer to the Construction / Maintenance parts table.
5. When removing the external seal, take care not to damage the sealing surfaces. When installing the external seal, be sure that the O-ring is not twisted. (Refer to Chapter 7, "Parts Replacement Procedure" (P. 11 to 12) for details.)

2. Product Specific Precautions 2



Precautions 2 Be sure to read before handling

Maintenance Parts



Caution

SMC specified parts should be used for maintenance service.

Maintenance can be done without removing a pipe. Remove the four hexagon socket head cap screws on the top of the cover. When the sealant is replaced, be careful not to give a flaw on the sealing face such as a body.

When they are assembled again, the work can be done easily and accurately with the armature assembly absorbed to the core assembly. Check the operation and leakage after assembling.

Service parts See "Construction Drawing" for the construction number.

Construction no.	Description	XLS-16-□□	XLS-16-P□□	XLS-25-□□	XLS-25-P□□
(2)	Coil assembly	XLS16-20-*G,C,D,T	XLS16-20-P*G	XLS25-20-*G,C,D,T	XLS25-20-P*G
(6)	Core assembly	XLS16-30-1		XLS25-30-1	
(4)	Armature assembly	XLS16-30-2		XLS25-30-2	
(3-1)	Core O-ring	AS568-018V		AS568-018V	
(3-2)	Bonnet O-ring	AS568-025V		AS568-030V	

Note) Enter voltage no. at □□*□
G, C, D, and T after □* mean the symbol showing an electrical entry.

3. Specifications

Table 1 Valve specifications

Model		XLS-16	XLS-25	XLS-16-P*G	XLS-25-P*G
Flange (valve) size		16	25	16	25
Actuating type		Normally closed (N.C.)			
Fluid		Vacuum of inert gas			
Operating temperature °C		5 to 40			
Exhausting direction		Free			
Operating pressure Pa		1×10 ⁻⁶ (absolute pressure) to 0.1MPa (G)			
Conductance l/s Note 1		5	8	5	8
Leakage Pa·m ³ /s	Internal	1.3 x 10 ⁻⁸ at ambient temperatures , excluding gas permeation			
	External	1.3 x 10 ⁻¹¹ at ambient temperatures , excluding gas permeation			
Main material		Body: aluminum alloy, Bellows: SUS316L, Main part: SUS304, SUS405 equivalent, Seal: FKM and resin (PFA) Note 2			
Surface treatment for body		Outside: hard anodized Inside: basis material			
Control power supply		Not provided		Provided	
Operating power voltage (starting/ holding) V		DC24/6, DC48/12, DC100/24		DC24, AC100, AC200	
Allowable voltage fluctuation %		+/- 10			
Electrical entry		Type G, C, D, and T		Type G	
Type of coil isolation		Type B			
Max. operating frequency		10 cycle times/ min.			
Weight kg		0.4	0.7	0.7	1.0

Note 1 The conductance is “molecular flow” measured with an elbow pipe which has the same dimension with each flange.

Note 2 The valve for vacuum has vacuum grease (fluorine type: Y-VAC3).

Table 2 Power/ Current

With rated voltage applied

Model		Starting		Holding	
		Power(W)	Current(A)	Power(W)	Current(A)
XLS-16-	*G/C/D/T , P5G	36	1.5	4.8	0.38
	P1G	50Hz	30.5	14.8	0.35
		60Hz		10	0.27
	P2G	50Hz	30	0.24	4.9
60Hz				2.3	0.10
XLS-25-	*G/C/D/T , P5G	47	2.0	5.3	0.5
	P1G	50Hz	42	20	0.46
		60Hz		13.5	0.36
	P2G	50Hz	45	0.35	6.7
60Hz				3.0	0.12

4. Construction / Operation

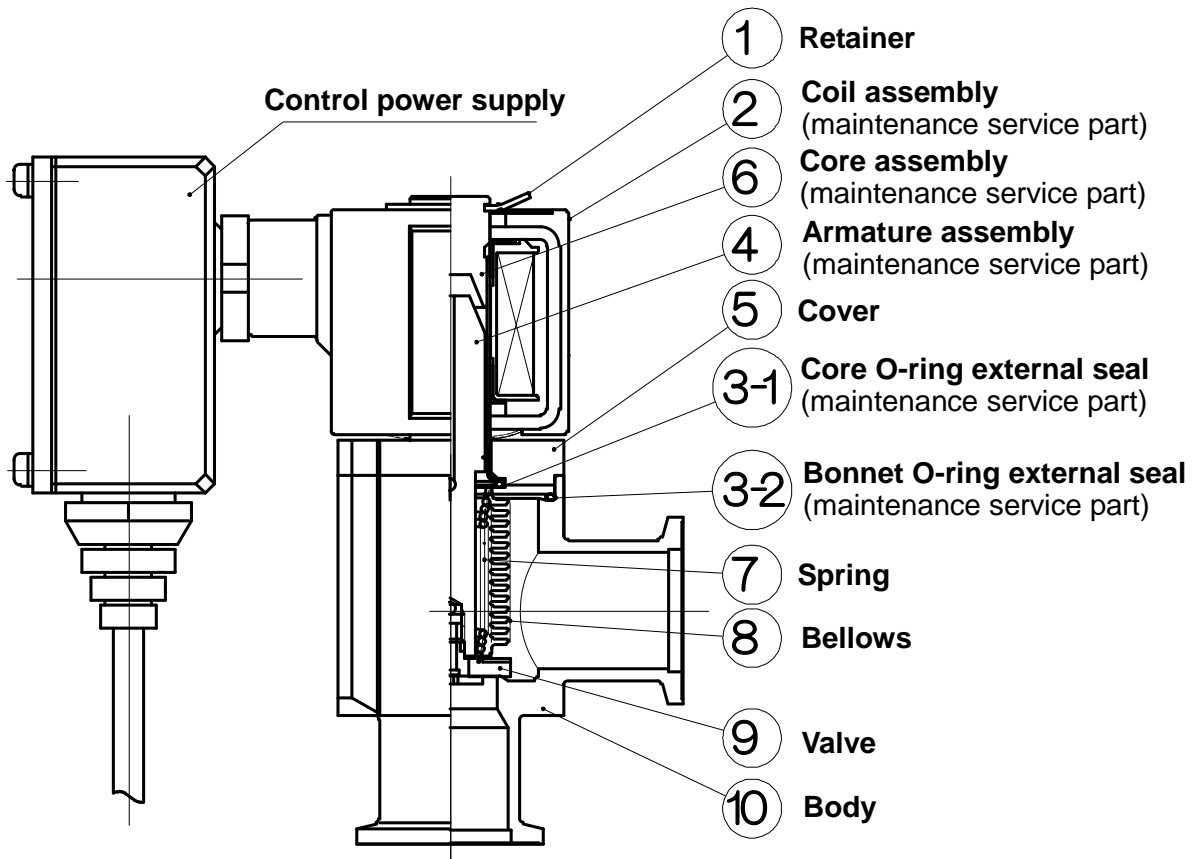

Armature assembly includes (7), (8), and (9).

<Operation Description>

4-1 XLS-**-** (without control power supply)

Valve (9) opens when the coil assembly is carrying starting voltage for approx. 0.15 to 0.2s.

The valve keeps opening with voltage by 25% of the starting voltage (see right). Do not apply the starting voltage for 0.3s or more. It will cause coil burning. When energizing to the coil assembly is stopped, valve (9) closes.

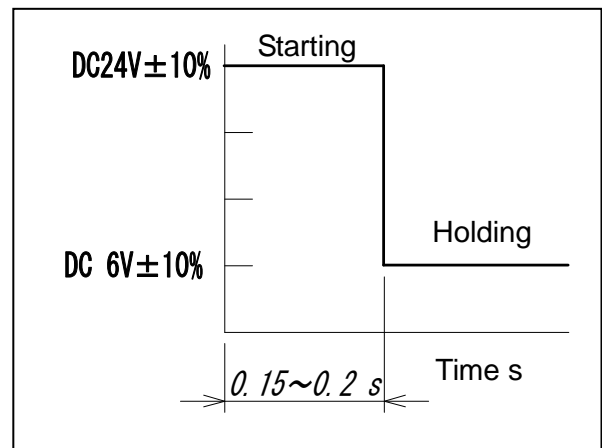

Ex.) For DC24. DC6 V specification,
The time to apply starting voltage is same for all voltage.

4-2 XLS-**-P*G (with control power supply)

Valve (9) opens when the coil assembly is applied the rated voltage.
Valve (9) closes when the coil assembly is stopped being energized.

As this product has pressure balanced construction, the exhausting direction is free.

5. Dimensions

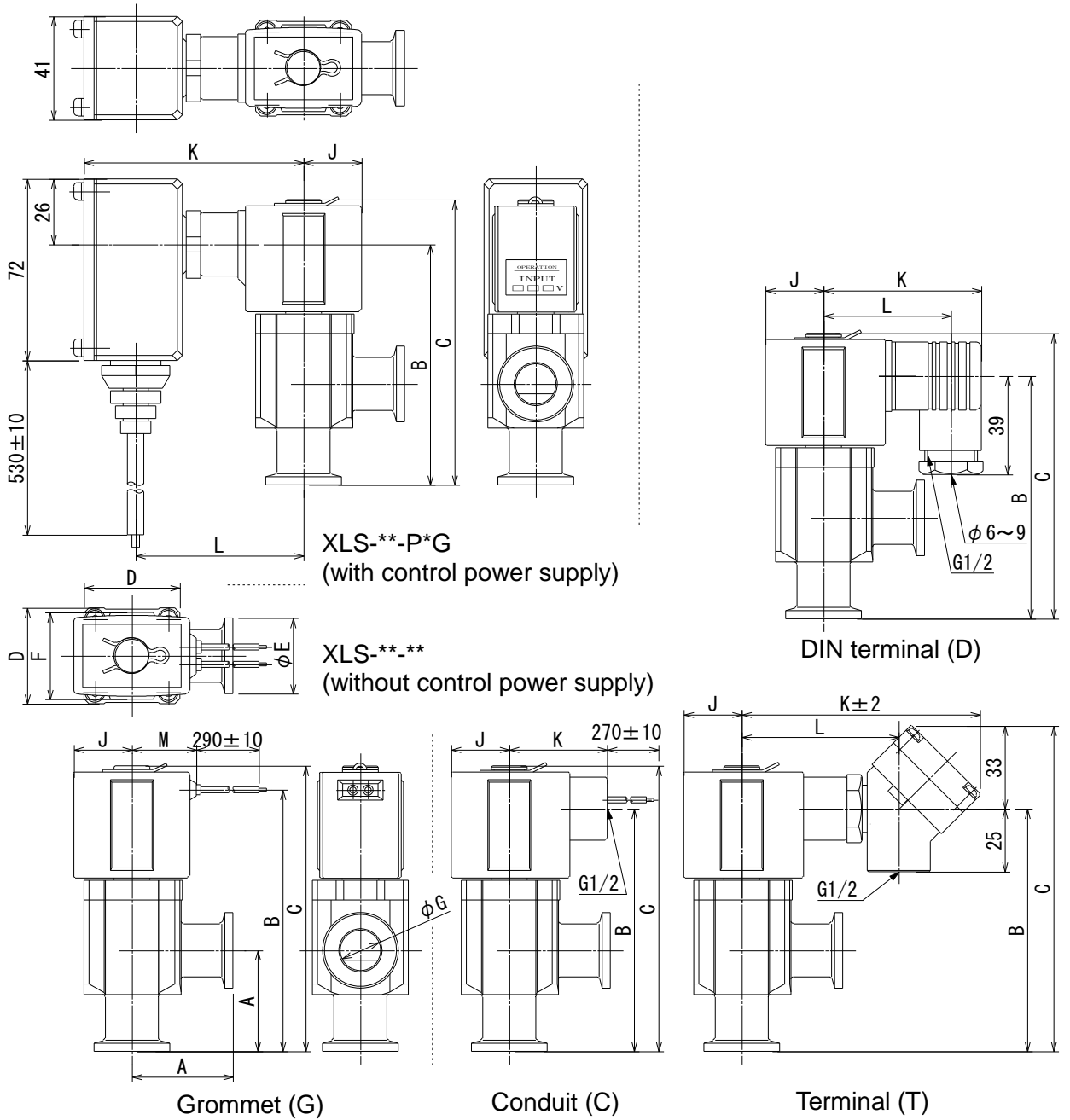

Model	mm										
	A	B	C	D	E	F	G	J	K	L	M
XLS-16-*G	40	104	113	38	30	35	17	23	-	-	25.5
XLS-16-*C		96							138.5	41	-
XLS-16-*D			60							48	-
XLS-16-*T		129	95						62	-	
XLS-25-*G	50	128.5	138.5	48	40	40	26	25.5	-	-	28
XLS-25-*C		120.5							154.5	43	-
XLS-25-*D			63							51	-
XLS-25-*T		121.5	97						66	-	
XLS-16-P*G	40	96	113	38	30	35	17	23	87	66.5	-
XLS-25-P*G	50	121.5	138.5	48	40	40	26	25.5	89.5	69	-

6.Period and Scope of Warranty

The warranty period is 0.5 million cycles (under SMC's endurance test conditions), 1 year in service or within 1.5 years after delivery, whichever comes first.

If the valve has been used outside of the specifications, or if a failure occurs as a result of mounting onto a machine or replacement of an assembly, seals, or etc. by the user, the warranty will not be applied.

Note) The endurance of the product will depend on the operating conditions (such as if the flow rate is large).

For any failure reported within the warranty period which is clearly our responsibility, the whole valve will be replaced. This guarantee does not apply to any damage incurred due to the failure of the valve.

Result of endurance test

(Using the circuit shown on the right)

The valve was opened and closed in an internal vacuum state at nominal (room) temperature and checked for internal and external leakage and proper operation.

We confirmed that the product satisfies the product specifications of 0.5 million cycles.

The test was performed with FKM, the standard sealant material.

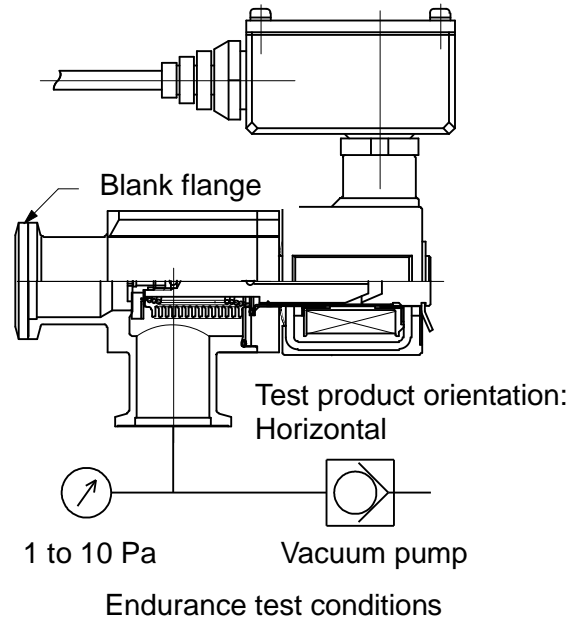

<Reference>

The pumping direction is not limited, but if the pumping creates a flow stream, the durability of the product could be impaired.

Therefore, the pumping direction shown on the right figure (bellows side pumping) is recommended. Also, the operating conditions should be checked prior to use, as this affects the life of the product.

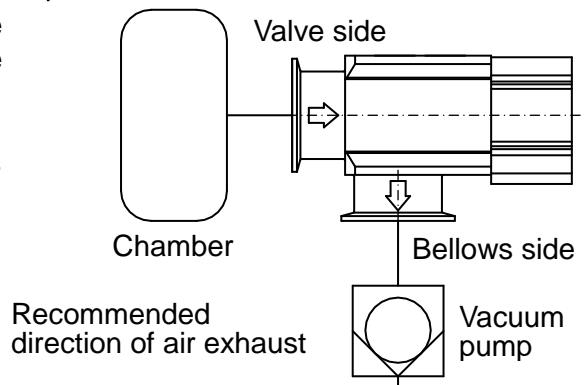

7.Parts Replacement Procedure

7-1. Precautions

Be sure to adhere to the instructions given in “1. Precautions 2”, when disassembling the product for maintenance. Along with the precautions listed in Chapter 2, the user should comply with those listed below.

Warning

- If it is expected that product materials may get stuck to the product, ensure safety is confirmed before handling. It is recommended that the user wear gloves and a mask.
- Pay attention to the handling of components in accordance with the procedures outlined, hereafter. Do not apply excessive force or impact. This may damage the product, as well as, decrease its performance and life expectancy.
- Do not disassemble the parts that are not explained in this operation manual. This may decrease the performance and life expectancy of these parts. In addition, disassembly may cause danger.
- **Torque values specified in this manual must be followed.** Not adhering to these specifications, can result in damage to the product.

7-2. Replacement Procedure

1: Replacement of coil assembly

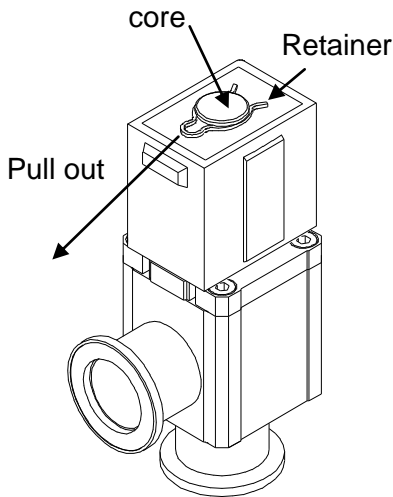

Pull out the retainer to the side with the coil assembly pressed downward.

Pull out the coil assembly from the body.

When it is assembled again, mount the retainer on the groove of the core securely.

2: Replacement of other parts Procedure 1

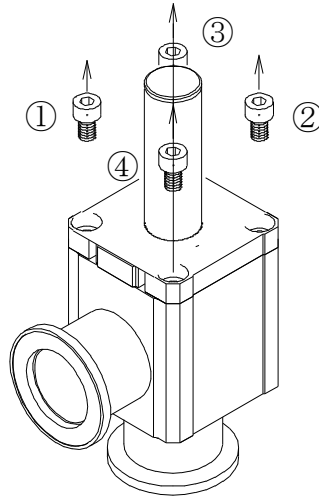

Loosen the bolts gradually in numerical order.

If the core assembly is not replaced, the coil assembly does not need to be removed in advance.

Procedure 2

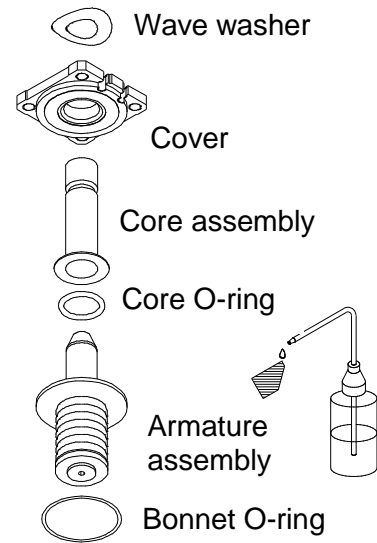

Parts excepting the wave washer and the cover are the service parts.

Replace a part which needs to be maintained. Wipe out dust on the surface of each part with a clean cloth (such as BENCOT) soaked into ethanol.

Procedure 3 Apply holding voltage

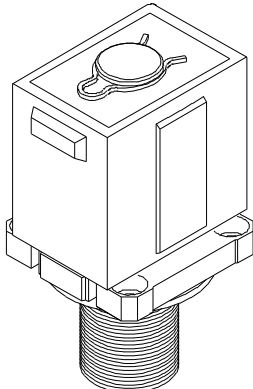

If the coil assembly is applied holding voltage with the above condition (Mount the core assembly on the cover, and fix the coil assembly with the retainer.

After that, press the armature assembly until the absorbing position.) when it is assembled again, the armature assembly is fixed at the absorbed position.

The procedure 4 can be done easily and accurately.

Procedure 4

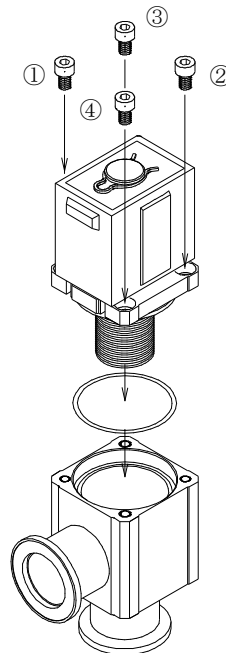

Tighten the bolts in numerical order without a flaw and dust on each part.

Procedure 5

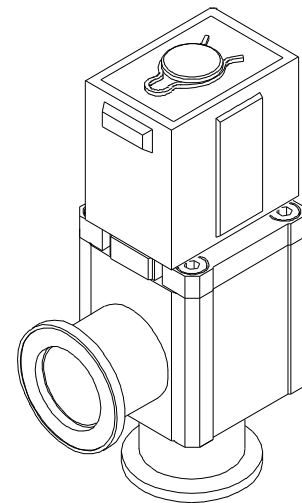

Check the operation and internal and external leakage.

Revision	
□ RENEWAL	2018.9

SMC Corporation

4-14-1, Sotokanda, Chiyoda-ku, Tokyo 101-0021 JAPAN

Tel: + 81 3 5207 8249 Fax: +81 3 5298 5362

URL <http://www.smcworld.com>

Note: Specifications are subject to change without prior notice and any obligation on the part of the manufacturer.
© 2011 SMC Corporation All Rights Reserved

XL*****-OMI0013-B