

# Compact Cylinder with Air Cushion

## RQ Series

ø20, ø25, ø32, ø40, ø50, ø63, ø80, ø100

Uses a unique air cushion mechanism with no cushion ring.

**New** A long stroke variant has been added to the air cushion cylinders.



Model	Mounting	Rod end configuration	Standard stroke : ●	Long stroke : ●	Auto switch												
R(D)Q□20	<ul style="list-style-type: none"> <li>•Through-hole</li> <li>•Double end tapped</li> <li>•Foot type</li> <li>•Rod side flange type</li> <li>•Head side flange type</li> <li>•Double clevis type</li> </ul>	<ul style="list-style-type: none"> <li>•Female thread</li> <li>•Male thread</li> </ul>	15	20	25	30	40	50	75	100	125	150	175	200	250	300	<ul style="list-style-type: none"> <li>•Direct mounting auto switch (ø20 to ø100)</li> </ul>
R(D)Q□25																	
R(D)Q□32																	
R(D)Q□40																	
R(D)Q□50																	
R(D)Q□63																	
R(D)Q□80																	
R(D)Q□100																	

\* Size ø20 and ø25 with standard strokes have through-holes and double end taps in common.  
 \* The through-hole option is not available for the long stroke variant.

# Future new standard for shock elimination,



Employs a new construction  
for the air cushion mechanism.



Compact Cylinder with Air Cushion

## RQ Series



## Unique air cushion construction with no cushion ring

Elimination of the cushion ring used in current cushion ring type air cushions has made it possible to reduce the overall length of the cylinder. This produces an air cushion cylinder which retains the merits of a compact design.

### Working principle

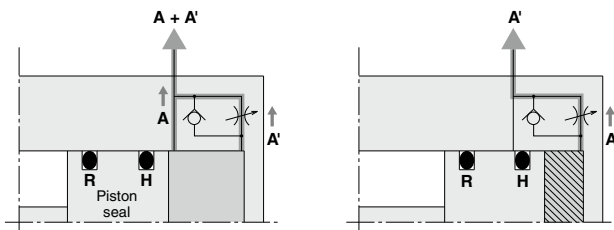

- ① When the piston is retracting, exhaust is discharged from both A and A' until piston seal H passes the air passage A.
- ② After piston seal H has passed the air passage A, exhaust is discharged only from A'. The section marked with diagonal lines becomes a cushion chamber, and a cushioning effect is achieved.
- ③ When air is supplied for piston extension, the check seal opens and the piston starts with no delay.

# noise reduction and improvement in repeatability

## Minimal extended dimensions from +2.5 mm to 13 mm

(Compared with series CDQS/CDQ2 of the same bore size with auto switches)

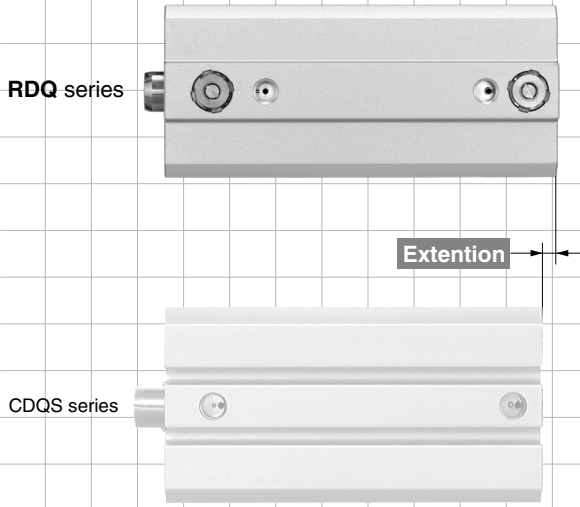

Series	Bore size	Extended dimension	Comparable cylinder
RDQ series	20	+2.5 mm	CDQS series
	25	+4 mm	
	32	+4 mm	
	40	+4.5 mm	CDQ2 series
	50	+9 mm	
	63	+9 mm	
	80	+10 mm	
100	+13 mm		

## Nearly three times the allowable kinetic energy

(Compared to the CQS/CQ2 series with rubber bumper)  
Improved energy absorption allows selection of a cylinder that is two sizes smaller for the same kinetic energy.

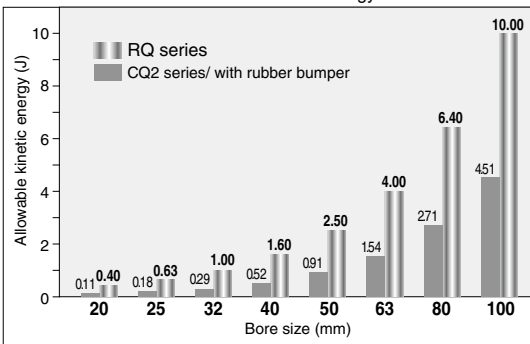

## Interchangeable mounting

The mounting dimension "M" is the same as the compact cylinder **CQS/CQ2** series.  
(CQS/CQ2 mounting brackets can be used without any changes.)

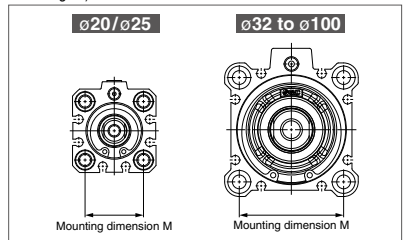

## Improved repeatability

The piston contact surface at the stroke end is metal, providing improved repeatability for the stopping position as compared with a rubber bumper.

## Improved noise reduction (Stroke end impact noise reduced)

- Decrease of 19dB or more (Compared with the **CQ2** series without cushion)
- Decrease of 14dB or more (Compared with the **CQ2** series with rubber bumper)

# Added compact type foot brackets

- Compact foot bracket has the same width as the cylinder. Overall width reduced by up to **42%** (for  $\phi 20$ )

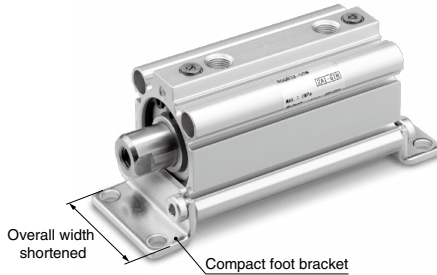

## ■ More compact installation space possible

- Short pitch mounting is possible. ● Allows installation close against a wall.

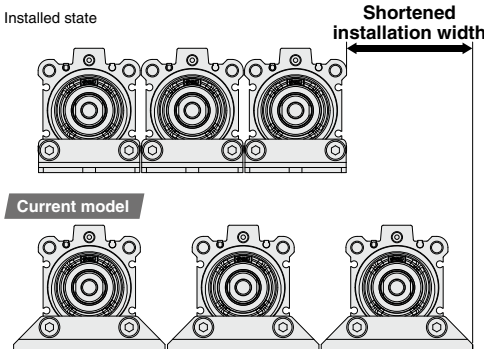

Bore size (mm)	Compact foot type width A (mm)	Current foot type width B (mm)	Reduced width for short pitch mounting (mm)		
			1 unit	2 units	3 units
20	36	62	26	52	78
25	40	66	26	52	78
32	45	71	26	52	78
40	52	78	26	52	78
50	64	95	31	62	93
63	77	113	36	72	108
80	98	140	42	84	126
100	117	162	45	90	135

\* Short pitch mounting is possible only without auto switch.

## ■ Height from the bottom of brackets to the center of a cylinder is the same as the current model.

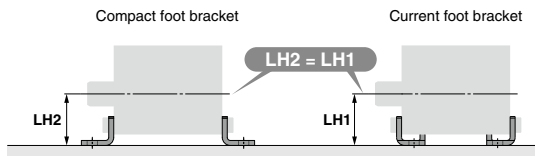

# Compact Cylinder with Air Cushion

# RQ Series

ø20, ø25, ø32, ø40, ø50, ø63, ø80, ø100

## How to Order

Without auto switch

RQ B 32 □ - 50 □ - □

With auto switch

RDQ B 32 □ - 50 □ - M9BW □ - □

With auto switch magnet

1 2 3 4 5 6 7 8

### 1 Mounting bracket

<b>B</b>	Through-hole (Standard)
<b>A</b>	Both ends tapped type
<b>L</b>	Foot type
<b>LC</b>	Compact foot type
<b>F</b>	Rod side flange type
<b>G</b>	Head side flange type
<b>D</b>	Double clevis type

Note 1) Mounting brackets are packed together when shipped (unassembled).

Note 2) Since sizes ø20 and ø25 have a body with type B (Through-hole) and type A (Both ends tapped type) in common, there is no type A part number. Example) RQA 20-30 does not exist.

Note 3) A through-hole type mounting bolt is available as an option. For details ⇒ p. 1041

### 2 Bore size

<b>20</b>	20 mm
<b>25</b>	25 mm
<b>32</b>	32 mm
<b>40</b>	40 mm
<b>50</b>	50 mm
<b>63</b>	63 mm
<b>80</b>	80 mm
<b>100</b>	100 mm

### 3 Thread type

<b>Nil</b>	M thread	ø20, 25
	Rc	
<b>TN</b>	NPT	ø32 to 100
	G	

### 6 Auto switch

<b>Nil</b>	Without auto switch
------------	---------------------

\* Refer to the table below for the applicable auto switch model.

### 5 Body option

<b>Nil</b>	Standard (Rod end female thread)
<b>M</b>	Rod end male thread

### 8 Made to order common specifications

For details ⇒ p. 1040

### 4 Cylinder stroke (mm)

Bore size	Standard stroke
<b>20, 25</b>	15, 20, 25, 30, 40, 50
<b>32, 40</b>	20, 25, 30, 40, 50, 75, 100
<b>50, 63</b>	30, 40, 50, 75, 100
<b>80, 100</b>	40, 50, 75, 100

\* For long strokes exceeding the standard stroke range ⇒ p. 1053-3

\* For details on the manufacturing of intermediate strokes ⇒ p. 1040

### 7 Number of auto switches

<b>Nil</b>	2
<b>S</b>	1
<b>n</b>	n

## Built-in Magnet Cylinder Model

If a built-in magnet cylinder without an auto switch is required, there is no need to enter the symbol for the auto switch. (Example) RDQL40-50

## Applicable Auto Switches/Refer to pages 1271 to 1365 for further information on auto switches.

Type	Special function	Electrical entry	Indicator light	Wiring (Output)	Load voltage		Auto switch model		Lead wire length (m)				Pre-wired connector	Applicable load		
					DC	AC	Perpendicular	In-line	0.5 (Nil)	1 (M)	3 (L)	5 (Z)			None (N)	
Solid state auto switch	—	Grommet	—	3-wire (NPN)	24 V	5 V, 12 V	—	M9NV	M9N	●	●	○	—	○	IC circuit	
				3-wire (PNP)				M9PV	M9P	●	●	○	—	○		
				2-wire				M9BV	M9B	●	●	○	—	○		—
				3-wire (NPN)				M9NWV	M9NW	●	●	○	—	○		IC circuit
	3-wire (PNP)	M9PWW	M9PW	●	●	○	—	○								
	Diagnostic indicator (2-color indicator)	Grommet	Yes	2-wire	24 V	12 V	—	M9BWW	M9BW	●	●	○	—	○	—	
				3-wire (NPN)				M9NAV*1	M9NA*1	○	○	●	—	○		IC circuit
	Water resistance (2-color indicator)	Grommet	—	3-wire (PNP)	24 V	5 V, 12 V	—	M9PAV*1	M9PA*1	○	○	●	—	○	—	
				2-wire				M9BAV*1	M9BA*1	○	○	●	—	○		
	Magnetic field resistant (2-color indicator)	Grommet	—	2-wire (Non-polar)	24 V	—	—	—	P3DWA**	●	—	●	—	○	—	
3-wire (NPN equiv.)				A96V				A96	●	—	●	—	—	○		IC circuit
Reed auto switch	—	Grommet	Yes	2-wire	24 V	5 V, 12 V	100 V or less	A93V*2	A93	●	●	●	●	—	Relay, PLC	
								A90V	A90	●	—	●	—	—		—

\*1 Water resistant type auto switches can be mounted on the above models, but in such case SMC cannot guarantee water resistance.

\*2 1 m type lead wire is only applicable to D-A93.

\* Lead wire length symbols: 0.5 m..... Nil (Example) M9NV  
1 m..... M (Example) M9NVM  
3 m..... L (Example) M9NLW  
5 m..... Z (Example) M9NZW  
None..... N (Example) J79CN

\* Solid state auto switches marked with a "○" are produced upon receipt of order.

\*\* The D-P3DWA□ is mountable on bore size ø25 to ø100.

\* Besides the models in the above catalog, there are some other auto switches that are applicable. For more information, refer to page 1056.

\* Refer to pages 1340 and 1341 for the details of auto switches with a pre-wired connector.

\* When mounting brackets (foot/flange type) are used, then in some cases auto switches cannot be retrofitted.

# RQ Series



**Symbol**  
Air cushion

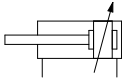

Symbol	Specifications
-XA □	Change of Rod End Shape
-XC4	With heavy duty scraper
-XC35	With coil scraper (For ø32 to 100 only)

## Allowable kinetic energy

Refer to "Selection" on page 1057 regarding the allowable kinetic energy.

## Effective Cushion Length

Bore size (mm)	20	25	32	40	50	63	80	100
Effective cushion length (mm)	5.8	6.1	6.6	6.6	7.1	7	7.5	8

## Mounting Bracket Part No.

Bore size (mm)	Foot <sup>Note 1)</sup>	Compact foot	Flange	Double clevis
20	CQS-L020	CQS-LC020	CQS-F020	CQS-D020
25	CQS-L025	CQS-LC025	CQS-F025	CQS-D025
32	CQ-L032	CQ-LC032	CQ-F032	CQ-D032
40	CQ-L040	CQ-LC040	CQ-F040	CQ-D040
50	CQ-L050	CQ-LC050	CQ-F050	CQ-D050
63	CQ-L063	CQ-LC063	CQ-F063	CQ-D063
80	CQ-L080	CQ-LC080	CQ-F080	CQ-D080
100	CQ-L100	CQ-LC100	CQ-F100	CQ-D100

Note 1) When ordering foot/compact foot brackets, order 2 pieces per cylinder.

Note 2) The following parts are included with each bracket.  
Foot/Compact foot/Flange : Body mounting bolts.  
Double clevis: Clevis pins, type C retaining ring for axis, and Body mounting bolts.

## Specifications

Bore size (mm)	20	25	32	40	50	63	80	100
Lubrication	Not required (non-lube)							
Fluid	Air							
Proof pressure	1.5 MPa							
Maximum operating pressure	1.0 MPa							
Minimum operating pressure	0.05 MPa							
Ambient and fluid temperature	Without auto switch magnet : -10 to 70°C (No freezing) With auto switch magnet : -10 to 60°C							
Rod end thread	Female thread							
Stroke length tolerance	+1.0 0							
Mounting	Through-hole							
Piston speed	50 to 500 mm/s							

## Standard Stroke

Bore size (mm)	Standard stroke (mm)
20, 25	15, 20, 25, 30, 40, 50
32, 40	20, 25, 30, 40, 50, 75, 100
50, 63	30, 40, 50, 75, 100
80, 100	40, 50, 75, 100

## Manufacture of Intermediate Stroke

Description	Exclusive body	
Part no.	Refer to "How to Order" for standard model	
Method	Available in stroke increments of 1mm, using an exclusive body for the specified stroke.	
Stroke range	Bore size	Stroke range
	20, 25	16 to 49
	32, 40	21 to 99
	50, 63	31 to 99
Example	80, 100	41 to 99
	Part no.: RQB32-47 A special tube is manufactured for a 47mm stroke.	

## Theoretical Output

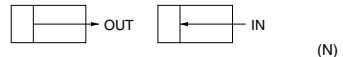

Bore size (mm)	Operating direction	Operating pressure (MPa)		
		0.3	0.5	0.7
20	IN	71	118	165
	OUT	94	157	220
25	IN	113	189	264
	OUT	147	245	344
32	IN	181	302	422
	OUT	241	402	563
40	IN	317	528	739
	OUT	377	628	880
50	IN	495	825	1150
	OUT	589	982	1370
63	IN	841	1400	1960
	OUT	935	1560	2180
80	IN	1360	2270	3170
	OUT	1510	2510	3520
100	IN	2140	3570	5000
	OUT	2360	3930	5500

## Weight

### Basic Weight

(g)

Bore size (mm)	Standard stroke (mm)							
	15	20	25	30	40	50	75	100
20	135	149	163	177	205	233	—	—
25	190	207	224	241	275	309	—	—
32	—	244	264	283	323	362	461	559
40	—	355	377	399	443	487	597	707
50	—	—	—	665	731	797	962	1127
63	—	—	—	873	948	1022	1208	1393
80	—	—	—	—	1660	1778	2073	2368
100	—	—	—	—	2777	2937	3335	3734

### Additional Weight

(g)

Bore size (mm)	20	25	32	40	50	63	80	100	
Magnet	5	6	11	13	14	22	24	35	
Both ends tapped type	—	—	6	6	6	19	45	45	
Rod end male thread	Male thread		6	12	26	27	53	120	175
	Nut		4	8	17	17	32	32	49
Foot type (including bolt)	159	181	143	155	243	324	696	1062	
Compact foot type (including bolt)	97	116	99	114	177	241	501	770	
Rod side flange type (including bolt)	143	180	180	214	373	559	1056	1365	
Head side flange type (including bolt)	137	171	165	198	348	534	1017	1309	
Double clevis type (including pin, retaining ring and bolt)	92	127	151	196	393	554	1109	1887	

#### Calculation example) RQD32-20M

- Basic weight : RQB32-20 244 g
- Additional weight : Double end tapped 6 g
- Rod end male thread 43 g
- Double clevis 151 g
- 444 g

## Mounting Bolts for R(D)QB

Through-hole type mounting bolts for R(D)QB are available.  
Refer to the following for ordering procedures.  
Order the actual number of bolts that will be used.

**Example) CQ-M5x50L 4 pcs.**

Material: Chromium molybdenum steel  
Surface treatment: Zinc chromated

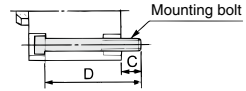

Cylinder model	C	D	Mounting bolt Part no.
<b>R(D)QB20-15</b>	9	50	CQ-M5 x 50L
-20		55	x 55L
-25		60	x 60L
-30		65	x 65L
-40		75	x 75L
-50		85	x 85L
<b>R(D)QB25-15</b>	9.5	55	CQ-M5 x 55L
-20		60	x 60L
-25		65	x 65L
-30		70	x 70L
-40		80	x 80L
-50		90	x 90L
<b>R(D)QB32-20</b>	10	60	CQ-M5 x 60L
-25		65	x 65L
-30		70	x 70L
-40		80	x 80L
-50		90	x 90L
-75		115	x 115L
-100	140	x 140L	

Cylinder model	C	D	Mounting bolt Part no.	
<b>R(D)QB40-20</b>	8	65	CQ-M5 x 65L	
-25		70	x 70L	
-30		75	x 75L	
-40		85	x 85L	
-50		95	x 95L	
-75		120	x 120L	
-100	145	x 145L		
<b>R(D)QB50-30</b>	13.5	85	CQ-M6 x 85L	
-40		95	x 95L	
-50		105	x 105L	
-75		130	x 130L	
-100		155	x 155L	
<b>R(D)QB63-30</b>		15.5	90	CQ-M8 x 90L
-40	100		x 100L	
-50	110		x 110L	
-75	135		x 135L	
-100	160		x 160L	
<b>R(D)QB80-40</b>	15		105	CQ-M10 x 105L
-50		115	x 115L	
-75		140	x 140L	
-100		165	x 165L	
<b>R(D)QB100-40</b>		17.5	120	CQ-M10 x 120L
-50			130	x 130L
-75	155		x 155L	
-100	180		x 180L	

# RQ Series

## Construction

ø20 to ø40

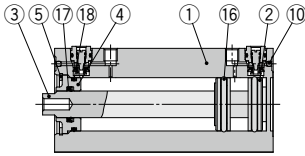

With auto switch (Built-in magnet)

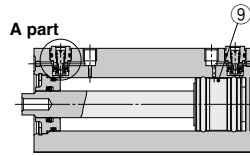

ø50 to ø100

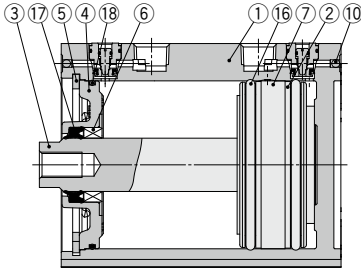

With auto switch (Built-in magnet)

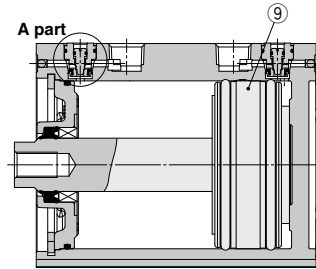

M: Rod end male thread

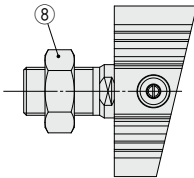

Details of A part

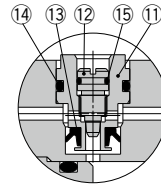

## Component Parts

No.	Description	Material	Note
1	Cylinder tube	Aluminum alloy	Hard anodized
2	Piston	Aluminum alloy	
3	Piston rod	Stainless steel	ø20, ø25
		Carbon steel	ø32 to ø100, Hard chrome plated
4	Collar	Aluminum alloy	ø20 to ø40, Anodized
		Aluminum alloy casted	ø50 to ø100, Chromated, Painted
5	Retaining ring	Carbon tool steel	Phosphate coating
6	Bushing	Bearing alloy	ø50 to ø100
7	Wear ring	Resin	ø63 to ø100
8	Rod end nut	Carbon steel	Zinc chromated
9	Magnet	—	
10	Steel ball	High carbon chrome bearing steel	
11	Check seal retainer	Brass	Electroless nickel plated
12	Cushion needle	Stainless steel	
13	Check seal	NBR	
14	Check gasket	NBR	
15	Needle gasket	NBR	
16	Piston seal	NBR	
17	Rod seal	NBR	
18	Tube gasket	NBR	

## Replacement Parts/Seal Kit

Bore size (mm)	Part no.	Contents
20	RQB20-PS	Set of nos. above ⑬, ⑰, ⑱, and a grease pack (GR-S-010)
25	RQB25-PS	
32	RQB32-PS	
40	RQB40-PS	
50	RQB50-PS	
63	RQB63-PS	
80	RQB80-PS	
100	RQB100-PS	

\* Seal kit includes ⑱, ⑰ and ⑱. Order the seal kit, based on each bore size.

\* The seal kit includes a grease pack.  
Order with the following part number when only the grease pack is needed.

Grease pack part number: GR-S-010 (10 g), GR-S-020 (20 g), GR-S-400 (400 g)

The dimensions remain the same regardless of the selection of a magnet in the "How to order" section.  
 \* For the auto switch mounting position and its mounting height, refer to pages 1054 and 1055.

## Dimensions: $\varnothing 20$ , $\varnothing 25$

### Basic type (Through-hole/Both ends tapped common): RQB/RDQB

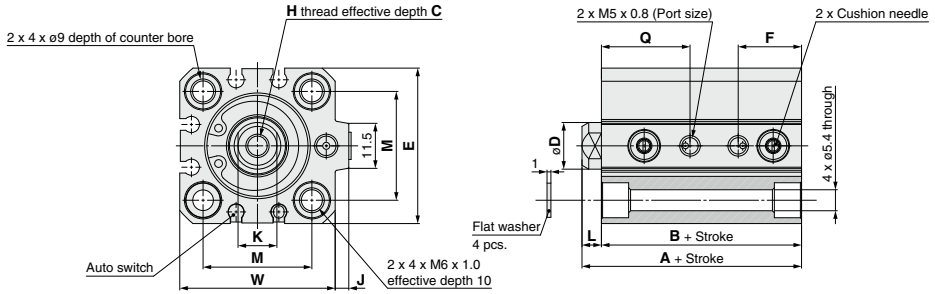

Bore size (mm)	Stroke range (mm)	A	B	C	D	E	F	H	J	K	L	M	Q	W
20	15 to 50	36.5	32	7	10	36	15.5	M5 x 0.8	3	8	4.5	25.5	21	39
25	15 to 50	41.5	36.5	12	12	40	17	M6 x 1.0	3.5	10	5	28	23	43.5

\* Refer to page 1052 for details on rod end nut and accessories.

- Add the stroke to calculate the length of intermediate strokes.

### Rod end male thread

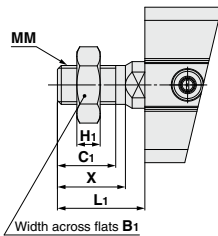

Bore size (mm)	B <sub>1</sub>	H <sub>1</sub>	C <sub>1</sub>	X	MM	L <sub>1</sub>
20	13	5	12	14	M8 x 1.25	18.5
25	17	6	15	17.5	M10 x 1.25	22.5

# RQ Series

## Mounting Bracket Dimensions

The dimensions remain the same regardless of the selection of a magnet in the "How to order" section.

### Foot type: RQL/RDQL

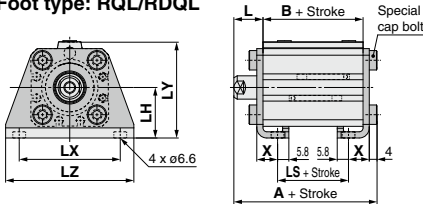

#### Rod end male thread

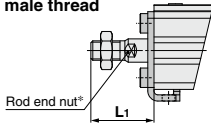

### Compact foot type: RQLC/RDQLC

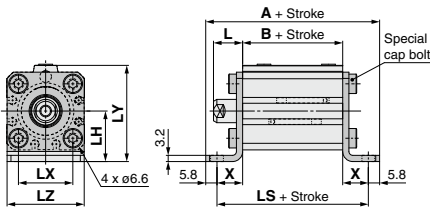

#### Rod end male thread

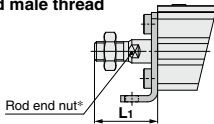

### Rod side flange type: RQF/RDQF

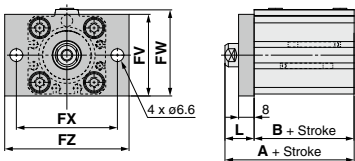

#### Rod end male thread

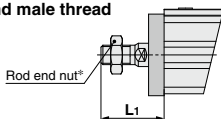

### Foot Type

Bore size (mm)	Stroke range (mm)	A	B	LS	L
20	15 to 50	53.7	32	20	14.5
25	15 to 50	58.7	36.5	21.5	15

Bore size (mm)	L1	LH	LX	LY	LZ	X
20	28.5	24	48	45	62	9.2
25	32.5	26	52	49.5	66	10.7

Foot bracket material: Carbon steel  
Surface treatment: Nickel plated

### Compact Foot Type

Bore size (mm)	Stroke range (mm)	A	B	LS	L
20	15 to 50	70	32	58.4	14.5
25	15 to 50	74.5	36.5	62.9	15

Bore size (mm)	L1	LH	LX	LY	LZ	X
20	28.5	24	25.5	45	36	13.2
25	32.5	26	28	49.5	40	13.2

Foot bracket material: Carbon steel  
Surface treatment: Zinc chromated

### Rod Side Flange Type

Bore size (mm)	Stroke range (mm)	A	B	L
20	15 to 50	46.5	32	14.5
25	15 to 50	51.5	36.5	15

Bore size (mm)	L1	FV	FW	FX	FZ
20	28.5	39	40.5	48	60
25	32.5	42	44.5	52	64

Flange material: Carbon steel  
Surface treatment: Nickel plated

## Mounting Bracket Dimensions

The dimensions remain the same regardless of the selection of a magnet in the "How to order" section.

### Head side flange type: RQG/RDQG

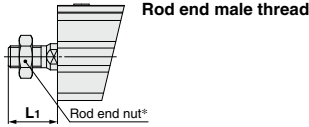
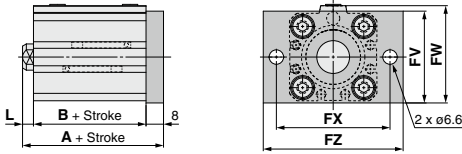

### Head Side Flange Type

Bore size (mm)	Stroke range (mm)	A	L	L <sub>1</sub>	mm
20	15 to 50	44.5	4.5	18.5	
25	15 to 50	49.5	5	22.5	

\* All dimensions but A, L and L<sub>1</sub> are identical to those of the rod side flange type.

Flange material: Carbon steel  
Surface treatment: Nickel plated

### Double clevis type: RQD/RDQD

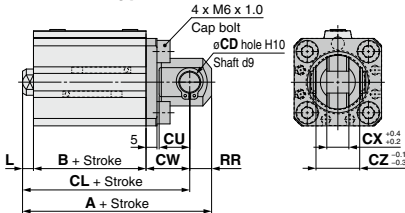

### Double Clevis Type

Bore size (mm)	Stroke range (mm)	A	B	CL	CD	CU	mm
20	15 to 50	63.5	32	54.5	8	12	
25	15 to 50	71.5	36.5	61.5	10	14	

Bore size (mm)	CW	CX	CZ	L	L <sub>1</sub>	RR	mm
20	18	8	16	4.5	18.5	9	
25	20	10	20	5	22.5	10	

\* Double clevis pins and retaining rings are included in the package.

\* Refer to page 1052 for details on rod end nut and accessories.

Double clevis bracket material: Carbon steel  
Surface treatment: Nickel plated

# RQ Series

The dimensions remain the same regardless of the selection of a magnet in the "How to order" section.  
 \* For the auto switch mounting position and its mounting height, refer to pages 1054 and 1055.

## Dimensions: $\varnothing 32$ , $\varnothing 40$ , $\varnothing 50$

### Basic type (Through-hole): RQB/RDQB

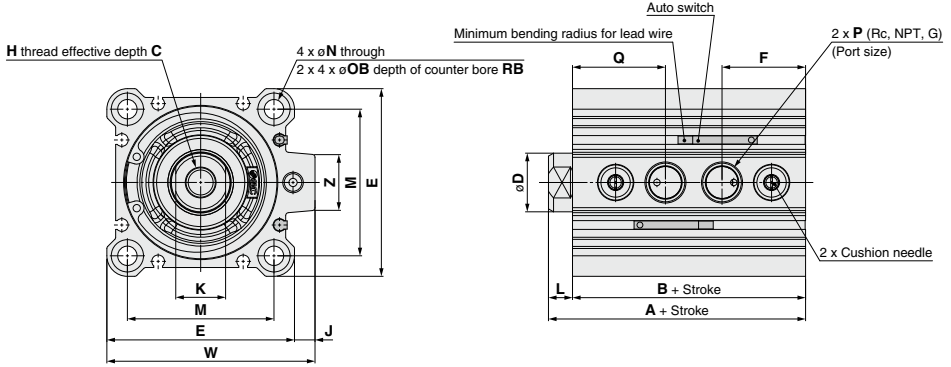

Bore size (mm)	Stroke range (mm)	A	B	C	D	E	F	H	J	K	L	M	N
32	20 to 100	44	37	13	16	45	18.5	M8 x 1.25	4.5	14	7	34	5.5
40	20 to 100	51	44	13	16	52	20	M8 x 1.25	5	14	7	40	5.5
50	30 to 100	57.5	49.5	15	20	64	28.5	M10 x 1.5	7	17	8	50	6.6

Bore size (mm)	OB	P	Q	RB	W	Z
32	9	1/8	23	7	49.5	14
40	9	1/8	28	7	57	15
50	11	1/4	31.5	8	71	19

\* Refer to page 1052 for details on rod end nut and accessories.

• Add the stroke to calculate the length of intermediate strokes.

### Both ends tapped type: RQA/RDQA

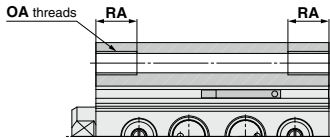

Bore size (mm)	OA	RA
32	M6 x 1.0	10
40	M6 x 1.0	10
50	M8 x 1.25	14

### Rod end male thread

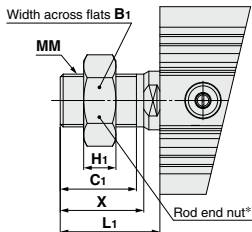

Bore size (mm)	B <sub>1</sub>	H <sub>1</sub>	C <sub>1</sub>	X	MM	L <sub>1</sub>
32	22	8	20.5	23.5	M14 x 1.5	28.5
40	22	8	20.5	23.5	M14 x 1.5	28.5
50	27	11	26	28.5	M18 x 1.5	33.5

## Mounting Bracket Dimensions

The dimensions remain the same regardless of the selection of a magnet in the "How to order" section.

### Foot type: RQL/RDQL

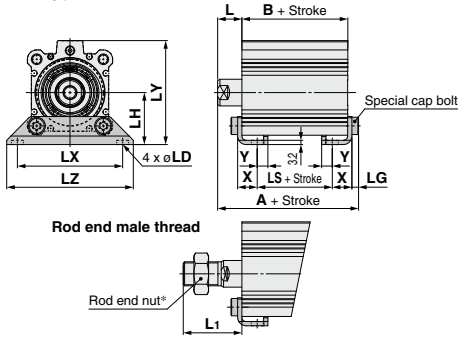

### Foot Type

Bore size (mm)	Stroke range (mm)	A	B	LS	L	L1	LD
32	20 to 100	61.2	37	21	17	38.5	6.6
40	20 to 100	68.2	44	28	17	38.5	6.6
50	30 to 100	75.7	49.5	26.5	18	43.5	9

Bore size (mm)	LG	LH	LX	LY	LZ	X	Y
32	4	30	57	57	71	11.2	5.8
40	4	33	64	64	78	11.2	7
50	5	39	79	78	95	14.7	8

Foot bracket material: Carbon steel  
Surface treatment: Nickel plated

### Compact foot type: RQLC/RDQLC

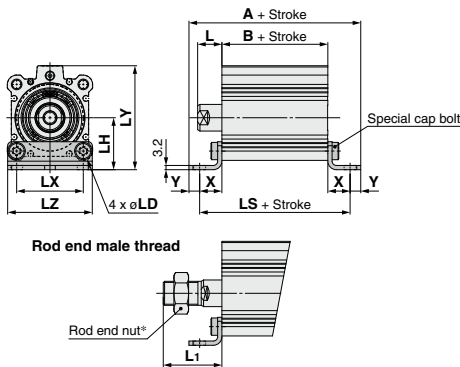

### Compact Foot Type

Bore size (mm)	Stroke range (mm)	A	B	LS	L	L1	LD
32	20 to 100	76	37	64.4	17	38.5	6.6
40	20 to 100	85.4	44	71.4	17	38.5	6.6
50	30 to 100	98.9	49.5	82.9	18	43.5	9

Bore size (mm)	LH	LX	LY	LZ	X	Y
32	30	34	57	45	13.7	5.8
40	33	40	64	52	13.7	7
50	39	50	78	64	16.7	8

Foot bracket material: Carbon steel  
Surface treatment: Zinc chromated

### Rod side flange type: RQF/RDQF

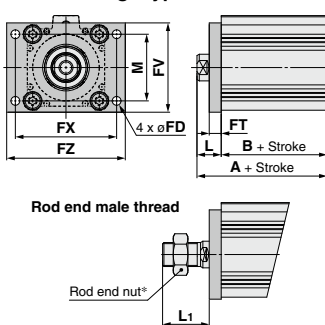

### Rod Side Flange Type

Bore size (mm)	Stroke range (mm)	A	B	FD	FT	FV
32	20 to 100	54	37	5.5	8	48
40	20 to 100	61	44	5.5	8	54
50	30 to 100	67.5	49.5	6.6	9	67

Bore size (mm)	FX	FZ	L	L1	M
32	56	65	17	38.5	34
40	62	72	17	38.5	40
50	76	89	18	43.5	50

Flange bracket material: Carbon steel  
Surface treatment: Nickel plated

## Mounting Bracket Dimensions

The dimensions remain the same regardless of the selection of a magnet in the "How to order" section.

### Head side flange type: RQG/RDQG

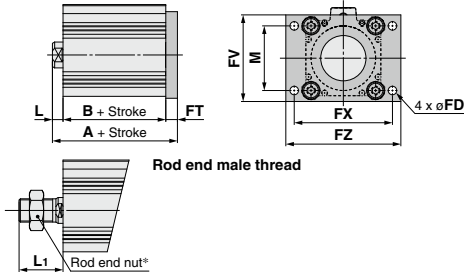

### Head Side Flange Type

Bore size (mm)	Stroke range (mm)	A	L	L1
32	20 to 100	52	7	28.5
40	20 to 100	59	7	28.5
50	30 to 100	66.5	8	33.5

\* All dimensions but A, L and L1 are identical to those of the rod side flange type. Flange bracket material: Carbon steel  
Surface treatment: Nickel plated

### Double clevis type: RQD/RDQD

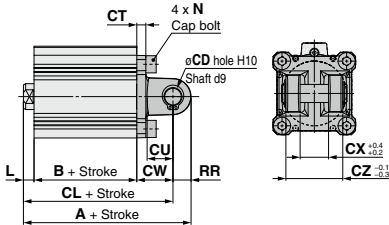

### Double Clevis Type

Bore size (mm)	Stroke range (mm)	A	B	CL	CD	CT	CU
32	20 to 100	74	37	64	10	5	14
40	20 to 100	83	44	73	10	6	14
50	30 to 100	99.5	49.5	85.5	14	7	20

Bore size (mm)	CW	CX	CZ	L	L1	N	RR
32	20	18	36	7	28.5	M6 x 1.0	10
40	22	18	36	7	28.5	M6 x 1.0	10
50	28	22	44	8	33.5	M8 x 1.25	14

\* Double clevis pins and retaining rings are included in the package. Double clevis bracket material: Cast iron  
Surface treatment: Painted  
\* Refer to page 1052 for details on rod end nut and accessories.

The dimensions remain the same regardless of the selection of a magnet in the "How to order" section.  
 \* For the auto switch mounting position and its mounting height, refer to pages 1054 and 1055.

## Dimensions: $\varnothing 63$ , $\varnothing 80$ , $\varnothing 100$

### Basic type (Through-hole)

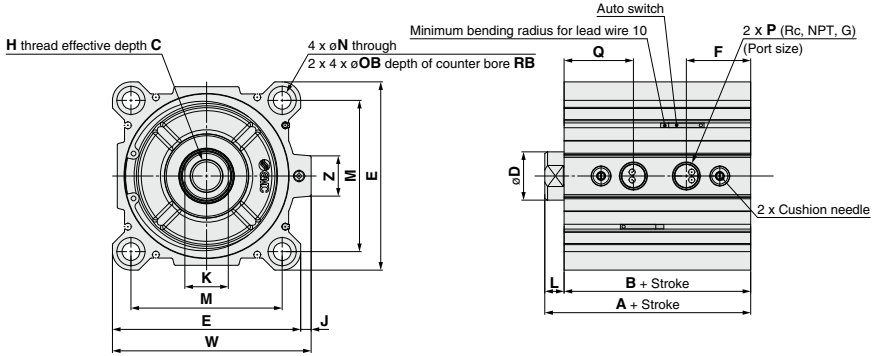

Bore size (mm)	Stroke range (mm)	A	B	C	D	E	F	H	J	K	L	M	N	OB	P
63	30 to 100	63	55	15	20	77	31	M10 x 1.5	7	17	8	60	9	14	1/4
80	40 to 100	73.5	63.5	21	25	98	35.5	M16 x 2.0	6	22	10	77	11	17.5	3/8
100	40 to 100	88	76	27	30	117	40	M20 x 2.5	6.5	27	12	94	11	17.5	3/8

Bore size (mm)	Q	RB	W	Z
63	34	10.5	84	19
80	39	13.5	104	25
100	43	13.5	123.5	25

\* Refer to page 1052 for details on rod end nut and accessories.

• Add the stroke to calculate the length of intermediate strokes.

### Both ends tapped type: RQA/RDQA

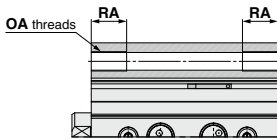

Bore size (mm)	OA	RA
63	M10 x 1.5	18
80	M12 x 1.75	22
100	M12 x 1.75	22

### Rod end male thread

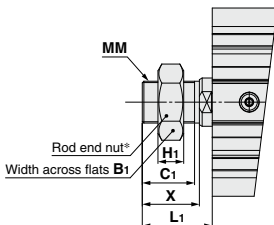

Bore size (mm)	B <sub>1</sub>	H <sub>1</sub>	C <sub>1</sub>	X	MM	L <sub>1</sub>
63	27	11	26	28.5	M18 x 1.5	33.5
80	32	13	32.5	35.5	M22 x 1.5	43.5
100	41	16	32.5	35.5	M26 x 1.5	43.5

# RQ Series

## Mounting Bracket Dimensions

The dimensions remain the same regardless of the selection of a magnet in the "How to order" section.

### Foot type: RQL/RDQL

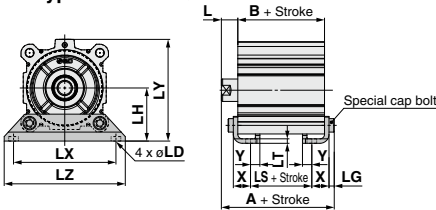

Rod end male thread

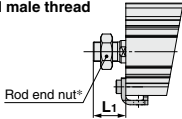

### Foot Type

Bore size (mm)	Stroke range (mm)	A	B	LS	L	L1	LD	LG	LH	LT	mm
63	30 to 100	81.2	55	29	18	43.5	11	5	46	3.2	
80	40 to 100	95	63.5	33.5	20	53.5	13	7	59	4.5	
100	40 to 100	111	76	42	22	53.5	13	7	71	6	

Bore size (mm)	LX	LY	LZ	X	Y
63	95	91.5	113	16.2	9
80	118	114	140	19.5	11
100	137	136	162	23	12.5

Foot bracket material: Carbon steel  
Surface treatment: Nickel plated

### Compact foot type: RQLC/RDQLC

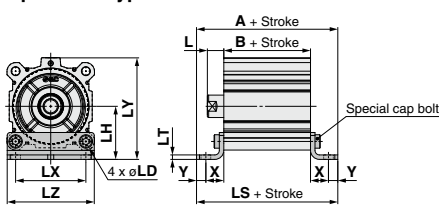

Rod end male thread

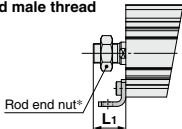

### Compact Foot Type

Bore size (mm)	Stroke range (mm)	A	B	LS	L	L1	LD	LH	LT	mm
63	30 to 100	109.4	55	91.4	18	43.5	11	46	3.2	
80	40 to 100	130.5	63.5	108.5	20	53.5	13	59	4.5	
100	40 to 100	149	76	124	22	53.5	13	71	6	

Bore size (mm)	LX	LY	LZ	X	Y
63	60	91.5	77	18.2	9
80	77	114	98	22.5	11
100	94	136	117	24	12.5

Foot bracket material: Carbon steel  
Surface treatment: Zinc chromated

### Rod side flange type: RQF/RDQF

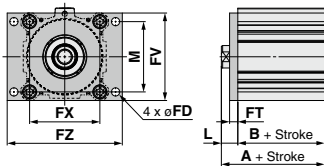

Rod end male thread

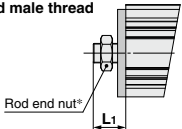

### Rod Side Flange Type

Bore size (mm)	Stroke range (mm)	A	B	FD	FT	FV	FX	FZ	L	L1	M	mm
63	30 to 100	73	55	9	9	80	92	108	18	43.5	60	
80	40 to 100	83.5	63.5	11	11	99	116	134	20	53.5	77	
100	40 to 100	98	76	11	11	117	136	154	22	53.5	94	

Flange bracket material: Carbon steel  
Surface treatment: Nickel plated

## Mounting Bracket Dimensions

The dimensions remain the same regardless of the selection of a magnet in the "How to order" section.

### Head side flange type: RQG/RDQG

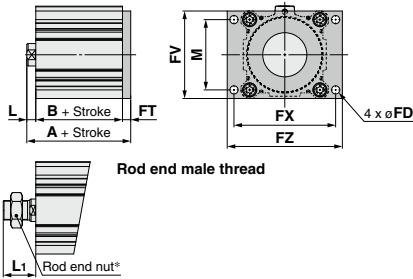

### Head Side Flange Type

Bore size (mm)	Stroke range (mm)	A	L	L <sub>1</sub>
63	30 to 100	72	8	33.5
80	40 to 100	84.5	10	43.5
100	40 to 100	99	12	43.5

\* All dimensions but A, L and L<sub>1</sub> are identical to those of the rod side flange type. Flange bracket material: Carbon steel  
Surface treatment: Nickel plated

### Double clevis type: RQD/RDQD

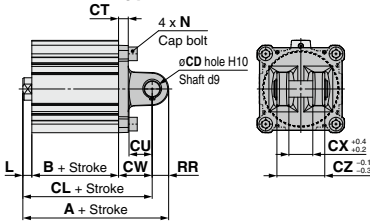

### Double Clevis Type

Bore size (mm)	Stroke range (mm)	A	B	CL	CD	CT	CU	CW	CX	CZ	L
63	30 to 100	107	55	93	14	8	20	30	22	44	8
80	40 to 100	129.5	63.5	111.5	18	10	27	38	28	56	10
100	40 to 100	155	76	133	22	13	31	45	32	64	12

Bore size (mm)	L <sub>1</sub>	N	RR
63	33.5	M10 x 1.5	14
80	43.5	M12 x 1.75	18
100	43.5	M12 x 1.75	22

\* Double clevis pins and retaining rings are included in the package.  
\* Refer to page 1052 for details on rod end nut and accessories.

Double clevis bracket material: Cast iron  
Surface treatment: Painted

# Accessory Bracket Dimensions

## Single Knuckle Joint

For I-G02, I-G03

For I-G04, I-G05  
I-G08, I-G10

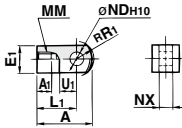

Material: Carbon steel  
Surface treatment: Nickel plated

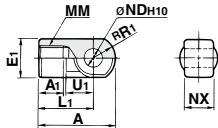

Material: Cast iron  
Surface treatment: Nickel plated

## Double Knuckle Joint

For Y-G02, Y-G03

For Y-G04, Y-G05  
Y-G08, Y-G10

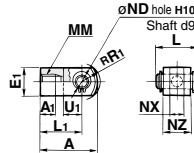

Material: Carbon steel  
Surface treatment: Nickel plated

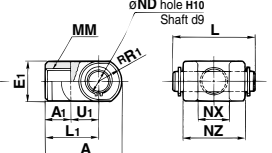

Material: Cast iron  
Surface treatment: Nickel plated

Part no.	Applicable bore size (mm)	A	A1	E1	L1	MM	R <sub>R1</sub>	U1	ND	NX
I-G02	20	34	8.5	□16	25	M8 x 1.25	10.3	11.5	8 <sup>+0.058</sup> <sub>0</sub>	8 <sup>-0.2</sup> <sub>-0.4</sub>
I-G03	25	41	10.5	□20	30	M10 x 1.25	12.8	14	10 <sup>+0.058</sup> <sub>0</sub>	10 <sup>-0.2</sup> <sub>-0.4</sub>
I-G04	32, 40	42	14	ø22	30	M14 x 1.5	12	14	10 <sup>+0.058</sup> <sub>0</sub>	18 <sup>-0.3</sup> <sub>-0.5</sub>
I-G05	50, 63	56	18	ø28	40	M18 x 1.5	16	20	14 <sup>+0.070</sup> <sub>0</sub>	22 <sup>-0.3</sup> <sub>-0.5</sub>
I-G08	80	71	21	ø38	50	M22 x 1.5	21	27	18 <sup>+0.070</sup> <sub>0</sub>	28 <sup>-0.3</sup> <sub>-0.5</sub>
I-G10	100	79	21	ø44	55	M26 x 1.5	24	31	22 <sup>+0.084</sup> <sub>0</sub>	32 <sup>-0.3</sup> <sub>-0.5</sub>

Part no.	Applicable bore size (mm)	A	A1	E1	L1	MM	R <sub>R1</sub>	U1	ND	NX	NZ	L	Applicable pin no.
Y-G02	20	34	8.5	□16	25	M8 x 1.25	10.3	11.5	8 <sup>+0.058</sup> <sub>0</sub>	8 <sup>-0.4</sup> <sub>-0.2</sub>	16	21	IY-G02
Y-G03	25	41	10.5	□20	30	M10 x 1.25	12.8	14	10 <sup>+0.058</sup> <sub>0</sub>	10 <sup>-0.2</sup> <sub>-0.4</sub>	20	23	IY-G03
Y-G04	32, 40	42	16	ø22	30	M14 x 1.5	12	14	10 <sup>+0.058</sup> <sub>0</sub>	18 <sup>-0.3</sup> <sub>-0.5</sub>	36	41	IY-G04
Y-G05	50, 63	56	20	ø28	40	M18 x 1.5	16	20	14 <sup>+0.070</sup> <sub>0</sub>	22 <sup>-0.3</sup> <sub>-0.5</sub>	44	51	IY-G05
Y-G08	80	71	23	ø38	50	M22 x 1.5	21	27	18 <sup>+0.070</sup> <sub>0</sub>	28 <sup>-0.3</sup> <sub>-0.5</sub>	56	64	IY-G08
Y-G10	100	79	24	ø44	55	M26 x 1.5	24	31	22 <sup>+0.084</sup> <sub>0</sub>	32 <sup>-0.3</sup> <sub>-0.5</sub>	64	72	IY-G10

\* Knuckle pin and retaining ring are included.

## Knuckle Pin (Common with double clevis pin)

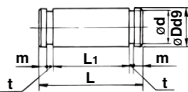

Material: Carbon steel  
mm

Part no.	Applicable bore size (mm)	D	L	d	L1	m	t	Retaining ring
IY-G02	20	8 <sup>-0.040</sup> <sub>-0.076</sub>	21	7.6	16.2	1.5	0.9	C8 type for pivot
IY-G03	25	10 <sup>-0.040</sup> <sub>-0.076</sub>	25.6	9.6	20.2	1.55	1.15	C10 type for pivot
IY-G04	32, 40	10 <sup>-0.040</sup> <sub>-0.076</sub>	41.6	9.6	36.2	1.55	1.15	C10 type for pivot
IY-G05	50, 63	14 <sup>-0.050</sup> <sub>-0.093</sub>	50.6	13.4	44.2	2.05	1.15	C14 type for pivot
IY-G08	80	18 <sup>-0.050</sup> <sub>-0.093</sub>	64	17	56.2	2.55	1.35	C18 type for pivot
IY-G10	100	22 <sup>-0.065</sup> <sub>-0.117</sub>	72	21	64.2	2.55	1.35	C22 type for pivot

\* Type C retaining rings for axis are included.

## Rod End Nut

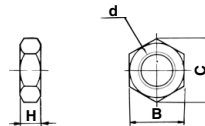

Material: Carbon steel  
Surface treatment: Zinc chromated  
mm

Part no.	Applicable bore size (mm)	d	H	B	C
NT-02	20	M8 x 1.25	5	13	15.0
NT-03	25	M10 x 1.25	6	17	19.6
NT-04	32, 40	M14 x 1.5	8	22	25.4
NT-05	50, 63	M18 x 1.5	11	27	31.2
NT-08	80	M22 x 1.5	13	32	37.0
NT-10	100	M26 x 1.5	16	41	47.3

## Simple Joint (RQ): $\phi 20$ to $\phi 100$

### Joint/Mounting Bracket (Type A/B) Part Nos.

Bore size (mm)	Joint	Type A mounting bracket	Type B mounting bracket
20	YU-020	YA-020	YB-020
25	YU-025	YA-025	YB-025
32, 40	YU-03	YA-03	YB-03
50, 63	YU-05	YA-05	YB-05
80	YU-08	YA-08	YB-08
100	YU-10	YA-10	YB-10

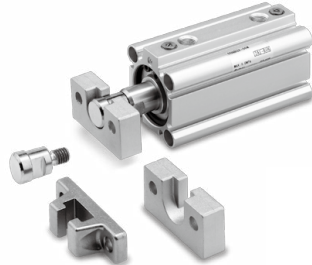

<Ordering>

- Joints are not included with type A or B mounting brackets. Order them separately.

(Example)

- Bore size  $\phi 40$  Part no.
- Type A mounting bracket ..... YA-03
- Joint ..... YU-03

### Allowable Eccentricity

(mm)

Bore size (mm)	20	25	32	40	50	63	80	100
Eccentricity tolerance	$\pm 0.5$			$\pm 1$			$\pm 1.5$	$\pm 2$
Axial direction backlash				0.5				

### Type A Mounting Bracket

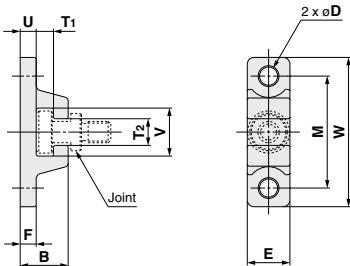

Material: Chromium molybdenum steel (Nickel plating) (mm)

Bore size (mm)	Part no.	B	D	E	F	M	T <sub>1</sub>	T <sub>2</sub>
20	YA-020	12	4.5	13	5	30	3.5	6
25	YA-025	12.5	5.5	15	5	33	3.5	7
32, 40	YA-03	18	6.8	16	6	42	6.5	10
50, 63	YA-05	20	9	20	8	50	6.5	12
80	YA-08	26	11	25	10	62	8.5	16
100	YA-10	31	14	30	12	76	10.5	18

Bore size (mm)	Part no.	U	V	W	Weight (g)
20	YA-020	5	13.5	42	27
25	YA-025	5	16.5	45	34
32, 40	YA-03	6	18	56	55
50, 63	YA-05	8	22	67	100
80	YA-08	10	28	83	195
100	YA-10	12	36	100	340

### Type B Mounting Bracket

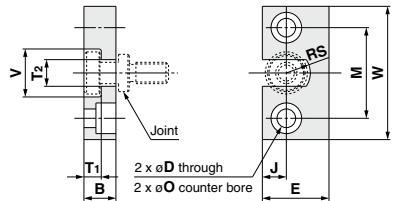

Material: Stainless steel (mm)

Bore size (mm)	Part no.	B	D	E	J	M	O
20	YB-020	7	4.5	18	7	25.5	—
25	YB-025	7.5	5.5	20	8	28	—
32, 40	YB-03	12	7	25	9	34	11.5 depth 7.5
50, 63	YB-05	12	9	32	11	42	14.5 depth 8.5
80	YB-08	16	11	38	13	52	18 depth 12
100	YB-10	19	14	50	17	62	21 depth 14

Bore size (mm)	Part no.	T <sub>1</sub>	T <sub>2</sub>	V	W	RS	Weight (g)
20	YB-020	3.5	6	13.6	36	3	28
25	YB-025	3.5	7	16.6	40	3.5	36
32, 40	YB-03	6.5	10	18	50	9	80
50, 63	YB-05	6.5	12	22	60	11	120
80	YB-08	8.5	16	28	75	14	230
100	YB-10	10.5	18	36	90	18	455

# RQ Series

## Joint

YU-020, YU-025

YU-03, YU-05  
YU-08, YU-10

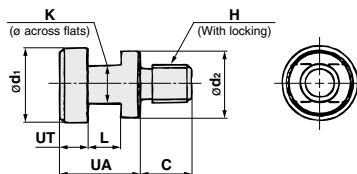
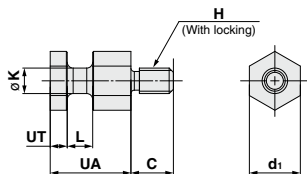

Material: Chromium molybdenum steel (Nickel plating)

Applicable bore size (mm)	Part no.	UA	C	$d_1$	$d_2$	H	K	L	UT	Weight (g)
20	YU-020	11.5	6	10	—	M5 x 0.8	5	4	3	7
25	YU-025	12	11	12	—	M6 x 1.0	6	4.5	3	10
32, 40	YU-03	17	11	15.8	14	M8 x 1.25	8	7	6	25
50, 63	YU-05	17	13	19.8	18	M10 x 1.5	10	7	6	40
80	YU-08	22	20	24.8	23	M16 x 2	13	9	8	90
100	YU-10	26	26	29.8	28	M20 x 2.5	14	11	10	160

# Compact Cylinder with Air Cushion Long Stroke Type

## RQ Series

ø20, ø25, ø32, ø40, ø50, ø63, ø80, ø100

### How to Order

Without auto switch

RQ **A** **32** **□** - **300** **C** **□**

With auto switch

RDQ **A** **32** **□** - **300** **C** **□** - **M9BW** **□**

With auto switch magnet

① ② ③ ④ ⑤ ⑥ ⑦ ⑧

#### ① Mounting bracket

<b>A</b>	Through-hole (Standard)
<b>L</b>	Foot type
<b>LC</b>	Compact foot type
<b>F</b>	Rod side flange type
<b>G</b>	Head side flange type
<b>D</b>	Double clevis type

\* Mounting brackets are packed together when shipped (unassembled).

#### ② Bore size

<b>20</b>	20 mm
<b>25</b>	25 mm
<b>32</b>	32 mm
<b>40</b>	40 mm
<b>50</b>	50 mm
<b>63</b>	63 mm
<b>80</b>	80 mm
<b>100</b>	100 mm

#### ③ Thread type

<b>Nil</b>	M thread	ø20, 25
	Rc	
<b>TF</b>	NPT	ø32 to 100
	G	

#### ⑤ Cushion

<b>C</b>	With rubber bumper
----------	--------------------

#### ④ Cylinder stroke (mm)

Bore size	Standard stroke
<b>20, 25</b>	75, 100, 125, 150, 175, 200
<b>32, 40, 50, 63, 80, 100</b>	125, 150, 175, 200, 250, 300

\* For details on the manufacturing of intermediate strokes → p. 1053-3

#### ⑥ Body option

<b>Nil</b>	Standard (Rod end female thread)
<b>M</b>	Rod end male thread

### Built-in Magnet Cylinder Model

If a built-in magnet cylinder without an auto switch is required, there is no need to enter the symbol for the auto switch.  
(Example) RDQA40-200C

#### ⑦ Auto switch

<b>Nil</b>	Without auto switch
------------	---------------------

\* Refer to the table below for the applicable auto switch model.

#### ⑧ Number of auto switches

<b>Nil</b>	2
<b>S</b>	1
<b>n</b>	n

### Applicable Auto Switches/Refer to pages 1271 to 1365 for further information on auto switches.

Type	Special function	Electrical entry	Indicator/light	Wiring (Output)	Load voltage		Auto switch model		Lead wire length (m)					Pre-wired connector	Applicable load									
					DC	AC	Perpendicular	In-line	0.5 (Nil)	1 (M)	3 (L)	5 (Z)	None (N)		IC circuit	Relay, PLC								
Solid state auto switch	—	Grommet	—	3-wire (NPN)	24 V	5 V, 12 V	—	<b>M9NV</b>	<b>M9N</b>	●	●	○	—	—	○	IC circuit	Relay, PLC							
				3-wire (PNP)				<b>M9PV</b>	<b>M9P</b>	●	●	○	—	—	○									
				2-wire				<b>M9BV</b>	<b>M9B</b>	●	●	○	—	—	○			—						
	Diagnostic indicator (2-color indicator)	Grommet	Yes	3-wire (NPN)	24 V	5 V, 12 V	—	<b>M9NWV</b>	<b>M9NW</b>	●	●	○	—	—	○	IC circuit	Relay, PLC							
				3-wire (PNP)				<b>M9PWV</b>	<b>M9PW</b>	●	●	○	—	—	○									
				2-wire				<b>M9BWW</b>	<b>M9BW</b>	●	●	○	—	—	○			—						
Water resistance (2-color indicator)	Grommet	—	3-wire (NPN)	24 V	5 V, 12 V	—	<b>M9NAV</b> *1	<b>M9NA</b> *1	○	○	●	—	—	○	IC circuit	Relay, PLC								
			3-wire (PNP)				<b>M9PAV</b> *1	<b>M9PA</b> *1	○	○	●	—	—	○										
			2-wire				<b>M9BAV</b> *1	<b>M9BA</b> *1	○	○	●	—	—	○			—							
Magnetic field resistant (2-color indicator)	Grommet	—	2-wire (Non-polar)	24 V	5 V, 12 V	100 V or less	—	<b>P3DWA</b> **	●	—	●	—	—	○	IC circuit	Relay, PLC								
			Reed auto switch				Grommet	Yes	3-wire (NPN equiv.)	—	5 V	—	<b>A96V</b>	<b>A96</b>			●	—	●	—	—	—	IC circuit	—
									2-wire	24 V	12 V	100 V	<b>A93V</b> *2	<b>A93</b>			●	●	●	●	—	—	—	—
		No		2-wire	24 V	5 V, 12 V	100 V or less	<b>A90V</b>	<b>A90</b>	●	—	●	—	—	—	—	IC circuit	—						

\*1 Water resistant type auto switches can be mounted on the above models, but in such case SMC cannot guarantee water resistance.

\*2 1 m type lead wire is only applicable to D-A93.

\* Lead wire length symbols: 0.5 m..... Nil (Example) M9NV  
1 m..... M (Example) M9NWM  
3 m..... L (Example) M9NWL  
5 m..... Z (Example) M9NZ  
None..... N (Example) J79CN

\* Solid state auto switches marked with a "○" are produced upon receipt of order.

\*\* The D-P3DWA□ is mountable on bore size ø25 to ø100.

\* Besides the models in the above catalog, there are some other auto switches that are applicable. For more information, refer to page 1056.

\* Refer to pages 1340 and 1341 for the details of auto switches with a pre-wired connector.

\* When mounting brackets (foot/flange type) are used, then in some cases auto switches cannot be retrofitted.

# RQ Series



**Symbol**  
Air cushion

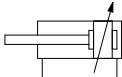

## Allowable kinetic energy

Refer to "Selection" on page 1057 regarding the allowable kinetic energy.

## Effective Cushion Length

Bore size (mm)	20	25	32	40	50	63	80	100
Effective cushion length (mm)	5.8	6.1	6.6	6.6	7.1	7	7.5	8

## Mounting Bracket Part No.

Bore size (mm)	Note 1) Foot	Compact foot	Flange	Double clevis
20	CQS-L020	CQS-LC020	CQS-F020	CQS-D020
25	CQS-L025	CQS-LC025	CQS-F025	CQS-D025
32	CQ-L032	CQ-LC032	CQ-F032	CQ-D032
40	CQ-L040	CQ-LC040	CQ-F040	CQ-D040
50	CQ-L050	CQ-LC050	CQ-F050	CQ-D050
63	CQ-L063	CQ-LC063	CQ-F063	CQ-D063
80	CQ-L080	CQ-LC080	CQ-F080	CQ-D080
100	CQ-L100	CQ-LC100	CQ-F100	CQ-D100

Note 1) When ordering foot/compact foot brackets, order 2 pieces per cylinder.

Note 2) The following parts are included with each bracket.

Foot/Compact foot/Flange : Body mounting bolts.

Double clevis: Clevis pins, type C retaining ring for axis, and Body mounting bolts.

## Specifications

Bore size (mm)	20	25	32	40	50	63	80	100
Lubrication	Not required (non-lube)							
Fluid	Air							
Proof pressure	1.5 MPa							
Maximum operating pressure	1.0 MPa							
Minimum operating pressure	0.05 MPa							
Ambient and fluid temperature	Without auto switch magnet : -10 to 70°C With auto switch magnet : -10 to 60°C (No freezing)							
Stroke length tolerance	+1.4 (Note) 0							
Cushion	Air cushion, Rubber bumper							
Piston speed	50 to 500 mm/s							

Note) The stroke length tolerance does not include the tolerance of the bumper.

## Standard Stroke

Bore size (mm)	Standard stroke (mm)
20, 25	75, 100, 125, 150, 175, 200
32, 40, 50, 63, 80, 100	125, 150, 175, 200, 250, 300

## Manufacture of Intermediate Stroke

Description	Exclusive body	
Part no.	Refer to "How to Order" for standard model	
Method	Available in stroke increments of 1mm, using an exclusive body for the specified stroke.	
Stroke range	Bore size	Stroke range
	20, 25	51 to 199
	32, 40, 50, 63, 80, 100	101 to 299
Example	Part no.: RQA32-115DC A special tube is manufactured for a 115 mm stroke.	

## Theoretical Output

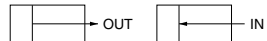

(N)

Bore size (mm)	Operating direction	Operating pressure (MPa)		
		0.3	0.5	0.7
20	IN	71	118	165
	OUT	94	157	220
25	IN	113	189	264
	OUT	147	245	344
32	IN	181	302	422
	OUT	241	402	563
40	IN	317	528	739
	OUT	377	628	880
50	IN	495	825	1150
	OUT	589	982	1370
63	IN	841	1400	1960
	OUT	935	1560	2180
80	IN	1360	2270	3170
	OUT	1510	2510	3520
100	IN	2140	3570	5000
	OUT	2360	3930	5500

## Weight

### Basic Weight

Bore size (mm)	Standard stroke (mm)							
	75	100	125	150	175	200	250	300
20	348	418	488	558	627	697	—	—
25	451	536	622	707	793	878	—	—
32	—	—	726	824	922	1019	1214	1409
40	—	—	925	1036	1146	1256	1476	1697
50	—	—	1442	1607	1772	1936	2266	2596
63	—	—	1737	1923	2108	2294	2665	3036
80	—	—	3008	3302	3597	3892	4481	5071
100	—	—	4560	4958	5357	5755	6553	7350

### Additional Weight

Bore size (mm)		20	25	32	40	50	63	80	100
Magnet		5	6	11	13	14	22	24	35
Rod end male thread	Male thread	6	12	26	27	53	53	120	175
	Nut	4	8	17	17	32	32	49	116
Foot type (including bolt)		159	181	143	155	243	324	696	1062
Compact foot type (including bolt)		97	116	99	114	177	241	501	770
Rod side flange type (including bolt)		137	171	165	198	348	534	1017	1309
Head side flange type (including bolt)		137	171	165	198	348	534	1017	1309
Double clevis type (including pin, retaining ring and bolt)		92	127	151	196	393	554	1109	1887

Calculation example) **RDQF32-200CM**

- Basic weight: RQA32-200C 1019 g
- Additional weight: Magnet 11 g
- Rod end male thread 43 g
- Rod side flange type 165 g
- 1238 g

# RQ Series

## Construction

ø20, ø25

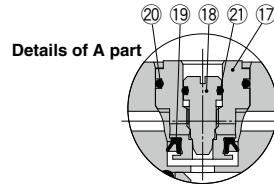
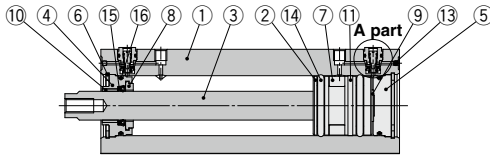

ø32 to ø100

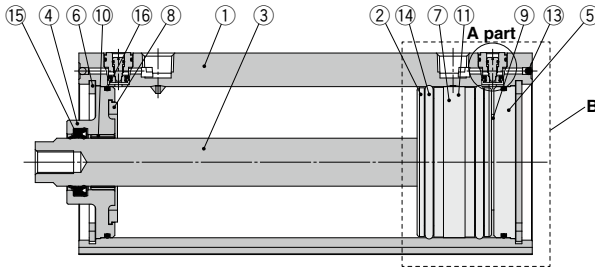

Details of B part (ø32 to ø50)

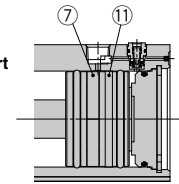

M: Rod end male thread

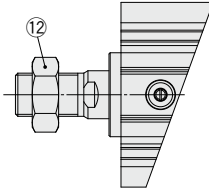

\* The magnet will only be installed when the magnet for auto switches option is selected.

### Component Parts

No.	Description	Material	Note
1	Cylinder tube	Aluminum alloy	Hard anodized
2	Piston	Aluminum alloy	
3	Piston rod	Stainless steel	ø20, ø25
		Carbon steel	ø32 to ø100 Hard chrome plated
4	Collar	Aluminum alloy	Anodized
5	Bottom plate	Aluminum alloy	Anodized
6	Retaining ring	Carbon tool steel	Phosphate coating
7	Magnet	—	With auto switch magnet
8	Bumper A	Urethane	
9	Bumper B	Urethane	
10	Bushing	Bearing alloy	
11	Wear ring	Resin	
12	Rod end nut	Carbon steel	Zinc chromated
13	Steel ball	High carbon chrome bearing steel	
14	Piston seal	NBR	
15	Rod seal	NBR	
16	Tube gasket	NBR	
17	Check seal retainer	Brass	Electroless nickel plated
18	Cushion needle	Stainless steel	
19	Check seal	NBR	
20	Check gasket	NBR	
21	Needle gasket	NBR	

### Replacement Parts/Seal Kit

Bore size (mm)	Part no.	Contents
20	RQA20-L-PS	Set of nos. above 14, 15, 16, and a grease pack (GR-S-010)
25	RQA25-L-PS	
32	RQA32-L-PS	
40	RQA40-L-PS	
50	RQA50-L-PS	Set of nos. above 14, 15, 16, and a grease pack (GR-S-020)
63	RQA63-L-PS	
80	RQA80-L-PS	
100	RQA100-L-PS	

\* Seal kit includes 14, 15 and 16. Order the seal kit, based on each bore size.

\* The seal kit includes a grease pack.

Order with the following part number when only the grease pack is needed.

Grease pack part number: GR-S-010 (10 g), GR-S-020 (20 g), GR-S-400 (400 g)

## Dimensions: $\varnothing 20$ , $\varnothing 25$

The dimensions remain the same regardless of the selection of a magnet in the "How to order" section.  
 \* For the auto switch mounting position and its mounting height, refer to pages 1054 and 1055.

### Basic type (Both ends tapped): RQA/RDQA

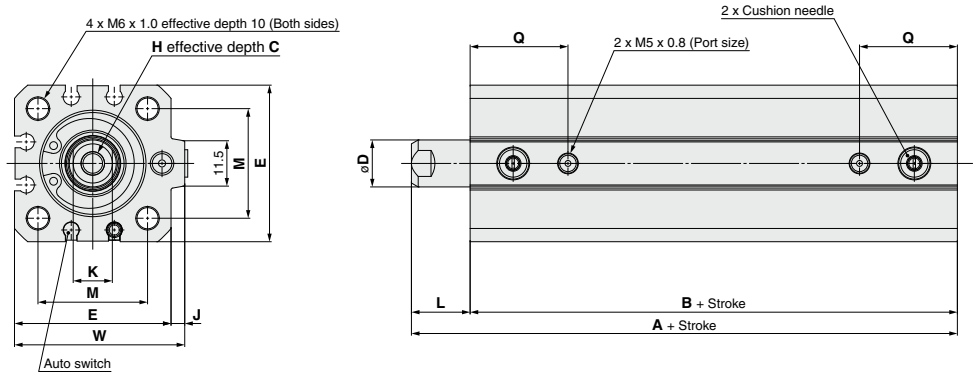

Bore size (mm)	Stroke range (mm)	A	B	C	D	E	H	J	K	L	M	Q	W
20	75 to 200	60.5	46	7	10	36	M5 x 0.8	3	8	14.5	25.5	23	39
25	75 to 200	64.5	49.5	12	12	40	M6 x 1.0	3.5	10	15	28	25	43.5

\* Refer to page 1052 for details on rod end nut and accessories.

- Add the stroke to calculate the length of intermediate strokes.

### Rod end male thread

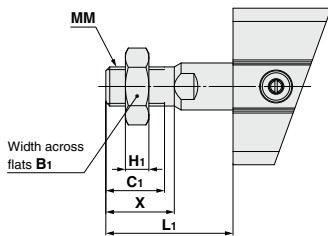

Bore size (mm)	B <sub>1</sub>	H <sub>1</sub>	C <sub>1</sub>	X	MM	L <sub>1</sub>
20	13	5	12	14	M8 x 1.25	28.5
25	17	6	15	17.5	M10 x 1.25	32.5

# RQ Series

## Mounting Bracket Dimensions

The dimensions remain the same regardless of the selection of a magnet in the "How to order" section.

### Foot type: RQL/RDQL

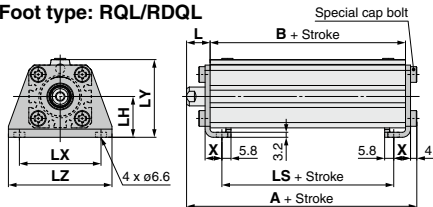

#### Rod end male thread

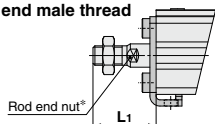

### Foot Type

Bore size (mm)	Stroke range (mm)	A	B	LS	L
20	75 to 200	67.7	46	34	14.5
25	75 to 200	71.7	49.5	34.5	15

Bore size (mm)	L1	LH	LX	LY	LZ	X
20	28.5	24	48	45	62	9.2
25	32.5	26	52	49.5	66	10.7

Foot bracket material: Carbon steel  
Surface treatment: Nickel plated

### Compact foot type: RQLC/RDQLC

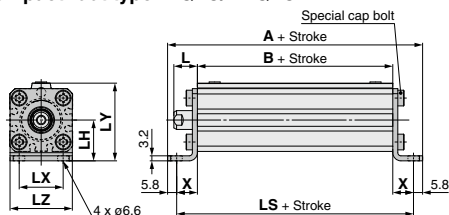

#### Rod end male thread

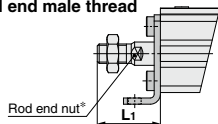

### Compact Foot Type

Bore size (mm)	Stroke range (mm)	A	B	LS	L
20	75 to 200	84	46	72.4	14.5
25	75 to 200	87.5	49.5	75.9	15

Bore size (mm)	L1	LH	LX	LY	LZ	X
20	28.5	24	25.5	45	36	13.2
25	32.5	26	28	49.5	40	13.2

Foot bracket material: Carbon steel  
Surface treatment: Zinc chromated

### Rod side flange type: RQF/RDQF

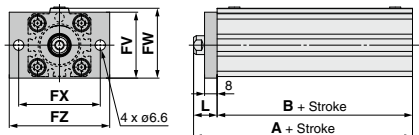

#### Rod end male thread

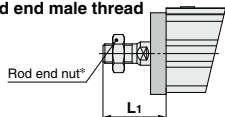

### Rod Side Flange Type

Bore size (mm)	Stroke range (mm)	A	B	L
20	75 to 200	60.5	46	14.5
25	75 to 200	64.5	49.5	15

Bore size (mm)	L1	FV	FW	FX	FZ
20	28.5	39	40.5	48	60
25	32.5	42	44.5	52	64

Flange material: Carbon steel  
Surface treatment: Nickel plated

## Mounting Bracket Dimensions

The dimensions remain the same regardless of the selection of a magnet in the "How to order" section.

### Head side flange type: RQG/RDQG

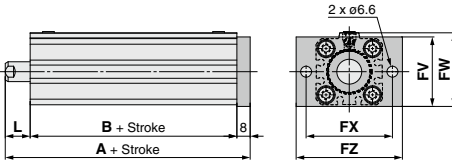

### Head side flange type

Bore size (mm)	Stroke range (mm)	A
20	75 to 200	68.5
25	75 to 200	72.5

Flange material: Carbon steel  
Surface treatment: Nickel plated

\* All dimensions but A are identical to those of the rod side flange type.

### Rod end male thread

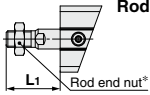

### Double clevis type: RQD/RDQD

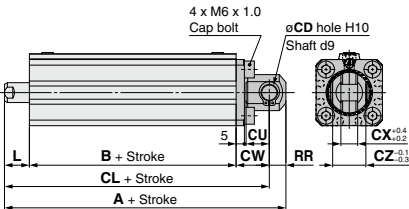

### Double clevis type

Bore size (mm)	Stroke range (mm)	A	B	CL	CD	CU
20	75 to 200	87.5	46	78.5	8	12
25	75 to 200	94.5	49.5	84.5	10	14

Bore size (mm)	CW	CX	CZ	L	L <sub>1</sub>	RR
20	18	8	16	14.5	28.5	9
25	20	10	20	15	32.5	10

\* Double clevis pins and retaining rings are included in the package.

Double clevis bracket material: Carbon steel  
Surface treatment: Nickel plated

\* Refer to pages 1052 to 1053-1 for details on the rod end nut, and accessories.

# RQ Series

The dimensions remain the same regardless of the selection of a magnet in the "How to order" section.  
 \* For the auto switch mounting position and its mounting height, refer to pages 1054 and 1055.

## Dimensions: $\varnothing 32$ , $\varnothing 40$ , $\varnothing 50$

### Basic type (Both ends tapped): RQA/RDQA

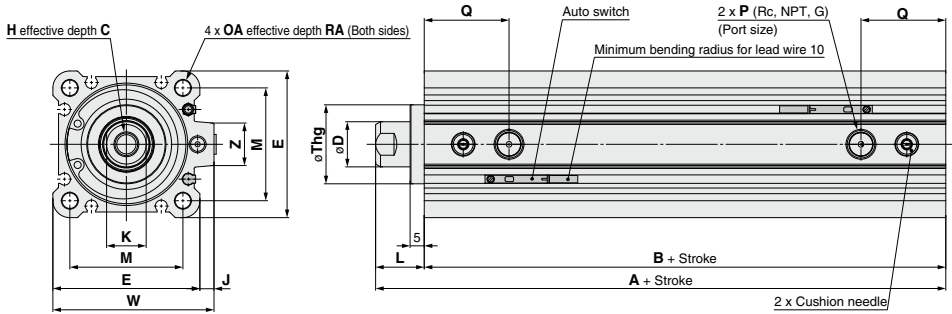

Bore size (mm)	Stroke range (mm)	A	B	C	D	E	H	J	K	L	M
32	125 to 300	67	50	13	16	45	M8 x 1.25	4.5	14	17	34
40	125 to 300	76.5	59.5	13	16	52	M8 x 1.25	5	14	17	40
50	125 to 300	80.5	62.5	15	20	64	M10 x 1.5	7	17	18	50

Bore size (mm)	OA	P	Q	RA	Th9	W	Z
32	M6 x 1.0	1/8	25	10	22 <sup>0</sup> <sub>-0.052</sub>	49.5	14
40	M6 x 1.0	1/8	30	10	28 <sup>0</sup> <sub>-0.052</sub>	57	15
50	M8 x 1.25	1/4	32.5	14	35 <sup>0</sup> <sub>-0.062</sub>	71	19

\* Add the stroke to calculate the length of intermediate strokes.

### Rod end male thread

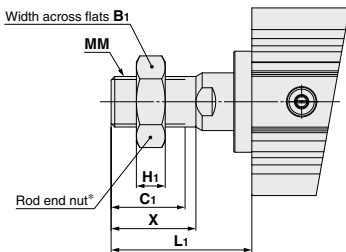

Bore size (mm)	B <sub>1</sub>	H <sub>1</sub>	C <sub>1</sub>	X	MM	L <sub>1</sub>
32	22	8	20.5	23.5	M14 x 1.5	38.5
40	22	8	20.5	23.5	M14 x 1.5	38.5
50	27	11	26	28.5	M18 x 1.5	43.5

## Mounting Bracket Dimensions

The dimensions remain the same regardless of the selection of a magnet in the "How to order" section.

### Foot type: RQL/RDQL

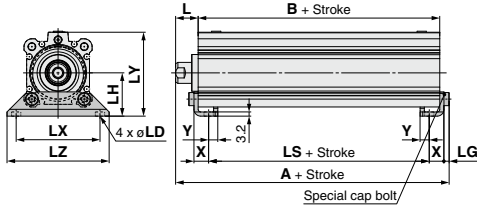

#### Rod end male thread

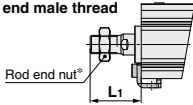

### Foot type

Bore size (mm)	Stroke range (mm)	A	B	LS	L	L1	LD
32	125 to 300	74.2	50	34	17	38.5	6.6
40	125 to 300	83.7	59.5	43.5	17	38.5	6.6
50	125 to 300	88.7	62.5	39.5	18	43.5	9

Bore size (mm)	LG	LH	LX	LY	LZ	X	Y
32	4	30	57	57	71	11.2	5.8
40	4	33	64	64	78	11.2	7
50	5	39	79	78	95	14.7	8

Foot bracket material: Carbon steel  
Surface treatment: Nickel plated

### Compact foot type: RQLC/RDQLC

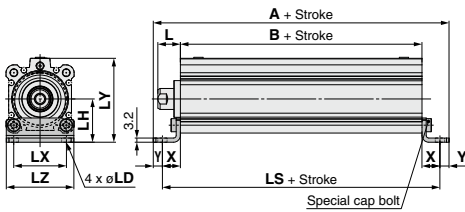

#### Rod end male thread

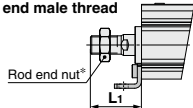

### Compact Foot Type

Bore size (mm)	Stroke range (mm)	A	B	LS	L	L1	LD
32	125 to 300	89	50	77.4	17	38.5	6.6
40	125 to 300	100.9	59.5	86.9	17	38.5	6.6
50	125 to 300	111.9	62.5	95.9	18	43.5	9

Bore size (mm)	LH	LX	LY	LZ	X	Y
32	30	34	57	45	13.7	5.8
40	33	40	64	52	13.7	7
50	39	50	78	64	16.7	8

Foot bracket material: Carbon steel  
Surface treatment: Zinc chromated

### Rod side flange type: RQF/RDQF

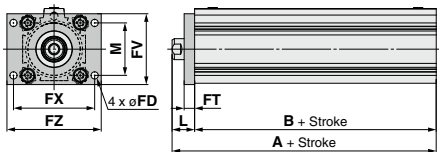

#### Rod end male thread

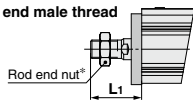

### Rod Side Flange Type

Bore size (mm)	Stroke range (mm)	A	B	FD	FT	FV
32	125 to 300	67	50	5.5	8	48
40	125 to 300	76.5	59.5	5.5	8	54
50	125 to 300	80.5	62.5	6.6	9	67

Bore size (mm)	FX	FZ	L	L1	M
32	56	65	17	38.5	34
40	62	72	17	38.5	40
50	76	89	18	43.5	50

Flange material: Carbon steel  
Surface treatment: Nickel plated

# RQ Series

## Mounting Bracket Dimensions

The dimensions remain the same regardless of the selection of a magnet in the "How to order" section.

### Head side flange type: RQG/RDQG

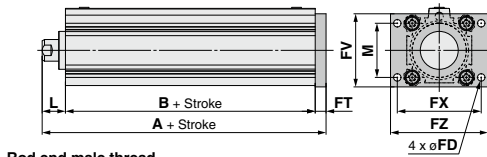

### Head side flange type

Bore size (mm)	Stroke range (mm)	A
32	125 to 300	75
40	125 to 300	84.5
50	125 to 300	89.5

Flange material: Carbon steel  
Surface treatment: Nickel plated

\* All dimensions but A are identical to those of the rod side flange type.

### Rod end male thread

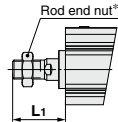

### Double clevis type: RQD/RDQD

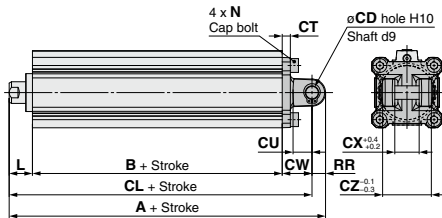

### Double clevis type

Bore size (mm)	Stroke range (mm)	A	B	CL	CD	CT	CU
32	125 to 300	97	50	87	10	5	14
40	125 to 300	108.5	59.5	98.5	10	6	14
50	125 to 300	122.5	62.5	108.5	14	7	20

Bore size (mm)	CW	CX	CZ	L	L1	N	RR
32	20	18	36	17	38.5	M6 x 1.0	10
40	22	18	36	17	38.5	M6 x 1.0	10
50	28	22	44	18	43.5	M8 x 1.25	14

\* Double clevis pins and retaining rings are included in the package.

Double clevis bracket material: Cast iron  
Surface treatment: Painted

\* Refer to pages 1052 to 1053-1 for details on the rod end nut, and accessories.

The dimensions remain the same regardless of the selection of a magnet in the "How to order" section.  
 \* For the auto switch mounting position and its mounting height, refer to pages 1054 and 1055.

## Dimensions: $\varnothing 63$ , $\varnothing 80$ , $\varnothing 100$

### Basic type (Both ends tapped): RQA/RDQA

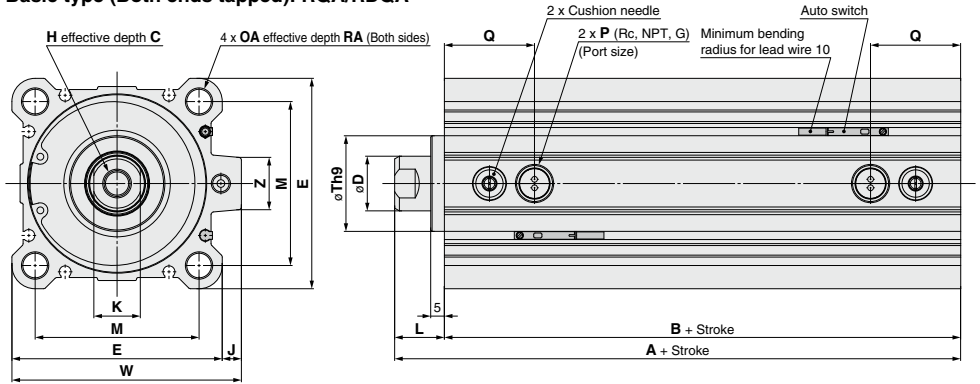

Bore size (mm)	Stroke range (mm)	A	B	C	D	E	H	J	K	L	M
63	125 to 300	82	64	15	20	77	M10 x 1.5	7	17	18	60
80	125 to 300	95	75	21	25	98	M16 x 2.0	6	22	20	77
100	125 to 300	108.5	86.5	27	30	117	M20 x 2.5	6.5	27	22	94

Bore size (mm)	OA	P	Q	RA	Th9	W	Z
63	M10 x 1.5	1/4	33	18	35 <sup>0</sup> <sub>0.062</sub>	84	19
80	M12 x 1.75	3/8	39	22	43 <sup>0</sup> <sub>0.062</sub>	104	25
100	M12 x 1.75	3/8	45	22	59 <sup>0</sup> <sub>0.074</sub>	123.5	25

\* Add the stroke to calculate the length of intermediate strokes.

### Rod end male thread

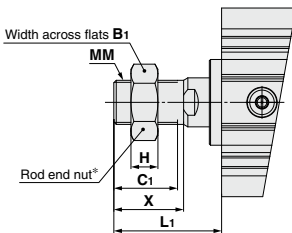

Bore size (mm)	B <sub>1</sub>	H <sub>1</sub>	C <sub>1</sub>	X	MM	L <sub>1</sub>
63	27	11	26	28.5	M18 x 1.5	43.5
80	32	13	32.5	35.5	M22 x 1.5	53.5
100	41	16	32.5	35.5	M26 x 1.5	53.5

## Mounting Bracket Dimensions

The dimensions remain the same regardless of the selection of a magnet in the "How to order" section.

### Foot type: RQL/RDQL

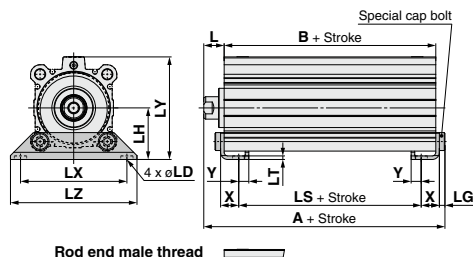

### Foot Type

Bore size (mm)	Stroke range (mm)	A	B	LS	L	L <sub>1</sub>	LD	LG	LH	LT	mm
63	125 to 300	90.2	64	38	18	43.5	11	5	46	3.2	
80	125 to 300	106.5	75	45	20	53.5	13	7	59	4.5	
100	125 to 300	121.5	86.5	52.5	22	53.5	13	7	71	6	

Bore size (mm)	LX	LY	LZ	X	Y
63	95	91.5	113	16.2	9
80	118	114	140	19.5	11
100	137	136	162	23	12.5

Foot bracket material: Carbon steel  
Surface treatment: Nickel plated

### Compact foot type: RQLC/RDQLC

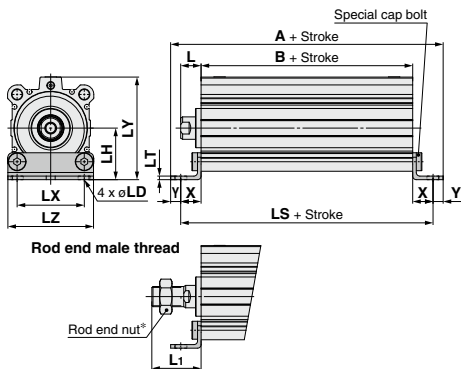

### Compact Foot Type

Bore size (mm)	Stroke range (mm)	A	B	LS	L	L <sub>1</sub>	LD	LH	LT	mm
63	125 to 300	118.4	64	100.4	18	43.5	11	46	3.2	
80	125 to 300	142	75	120	20	53.5	13	59	4.5	
100	125 to 300	159.5	86.5	134.5	22	53.5	13	71	6	

Bore size (mm)	LX	LY	LZ	X	Y
63	60	91.5	77	18.2	9
80	77	114	98	22.5	11
100	94	136	117	24	12.5

Foot bracket material: Carbon steel  
Surface treatment: Zinc chromated

### Rod side flange type: RQF/RDQF

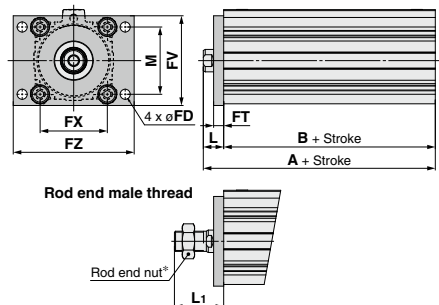

### Rod Side Flange Type

Bore size (mm)	Stroke range (mm)	A	B	FD	FT	FV	FX	FZ	L	L <sub>1</sub>	M	mm
63	125 to 300	82	64	9	9	80	92	108	18	43.5	60	
80	125 to 300	95	75	11	11	99	116	134	20	53.5	77	
100	125 to 300	108.5	86.5	11	11	117	136	154	22	53.5	94	

Flange material: Carbon steel  
Surface treatment: Nickel plated

## Mounting Bracket Dimensions

The dimensions remain the same regardless of the selection of a magnet in the "How to order" section.

### Head side flange type: RQG/RDQG

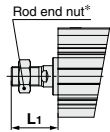
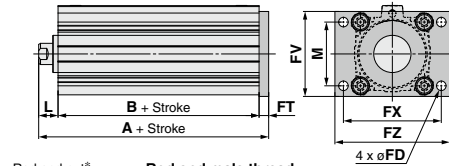

Rod end male thread

### Head side flange type

Bore size (mm)	Stroke range (mm)	A
63	125 to 300	91
80	125 to 300	106
100	125 to 300	119.5

Flange material: Carbon steel  
Surface treatment: Nickel plated

\* All dimensions but A are identical to those of the rod side flange type.

### Double clevis type: RQD/RDQD

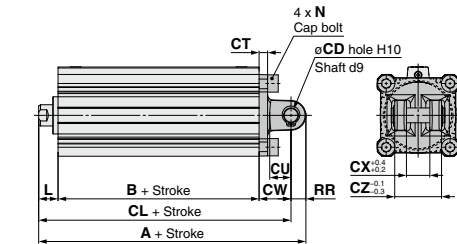

### Double clevis type

Bore size (mm)	Stroke range (mm)	A	B	CL	CD	CT	CU	CW	CX	CZ	L
63	125 to 300	126	64	112	14	8	20	30	22	44	18
80	125 to 300	151	75	133	18	10	27	38	28	56	20
100	125 to 300	175.5	86.5	153.5	22	13	31	45	32	64	22

Bore size (mm)	L1	N	RR
63	43.5	M10 x 1.5	14
80	53.5	M12 x 1.75	18
100	53.5	M12 x 1.75	22

\* Double clevis pins and retaining rings are included in the package.

Double clevis bracket material: Cast iron  
Surface treatment: Painted

\* Refer to pages 1052 to 1053-1 for details on the rod end nut, and accessories.

# Auto Switch Mounting 1

## Minimum Auto Switch Mounting Stroke

No. of auto switch mounted	D-M9□ D-M9□V D-M9□W D-M9□WV	D-M9□A D-M9□AV D-A9□ D-A9□V	D-A7□/A80 D-A73C/A80C D-A7□H/A80H D-F7□/J79	D-F7□V D-J79C D-F7□WV D-F7BAV	D-A79W	D-F7□W D-J79W D-F7BA	D-F7NT D-F79F	D-P3DWA
1 pc.	15		15		15	20 (15)		15
2 pcs.	15		15		20	20		15

Note) The dimension stated in ( ) shows the minimum mountable stroke when the auto switch does not project from the end face of the cylinder body and the lead wire bending space is not hindered. (Refer to the figure on the right.) Order auto switches and auto switch mounting brackets separately.

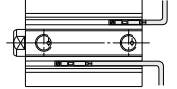

## Proper Auto Switch Mounting Position (Detection at stroke end) and Its Mounting Height

ø20/ø25

D-M9□  
D-M9□W  
D-M9□A  
D-A9□

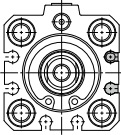

D-M9□V  
D-M9□WV  
D-M9□AV  
D-A9□V

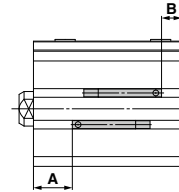
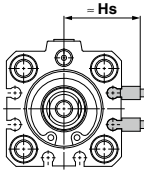

ø32 to ø100

D-M9□  
D-M9□W  
D-M9□A  
D-A9□

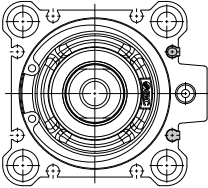

D-M9□V  
D-M9□WV  
D-M9□AV  
D-A9□V

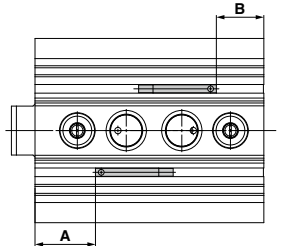
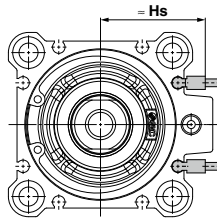

ø32 to ø100

D-A7□  
D-A80  
D-A7□H  
D-A80H  
D-F7□  
D-J79  
D-F7□W  
D-J79W  
D-F79F

D-F7NT  
D-F7BA  
D-A73C  
D-A80C  
D-J79C  
D-A79W  
D-F7□V  
D-F7□WV  
D-F7BAV

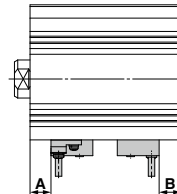
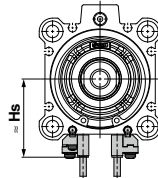

ø25

D-P3DWA

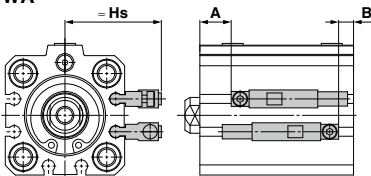

ø32 to ø100

D-P3DWA

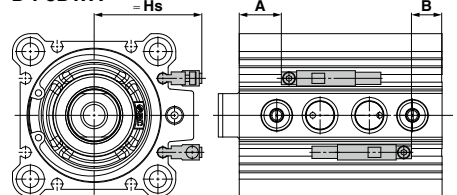

**Proper Auto Switch Mounting Position**

Applicable cylinder series: RDQ (Standard stroke)

(mm)

Auto switch model	D-M9□ D-M9□V D-M9□W D-M9□WV D-M9□A D-M9□AV		D-A9□ D-A9□V		D-A73 D-A80		D-A72/A7□H/A80H D-A73C/A80C/F□ D-F79F/J79/F□V D-F79C/F7□W D-J79W/F7□WV D-F7BAV/F7BA		D-F7NT		D-A79W		D-P3DWA	
	A	B	A	B	A	B	A	B	A	B	A	B	A	B
20	13.5	7	9.5	3	—	—	—	—	—	—	—	—	—	—
25	15	9.5	11	5.5	—	—	—	—	—	—	—	—	10.5	5
32	16.5	8.5	12.5	4.5	13.5	5.5	14	6	19	11	11	3	12	4
40	21	11	17	7	18	8	18.5	8.5	23.5	13.5	15.5	5.5	16.5	6.5
50	21	16.5	17	12.5	18	13.5	18.5	14	23.5	19	15.5	11	16.5	12
63	23.5	19.5	19.5	15.5	20.5	16.5	21	17	26	22	18	14	19	15
80	28.5	23	24.5	19	25.5	20	26	20.5	31	25.5	23	17.5	24	18.5
100	35	29	31	25	32	26	32.5	26.5	37.5	31.5	29.5	23.5	30.5	24.5

Applicable cylinder series: RDQ (Long stroke)

(mm)

Auto switch model	D-M9□ D-M9□V D-M9□W D-M9□WV D-M9□A D-M9□AV		D-A9□ D-A9□V		D-A73 D-A80		D-A72/A7□H/A80H D-A73C/A80C/F□ D-F79F/J79/F□V D-F79C/F7□W D-J79W/F7□WV D-F7BAV/F7BA		D-F7NT		D-A79W		D-P3DWA	
	A	B	A	B	A	B	A	B	A	B	A	B	A	B
20	15.5	18	11.5	14	—	—	—	—	—	—	—	—	—	—
25	17	20	13	16	—	—	—	—	—	—	—	—	12.5	15.5
32	17	21	13	17	14	18	14.5	18.5	19.5	23.5	11.5	15.5	12.5	16.5
40	21.5	26	17.5	22	18.5	23	19	23.5	24	28.5	16	20.5	17	21.5
50	21	29	17	25	18	26	18.5	26.5	23.5	31.5	15.5	23.5	16.5	24.5
63	25.5	26.5	21.5	22.5	22.5	23.5	23	24	28	29	20	21	21	22
80	30.5	32	26.5	28	27.5	29	28	29.5	33	34.5	25	26.5	26	27.5
100	36.5	37.5	32.5	33.5	33.5	34.5	34	35	39	40	31	32	32	33

Note) Adjust the auto switch after confirming the operating condition in the actual setting.

**Operating Range**

**Auto Switch Mounting Height**

(mm)

Auto switch model	D-M9□V D-M9□WV D-M9□AV		D-A9□V	D-A7□ D-A80	D-F7□/J79 D-F7W/J79W D-F7BA/F79F D-F7NT D-A7□H/A80H
	Hs	Hs	Hs	Hs	Hs
20	24.5	22.5	—	—	—
25	26.5	24.5	—	—	—
32	30	27.5	34	36	—
40	32	30	37.5	38	—
50	37.5	35	43	43.5	—
63	42.5	40.5	48	48.5	—
80	51	49	56.5	57	—
100	59	57	64.5	65.5	—

(mm)

Auto switch model	D-F7□V D-F7□WV		D-J79C	D-A73C D-A80C	D-A79W	D-P3DWA
	Hs	Hs	Hs	Hs	Hs	Hs
20	—	—	—	—	—	—
25	—	—	—	—	—	33
32	36.5	39.5	40.5	37.5	35.5	—
40	40	42.5	43.5	40.5	38	—
50	45	48	49	46	43	—
63	50.5	53.5	54.5	51.5	48	—
80	59	61.5	62.5	49.5	56.5	—
100	67	70	71	68	65	—

Auto switch model	Bore size							
	20	25	32	40	50	63	80	100
D-M9□/M9□V D-M9□W/M9□WV D-M9□A/M9□AV	5.5	6	6	6	7	9.5	10	11
D-A9□/A9□V	10	10	9.5	9.5	9.5	12	9	12
D-A73/A80 D-A7□H/A80H D-A73C/A80C	—	—	12	11	10	12	12	13
D-A79W	—	—	6	14	14	16	15	17
D-F7□/F7□V D-J79/J79C/J79W D-F7□W/F7□WV D-F79F/F7BA D-F7BAV/F7NT	—	—	13	6	6	6.5	6.5	7
D-P3DWA	—	6	6	6	6	8.5	9	9





# RQ Series

## Specific Product Precautions

Be sure to read this before handling the products. For safety instructions as well as actuator and auto switch precautions, refer to the "Handling Precautions for SMC Products" and the "Operation Manual" of each product on the SMC website.

### Installation and Removal of Retaining Ring

#### ⚠ Caution

1. Use appropriate pliers (Type C retaining ring installing tool) for installation and removal.
2. Even when using appropriate pliers (Type C retaining ring installing tool), proceed with caution as there is a danger of the retaining ring flying off the end of the pliers (Type C retaining ring installing tool) and causing human injury or damage to nearby equipment. After installation, confirm that the retaining ring is securely seated into the retaining ring groove before supplying air.

### Selection

#### ⚠ Caution

1. Operate the cylinder to the stroke end.  
When the stroke is restricted by an external stopper or a clamped work piece, satisfactory cushioning and noise reduction may not be achieved.
  2. Strictly observe the limiting ranges for load mass and maximum speed (Graph (1)). Also, the limiting ranges are based on operation of the cylinder to the stroke end and proper adjustment of the cushion needle.
- If operated beyond the limiting ranges, excessive impact will occur and this may cause damage to equipment.

Graph (1)

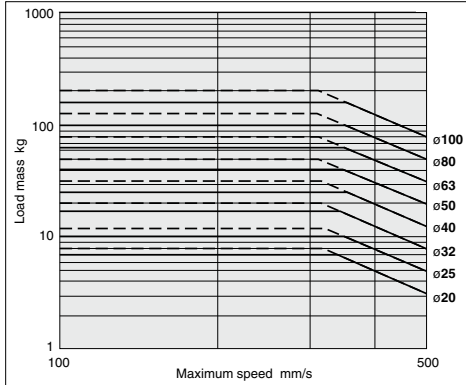

3. Adjust the cushion needle to reduce excessive kinetic energy from the piston impact at the stroke end by absorbing enough kinetic energy during the cushion stroke.

If the piston impacts the stroke end with excessive kinetic energy (values in Table 1 or more), an excessive impact will occur and this may cause damage to equipment.

Table (1) Allowable Kinetic Energy At Piston Impact Unit: [J]

Bore size	ø20	ø25	ø32	ø40	ø50	ø63	ø80	ø100	
	Piston speed	50 to 500 mm/s							
Allowable kinetic energy	Standard stroke	0.055	0.09	0.15	0.26	0.46	0.77	1.36	2.27
	Long stroke	0.11	0.18	0.29	0.52	0.91	1.54	2.71	4.54

### Selection

#### ⚠ Caution

4. Strictly observe the limiting ranges for the piston rod lateral load (Graph (2)).

If operated beyond the limiting ranges, this may cause the equipment life to be reduced or damage to equipment may occur.

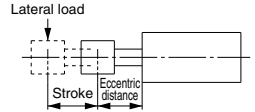

Graph (2)

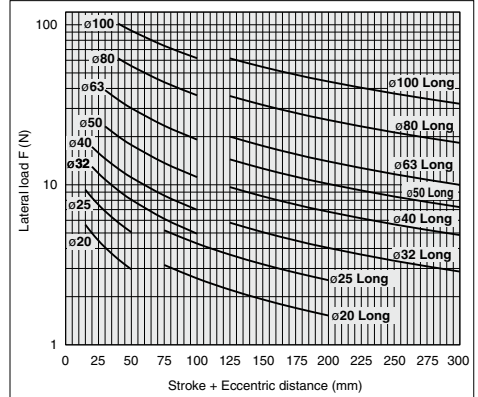

### Cushion Needle Adjustment

#### ⚠ Caution

1. Readjust with a Cushion Needle

When the product is shipped, the cushion needle is open 1/4 to 1/2 turn from the fully closed position. Readjust the position depending on the load or operating speed before using.

Note that the needle must be fully closed first, and then gradually reopened when adjusting.

2. Keep the adjustment range for the cushion needle between the closed position and the rotations shown below.

	Rotations
ø20 to ø100	2.5 rotations or less

Use a 3 mm flat head watchmakers screw driver to adjust the cushion needle. The adjustment range for the cushion needle must be between the closed position and the open position ranges above. A retaining mechanism prevents the cushion needle from coming out, however, it may spring out during operation if it is rotated beyond the ranges shown above.