

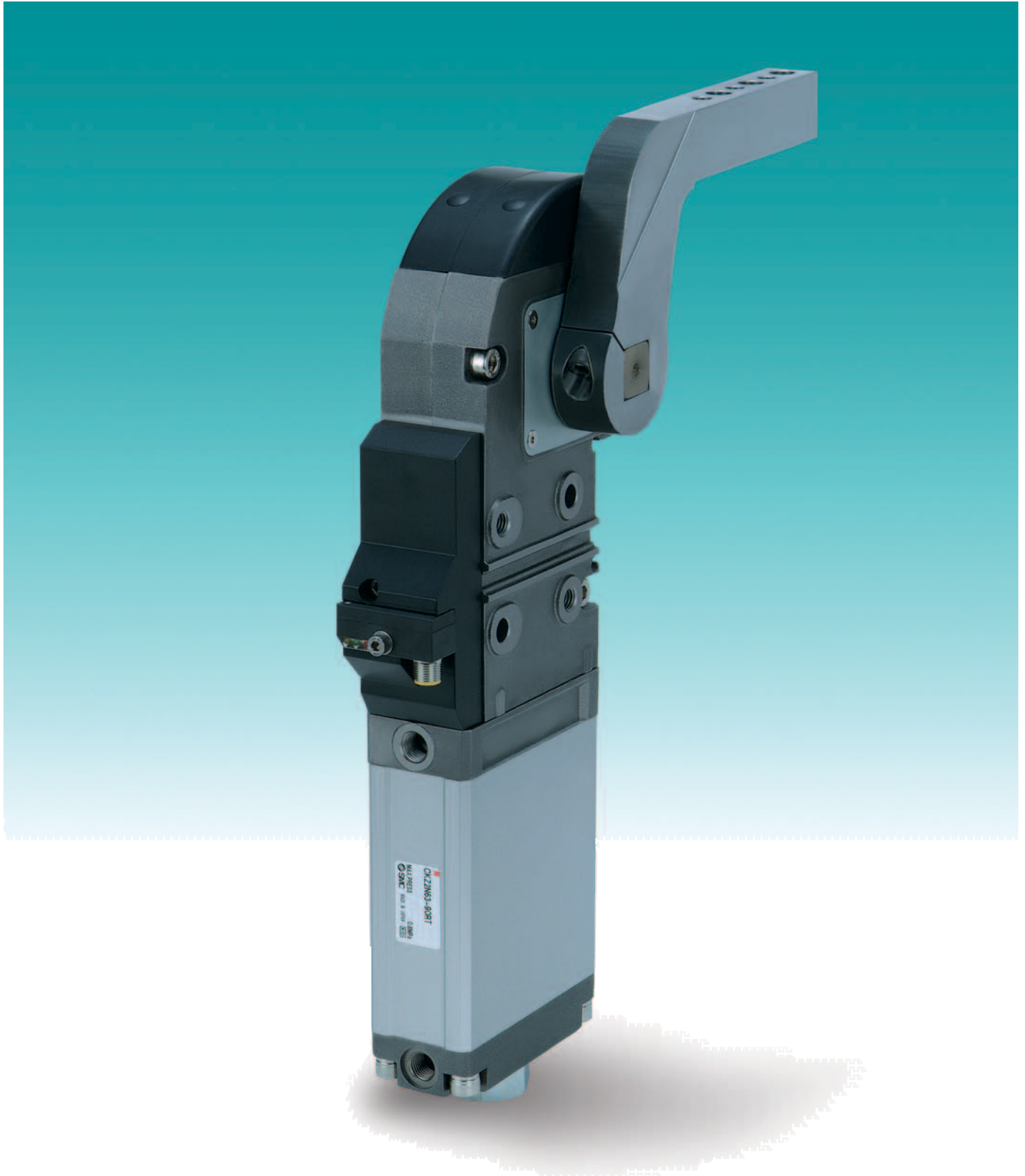

**Power Clamp Cylinder  
Conforming to the New NAAMS Standard**

**NAAMS** Compliant

# ***Series CKZ2N***



**Rounded cover design reduces weld spatter accumulation.**

The release button only protrudes a small amount. This design prevents failure of the release mechanism due to weld spatter accumulation.

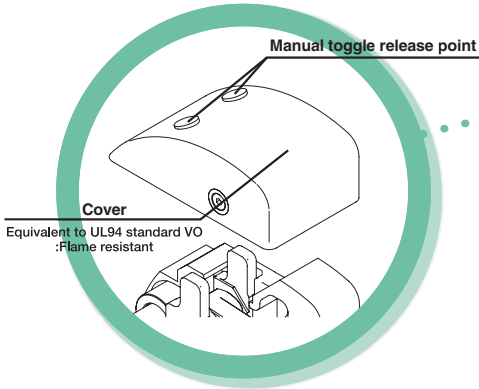

**Proximity cassette installation and removal easily accomplished by unfastening a single bolt**

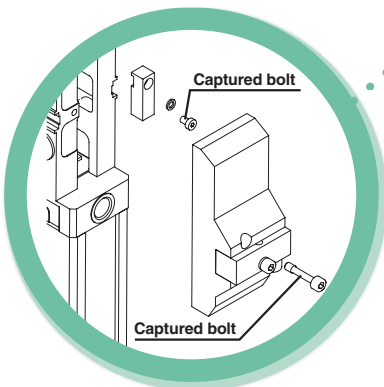

**Simple arm opening angle changes.**

Cylinder disassembly is not necessary. The arm opening angle can be changed by replacing the stopper bolt.

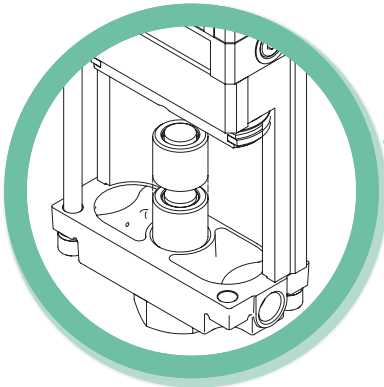

**Elliptical design for space saving**

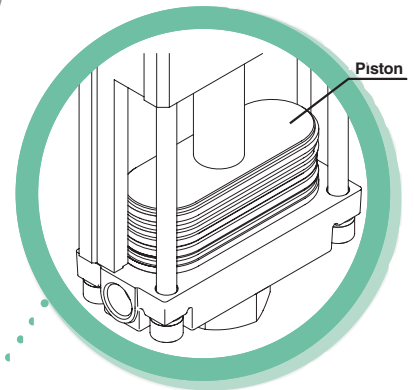

**Soft wiper on piston is standard.**

Highly protective seal design is less effected by poor air quality

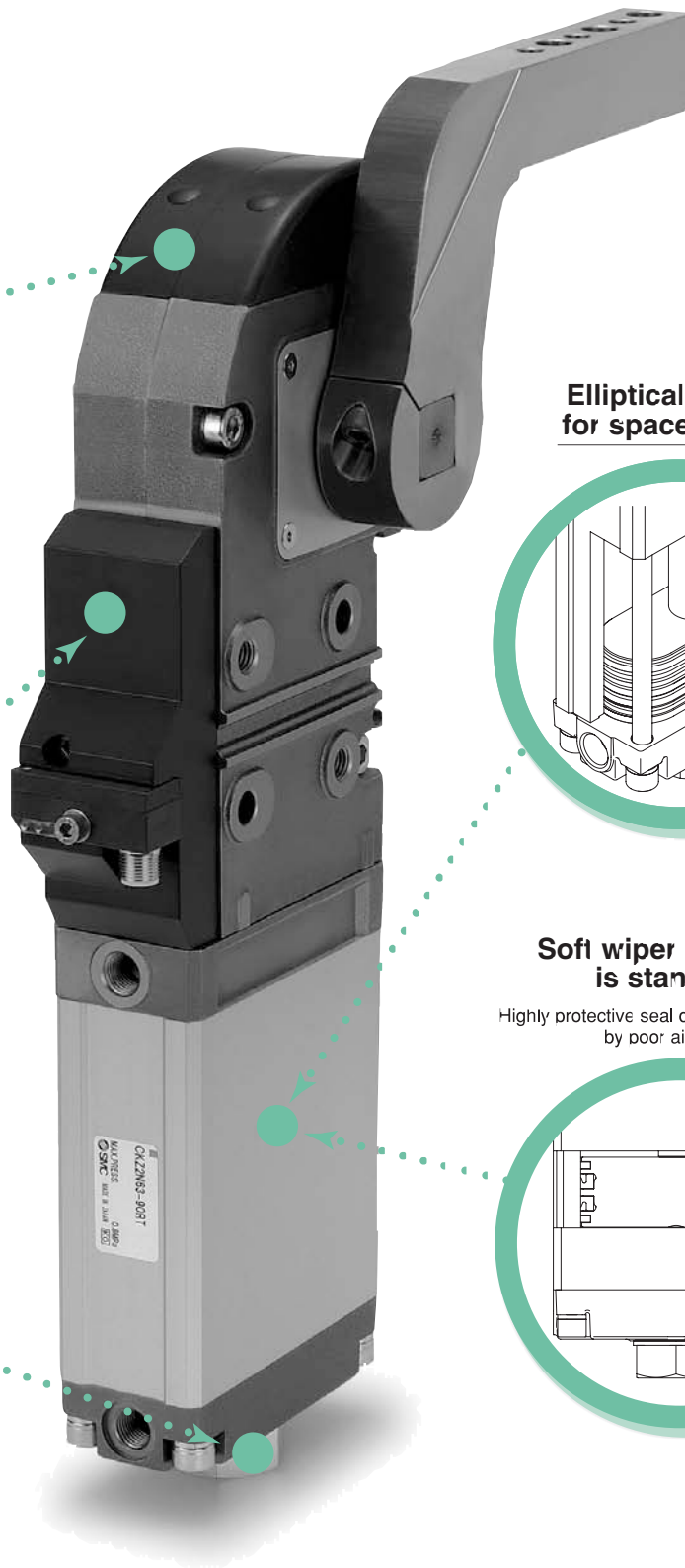
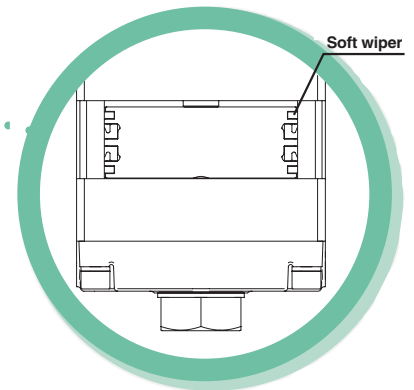

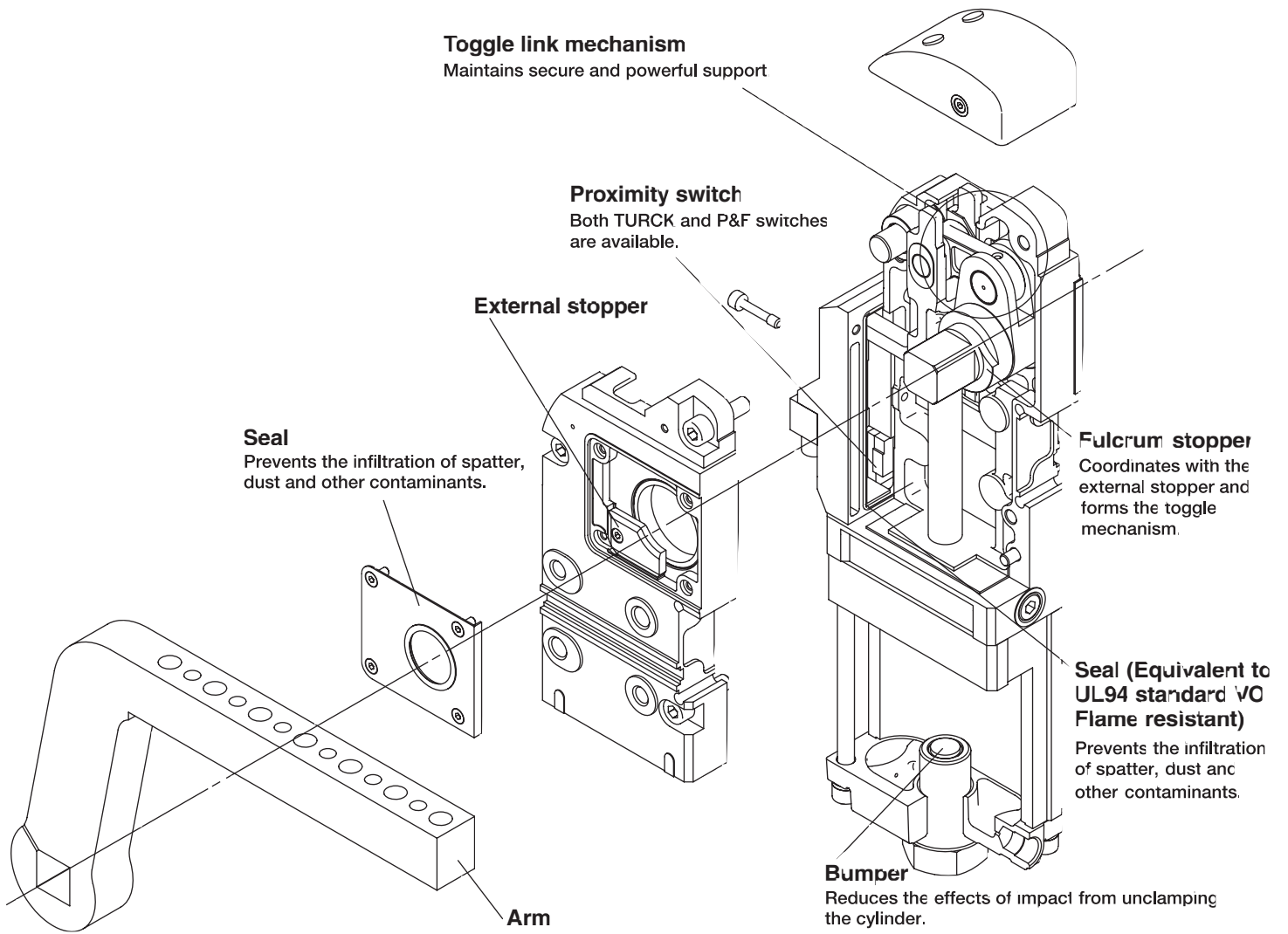

### ■ 3D CAD

Software
CATIA
UNIGRAPHICS
FIDES
AUTO CAD
SOLID WORKS

\* For additional formats, please log on to the SMC web site [www.smcusa.com](http://www.smcusa.com) and click on the E-Tech icon

### ■ Series Variations

Series	CKZ2N		
Bore size (mm)	ø50 Equivalent	ø63 Equivalent	ø80 Equivalent
Arm opening angle	30, 45, 60, 75 90, 105, 120, 135		
Switch	TURCK/P&F		
Port thread type	G/NPT		

# Power Clamp Cylinder Conforming to the New NAAMS Standard Series **CKZ2N**

ø50, ø63, ø80

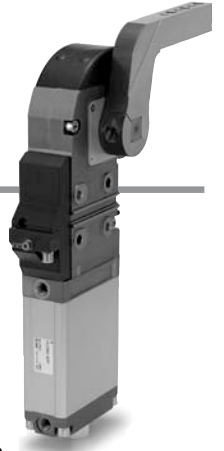

## How to Order

**CKZ2N** **63** **TF** **120** **R** **T** **A** **A002**

Power clamp cylinder conforming to the new NAAMS standard

### Bore size

50	Equivalent to 50 mm
63	Equivalent to 63 mm
80	Equivalent to 80 mm

### Cylinder port

Nil	NPT
TF	G

### Arm opening angle

30	30
45	45
60	60
75	75
90	90
105	105
120	120
135	135

### Arm style

Nil	Without arm
-	Arm code (See attached code.)

Note 1) Please indicate appropriate arm position and arm code in serial as following example in case of D type arm position.  
Note 2) Not installed when delivered.

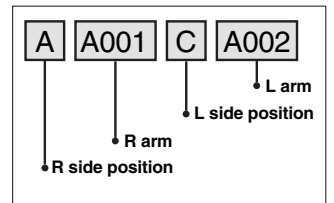

### Arm mounting position (A, B, C, D)

Note 1) See below "Arm Mounting Position"

### Arm Mounting Position: A, B, C, D

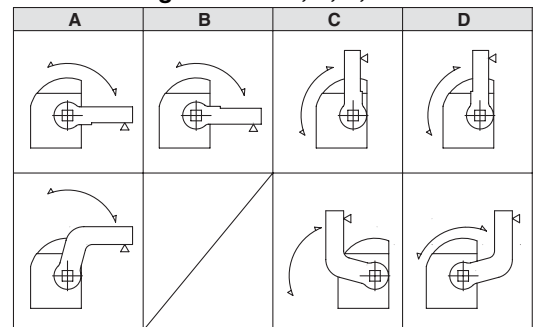

Δ denotes tool attachment surface

### Switch type

T	Turck
P	P & F

### Arm position

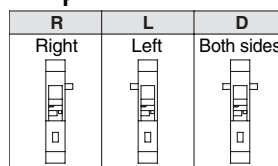

## Cylinder Specifications

Bore size (mm)	50	60	80
<b>Action</b>	Double acting		
<b>Fluid</b>	Air		
<b>Proof pressure</b>	1.2 MPa (174 psi)		
<b>Max. operating pressure</b>	0.8 MPa (116 psi)		
<b>Min. operating pressure</b>	0.3 MPa (44 psi)		
<b>Ambient and fluid temperature</b>	-10 to 60C (14 to 140F)		
<b>Cushion</b>	Clamping side: None Unclamping side: Rubber bumper		
<b>Min. operating time</b>	1.0 second to clamp, 1.0 second to unclamp		

## Weight (Cylinder Without Arm)

Unit : kg (lbs)

Bore size (mm)	Arm position	Arm angle							
		30	45	60	75	90	105	120	135
<b>50</b>	R/L	5.21 (11.46)	5.19 (11.42)	5.17 (11.37)	5.15 (11.33)	5.12 (11.26)	5.09 (11.20)	5.07 (11.15)	5.06 (11.13)
	D	5.27 (11.54)	5.25 (11.50)	5.23 (11.45)	5.21 (11.46)	5.18 (11.34)	5.15 (11.28)	5.13 (11.23)	5.12 (11.21)
<b>63</b>	R/L	7.37 (16.21)	7.34 (16.15)	7.31 (16.08)	7.28 (16.02)	7.24 (15.93)	7.21 (15.86)	7.18 (15.80)	7.16 (15.75)
	D	7.47 (16.36)	7.44 (16.29)	7.41 (16.23)	7.38 (16.16)	7.34 (16.07)	7.31 (16.01)	7.28 (15.94)	7.26 (15.90)
<b>80</b>	R/L	17.20 (37.84)	17.13 (37.69)	17.07 (37.55)	17.00 (37.40)	16.93 (37.25)	16.86 (37.09)	16.80 (36.96)	16.76 (36.87)
	D	17.42 (38.15)	17.35 (38.00)	17.29 (37.87)	17.21 (37.69)	17.15 (37.56)	17.08 (15.51)	17.02 (37.27)	16.98 (37.19)

## Switch Specifications

Manufacturer	TURCK	P & F
<b>Operating range</b>	2 mm 10%	2 mm 10%
<b>Supply voltage</b>	10 to 30 VDC	10 to 30 VDC
<b>Output</b>	N.O., PNP	N.O., PNP
<b>Continuous load current</b>	150 mA	100 mA
<b>Response frequency</b>	30 Hz	25 Hz
<b>Housing material</b>	PBT-GP30	PA6, PBT
<b>Output indication</b>	Clamping side: Red Unclamping side: Yellow	Clamping side: Red Unclamping side: Yellow
<b>Voltage indication</b>	Green	Green

Note) Switch specifications are correspondingly to manufacturer's technical information

## Wiring Diagram

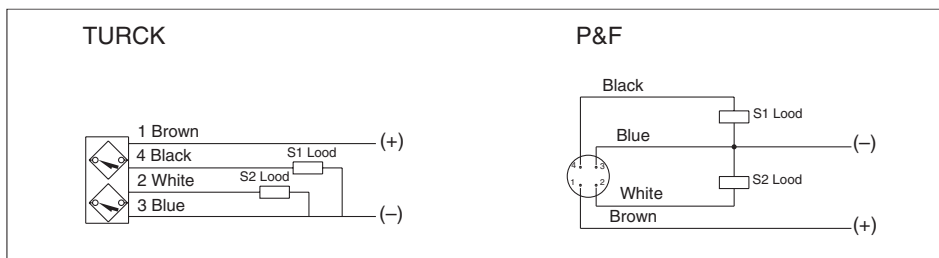

# Series CKZ2N

## Part Number (Arm)

Bore size	SMC Part Number	Code	NAAMS Ref No.
50	CKZ-50A001	A001	ACA201M
	CKZ-50A002	A002	ACA202M
	CKZ-50A003	A003	ACA203M
	CKZ-50A004	A004	ACA206M
	CKZ-50A005	A005	ACA207M
	CKZ-50A006	A006	ACA208M
	CKZ-50A007	A007	ACA211M
	CKZ-50A008	A008	ACA212M
	CKZ-50A009	A009	ACA213M
	CKZ-50A010	A010	ACA216M
	CKZ-50A011	A011	ACA217M
	CKZ-50A012	A012	ACA218M
	CKZ-50A013	A013	ACA221M
	CKZ-50A014	A014	ACA222M
	CKZ-50A015	A015	ACA223M
	CKZ-50A016	A016	ACA226M
	CKZ-50A017	A017	ACA227M
	CKZ-50A018	A018	ACA228M
	CKZ-50A019	A019	ACA236M
	CKZ-50A020	A020	ACA237M
	CKZ-50A021	A021	ACA238M
	CKZ-50A022	A022	ACA246M
	CKZ-50A023	A023	ACA247M
	CKZ-50A024	A024	ACA248M
	CKZ-50A025	A025	ACA256M
	CKZ-50A026	A026	ACA257M
	CKZ-50A027	A027	ACA258M
63	CKZ-63A001	A001	ACA001M
	CKZ-63A002	A002	ACA002M
	CKZ-63A003	A003	ACA003M
	CKZ-63A004	A004	ACA004M
	CKZ-63A005	A005	ACA005M
	CKZ-63A006	A006	ACA006M
	CKZ-63A007	A007	ACA007M
	CKZ-63A008	A008	ACA008M
	CKZ-63A009	A009	ACA009M
	CKZ-63A010	A010	ACA010M
	CKZ-63A011	A011	ACA011M

Bore size	SMC Part Number	Code	NAAMS Ref No.
63	CKZ-63A012	A012	ACA012M
	CKZ-63A013	A013	ACA013M
	CKZ-63A014	A014	ACA014M
	CKZ-63A015	A015	ACA015M
	CKZ-63A016	A016	ACA016M
	CKZ-63A017	A017	ACA017M
	CKZ-63A018	A018	ACA018M
	CKZ-63A019	A019	ACA019M
	CKZ-63A020	A020	ACA020M
	CKZ-63A021	A021	ACA021M
	CKZ-63A022	A022	ACA022M
	CKZ-63A023	A023	ACA023M
	CKZ-63A024	A024	ACA024M
	CKZ-63A025	A025	ACA025M
	CKZ-63A026	A026	ACA026M
	CKZ-63A027	A027	ACA027M
	CKZ-63A028	A028	ACA028M
	CKZ-63A029	A029	ACA029M
	CKZ-63A030	A030	ACA030M
	CKZ-63A031	A031	ACA031M
	CKZ-63A032	A032	ACA032M
	CKZ-63A033	A033	ACA033M
	CKZ-63A034	A034	ACA034M
	CKZ-63A035	A035	ACA035M
	CKZ-63A036	A036	ACA036M
	CKZ-63A037	A037	ACA037M
	CKZ-63A038	A038	ACA038M
	CKZ-63A039	A039	ACA039M
	CKZ-63A040	A040	ACA040M
	CKZ-63A041	A041	ACA041M
	CKZ-63A042	A042	ACA042M
	CKZ-63A043	A043	ACA043M
	CKZ-63A044	A044	ACA044M
	CKZ-63A045	A045	ACA045M
CKZ-63A046	A046	ACA046M	
CKZ-63A047	A047	ACA047M	
CKZ-63A048	A048	ACA048M	

Bore size	SMC Part Number	Code	NAAMS Ref No.
80	CKZ-80A001	A001	ACA100M
	CKZ-80A002	A002	ACA101M
	CKZ-80A003	A003	ACA102M
	CKZ-80A004	A004	ACA103M
	CKZ-80A005	A005	ACA104M
	CKZ-80A006	A006	ACA105M
	CKZ-80A007	A007	ACA106M
	CKZ-80A008	A008	ACA107M
	CKZ-80A009	A009	ACA108M
	CKZ-80A010	A010	ACA110M
	CKZ-80A011	A011	ACA111M
	CKZ-80A012	A012	ACA112M
	CKZ-80A013	A013	ACA113M
	CKZ-80A014	A014	ACA114M
	CKZ-80A015	A015	ACA115M
	CKZ-80A016	A016	ACA116M
	CKZ-80A017	A017	ACA117M
	CKZ-80A018	A018	ACA118M
	CKZ-80A019	A019	ACA120M
	CKZ-80A020	A020	ACA121M
	CKZ-80A021	A021	ACA122M
	CKZ-80A022	A022	ACA123M
	CKZ-80A023	A023	ACA124M
	CKZ-80A024	A024	ACA125M
	CKZ-80A025	A025	ACA126M
	CKZ-80A026	A026	ACA127M
	CKZ-80A027	A027	ACA128M
	CKZ-80A028	A028	ACA130M
	CKZ-80A029	A029	ACA131M
	CKZ-80A030	A030	ACA132M
	CKZ-80A031	A031	ACA133M
	CKZ-80A032	A032	ACA134M
	CKZ-80A033	A033	ACA135M
	CKZ-80A034	A034	ACA136M
	CKZ-80A035	A035	ACA137M
	CKZ-80A036	A036	ACA138M
	CKZ-80A037	A037	ACA140M

Bore size	SMC Part Number	Code	NAAMS Ref No.
80	CKZ-80A038	A038	ACA141M
	CKZ-80A039	A039	ACA142M
	CKZ-80A040	A040	ACA143M
	CKZ-80A041	A041	ACA144M
	CKZ-80A042	A042	ACA145M
	CKZ-80A043	A043	ACA146M
	CKZ-80A044	A044	ACA147M
	CKZ-80A045	A045	ACA148M
	CKZ-80A046	A046	ACA150M
	CKZ-80A047	A047	ACA151M
	CKZ-80A048	A048	ACA152M
	CKZ-80A049	A049	ACA153M
	CKZ-80A050	A050	ACA154M
	CKZ-80A051	A051	ACA155M
	CKZ-80A052	A052	ACA156M
	CKZ-80A053	A053	ACA157M
	CKZ-80A054	A054	ACA158M
	CKZ-80A055	A055	ACA160M
	CKZ-80A056	A056	ACA161M
	CKZ-80A057	A057	ACA162M
	CKZ-80A058	A058	ACA163M
	CKZ-80A059	A059	ACA164M
CKZ-80A060	A060	ACA165M	
CKZ-80A061	A061	ACA166M	
CKZ-80A062	A062	ACA167M	
CKZ-80A063	A063	ACA168M	
CKZ-80A064	A064	ACA170M	
CKZ-80A065	A065	ACA171M	
CKZ-80A066	A066	ACA172M	
CKZ-80A067	A067	ACA173M	
CKZ-80A068	A068	ACA174M	
CKZ-80A069	A069	ACA175M	
CKZ-80A070	A070	ACA176M	
CKZ-80A071	A071	ACA177M	
CKZ-80A072	A072	ACA178M	

Symbol is described at end of model number.

## Construction

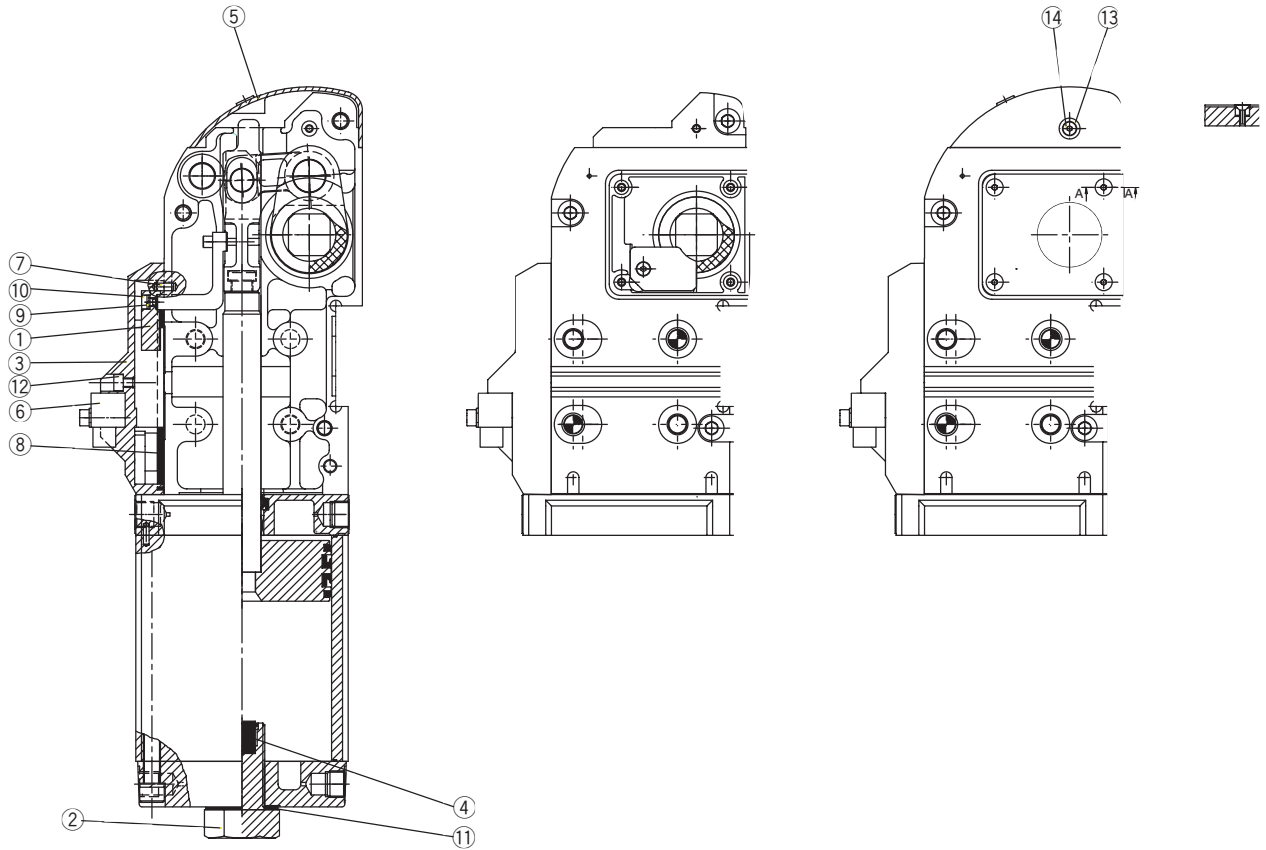

### Replaceable Kits List

Description	Bore	Kit no.	Contents
Switch cassette	50	CKZ1N-S050 <sup>T</sup> <sub>P</sub> Note 1)	③ Switch holder ⑥ Inductive switch ⑦ Parallel pin ⑧ Sheet gasket ⑫ Cover cap screw
	63	CKZ1N-S063 <sup>T</sup> <sub>P</sub> Note 1)	① Switch actuator ⑨ Spring washer ⑩ Socket head cap screw
	80	CKZ1N-S080 <sup>T</sup> <sub>P</sub> Note 1)	② Stopper bolt ④ Bumper ⑪ Seal washer
Parts for changing opening angle of arm	50	CKZN-D050 * Note 2)	① Switch actuator ⑨ Spring washer ⑩ Socket head cap screw
		CKZN-B050* Note 2)	② Stopper bolt ④ Bumper ⑪ Seal washer
		CKZN-K050* Note 2)	CKZN-D050* CKZN-B050*
	63	CKZN-D063 * Note 2)	① Switch actuator ⑨ Spring washer ⑩ Socket head cap screw
		CKZN-B063* Note 2)	② Stopper bolt ④ Bumper ⑪ Seal washer
		CKZN-K063* Note 2)	CKZN-D063* CKZN-B063*
	80	CKZN-D080 * Note 2)	① Switch actuator ⑨ Spring washer ⑩ Socket head cap screw
		CKZN-B080* Note 2)	② Stopper bolt ④ Bumper ⑪ Seal washer
		CKZN-K080* Note 2)	CKZN-D080* CKZN-B080*
Top cover kits	50	CKZ2N-T050	⑤ Top cover
	63	CKZ2N-T063	⑭ Short head cap screw
	80	CKZ2N-T080	⑬ Spacer

①	Switch actuator
②	Stopper bolt
③	Switch holder
④	Bumper
⑤	Top cover
⑥	Inductive switch
⑦	Parallel pin
⑧	Sheet gasket
⑨	Spring washer
⑩	Socket head cap screw
⑪	Seal washer
⑫	Cover cap screw
⑬	Spacer
⑭	Short head cap screw

Note 1) T: TURCK, P: P & F  
 Note 2) Please specify the opening angle by the code in Table

**Table 1**

Opening angle	Code
30	H
45	G
60	F
75	E
90	D
105	C
120	B
135	A



# Series CKZ2N

## Maximum Cylinder Locking Moment

Bore size (mm)	Max. locking force	
	N•m	lbf•in
50	800	7080
63	1500	13274
80	2500	22124

## Maximum Clamping Moment

Bore size (mm)	Max. clamping force											
	0.3 MPa		0.4 MPa		0.5 MPa		0.6 MPa		0.7 MPa		0.8 MPa	
	N•m	lbf•in	N•m	lbf•in	N•m	lbf•in	N•m	lbf•in	N•m	lbf•in	N•m	lbf•in
50	100	885	130	1150	160	1416	190	1681	220	1947	250	2212
63	300	2655	350	3097	400	3540	450	3982	500	4425	550	4867
80	560	4956	720	6372	880	7788	1040	9204	1200	10619	1360	12035

\* at 0.5MPa

## Cylinder Stroke

Unit: (mm)

Angle \ Bore size	30°	45°	60°	75°	90°	105°	120°	135°
50	31.1	38.9	46.4	54.1	61.9	69.6	76.4	81.3
63	34.1	42.5	50.5	58.6	66.8	74.7	81.5	86.3
80	47.3	59.4	71.1	83.2	95.7	108.0	119.1	127.3

## To determine actual clamp force.

Example: CKZ2N50, 0.5 MPa, distance from pivot to clamping point = 100 mm (3.937 in.)

$$N = \frac{\text{N}\cdot\text{m (from chart)} \times 1000}{\text{Distance from pivot to clamping point (mm)}} = \frac{160 \text{ N}\cdot\text{m} \times 1000}{100 \text{ mm}} = 1600 \text{ N}$$

$$\text{lbs.} = \frac{\text{lbf}\cdot\text{in (from chart)}}{\text{Distance from pivot to clamping point (in.)}} = \frac{1416 \text{ lbf}\cdot\text{in}}{3.937 \text{ in.}} = 359.69 \text{ lbf}$$

$$1600 \text{ N} \times 0.2248 = 359.68 \text{ lbf}$$



**Selection Graph**

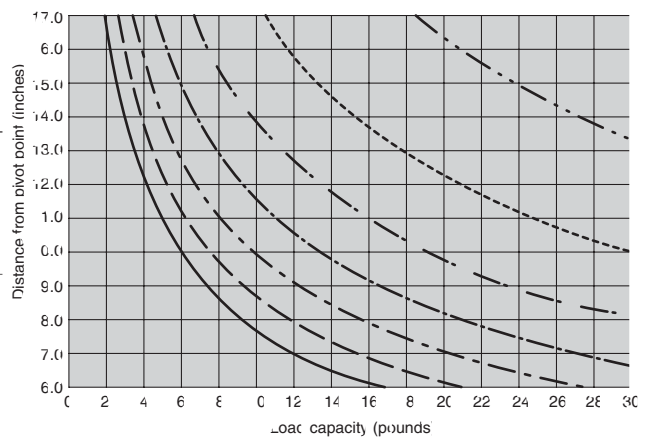
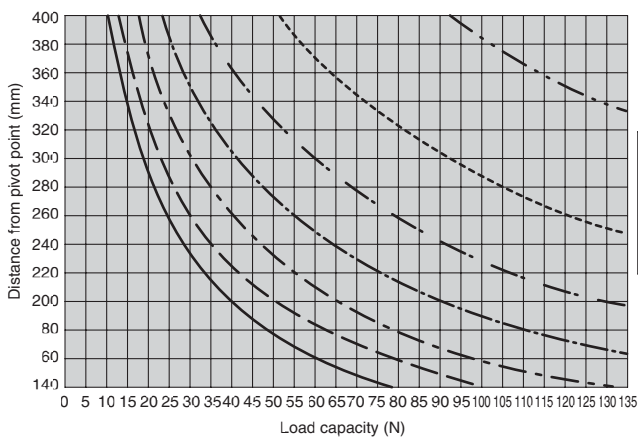
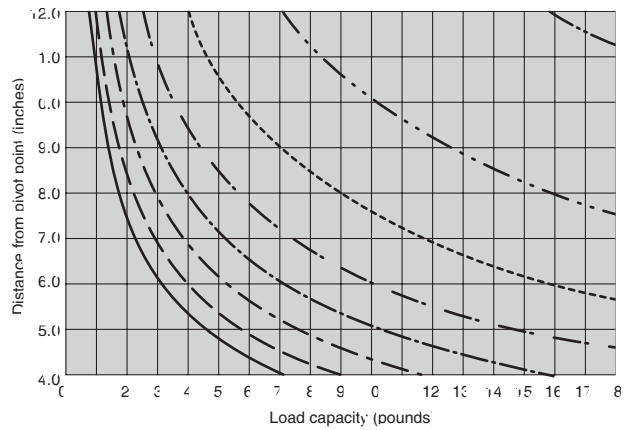
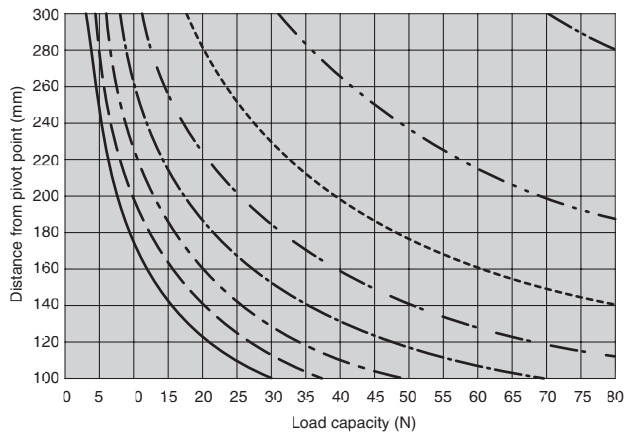
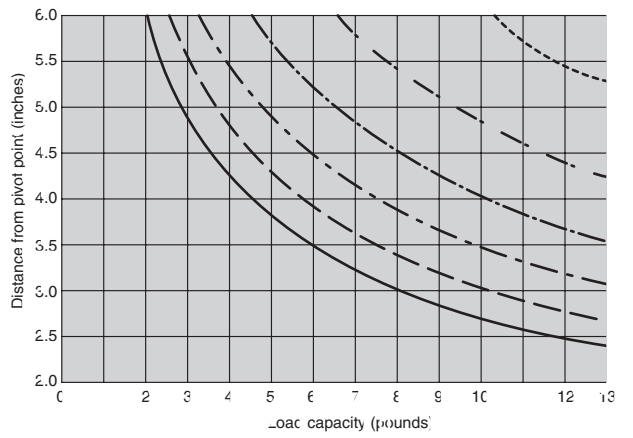
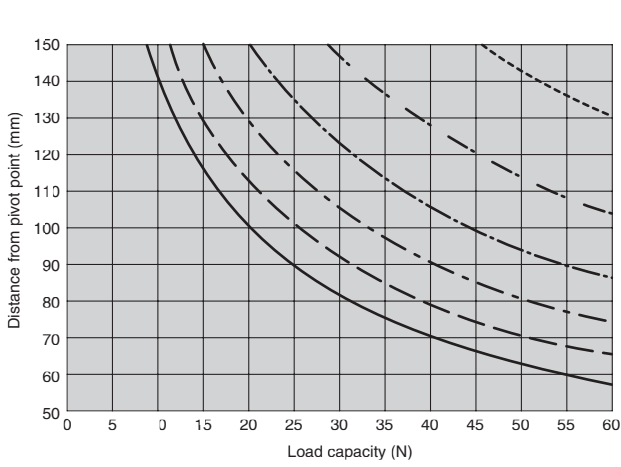

# Series CKZ2N

## Dimensions

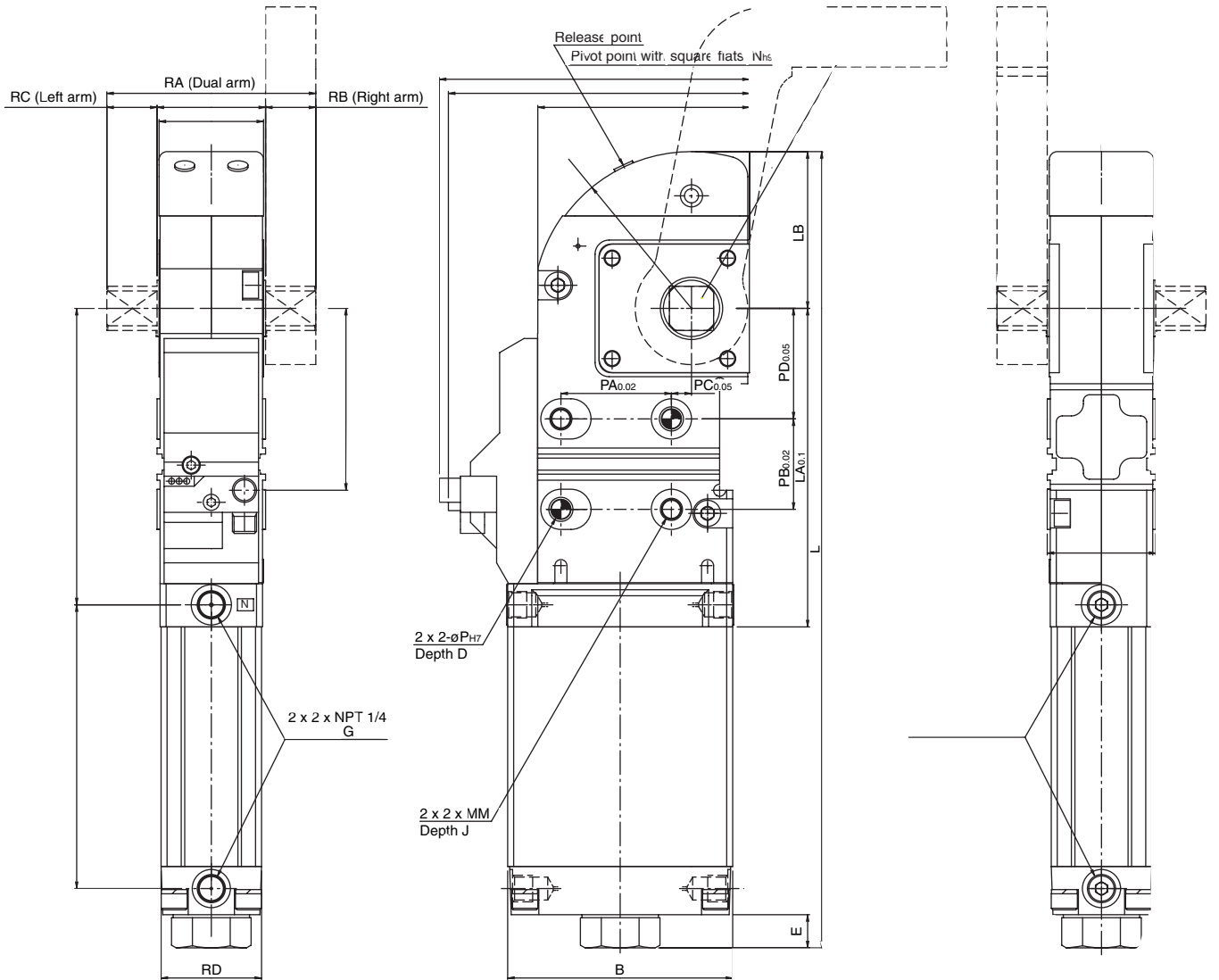

(mm)

Bore (mm)	B	C	D	E	GA	GB	GC	J	L	LA	LB	MM	N	P
50	95	48	12	13.7	134.3	138.5	93	12	376.7	149.5	78.4	M8 x 1.25	19	8
63	112	54	15	16.6	141.2	147.5	90.5	12	395.6	158.5	78	M10 x 1.5	22	10
80	154	76	12	19.6	185.8	199	137.5	18	530.9	214	113.7	M12 x 1.75	30	12

Bore (mm)	PA	PB	PC	PD	R	RA	RB	RC	RD	RR	W	XA	XB	XC
50	45	45	5	40	45	88	20	20	45	48	78.4	141.8	137.3	92.8
63	55	45	10	55	52	104	25	25	50	54	78	154.4	150.4	105.3
80	70	75	15	65	70	140	32	32	68	76	113.7	197.3	192.8	148.3

# Series CKZ2N

## Dimensions

### Arm / $\phi 50$ Straight-Plain

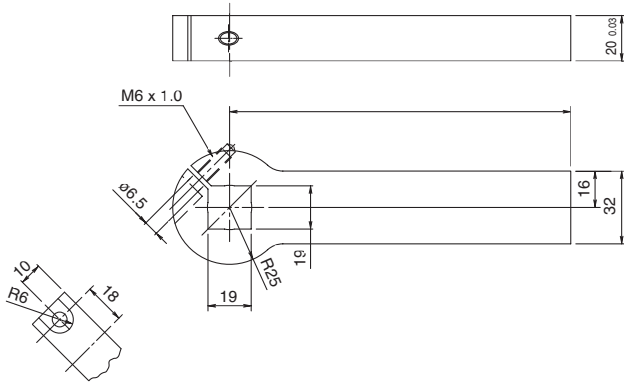

Part no.	NAAMS code	A	Weight kg (lbs)
CKZ-50A001	ACA201M	90.0	0.6 (1.32)
CKZ-50A002	ACA202M	120.0	0.7 (1.54)
CKZ-50A003	ACA203M	150.0	0.9 (1.98)

### 20 mm Offset-Plain

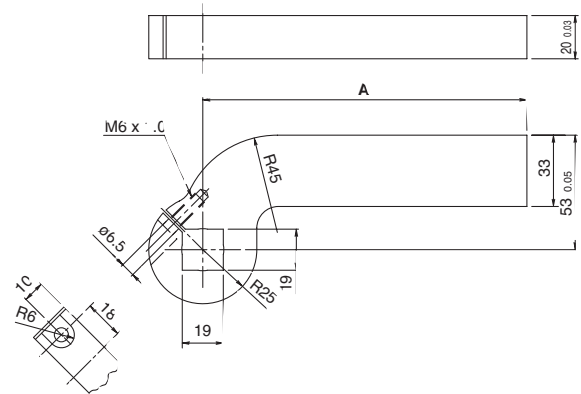

Part no.	NAAMS code	A	Weight kg (lbs)
CKZ-50A007	ACA211M	90.0	0.7 (1.54)
CKZ-50A008	ACA212M	120.0	0.8 (1.76)
CKZ-50A009	ACA213M	150.0	1.0 (2.20)

### Straight-Machined

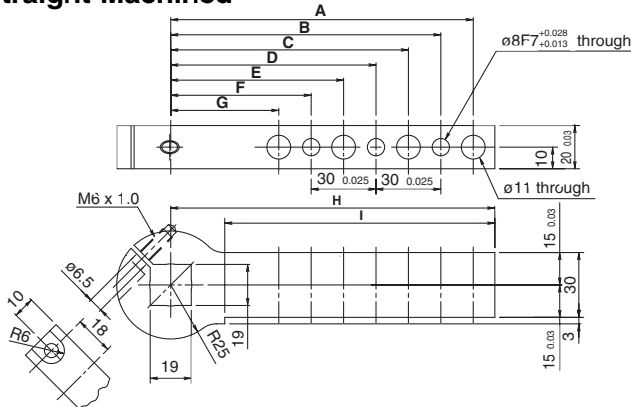

Part no.	NAAMS code	A	B	C	D	E	F	G	H	I	Weight kg (lbs)
CKZ-50A004	ACA206M	80.0	65.0	50.0	-	-	-	-	90.0	65.0	0.5 (1.10)
CKZ-50A005	ACA207M	110.0	95.0	80.0	65.0	50.0	-	-	120.0	95.0	0.6 (1.32)
CKZ-50A006	ACA208M	140.0	125.0	110.0	95.0	80.0	65.0	50.0	150.0	125.0	0.7 (1.54)

### 25 mm Offset-Machined

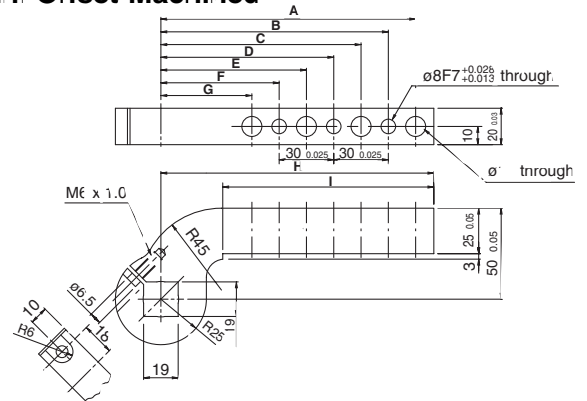

Part no.	NAAMS code	A	B	C	D	E	F	G	H	I	Weight kg (lbs)
CKZ-50A010	ACA216M	80.0	65.0	50.0	-	-	-	-	90.0	56.0	0.5 (1.10)
CKZ-50A011	ACA217M	110.0	95.0	80.0	65.0	50.0	-	-	120.0	86.0	0.6 (1.32)
CKZ-50A012	ACA218M	140.0	125.0	110.0	95.0	80.0	65.0	50.0	150.0	116.0	0.7 (1.54)

### Straight-Machined

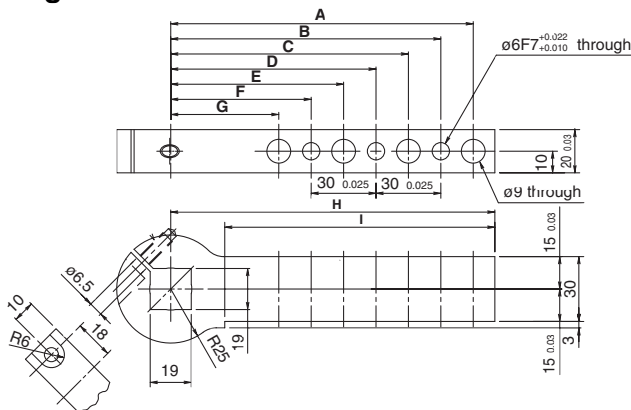

Part no.	NAAMS code	A	B	C	D	E	F	G	H	I	Weight kg (lbs)
CKZ-50A019	ACA236M	80.0	65.0	50.0	-	-	-	-	90.0	65.0	0.5 (1.10)
CKZ-50A020	ACA237M	110.0	95.0	80.0	65.0	50.0	-	-	120.0	95.0	0.6 (1.32)
CKZ-50A021	ACA238M	140.0	125.0	110.0	95.0	80.0	65.0	50.0	150.0	125.0	0.7 (1.54)

### 25 mm Offset-Machined

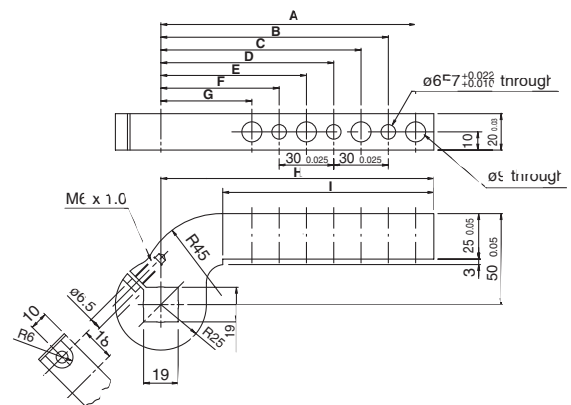

Part no.	NAAMS code	A	B	C	D	E	F	G	H	I	Weight kg (lbs)
CKZ-50A022	ACA246M	80.0	65.0	50.0	-	-	-	-	90.0	56.0	0.5 (1.10)
CKZ-50A023	ACA247M	110.0	95.0	80.0	65.0	50.0	-	-	120.0	86.0	0.6 (1.32)
CKZ-50A024	ACA248M	140.0	125.0	110.0	95.0	80.0	65.0	50.0	150.0	116.0	0.7 (1.54)

## Dimensions

### 45 mm Offset-Plain

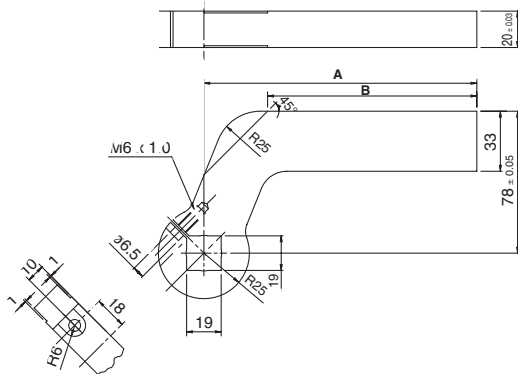

Part no.	NAAMS code	A	B	Weight kg (lbs)
CKZ-50A013	ACA221M	90.0	55.0	0.8 (1.76)
CKZ-50A014	ACA222M	120.0	85.0	0.9 (1.98)
CKZ-50A015	ACA223M	150.0	115.0	1.1 (2.42)

### 50 mm Offset-Machined

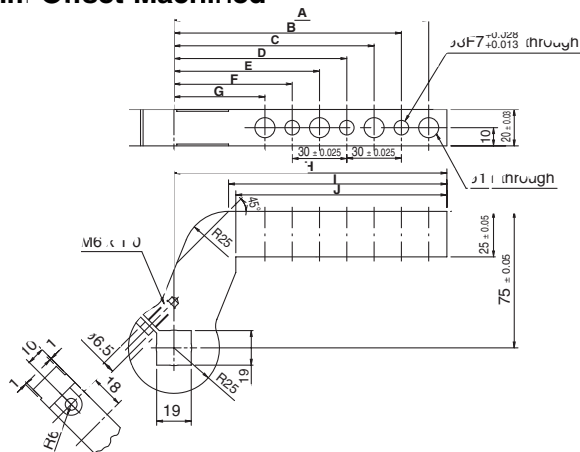

Part no.	NAAMS code	A	B	C	D	E	F	G	H	I	J	Weight kg (lbs)
CKZ-50A016	ACA226M	80.0	65.0	50.0	-	-	-	-	90.0	60.0	56.0	0.6 (1.32)
CKZ-50A017	ACA227M	110.0	95.0	80.0	65.0	50.0	-	-	120.0	90.0	86.0	0.7 (1.54)
CKZ-50A018	ACA228M	140.0	125.0	110.0	95.0	80.0	65.0	50.0	150.0	120.0	116.0	0.8 (1.76)

### 50 mm Offset-Machined

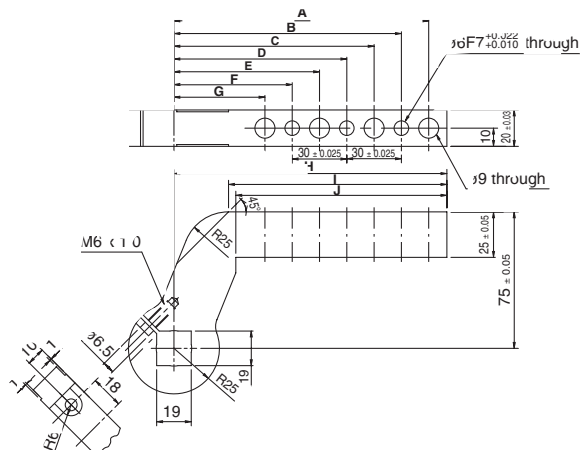

Part no.	NAAMS code	A	B	C	D	E	F	G	H	I	J	Weight kg (lbs)
CKZ-50A025	ACA256M	80.0	65.0	50.0	-	-	-	-	90.0	60.0	56.0	0.6 (1.32)
CKZ-50A026	ACA257M	110.0	95.0	80.0	65.0	50.0	-	-	120.0	90.0	86.0	0.7 (1.54)
CKZ-50A027	ACA258M	140.0	125.0	110.0	95.0	80.0	65.0	50.0	150.0	120.0	116.0	0.8 (1.76)

# Series CKZ2N

## Dimensions

### Arm / ø63 Straight-Plain

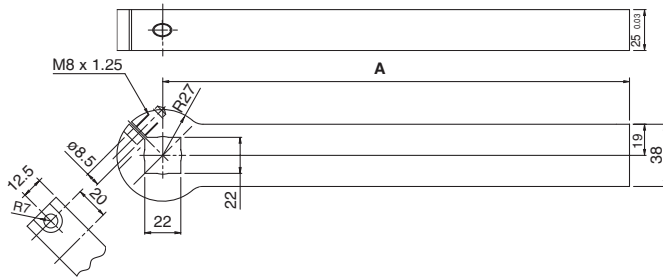

Part no.	NAAMS code	A	Weight kg (lbs)
CKZ-63A001	ACA001M	135.0	1.2 (2.64)
CKZ-63A002	ACA002M	165.0	1.4 (3.09)
CKZ-63A003	ACA003M	195.0	1.6 (3.53)
CKZ-63A004	ACA004M	225.0	1.8 (3.97)
CKZ-63A005	ACA005M	255.0	2.1 (4.63)
CKZ-63A006	ACA006M	285.0	2.3 (5.07)

### 20 mm Offset-Plain

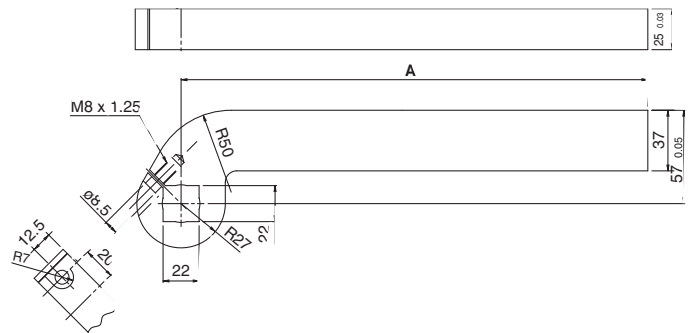

Part no.	NAAMS code	A	Weight kg (lbs)
CKZ-63A013	ACA013M	135.0	1.4 (3.09)
CKZ-63A014	ACA014M	165.0	1.6 (3.53)
CKZ-63A015	ACA015M	195.0	1.8 (3.97)
CKZ-63A016	ACA016M	225.0	2.0 (4.41)
CKZ-63A017	ACA017M	255.0	2.2 (4.85)
CKZ-63A018	ACA018M	285.0	2.4 (5.29)

### Straight-Machined

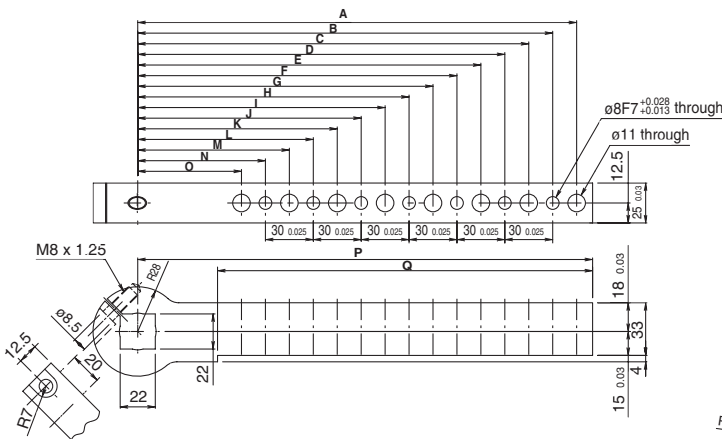

Part no.	NAAMS code	A	B	C	D	E	F	G	H	I	J	K	L	M
CKZ-63A007	ACA007M	125.0	110.0	95.0	80.0	65.0	-	-	-	-	-	-	-	-
CKZ-63A008	ACA008M	155.0	140.0	125.0	110.0	95.0	80.0	65.0	-	-	-	-	-	-
CKZ-63A009	ACA009M	185.0	170.0	155.0	140.0	125.0	110.0	95.0	80.0	65.0	-	-	-	-
CKZ-63A010	ACA010M	215.0	200.0	185.0	170.0	155.0	140.0	125.0	110.0	95.0	80.0	65.0	-	-
CKZ-63A011	ACA011M	245.0	230.0	215.0	200.0	185.0	170.0	155.0	140.0	125.0	110.0	95.0	80.0	65.0
CKZ-63A012	ACA012M	275.0	260.0	245.0	230.0	215.0	200.0	185.0	170.0	155.0	140.0	125.0	110.0	95.0

Part no.	NAAMS code	N	O	P	Q	Weight kg (lbs)
CKZ-63A007	ACA007M	-	-	135.0	85.0	1.0 (2.20)
CKZ-63A008	ACA008M	-	-	165.0	115.0	1.2 (2.64)
CKZ-63A009	ACA009M	-	-	195.0	145.0	1.4 (3.09)
CKZ-63A010	ACA010M	-	-	225.0	175.0	1.5 (3.31)
CKZ-63A011	ACA011M	-	-	255.0	205.0	1.7 (3.75)
CKZ-63A012	ACA012M	80.0	65.0	285.0	235.0	1.9 (4.19)

### 25 mm Offset-Machined

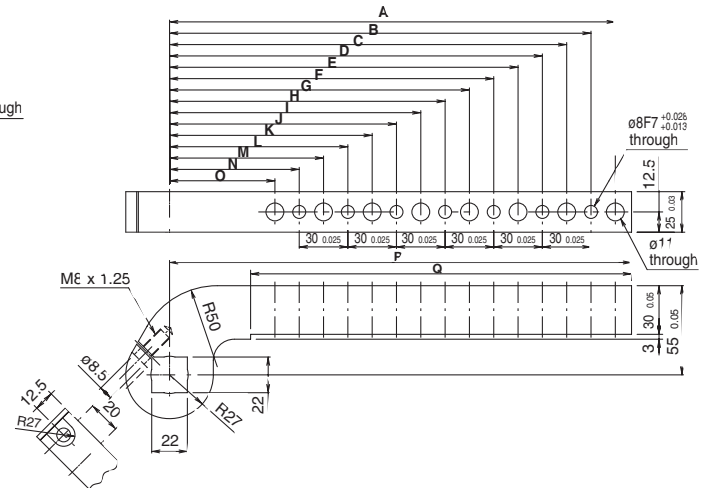

Part no.	NAAMS code	A	B	C	D	E	F	G	H	I	J	K	L	M
CKZ-63A019	ACA019M	125.0	110.0	95.0	80.0	65.0	-	-	-	-	-	-	-	-
CKZ-63A020	ACA020M	155.0	140.0	125.0	110.0	95.0	80.0	65.0	-	-	-	-	-	-
CKZ-63A021	ACA021M	185.0	170.0	155.0	140.0	125.0	110.0	95.0	80.0	65.0	-	-	-	-
CKZ-63A022	ACA022M	215.0	200.0	185.0	170.0	155.0	140.0	125.0	110.0	95.0	80.0	65.0	-	-
CKZ-63A023	ACA023M	245.0	230.0	215.0	200.0	185.0	170.0	155.0	140.0	125.0	110.0	95.0	80.0	65.0
CKZ-63A024	ACA024M	275.0	260.0	245.0	230.0	215.0	200.0	185.0	170.0	155.0	140.0	125.0	110.0	95.0

Part no.	NAAMS code	N	O	P	Q	Weight kg (lbs)
CKZ-63A019	ACA019M	-	-	135.0	85.0	1.3 (2.86)
CKZ-63A020	ACA020M	-	-	165.0	115.0	1.5 (3.31)
CKZ-63A021	ACA021M	-	-	195.0	145.0	1.6 (3.53)
CKZ-63A022	ACA022M	-	-	225.0	175.0	1.7 (3.75)
CKZ-63A023	ACA023M	-	-	255.0	205.0	1.9 (4.19)
CKZ-63A024	ACA024M	80.0	65.0	285.0	235.0	2.1 (4.63)

**65 mm Offset-Plain**

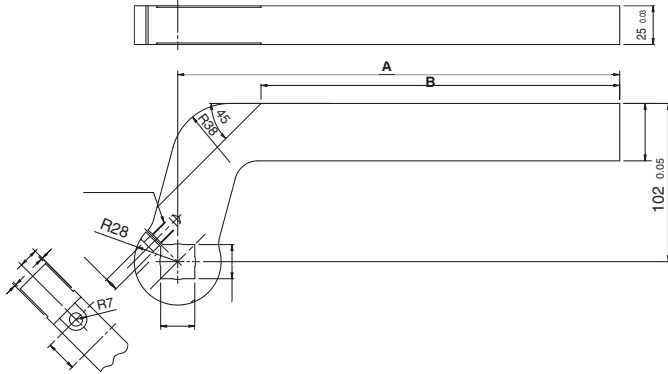

Part no.	NAAMS code	A	B	Weight kg (lbs)
CKZ-63A025	ACA025M	135.0	81.3	1.7 (3.75)
CKZ-63A026	ACA026M	165.0	111.3	1.9 (4.19)
CKZ-63A027	ACA027M	195.0	141.3	2.1 (4.63)
CKZ-63A028	ACA028M	225.0	171.3	2.3 (5.07)
CKZ-63A029	ACA029M	255.0	201.3	2.5 (5.51)
CKZ-63A030	ACA030M	285.0	231.3	2.7 (5.96)

**115 mm Offset-Plain**

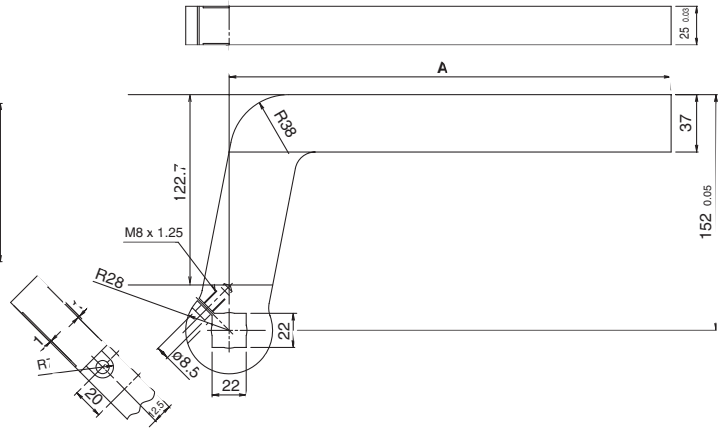

Part no.	NAAMS code	A	Weight kg (lbs)
CKZ-63A037	ACA037M	135.0	2.1 (4.63)
CKZ-63A038	ACA038M	165.0	2.3 (5.07)
CKZ-63A039	ACA039M	195.0	2.5 (5.51)
CKZ-63A040	ACA040M	225.0	2.7 (5.96)
CKZ-63A041	ACA041M	255.0	2.9 (6.40)
CKZ-63A042	ACA042M	285.0	3.1 (6.84)

**70 mm Offset-Machined**

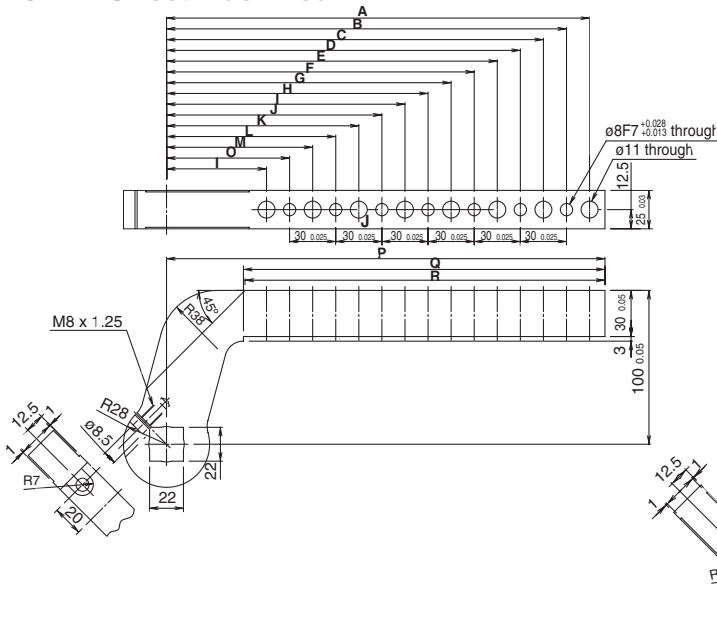

Part no.	NAAMS code	A	B	C	D	E	F	G	H	I	J	K	L	M
CKZ-63A031	ACA031M	125.0	110.0	95.0	80.0	65.0	-	-	-	-	-	-	-	-
CKZ-63A032	ACA032M	155.0	140.0	125.0	110.0	95.0	80.0	65.0	-	-	-	-	-	-
CKZ-63A033	ACA033M	185.0	170.0	155.0	140.0	125.0	110.0	95.0	80.0	65.0	-	-	-	-
CKZ-63A034	ACA034M	215.0	200.0	185.0	170.0	155.0	140.0	125.0	110.0	95.0	80.0	65.0	-	-
CKZ-63A035	ACA035M	245.0	230.0	215.0	200.0	185.0	170.0	155.0	140.0	125.0	110.0	95.0	80.0	65.0
CKZ-63A036	ACA036M	275.0	260.0	245.0	230.0	215.0	200.0	185.0	170.0	155.0	140.0	125.0	110.0	95.0

Part no.	NAAMS code	N	O	P	Q	R	Weight kg (lbs)
CKZ-63A031	ACA031M	-	-	135.0	85.0	84.0	1.4 (3.09)
CKZ-63A032	ACA032M	-	-	165.0	115.0	114.0	1.6 (3.53)
CKZ-63A033	ACA033M	-	-	195.0	145.0	144.0	1.8 (3.97)
CKZ-63A034	ACA034M	-	-	225.0	175.0	174.0	1.9 (4.19)
CKZ-63A035	ACA035M	-	-	255.0	205.0	204.0	2.1 (4.63)
CKZ-63A036	ACA036M	80.0	65.0	285.0	235.0	234.0	2.3 (5.07)

**120 mm Offset-Machined**

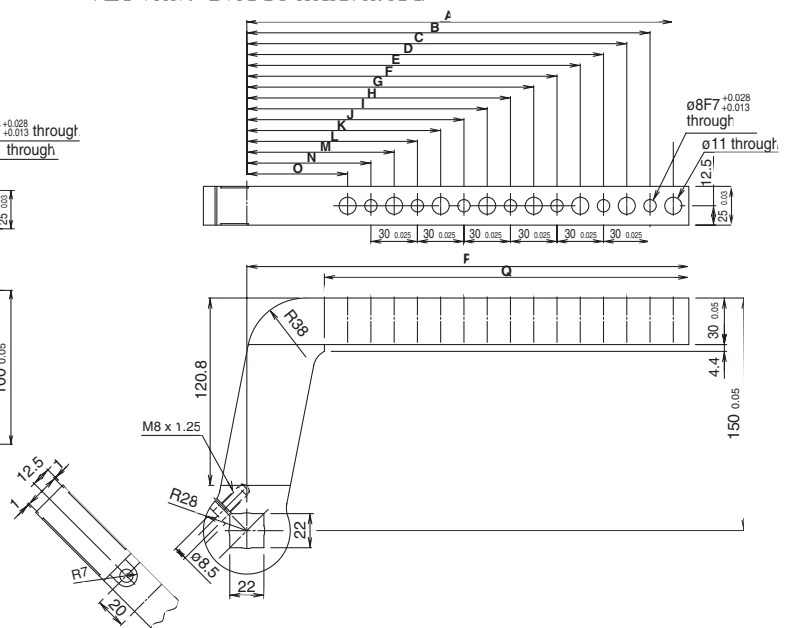

Part no.	NAAMS code	A	B	C	D	E	F	G	H	I	J	K	L	M
CKZ-63A043	ACA043M	125.0	110.0	95.0	80.0	65.0	-	-	-	-	-	-	-	-
CKZ-63A044	ACA044M	155.0	140.0	125.0	110.0	95.0	80.0	65.0	-	-	-	-	-	-
CKZ-63A045	ACA045M	185.0	170.0	155.0	140.0	125.0	110.0	95.0	80.0	65.0	-	-	-	-
CKZ-63A046	ACA046M	215.0	200.0	185.0	170.0	155.0	140.0	125.0	110.0	95.0	80.0	65.0	-	-
CKZ-63A047	ACA047M	245.0	230.0	215.0	200.0	185.0	170.0	155.0	140.0	125.0	110.0	95.0	80.0	65.0
CKZ-63A048	ACA048M	275.0	260.0	245.0	230.0	215.0	200.0	185.0	170.0	155.0	140.0	125.0	110.0	95.0

Part no.	NAAMS code	N	O	P	Q	Weight kg (lbs)
CKZ-63A043	ACA043M	-	-	135.0	85.0	1.8 (3.97)
CKZ-63A044	ACA044M	-	-	165.0	115.0	2.0 (4.41)
CKZ-63A045	ACA045M	-	-	195.0	145.0	2.1 (4.63)
CKZ-63A046	ACA046M	-	-	225.0	175.0	2.3 (5.07)
CKZ-63A047	ACA047M	-	-	255.0	205.0	2.5 (5.51)
CKZ-63A048	ACA048M	80.0	65.0	285.0	235.0	2.6 (5.73)

# Series CKZ2N

## Dimensions

### Arm / ø80 Straight-Plain

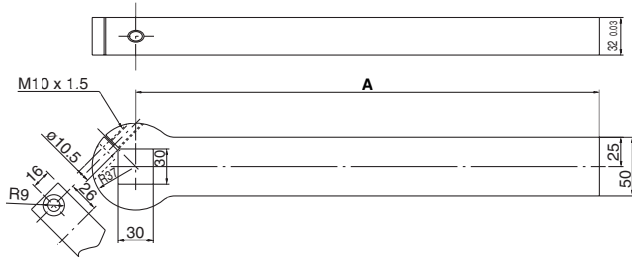

Part no.	NAAMS code	A	Weight kg (lbs)
CKZ-80A001	ACA100M	155.0	2.3 (5.07)
CKZ-80A002	ACA101M	185.0	2.7 (5.96)
CKZ-80A003	ACA102M	215.0	3.0 (6.62)
CKZ-80A004	ACA103M	245.0	3.4 (7.50)
CKZ-80A005	ACA104M	275.0	3.8 (8.38)
CKZ-80A006	ACA105M	305.0	4.2 (9.27)
CKZ-80A007	ACA106M	335.0	4.5 (9.93)
CKZ-80A008	ACA107M	365.0	4.9 (10.81)
CKZ-80A009	ACA108M	395.0	5.3 (11.69)

### 20 mm Offset-Plain

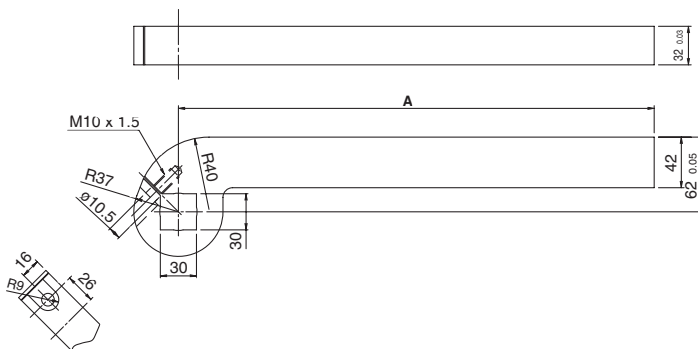

Part no.	NAAMS code	A	Weight kg (lbs)
CKZ-80A019	ACA120M	155.0	2.4 (5.29)
CKZ-80A020	ACA121M	185.0	2.7 (5.96)
CKZ-80A021	ACA122M	215.0	3.0 (6.62)
CKZ-80A022	ACA123M	245.0	3.3 (7.28)
CKZ-80A023	ACA124M	275.0	3.6 (7.94)
CKZ-80A024	ACA125M	305.0	3.9 (8.60)
CKZ-80A025	ACA126M	335.0	4.2 (9.27)
CKZ-80A026	ACA127M	365.0	4.6 (10.15)
CKZ-80A027	ACA128M	395.0	4.9 (10.81)



**Straight-Machined**

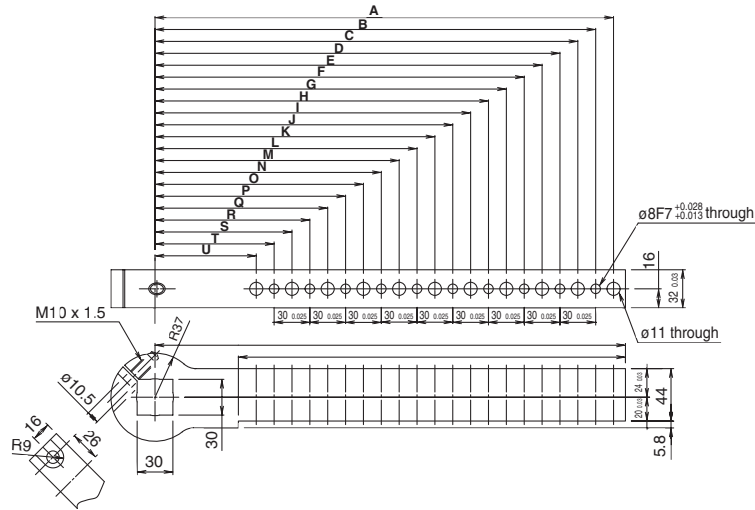

Part no.	NAAMS code	A	B	C	D	E	F	G	H	I	J	K	L	M	N	O	P	Q	R	S	T	U	V	W	Weight kg (lbs)	
CKZ-80A010	ACA110M	145.0	130.0	115.0	100.0	85.0	-	-	-	-	-	-	-	-	-	-	-	-	-	-	-	-	155.0	85.0	2.1 (4.63)	
CKZ-80A011	ACA111M	175.0	160.0	145.0	130.0	115.0	100.0	85.0	-	-	-	-	-	-	-	-	-	-	-	-	-	-	-	185.0	115.0	2.4 (5.29)
CKZ-80A012	ACA112M	205.0	190.0	175.0	160.0	145.0	130.0	115.0	100.0	85.0	-	-	-	-	-	-	-	-	-	-	-	-	-	215.0	145.0	2.7 (5.96)
CKZ-80A013	ACA113M	235.0	220.0	205.0	190.0	175.0	160.0	145.0	130.0	115.0	100.0	85.0	-	-	-	-	-	-	-	-	-	-	-	245.0	175.0	3.0 (6.62)
CKZ-80A014	ACA114M	265.0	250.0	235.0	220.0	205.0	190.0	175.0	160.0	145.0	130.0	115.0	100.0	85.0	-	-	-	-	-	-	-	-	-	275.0	205.0	3.3 (7.28)
CKZ-80A015	ACA115M	295.0	280.0	265.0	250.0	235.0	220.0	205.0	190.0	175.0	160.0	145.0	130.0	115.0	100.0	85.0	-	-	-	-	-	-	-	305.0	235.0	3.6 (7.94)
CKZ-80A016	ACA116M	325.0	310.0	295.0	280.0	265.0	250.0	235.0	220.0	205.0	190.0	175.0	160.0	145.0	130.0	115.0	100.0	85.0	-	-	-	-	-	335.0	265.0	3.9 (8.60)
CKZ-80A017	ACA117M	355.0	340.0	325.0	310.0	295.0	280.0	265.0	250.0	235.0	220.0	205.0	190.0	175.0	160.0	145.0	130.0	115.0	100.0	85.0	-	-	-	365.0	295.0	4.2 (9.27)
CKZ-80A018	ACA118M	385.0	370.0	355.0	340.0	325.0	310.0	295.0	280.0	265.0	250.0	235.0	220.0	205.0	190.0	175.0	160.0	145.0	130.0	115.0	100.0	85.0	395.0	325.0	4.5 (9.93)	

**25 mm Offset-Machined**

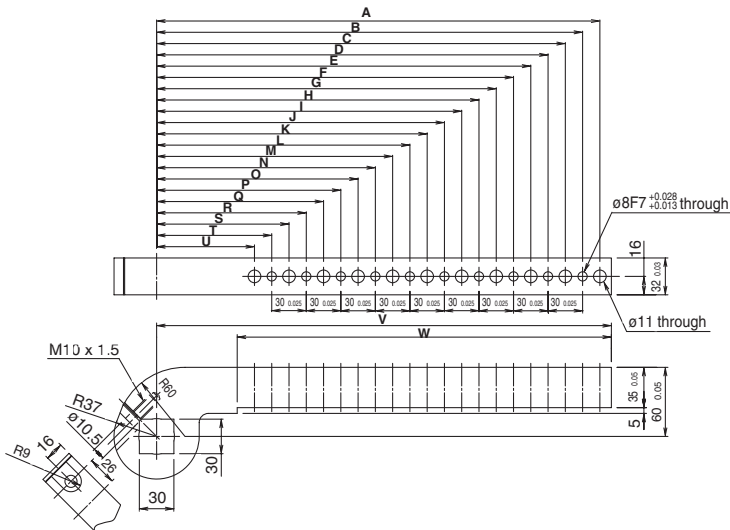

Part no.	NAAMS code	A	B	C	D	E	F	G	H	I	J	K	L	M	N	O	P	Q	R	S	T	U	V	W	Weight kg (lbs)
CKZ-80A028	ACA130M	145.0	130.0	115.0	100.0	85.0	-	-	-	-	-	-	-	-	-	-	-	-	-	-	-	-	155.0	85.0	2.1 (4.63)
CKZ-80A029	ACA131M	175.0	160.0	145.0	130.0	115.0	100.0	85.0	-	-	-	-	-	-	-	-	-	-	-	-	-	-	185.0	115.0	2.3 (5.07)
CKZ-80A030	ACA132M	205.0	190.0	175.0	160.0	145.0	130.0	115.0	100.0	85.0	-	-	-	-	-	-	-	-	-	-	-	-	215.0	145.0	2.6 (5.73)
CKZ-80A031	ACA133M	235.0	220.0	205.0	190.0	175.0	160.0	145.0	130.0	115.0	100.0	85.0	-	-	-	-	-	-	-	-	-	-	245.0	175.0	2.8 (6.18)
CKZ-80A032	ACA134M	265.0	250.0	235.0	220.0	205.0	190.0	175.0	160.0	145.0	130.0	115.0	100.0	85.0	-	-	-	-	-	-	-	-	275.0	205.0	3.0 (6.62)
CKZ-80A033	ACA135M	295.0	280.0	265.0	250.0	235.0	220.0	205.0	190.0	175.0	160.0	145.0	130.0	115.0	100.0	85.0	-	-	-	-	-	-	305.0	235.0	3.2 (7.06)
CKZ-80A034	ACA136M	325.0	310.0	295.0	280.0	265.0	250.0	235.0	220.0	205.0	190.0	175.0	160.0	145.0	130.0	115.0	100.0	85.0	-	-	-	-	335.0	265.0	3.5 (7.72)
CKZ-80A035	ACA137M	355.0	340.0	325.0	310.0	295.0	280.0	265.0	250.0	235.0	220.0	205.0	190.0	175.0	160.0	145.0	130.0	115.0	100.0	85.0	-	-	365.0	295.0	3.8 (8.38)
CKZ-80A036	ACA138M	385.0	370.0	355.0	340.0	325.0	310.0	295.0	280.0	265.0	250.0	235.0	220.0	205.0	190.0	175.0	160.0	145.0	130.0	115.0	100.0	85.0	395.0	325.0	4.0 (8.83)

# Series CKZ2N

## Dimensions

### 65 mm Offset-Plain

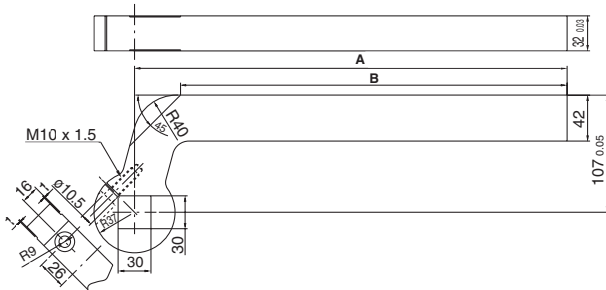

Part no.	NAAMS code	A	B	Weight kg (lbs)
CKZ-80A037	ACA140M	155.0	113.0	2.7 (5.96)
CKZ-80A038	ACA141M	185.0	143.0	3.0 (6.62)
CKZ-80A039	ACA142M	215.0	173.0	3.3 (7.28)
CKZ-80A040	ACA143M	245.0	203.0	3.6 (7.94)
CKZ-80A041	ACA144M	275.0	233.0	3.9 (8.60)
CKZ-80A042	ACA145M	305.0	263.0	4.2 (9.27)
CKZ-80A043	ACA146M	335.0	293.0	4.5 (9.93)
CKZ-80A044	ACA147M	365.0	323.0	4.8 (10.59)
CKZ-80A045	ACA148M	395.0	353.0	5.1 (11.25)

### 115 mm Offset-Plain

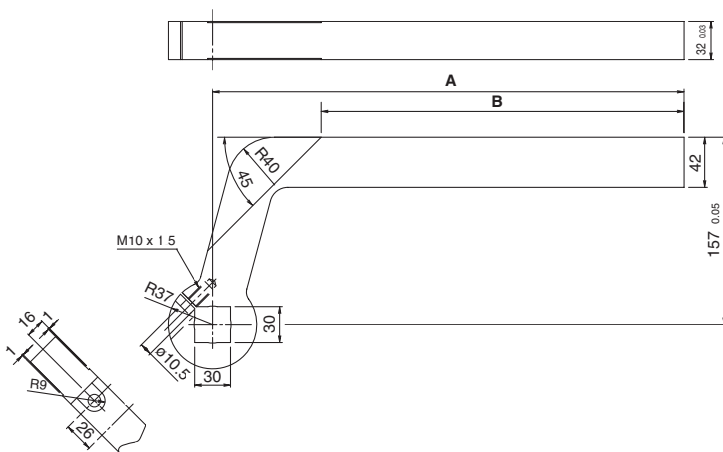

Part no.	NAAMS code	A	B	Weight kg (lbs)
CKZ-80A055	ACA160M	155.0	64.0	3.0 (6.62)
CKZ-80A056	ACA161M	185.0	94.0	3.3 (7.28)
CKZ-80A057	ACA162M	215.0	124.0	3.6 (7.94)
CKZ-80A058	ACA163M	245.0	154.0	3.9 (8.60)
CKZ-80A059	ACA164M	275.0	184.0	4.2 (9.27)
CKZ-80A060	ACA165M	305.0	214.0	4.5 (9.93)
CKZ-80A061	ACA166M	335.0	244.0	4.8 (10.59)
CKZ-80A062	ACA167M	365.0	274.0	5.2 (11.47)
CKZ-80A063	ACA168M	395.0	304.0	5.5 (12.14)

**70 mm Offset-Machined**

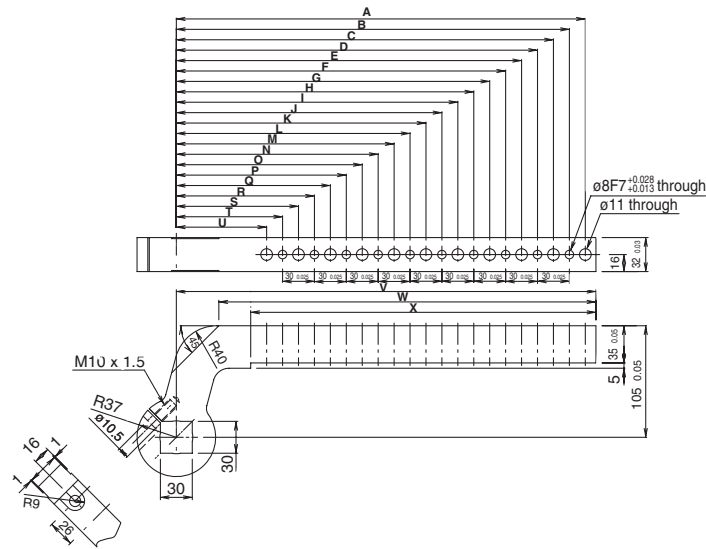

Part no.	NAAMS code	A	B	C	D	E	F	G	H	I	J	K	L	M	N	O	P	Q	R	S	T	U	V	W	X	Weight kg (lbs)	
CKZ-80A046	ACA150M	145.0	130.0	115.0	100.0	85.0	-	-	-	-	-	-	-	-	-	-	-	-	-	-	-	-	155.0	115.0	85.0	2.4 (5.29)	
CKZ-80A047	ACA151M	175.0	160.0	145.0	130.0	115.0	100.0	85.0	-	-	-	-	-	-	-	-	-	-	-	-	-	-	-	185.0	145.0	115.0	2.6 (5.73)
CKZ-80A048	ACA152M	205.0	190.0	175.0	160.0	145.0	130.0	115.0	100.0	85.0	-	-	-	-	-	-	-	-	-	-	-	-	-	215.0	175.0	145.0	2.8 (6.18)
CKZ-80A049	ACA153M	235.0	220.0	205.0	190.0	175.0	160.0	145.0	130.0	115.0	100.0	85.0	-	-	-	-	-	-	-	-	-	-	-	245.0	205.0	175.0	3.1 (6.84)
CKZ-80A050	ACA154M	265.0	250.0	235.0	220.0	205.0	190.0	175.0	160.0	145.0	130.0	115.0	100.0	85.0	-	-	-	-	-	-	-	-	-	275.0	235.0	205.0	3.3 (7.28)
CKZ-80A051	ACA155M	295.0	280.0	265.0	250.0	235.0	220.0	205.0	190.0	175.0	160.0	145.0	130.0	115.0	100.0	85.0	-	-	-	-	-	-	-	305.0	265.0	235.0	3.5 (7.72)
CKZ-80A052	ACA156M	325.0	310.0	295.0	280.0	265.0	250.0	235.0	220.0	205.0	190.0	175.0	160.0	145.0	130.0	115.0	100.0	85.0	-	-	-	-	-	335.0	295.0	265.0	3.8 (8.38)
CKZ-80A053	ACA157M	355.0	340.0	325.0	310.0	295.0	280.0	265.0	250.0	235.0	220.0	205.0	190.0	175.0	160.0	145.0	130.0	115.0	100.0	85.0	-	-	-	365.0	325.0	295.0	4.0 (8.83)
CKZ-80A054	ACA158M	385.0	370.0	355.0	340.0	325.0	310.0	295.0	280.0	265.0	250.0	235.0	220.0	205.0	190.0	175.0	160.0	145.0	130.0	115.0	100.0	85.0	395.0	355.0	325.0	4.3 (9.49)	

**120 mm Offset-Machined**

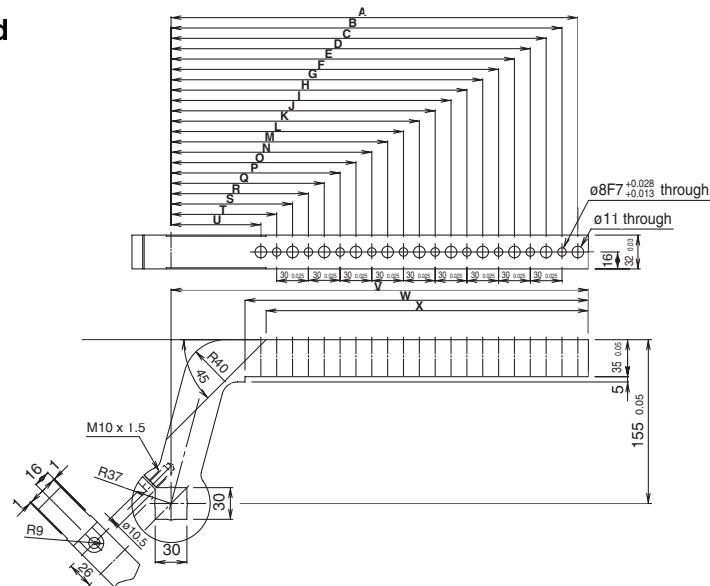

Part no.	NAAMS code	A	B	C	D	E	F	G	H	I	J	K	L	M	N	O	P	Q	R	S	T	U	V	W	X	Weight kg (lbs)	
CKZ-80A064	ACA170M	145.0	130.0	115.0	100.0	85.0	-	-	-	-	-	-	-	-	-	-	-	-	-	-	-	-	155.0	85.0	65.0	2.7 (5.96)	
CKZ-80A065	ACA171M	175.0	160.0	145.0	130.0	115.0	100.0	85.0	-	-	-	-	-	-	-	-	-	-	-	-	-	-	-	185.0	115.0	95.0	2.9 (6.40)
CKZ-80A066	ACA172M	205.0	190.0	175.0	160.0	145.0	130.0	115.0	100.0	85.0	-	-	-	-	-	-	-	-	-	-	-	-	-	215.0	145.0	125.0	3.2 (7.06)
CKZ-80A067	ACA173M	235.0	220.0	205.0	190.0	175.0	160.0	145.0	130.0	115.0	100.0	85.0	-	-	-	-	-	-	-	-	-	-	-	245.0	175.0	155.0	3.4 (7.50)
CKZ-80A068	ACA174M	265.0	250.0	235.0	220.0	205.0	190.0	175.0	160.0	145.0	130.0	115.0	100.0	85.0	-	-	-	-	-	-	-	-	-	275.0	205.0	185.0	3.6 (7.94)
CKZ-80A069	ACA175M	295.0	280.0	265.0	250.0	235.0	220.0	205.0	190.0	175.0	160.0	145.0	130.0	115.0	100.0	85.0	-	-	-	-	-	-	-	305.0	235.0	215.0	3.9 (8.60)
CKZ-80A070	ACA176M	325.0	310.0	295.0	280.0	265.0	250.0	235.0	220.0	205.0	190.0	175.0	160.0	145.0	130.0	115.0	100.0	85.0	-	-	-	-	-	335.0	265.0	245.0	4.1 (9.05)
CKZ-80A071	ACA177M	355.0	340.0	325.0	310.0	295.0	280.0	265.0	250.0	235.0	220.0	205.0	190.0	175.0	160.0	145.0	130.0	115.0	100.0	85.0	-	-	-	365.0	295.0	275.0	4.4 (9.71)
CKZ-80A072	ACA178M	385.0	370.0	355.0	340.0	325.0	310.0	295.0	280.0	265.0	250.0	235.0	220.0	205.0	190.0	175.0	160.0	145.0	130.0	115.0	100.0	85.0	395.0	325.0	305.0	4.6 (10.15)	





Series **CKZ2N**

# Safety Instructions

These safety instructions are intended to prevent a hazardous situation and/or equipment damage. These instructions indicate the level of potential hazard by a label of "**Caution**", "**Warning**" or "**Danger**". To ensure safety, be sure to observe ISO 4414 Note 1), JIS B 8370 Note 2) and other safety practices.

 **Caution :** Operator error could result in injury or equipment damage.

 **Warning :** Operator error could result in serious injury or loss of life.

 **Danger :** In extreme conditions, there is a possible result of serious injury or loss of life.

Note 1) ISO 4414: Pneumatic fluid power -- Recommendations for the application of equipment to transmission and control systems.

Note 2) JIS B 8370: General Rules for Pneumatic Equipment

## Warning

### **1. The compatibility of pneumatic equipment is the responsibility of the person who designs the pneumatic system or decides its specifications.**

Since the products specified here are used in various operating conditions, their compatibility for the specific pneumatic system must be based on specifications or after analysis and/or tests to meet your specific requirements.

### **2. Only trained personnel should operate pneumatically operated machinery and equipment.**

Compressed air can be dangerous if an operator is unfamiliar with it. Assembly, handling or repair of pneumatic systems should be performed by trained and experienced operators.

### **3. Do not service machinery/equipment or attempt to remove components until safety is confirmed.**

1. Inspection and maintenance of machinery/equipment should only be performed after confirmation of safe locked-out control positions.
2. When equipment is to be removed, confirm the safety process as mentioned above. Cut the supply pressure for this equipment and exhaust all residual compressed air in the system.
3. Before machinery/equipment is restarted, take measures to prevent shooting-out of cylinder piston rod, etc. (Bleed air into the system gradually to create back pressure.)

### **4. Contact SMC if the product is to be used in any of the following conditions:**

1. Conditions and environments beyond the given specifications, or if product is used outdoors.
2. Installation on equipment in conjunction with atomic energy, railway, air navigation, vehicles, medical equipment, food and beverages, recreation equipment, emergency stop circuits, press applications, or safety equipment.
3. An application which has the possibility of having negative effects on people, property, or animals, requiring special safety analysis.



## Series CKZ2N

# Actuator Precautions 1

Be sure to read this before handling.

### Design

#### Warning

- 1. There is a danger of sudden action by air cylinders if sliding parts of machinery are twisted, etc., and changes in forces occur.**

In such cases, human injury may occur; e.g., by catching hands or feet in the machinery, or damage to the machinery itself may occur. Therefore, the machine should be designed to avoid such dangers.

- 2. Attach a protective cover to minimize the risk of human injury.**

If a driven object and moving parts of a cylinder pose a danger of human injury, design the structure to avoid contact with the human body.

- 3. Securely tighten all stationary parts and connected parts so that they will not become loose.**

Especially when a cylinder operates with high frequency or is installed where there is a lot of vibration, ensure that all parts remain secure.

- 4. A deceleration circuit or shock absorber, etc., may be required.**

When a driven object is operated at high speed or the load is heavy, a cylinder's cushion will not be sufficient to absorb the impact. Install a deceleration circuit to reduce the speed before cushioning, or install an external shock absorber to relieve the impact. In this case, the rigidity of the machinery should also be examined.

- 5. Consider a possible drop in circuit pressure due to a power outage, etc.**

When a cylinder is used in a clamping mechanism, there is a danger of work pieces dropping if there is a decrease in clamping force due to a drop in circuit pressure caused by a power outage, etc. Therefore, safety equipment should be installed to prevent damage to machinery and/or human injury. Suspension mechanisms and lifting devices also require consideration for drop prevention.

- 6. Consider a possible loss of power source.**

Measures should be taken to protect against human injury and equipment damage in the event that there is a loss of power to equipment controlled by air pressure, electricity or hydraulics, etc.

- 7. Design circuitry to prevent sudden lurching of driven objects.**

When a cylinder is driven by an exhaust center type directional control valve or when starting up after residual pressure is exhausted from the circuit, etc., the piston and its driven object will lurch at high speed if pressure is applied to one side of the cylinder because of the absence of air pressure inside the cylinder. Therefore, equipment should be selected and circuits designed to prevent sudden lurching because, there is a danger of human injury and/or damage to equipment when this occurs.

- 8. Consider emergency stops.**

Design so that human injury and/or damage to machinery and equipment will not be caused when machinery is stopped by a safety device under abnormal conditions, a power outage or a manual emergency stop.

- 9. Consider the action when operation is restarted after an emergency stop or abnormal stop.**

Design the machinery so that human injury or equipment damage will not occur upon restart of operation. When the cylinder has to be reset at the starting position, install safe manual control equipment.

### Selection

#### Warning

- 1. Confirm the specifications.**

The products advertised in this catalog are designed according to use in industrial compressed air systems. If the products are used in conditions where pressure, temperature, etc., are out of specification, damage and/or malfunction may be caused. Do not use in these conditions. (Refer to specifications.)

Consult SMC if you use a fluid other than compressed air.

#### Caution

- 1. Operate the piston within a range such that collision damage will not occur at the stroke end.**

Operate within a range such that damage will not occur when the piston having inertial force stops by striking the cover at the stroke end. Refer to the cylinder model selection procedure for the range within which damage will not occur.

- 2. Use a speed controller to adjust the cylinder drive speed, gradually increasing from a low speed to the desired speed setting.**

### Mounting

#### Caution

- 1. Do not scratch or gouge the sliding parts of the cylinder tube or piston rod, etc., by striking or grasping them with other objects.**

Cylinder bores are manufactured to precise tolerances, so that even a slight deformation may cause malfunction. Also, scratches or gouges, etc., in the piston rod may lead to damaged seals and cause air leakage.

- 2. Do not use until you can verify that equipment can operate properly.**

Following mounting, maintenance or conversions, verify correct mounting by suitable function and leakage tests after compressed air and power are connected.



# Series CKZ2N Actuator Precautions 2

Be sure to read this before handling.

## Piping

### Caution

#### 1 Preparation before piping

Before piping is connected, it should be thoroughly blown out with air (flushing) or washed to remove chips, cutting oil and other debris from inside the pipe.

#### 2. Wrapping of pipe tape

When screwing together pipes and fittings, etc., be certain that chips from the pipe threads and sealing material do not get inside the piping.

Also, when pipe tape is used, leave 1.5 to 2 thread ridges exposed at the end of the threads.

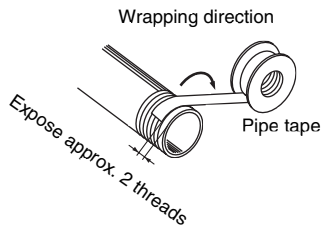

## Lubrication

### Caution

#### 1 Lubrication on cylinder

The cylinder has been lubricated for life at the factory and can be used without any further lubrication.

However, in the event that it will be lubricated, use class 1 turbine oil (with no additives) ISO VG32.

Stopping lubrication later may lead to malfunction due to the loss of the original lubricant. Therefore, lubrication must be continued once it has been started.

## Air Supply

### Warning

#### 1 Use clean air.

Do not use compressed air that includes chemicals, synthetic oils containing organic solvents, salt or corrosive gases, etc., as it can cause damage or malfunction.

## Air Supply

### Caution

#### 1 Install air filters.

Install air filters at the upstream side of valves. The filtration degree should be 5 μm or finer.

#### 2. Install an after-cooler, air dryer or water separator etc.

Air that includes excessive drainage may cause malfunction of valves and other pneumatic equipment. To prevent this, install an after-cooler, air dryer or water separator, etc.

#### 3. Use the product within the specified range of fluid and ambient temperature.

Take measures to prevent freezing, since moisture in circuits can be frozen below 5°C, and this may cause damage to seals and lead to malfunction.

Refer to SMC Best Pneumatics 2004 Vol. 14 catalog for further details on compressed air quality.

## Operating Environment

### Warning

#### 1 Do not use in environments where there is a danger of corrosion.

## Maintenance

### Caution

#### 1 Drain flushing

Remove drainage from air filters regularly (Refer to specifications.)



# Series CKZ2N Specific Product Precautions

Be sure to read this before handling. Refer to the back of pages 1 through to 3 for Safety Instructions and Actuator Precautions.

## 1 Manual toggle release

The toggle link mechanism can be released easily by hitting the portion of round shaped projection on the cover by using of plastic hammer (hammer made of soft material), etc.

Please be sure to perform manual toggle release after safety has been confirmed because the clamp arm can suddenly move up moving during manual release.

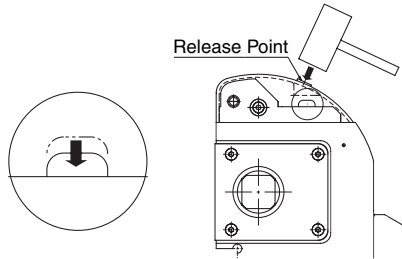

- Note:** (1) Please make sure that the switch cassette is tightly secured to the body when it has been replaced with a new one.  
(2) Please make sure that the switch actuator is mounted so that the stamped side is secured as shown below if replacing

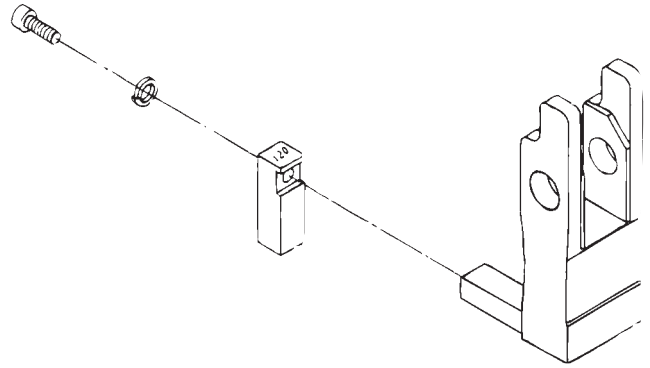

## 2. Do not disassemble the power clamp.

No special maintenance is necessary because the power clamp has a fully enclosed design to protect the clamp against welding spatter, and also the power clamp has a contamination resistant construction. So, please do not disassemble the power clamp except changing replaceable parts as there is a possibility of deterioration of the clamp performance.

## 3. Tightening torque of spare parts

Please make sure to tighten spare parts recommended in accordance with the following torque shown in the table.

Description	Bore size (mm)	Tightening torque	
		N•m	lbf•in
Switch cassette kit	50	5.0 to 7.0	44 to 62
	63	5.0 to 7.0	44 to 62
	80	5.0 to 7.0	44 to 62
Switch bracket kit	50	3.0 to 4.0	27 to 35
	63	3.0 to 4.0	27 to 35
	80	3.0 to 4.0	27 to 35
Stopper bolt kit	50	130 to 150	1150 to 1327
	63	160 to 200	1416 to 1770
	80	480 to 520	4248 to 4600
Top cover kit	50	2.5 to 3.0	22 to 27
	63	2.5 to 3.0	22 to 27
	80	3.0 to 5.0	27 to 44

## 4. Clamp Arm Tightening Torque

Bore size (mm)	Tightening torque	
	N•m	lbf•in
50	12 to 15	106 to 133
63	15 to 20	133 to 177
80	18 to 24	159 to 212





## SMC'S GLOBAL MANUFACTURING, DISTRIBUTION AND SERVICE NETWORK

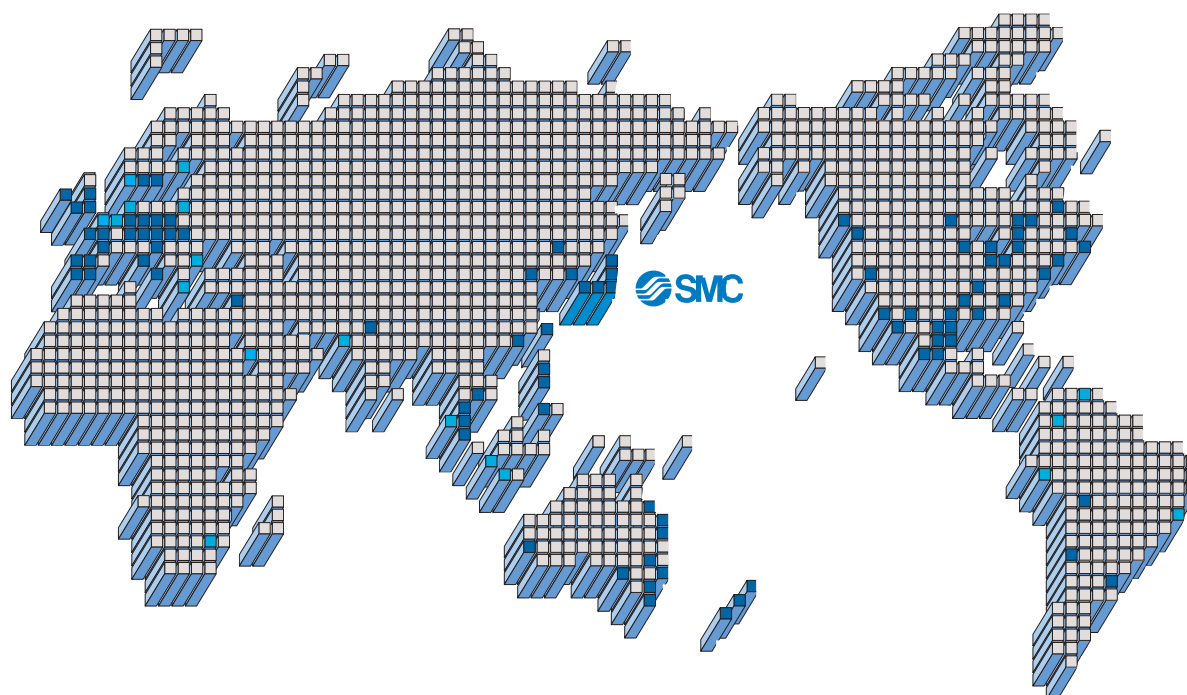

### EUROPE

#### AUSTRIA

SMC Pneumatik GmbH

#### BELGIUM

SMC Pneumatics N.V./S.A.

#### BULGARIA

SMC Industrial Automation Bulgaria EOOD

#### CROATIA

SMC Industrijska automatika d.o.o.

#### CZECH REPUBLIC

SMC Industrial Automation CZ s.r.o.

#### DENMARK

SMC Pneumatik A/S

#### ESTONIA

SMC Pneumatics Estonia OÜ

#### FINLAND

SMC Pneumatics Finland OY

#### FRANCE

SMC Pneumatique SA

#### GERMANY

SMC Pneumatik GmbH

#### HUNGARY

SMC Hungary Ipari Automatizálási Kft.

#### IRELAND

SMC Pneumatics (Ireland) Ltd.

#### ITALY

SMC Italia S.p.A.

#### LATVIA

SMC Pneumatics Latvia SIA

#### LITHUANIA

SMC Pneumatics Lietuva, UAB

#### NETHERLANDS

SMC Pneumatics BV

### NORWAY

SMC Pneumatics Norway A/S

### POLAND

SMC Industrial Automation Polska Sp.z.c.o

### ROMANIA

SMC Romania s.r.l.

### RUSSIA

SMC Pneumatik LLC.

### SLOVAKIA

SMC Priemyselna automatizacia s.r.o

### SLOVENIA

SMC INDUSTRIJSKA AVTOMATIKA d.o.o

### SPAIN/PORTUGAL

SMC España, S.A.

### SWEDEN

SMC Pneumatics Sweder AB

### SWITZERLAND

SMC Pneumatik AG

### UK

SMC Pneumatics (U.K.) Ltd.

### ASIA

#### CHINA

SMC (China) Co., Ltd.

#### HONG KONG

SMC Pneumatics (Hong Kong) Ltd

#### INDIA

SMC Pneumatics (India) Pvt. Ltd.

#### INDONESIA

PT SMC Pneumatics Indonesia

#### MALAYSIA

SMC Pneumatics (S.E.A.) Sdn. Bhd.

#### PHILIPPINES

SHOKETSU-SMC Corporation

### SINGAPORE

SMC Pneumatics (S.E.A.) Pte. Ltd.

### SOUTH KOREA

SMC Pneumatics Korea Co., Ltd.

### TAIWAN

SMC Pneumatics (Taiwan) Co., Ltd.

### THAILAND

SMC Thailand Ltd

### NORTH AMERICA

#### CANADA

SMC Pneumatics (Canada) Ltd.

#### MEXICO

SMC Corporation (Mexico) S.A. de C.V.

#### USA

SMC Corporation of America

### SOUTH AMERICA

#### ARGENTINA

SMC Argentina S.A

#### BOLIVIA

SMC Pneumatics Bolivia S.R.L.

#### BRAZIL

SMC Pneumaticos Do Brazil Ltda.

#### CHILE

SMC Pneumatics (Chile) S.A.

#### VENEZUELA

SMC Neumatica Venezuela S.A

### OCEANIA

#### AUSTRALIA

SMC Pneumatics (Australia) Pty. Ltd.

#### NEW ZEALAND

SMC Pneumatics (N.Z.) Ltd.

## SMC Corporation

Akihabara UDX 15F,  
4-14-1, Sotokanda, Chiyoda-ku, Tokyo 101-0021, JAPAN  
Phone: 03-5207-8249 FAX: 03-5298-5362  
URL <http://www.smcworld.com>  
© 2006 SMC Corporation All Rights Reserved

Specifications are subject to change without prior notice  
and any obligation on the part of the manufacturer.

D-DN

1st printing KC printing KQ 120DN Printed in Japan.

This catalog is printed on recycled paper with concern for the global environment.