

Multistage Ejector

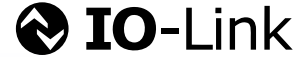

Only for the models with a valve or pressure switch
The ZL1 with an AC voltage valve is not compliant.



Max. suction flow rate

3 types available:
100, 300, and 600 L/min (ANR)

New

Suction: 300 L	Suction: 600 L
ZL3	ZL6

- An M12 connector (IP65 specification) has been added.



Max. suction flow rate: 600 L/min (ANR)	*2
Air consumption: 270 L/min (ANR)	*1

ZL6 Series p. 21



Air consumption

Suction: 300 L
ZL3
Suction: 600 L
ZL6

91% reduction

(Under SMC's measurement conditions)

Reduced by the pressure switch for vacuum with energy saving function and efficient ejectors

Suction: 100 L
ZL1

10% reduction

Reduction due to improved ejector efficiency (Comparison with the previous ZL112)

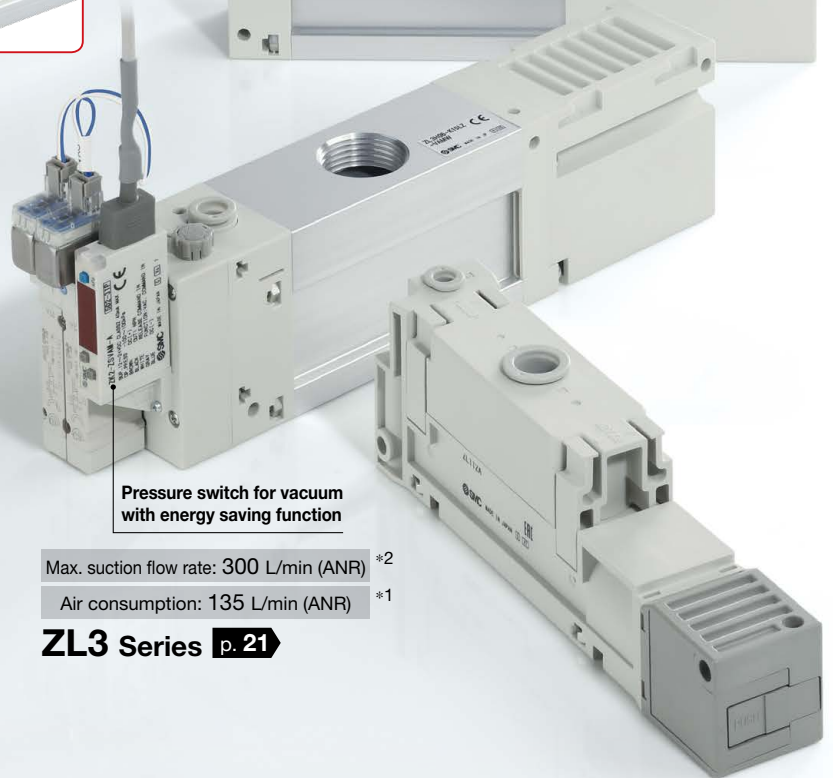

Pressure switch for vacuum with energy saving function

Max. suction flow rate: 300 L/min (ANR)	*2
Air consumption: 135 L/min (ANR)	*1

ZL3 Series p. 21

Weight

Suction: 300 L
ZL3
Suction: 600 L
ZL6

Max. **44% reduction**

ZL212 (Previous model): 700 g → ZL3: **390 g**

Suction: 100 L
ZL1

Max. **60% reduction**

ZL112 (Previous model): 450 g → ZL1: **180 g**

Max. suction flow rate: 100 L/min (ANR)

Air consumption: 57 L/min (ANR)

ZL1 Series p. 9

*1 ZL3H, ZL6H (Standard supply pressure: 0.5 MPa)
*2 Branch + Port exhaust

ZL1/ZL3/ZL6 Series



CAT.ES100-108E

Energy saving

ZL3

ZL6

Air consumption

91% reduction *1, *2

*1 Under SMC's measurement conditions.

*2 Reduced by the pressure switch for vacuum with energy saving function and efficient ejectors

Pressure switch for vacuum with energy saving function

Air consumption 90% reduction

More efficient ejector

Air consumption 10% reduction
(Compared to ZL212)

New

M12 connector/IP65
Pressure switch for vacuum with energy saving function

ZL3/ZL6

When the suction signal is ON, the ON/OFF operation of the supply valve is performed automatically within the set value by the pressure switch for vacuum with energy saving function.

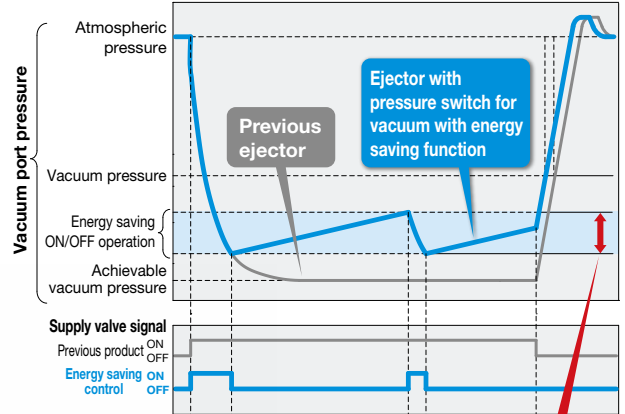

ON/OFF operation can be set with any set value.

Energy saving efficiency: 91% reduction

Power consumption cost per year reduced by **15,356 JPY/year** *1

Energy saving function

More efficient ejector

	Power consumption cost per year	Annual air consumption	Exhaust time	Air consumption
ZL3/With energy saving function	1,519 JPY/year	1,013 m ³ /year	1.5 s	135 L/min (ANR)
Previous product (ZL212)	16,875 JPY/year	11,250 m ³ /year	15 s	150 L/min (ANR)

*1 **Cost conditions** · Air unit 1.5 JPY/m³ (ANR), Annual operating cycles: 300000
(Operating hours: 10 hours/day, Operating days: 250 days/year, 120 cycles/h, when 1 unit is used)

High efficiency (Suction flow rate/Air consumption)

ZL1

ZL3

ZL6

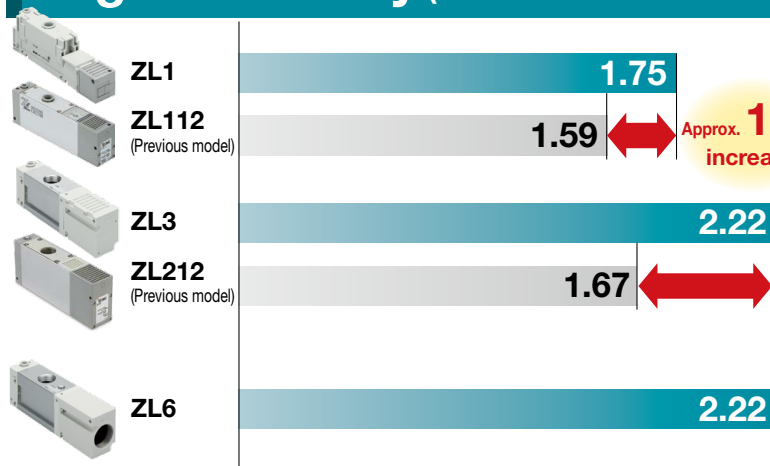

	Max. suction flow rate	Air consumption	Efficiency
ZL1	100	57	1.75
ZL112	100	63	1.59
ZL3	300	135	2.22
ZL212	250	150	1.67
ZL6	600	270	2.22

* ZL1 (Standard supply pressure: 0.33 MPa)
* ZL3H (Standard supply pressure: 0.5 MPa)

3-stage diffuser construction

ZL1 ZL3 ZL6

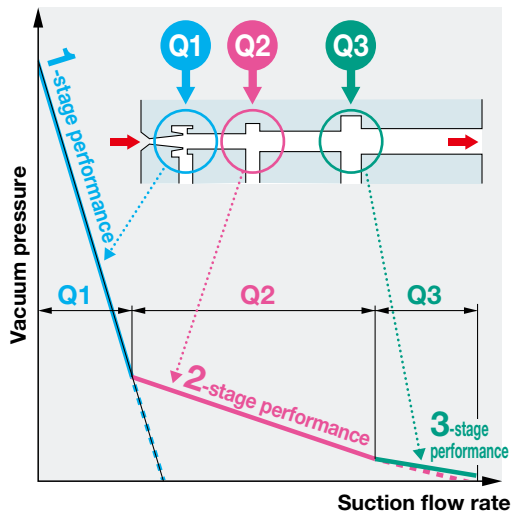

ZL1/ZL3

Max. suction flow rate **100/300 L/min (ANR)**

Suction flow rate increased by 250%

(SMC comparison with the ZL1: 1-stage $\phi 1.3$ nozzle, suction flow rate of 40 L/min (ANR))

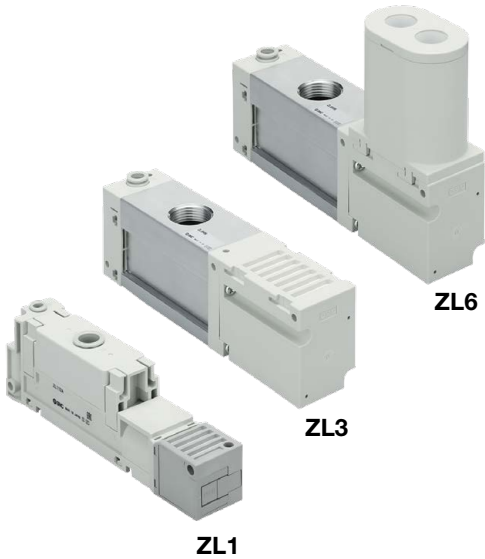
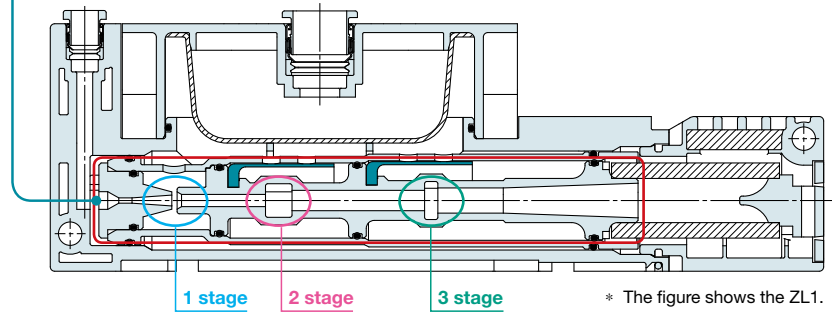

ZL6

Max. suction flow rate **600 L/min (ANR)*1**
570 L/min (ANR)*2

*1 Branch + Port exhaust
*2 With a silencer attached

Compact with a large flow rate and 2 built-in ejector assemblies

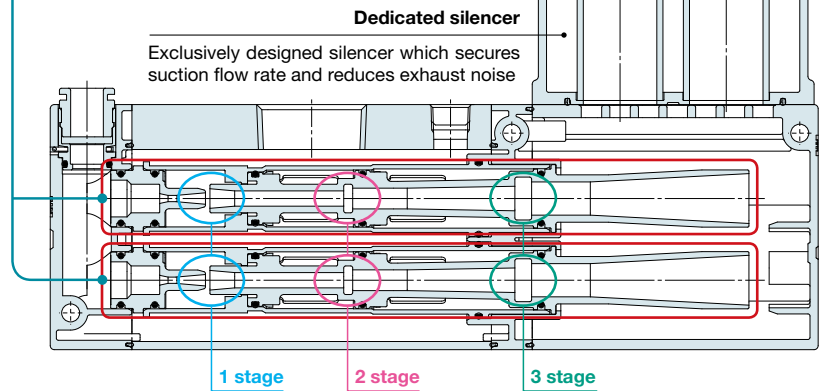

Applications

■ For the adsorption transfer of glass for automobiles

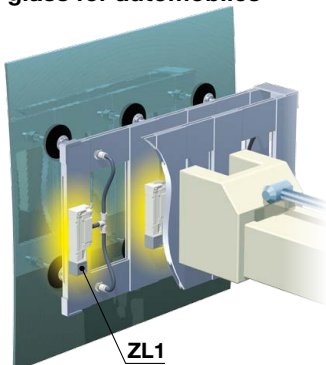

■ For the adsorption (clamping) of workpieces

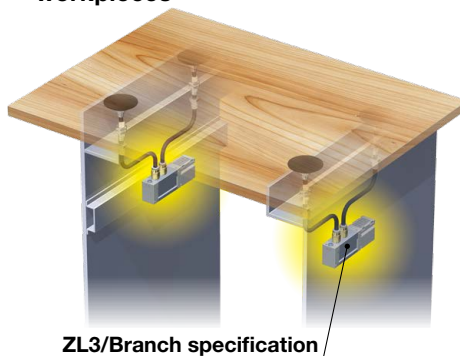

■ For the adsorption transfer of cardboard

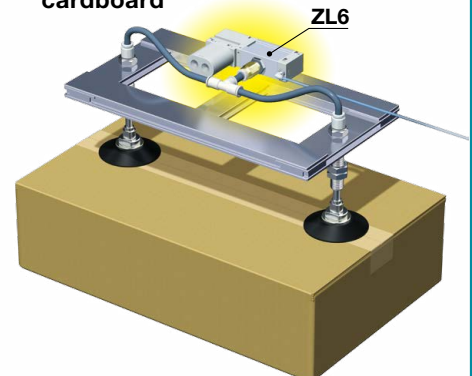

Various vacuum pressure sensors

ZL1

ZL3

ZL6

1 With vacuum pressure switch

- Vacuum pressure switch (Vacuum 2 outputs)
- Vacuum pressure switch (Compound pressure 2 outputs)
- Pressure switch for vacuum with energy saving function (Compound pressure 1 output)

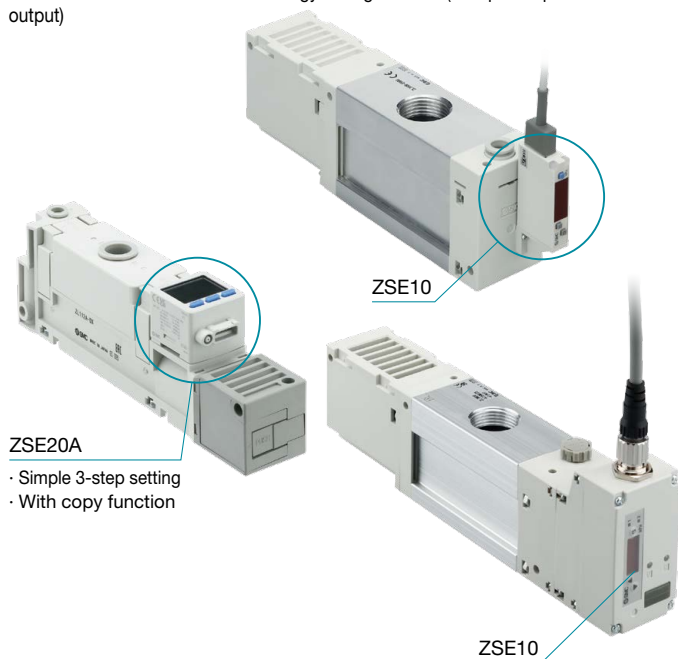

- ZSE20A**
- Simple 3-step setting
 - With copy function

2 With pressure gauge

- Pressure range:
 - 100 to 100 kPa (When the port is metric spec.)
 - 30 inHg to 14 psi (When the port is inch spec.)



3 With vacuum pressure detection port * Only applicable to the ZL1 and ZL3

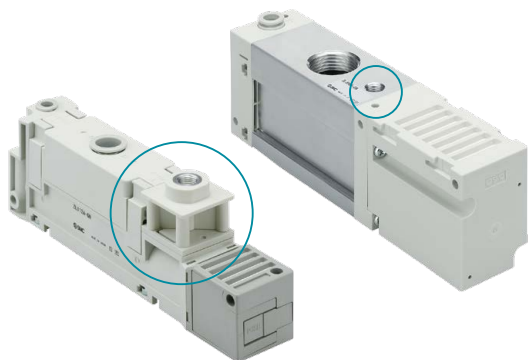

Without vacuum pressure sensor



Vacuum port: A branch specification is selectable.

ZL3

ZL6

- Easy connection of branch piping
- One-touch fittings can be connected without a bushing.

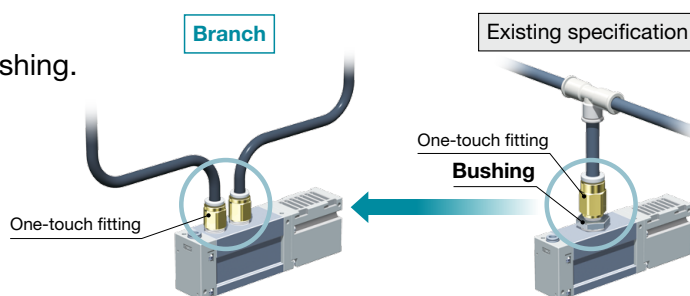
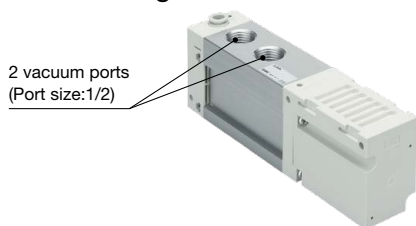

Standard supply pressure: A 0.35 MPa specification has been added.

ZL3

ZL6

- Supports the adoption of low supply pressure

IO-Link Compatible Vacuum Pressure Switch/M12 Connector p. 23, 24 **ZL3** **ZL6**

Visualization of operation/equipment status/Remote monitoring and control by communication

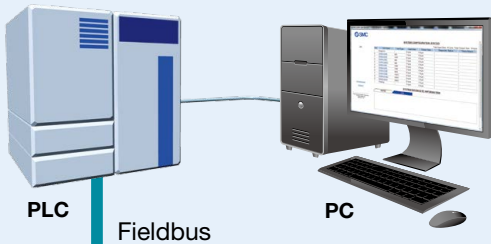

Configuration File (IODD File*1)

·Manufacturer ·Product part no. ·Set value

*1 IODD File:
IODD is an abbreviation of IO Device Description. This file is necessary for setting the device and connecting it to a master. Save the IODD file on the PC to be used to set the device prior to use.

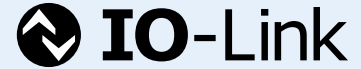

IO-Link is an open communication interface technology between the sensor/actuator and the I/O terminal that is an international standard: IEC 61131-9.

Device settings can be set by the master.

- Threshold value
- Operation mode, etc.

Read the device data.

- ON/OFF signal and analog value
- Device information: Manufacturer, Product part number, Serial number, etc.
- Normal or abnormal device status
- Cable breakage



IO-Link Compatible Device **ZL3, ZL6**

IO-Link Master

Implement diagnostic bits in the process data.

The diagnostic bit in the cyclic process data makes it easy to find problems with the equipment. It is possible to find problems with the equipment in real time using the cyclic (periodic) data and to monitor such problems in detail with the noncyclic (aperiodic) data.

Process Data

Input process data	Output process data
4 bytes	2 bytes

Error	Warning	Pressure value diagnosis
<ul style="list-style-type: none"> • OUT1/2 over current • Outside of zero-clear range • Temperature sensor failure • Master version mismatch 	<ul style="list-style-type: none"> • Valve protection warning • Energy saving operation warning 	<ul style="list-style-type: none"> • Above the upper limit/below the lower limit of the display range

Input Process Data

Byte	1								0								
Bit offset	15	14	13	12	11	10	9	8	7	6	5	4	3	2	1	0	
Item	System error	Error	Valve warning	PD_IN forced output	Reservation				Pressure value diagnosis	Release valve output	Supply valve output	Reservation	Pressure confirmation	Pressure confirmation	Release confirmation	Energy saving confirmation	Suction confirmation
Byte	3								2								
Bit offset	31	30	29	28	27	26	25	24	23	22	21	20	19	18	17	16	
Item	Measured pressure value																

Output Process Data

Byte	1								0							
Bit offset	15	14	13	12	11	10	9	8	7	6	5	4	3	2	1	0
Item	Reservation								Reservation							
					Automatic release forced OFF				Valve protection forced OFF				Energy saving control forced OFF			
					Release instruction				Vacuum instruction							

Display function Displays the output communication status and indicates the presence of communication data

Operation and Display

Communication with master	Status	Screen display	Description		
Yes	Normal	Operate	oPE → 00 *1	Normal communication status (readout of measured value, command) * Output process data valid	
			idle ↔ 00 *1	Normal communication status (readout of measured value) * Output process data invalid	
		IO-Link mode	Start up	Str ↔ 00 *1	At the start of communication
			Preoperate	P-rE ↔ 00 *1	
No	Abnormal	Version does not match	E15	The IO-Link version does not match that of the master.*2	
		Communication disconnection	idle ↔ 00 *1	Normal communication was not received for 1 s or longer.	
			Str ↔ 00 *1		
	P-rE ↔ 00 *1				
	SIO mode*3		5.0 ↔ 00 *1	General switch output	

*1 Displays the measured value *2 When the product is connected to the master with version "V1.0," error E15 is generated. *3 Cannot be used in SIO mode

Energy saving is possible due to the vacuum pressure switch with energy saving function and efficient ejectors.

Air consumption **91% reduction**

*1 Based on SMC's measurement conditions

Energy saving function ON

Air is supplied **intermittently** when the vacuum decreases.

Energy saving function OFF

Air is supplied **continuously** during the adsorption of the workpiece.

Energy-saving pressure confirmation signal

When adsorbing a workpiece with a large amount of leakage, this signal allows for the confirmation of whether the energy-saving operation is being performed once the vacuum pressure that initiates the energy-saving control has been reached. This contributes to a reduction in air consumption.

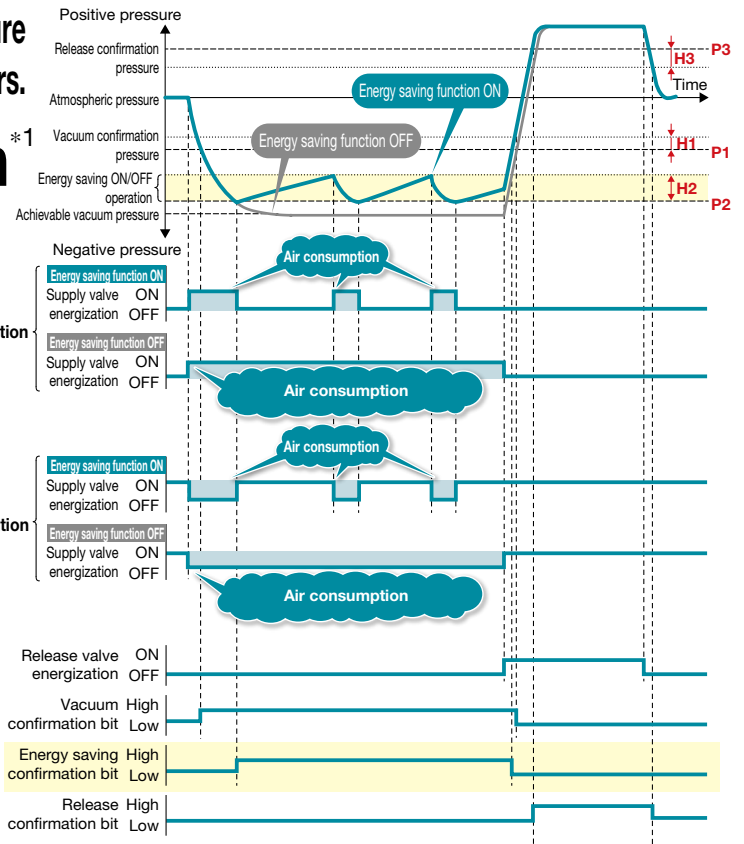

Automatic Release Function

When the supply valve operation instruction is turned OFF, the release valve ON operation is started automatically, reducing the amount of time required for the customer to construct an operating program.

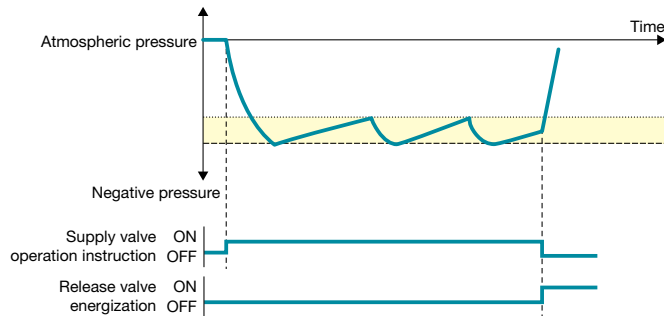

Valve Protection Function

If the supply valve reaches the set number of operations while the energy-saving function is in use, the energy-saving function automatically turns OFF and switches to continuous adsorption to prevent excessive valve operation.

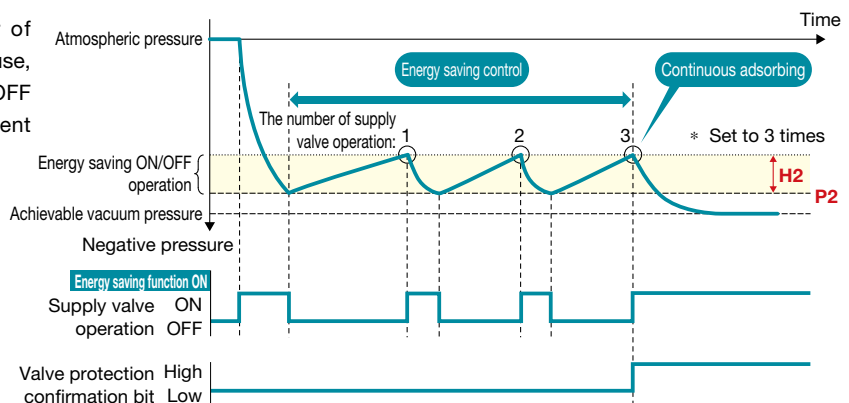

No tools are required. Reduced maintenance labor

ZL1

Filter element

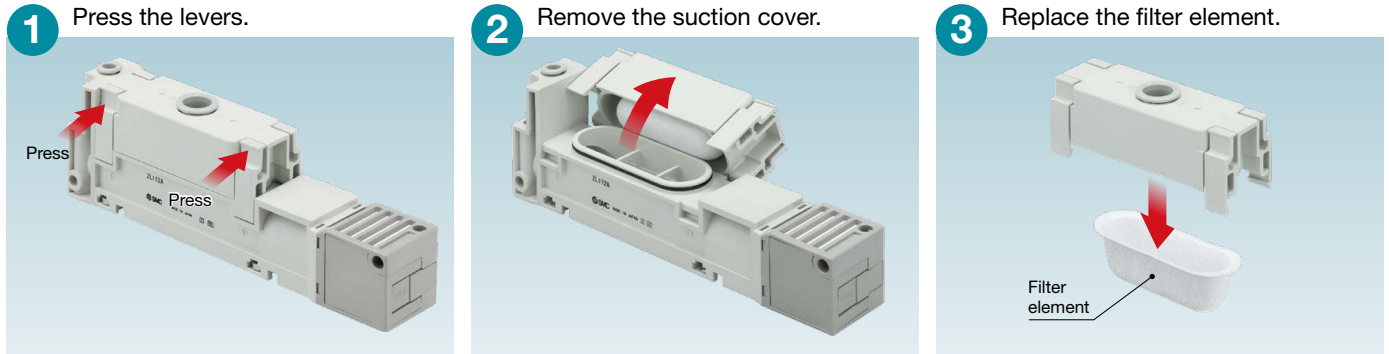

Sound absorbing material

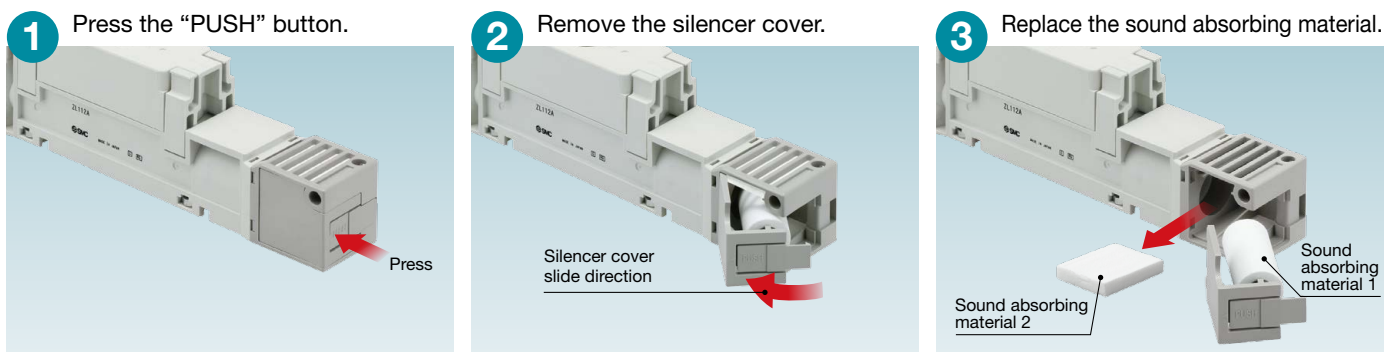

Supply valve/Release valve

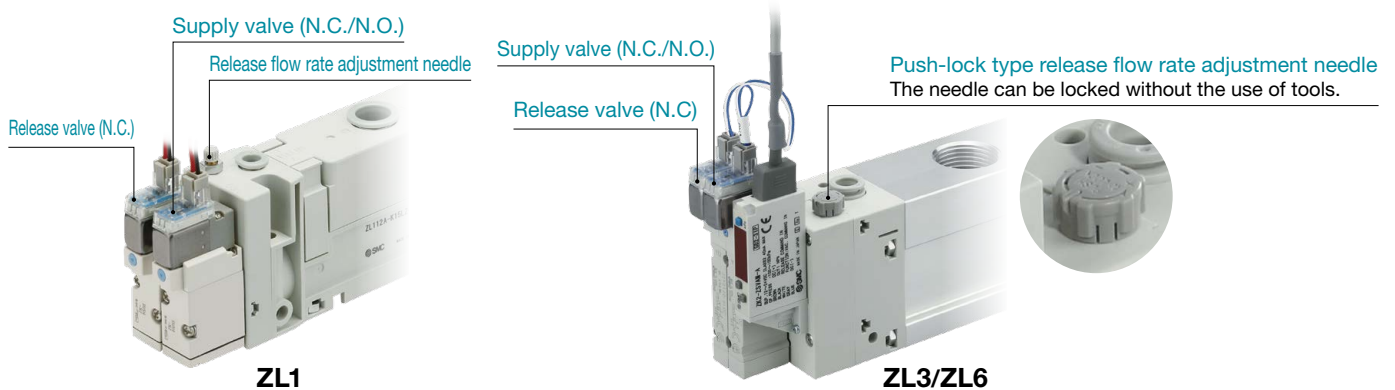

2 types of exhaust methods

■ Silencer exhaust (Noise level)*1



■ Port exhaust



*1 Actual values under SMC's measurement conditions

Variations

Series		ZL1	ZL3M	ZL3H	ZL6M	ZL6H
Nominal nozzle size [mm]		1.2	1.9	1.5	1.9 x 2	1.5 x 2
Standard supply pressure*1 [MPa]		0.33	0.35	0.50	0.35	0.50
Vacuum pressure [kPa]		-84	-91	-93	-91	-93
Max. suction flow rate [L/min (ANR)]		100	300*2		600*2	
Air consumption [L/min (ANR)]		57	150	135	300	270
Port size	Supply port	ø6 ø1/4"	ø8 ø5/16"			
	Vacuum port	ø12 ø1/2"	3/4 (Rc, NPT, G) 2 x 1/2 (Rc, NPT, G) (Branch specification)			
With or without valve	With supply valve and release valve	●	●	●	●	●
	Supply valve	●	●	●	●	●
	None	●	●	●	●	●
Exhaust type	Silencer exhaust	●	●	●	●	●
	Port exhaust	●	●	●	●	●
Pressure switch for vacuum with energy saving function	N.C. specification	●	●	●	●	●
	N.O. specification	●	●	●	●	●
IO-Link compatible vacuum pressure switch (The energy-saving function can be turned ON or OFF via the parameter settings.)	N.C. specification	●	●	●	●	●
	N.O. specification	●	●	●	●	●
Vacuum pressure sensor	With vacuum pressure switch	●	●	●	●	●
	With pressure gauge	●	●	●	●	●
	With detection port (Port size 1/8)	●	●	●	●	●
	None	●	●	●	●	●
M12 connector	IP65	●	●	●	●	●

*1 Without valve *2 Branch specification + Port exhaust

Mounting option

ZL1

ZL3

An adapter assembly is required for bottom mounting interchangeability with the previous model.

* The mounting holes on the top and on the side are interchangeable as standard.

Example) For the ZL3

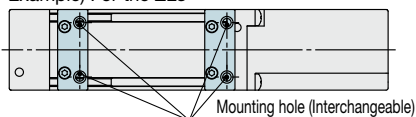

Bottom mounting for the ZL1 ↔ ZL112 (Previous model)

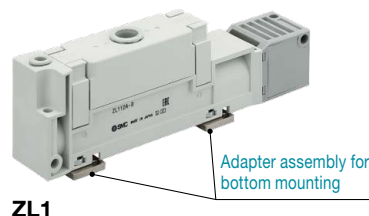

ZL1

Bottom mounting for the ZL3 ↔ ZL212 (Previous model)

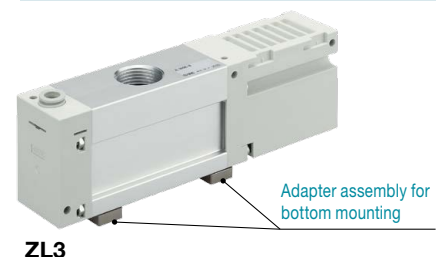

ZL3

CONTENTS

Multistage Ejector *ZL1/ZL3/ZL6 Series*

Multistage Ejector *ZL1 Series*



How to Order	
IP40	p. 9
Ejector Specifications	p. 10
Supply Valve/Release Valve Specifications	p. 10
Pressure Gauge Specifications	p. 10
Vacuum Pressure Switch Specifications	p. 11
Weight	p. 11
Vacuum Pressure Switch/Internal Circuits and Wiring Examples	p. 12
Exhaust Characteristics/Flow Rate Characteristics/Time to Reach Vacuum	p. 13
Vacuum Break Flow Rate Characteristics	p. 13
Construction	p. 14
How to Order Replacement Parts	p. 15
Dimensions	p. 17

Multistage Ejector *ZL3/ZL6 Series*

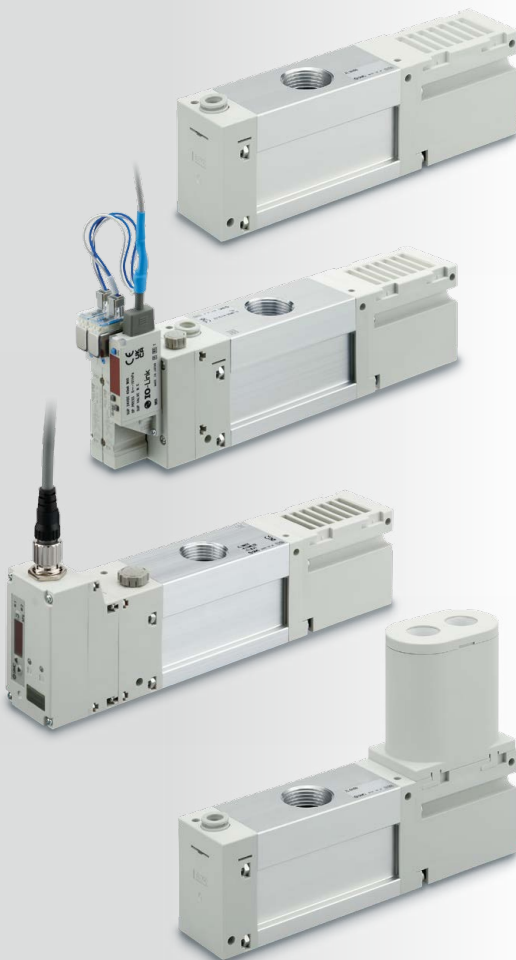

How to Order	
IP40	p. 21
M12 Connector IP65	p. 22
IO-Link Compatible IP40	p. 23
IO-Link Compatible M12 Connector IP65	p. 24
Ejector Specifications	p. 25
Supply Valve/Release Valve Specifications	p. 25
Pressure Gauge Specifications	p. 26
Weight	p. 26
Vacuum Pressure Switch Specifications	p. 27
IO-Link Compatible Vacuum Pressure Switch Specifications	p. 27
Internal Circuits and Wiring Examples	p. 28
IO-Link: Process Data	p. 28
Exhaust Characteristics	p. 30
Flow Rate Characteristics/Time to Reach Vacuum	p. 31
Break Flow Rate Characteristics/Vacuum Breaking Time	p. 32
Construction	p. 33
How to Order Replacement Parts	p. 34
Dimensions	p. 38
Accessories	p. 44
Safety Instructions	Back cover

ZL1 Series

ZL3/ZL6 Series

Multistage Ejector

Max. suction flow rate:
100 L/min (ANR)

ZL1 Series



Only for the models with a valve or pressure switch
AC voltage valves are not compliant.

RoHS

IP40

How to Order

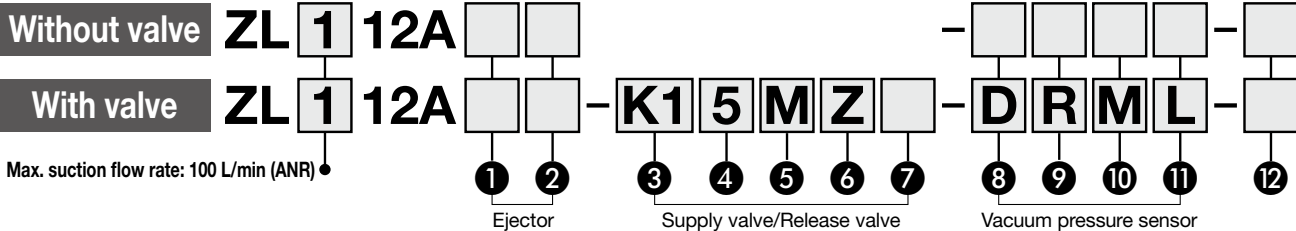

1 Supply (P), Vacuum (V) port/ One-touch fitting connection size

Symbol	Supply (P) port	Vacuum (V) port	Pressure gauge unit*1
Nil	ø6 (Metric)	ø12 (Metric)	kPa
N	ø1/4" (Inch)	ø1/2" (Inch)	inHg·psi

*1 When the vacuum pressure gauge (Symbol: G) is selected for 8, these are the unit specification options.
Under the New Measurement Act, products with inHg·psi unit specifications are not permitted for use in Japan.

2 Exhaust method

Nil	Silencer exhaust
P	Rc1/2 port exhaust
PF	G1/2 port exhaust*2
PN	1/2-14NPT port exhaust

*2 The thread ridge shape is in compliance with G thread standard ISO 228-1, but the other shapes are not in compliance with ISO 16030 or ISO 1179.

3 Supply valve/Release valve combination

K1	Supply valve (N.C.), Release valve (N.C.)
K2	Supply valve (N.C.)
B1	Supply valve (N.O.), Release valve (N.C.)
B2	Supply valve (N.O.)

4 Rated voltage

DC		CE/UKCA-compliant
5	24 VDC	●
6	12 VDC	●
V	6 VDC	●
S	5 VDC	●
R	3 VDC	●

AC (50/60 Hz)		CE/UKCA-compliant
1	100 VAC	—
2	200 VAC	—
3	110 VAC [115 VAC]	—
4	220 VAC [230 VAC]	—

* CE/UKCA-compliant: For DC only

5 Electrical entry

24, 12, 6, 5, 3 VDC/100, 110, 200, 220 VAC			
Grommet	L plug connector	M plug connector	MN: Without lead wire
G: Lead wire length 300 mm	L: With lead wire (300 mm)	M: With lead wire (300 mm)	MN: Without lead wire
H: Lead wire length 600 mm	LN: Without lead wire	LO: Without connector	MO: Without connector

* LN and MN types: With 2 sockets per valve

* Refer to page 15 for the lead wire length of L and M plug connectors.

6 Light/Surge voltage suppressor

Nil	Without light/surge voltage suppressor
S	With surge voltage suppressor
Z	With light/surge voltage suppressor
U	With light/surge voltage suppressor (Non-polar type)

* For type "U," only DC voltage is available.

* There is no "S" option for AC voltage valves because the generation of surge voltage is prevented by a rectifier.

7 Manual override

Nil	Non-locking push type
D	Push-turn locking slotted type

8 Vacuum pressure sensor

Nil	None
GN	With vacuum pressure detection port (Rc1/8)
G	Pressure gauge*3
D	Vacuum pressure switch

*3 For 1, the units for metric spec. fittings are in kPa.
The units for inch spec. fittings are in inHg·psi. (Under the New Measurement Act, products with these unit specifications are not permitted for use in Japan.)

12 Option (Included)

Nil	None
B	Adapter assembly for bottom mounting (ZL112A-AD1-A)

* Bottom mounting screw pitch = 28 mm

(Interchangeable with the previous ZL112 model)

* 2 pcs./set, with 4 bolts

* The mounting holes on the top and on the side are interchangeable as standard.

Adapter assembly for bottom mounting

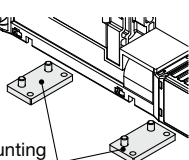

Applicable only when "D" is selected for 8 Vacuum pressure sensor

9 Output

X	NPN open collector 2 outputs + Copy function
Y	PNP open collector 2 outputs + Copy function
R	NPN open collector 2 outputs + Analog voltage output*4
S	NPN open collector 2 outputs + Analog current output*4
T	PNP open collector 2 outputs + Analog voltage output*4
V	PNP open collector 2 outputs + Analog current output*4

*4 Can be switched to auto-shift or copy function

10 Unit

Nil	With unit switching function*5
M	SI unit only (kPa)
P	With unit switching function (Initial value psi)*5

*5 Under the New Measurement Act, switches with the unit switching function are not permitted for use in Japan.

11 Connector/Lead wire

Nil	Without lead wire
L	Lead wire with connector (5 cores lead wire, 2 m)

If foreign matter is sucked in from the vacuum piping side, this may result in a malfunction.
Install an air suction filter (ZF□ series) or a vacuum filter (AFJ series) separately on the vacuum piping.

Without valve



With valve



With vacuum pressure switch



With pressure gauge



With vacuum pressure detection port



Port exhaust



Refer to pages 15 and 16 for How to Order Replacement Parts.

Ejector Specifications

Model		ZL1
Nozzle size [mm]		1.2
Standard supply pressure [MPa]	Without valve	0.33
	With valve	0.35
Max. vacuum pressure [kPa]*1		-84
Max. suction flow rate [L/min (ANR)]*1		100
Air consumption [L/min (ANR)]*1		57
Supply pressure range [MPa]		0.2 to 0.5
Operating temperature range [°C]		5 to 50 (No condensation)
Fluid		Air
Vibration resistance [m/s ²]*2	Without pressure switch	30
	With pressure switch	20
Impact resistance [m/s ²]*3	Without pressure switch	150
	With pressure switch	100

*1 Values are at the standard supply pressure and based on SMC's measurement standards. They depend on atmospheric pressure (weather, altitude, etc.) and the measurement method.
 *2 10 to 500 Hz for 2 hours in each direction of X, Y, and Z (De-energized, Initial value)
 *3 3 times in each direction of X, Y, and Z (De-energized, Initial value)

Supply Valve/Release Valve Specifications

Model	SYJ5□4
Response time (at 0.5 MPa)*1	25 ms or less
Max. operating frequency	5 Hz
Manual override	Non-locking push type, Push-turn locking slotted type

*1 Based on JIS B 8419: 2010 dynamic performance test (Standard type: Coil temperature 20°C, at rated voltage, without surge voltage suppressor)
 * Refer to the **Web Catalog** for details on the SYJ500 series.

Pressure Gauge Specifications

Model	ZL112A-PG1-A	ZL112A-PG2-A
Fluid	Air	
Pressure range	-100 to 100 kPa	-30 inHg to 14 psi
Scale range (Angular)	230°	
Accuracy	±3% F.S. (Full span)	
Operating temperature range	0 to 50°C	
Material	Housing: Polycarbonate/ABS resin	

Noise Level (Reference values)

Model	ZL1
Noise level [dB(A)]	65

Actual values under SMC's measurement conditions (Not guaranteed values)

Refer to pages 15 and 16 for How to Order Replacement Parts.

Vacuum Pressure Switch Specifications

Model		ZSE20A (Vacuum pressure)	
Applicable fluid		Air, Non-corrosive gas, Non-flammable gas	
Pressure	Rated pressure range	0.0 to -101.0 kPa	
	Display/Set pressure range	10.0 to -105.0 kPa	
	Display/Smallest settable increment	0.1 kPa	
	Withstand pressure	500 kPa	
Power supply	Power supply voltage	12 to 24 VDC $\pm 10\%$, Ripple (p-p) 10% or less	
	Current consumption	35 mA or less	
	Protection	Polarity protection	
Accuracy	Display accuracy	$\pm 2\%$ F.S. ± 1 digit (Ambient temperature of 25 $\pm 3^\circ\text{C}$)	
	Repeatability	$\pm 0.2\%$ F.S. ± 1 digit	
	Analog output accuracy	$\pm 2.5\%$ F.S. (Ambient temperature of 25 $\pm 3^\circ\text{C}$)	
	Analog output linearity	$\pm 1\%$ F.S.	
Temperature characteristics		$\pm 2\%$ F.S. (25 $^\circ\text{C}$ standard)	
Switch output	Output type	NPN or PNP open collector 2 outputs	
	Output mode	Hysteresis mode, Window comparator mode, Error output, Output OFF	
	Switch operation	Normal output, Reversed output	
	Max. load current	80 mA	
	Max. applied voltage (NPN only)	28 V	
	Internal voltage drop (Residual voltage)	1 V or less (at load current of 80 mA)	
	Delay time *1	1.5 ms or less (with anti-chattering function: 20, 100, 500, 1000, 2000, 5000 ms)	
	Hysteresis	Hysteresis mode	Variable from 0*2
		Window comparator mode	
	Short circuit protection		Yes
Analog output	Voltage output	Output type	Voltage output: 1 to 5 V
		Output impedance	Approx. 1 k Ω
		Output type	Current output: 4 to 20 mA
	Current output	Load impedance	Maximum load impedance at power supply voltage of 12 V: 300 Ω at power supply voltage of 24 V: 600 Ω Minimum load impedance: 50 Ω
Auto-shift input	Input type	Non-voltage input: 0.4 V or less	
	Input mode	Select from Auto-shift or Auto-shift zero.	
	Input time	5 ms or more	
Display	Unit *3	MPa, kPa, kgf/cm ² , bar, psi, inHg, mmHg	
	Display type	LCD	
	Number of screens	3-screen display (Main screen, Sub screen x 2)	
	Display color	1) Main screen: Red/Green 2) Sub screen: Orange	
	Number of display digits	1) Main screen: 4 digits (7 segments) 2) Sub screen: 4 digits (Upper 1 digit 11 segments, 7 segments for other)	
Indicator light		Lights up when switch output is turned ON. OUT1, OUT2: Orange	
Digital filter *4		0, 10, 50, 100, 500, 1000, 5000 ms	
Environmental resistance	Enclosure		IP40
	Withstand voltage		1000 VAC for 1 minute between terminals and housing
	Insulation resistance		50 M Ω or more (500 VDC measured via megohmmeter) between terminals and housing
	Operating temperature range		Operating: -5 to 50 $^\circ\text{C}$, Stored: -10 to 60 $^\circ\text{C}$ (No condensation or freezing)
Operating humidity range		Operating/Stored: 35 to 85% RH (No condensation)	
Standards		CE/UKCA marking	
Length of lead wire with connector		2 m	

*1 Value without digital filter (at 0 ms)

*2 If the applied pressure fluctuates around the set value, the hysteresis must be set to a value greater than the amount of fluctuation, or chattering will occur.

*3 Setting is only possible for models with the units selection function. Only MPa or kPa is available for models without this function.

*4 The response time indicates when the set value is 90% in relation to the step input.

For details on the ZSE20A, refer to the **Web Catalog** and the operation manual.

Weight

Model	ZL1
Basic type	180
Port exhaust	+70
Vacuum pressure switch (Excluding lead wire)	+26
Vacuum pressure switch (Including lead wire)	+68
With supply valve and release valve	+105
With supply valve and without release valve	+65

Vacuum Pressure Switch/Internal Circuits and Wiring Examples

-X
NPN (2 outputs) + Copy function

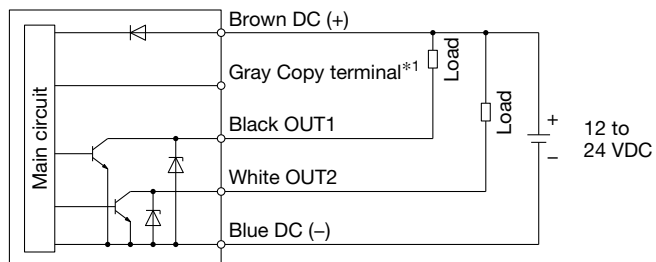

-Y
PNP (2 outputs) + Copy function

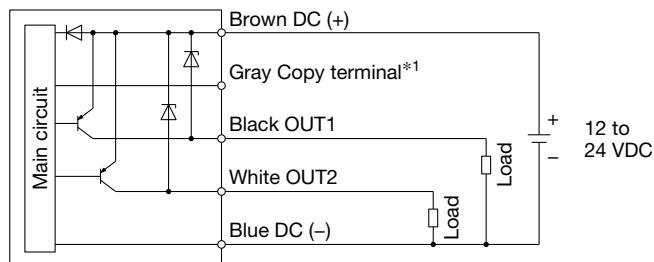

-R: NPN (2 outputs) + Analog voltage output
-S: NPN (2 outputs) + Analog current output

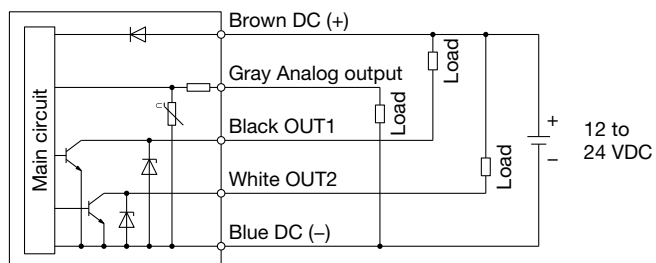

-T: PNP (2 outputs) + Analog voltage output
-V: PNP (2 outputs) + Analog current output

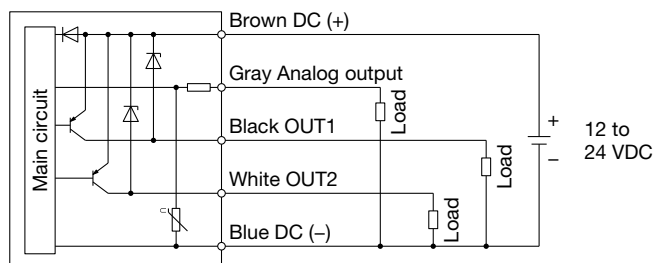

-R: NPN (2 outputs) + Auto-shift input
-S: NPN (2 outputs) + Auto-shift input

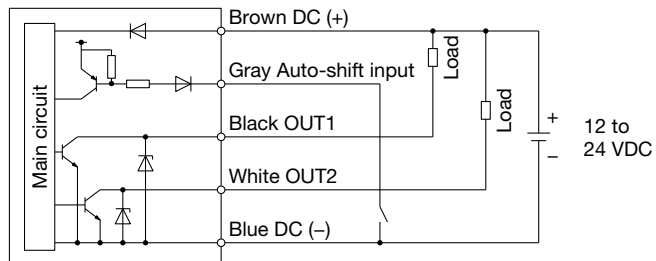

-T: PNP (2 outputs) + Auto-shift input
-V: PNP (2 outputs) + Auto-shift input

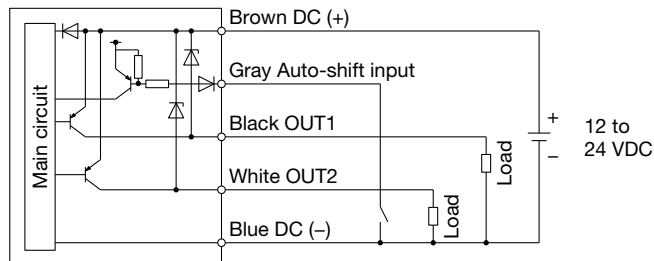

-R: NPN (2 outputs) + Copy function
-S: NPN (2 outputs) + Copy function

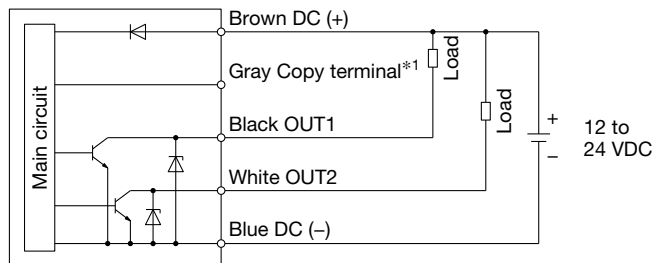

-T: PNP (2 outputs) + Copy function
-V: PNP (2 outputs) + Copy function

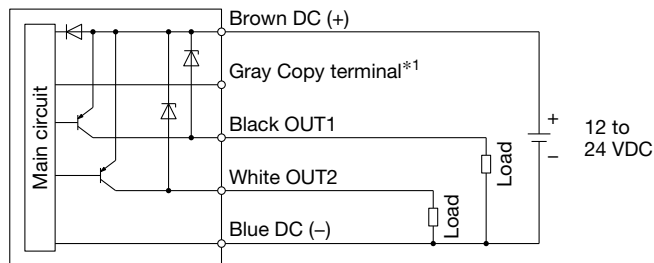

* Refer to the **Web Catalog** (ZSE20A series) for details on pressure switches.

ZL1 Series

ZL3/ZL6 Series

Exhaust Characteristics/Flow Rate Characteristics/Time to Reach Vacuum (Representative value)

Exhaust Characteristics (Without valve)

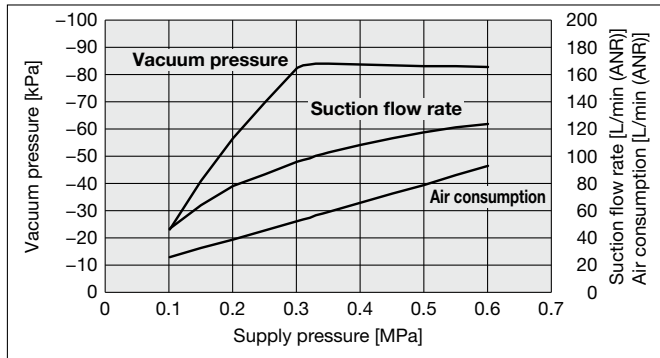

Exhaust Characteristics (With valve)

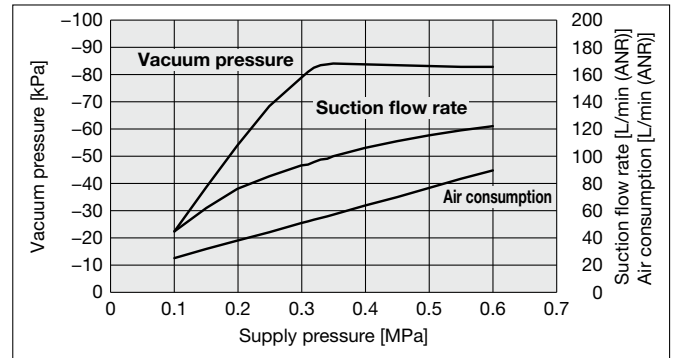

Flow Rate Characteristics

Standard supply pressure: 0.33 MPa (Without valve)
0.35 MPa (With valve)

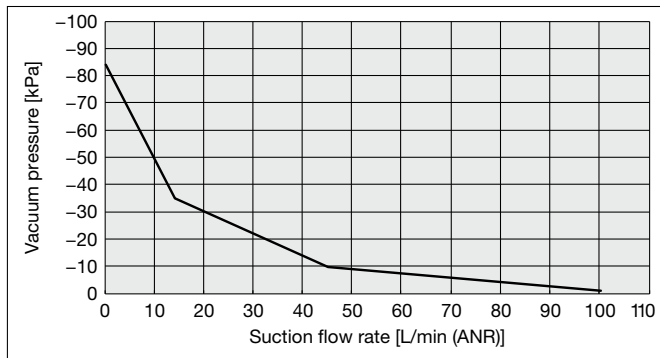

Time to Reach Vacuum

Tank capacity: 1 L

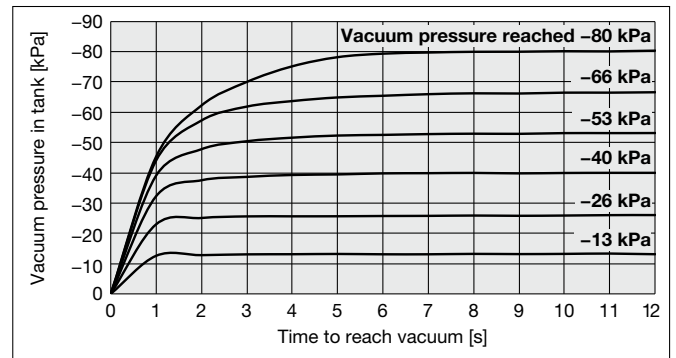

Vacuum Break Flow Rate Characteristics*1 (Representative value)

*1 Silencer exhaust specification

The graph shows the flow rate characteristics at different supply pressures when the release flow rate adjustment needle is open from the fully closed state.

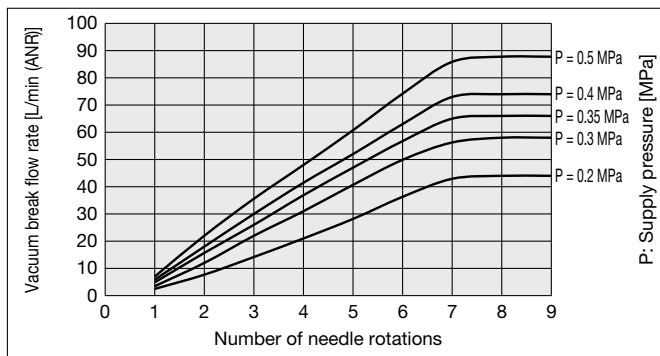

* The flow rates shown in this graph are representative values for the ejector with silencer exhaust specification, and the suction flow may vary depending on the piping conditions at the vacuum (V) port and exhaust (EXH) port, etc.

How to Read the Flow Rate Characteristics

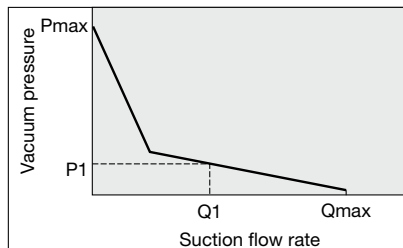

The flow rate characteristics indicate the relationship between the vacuum pressure and the suction flow rate of the ejector. They also show that when the suction flow rate changes, the vacuum pressure also changes. In general, this indicates the relationship at the ejector's standard operating pressure.

In the graph, Pmax indicates the max. vacuum pressure, and Qmax indicates the max. suction flow rate. These are the values that are published as specifications in catalogs, etc. Changes in vacuum pressure are explained below.

1. If the ejector's suction port is closed and sealed tight, the suction flow rate becomes "0," and the vacuum pressure increases to the max. (Pmax).
2. If the suction port is opened and air is allowed to flow (the air leaks), the suction flow rate increases, and the vacuum pressure decreases. (The condition of P1 and Q1)
3. If the suction port is opened completely, the suction flow rate increases to the max. (Qmax), while the vacuum pressure then drops almost to "0" (atmospheric pressure). When adsorbing workpieces which are permeable, subject to leakage, etc., caution is required as the vacuum pressure will not be very high.

How to Read the Time to Reach Vacuum

The graph indicates the time required to reach a vacuum pressure determined by adsorption conditions for workpieces, etc., starting from atmospheric pressure in a 1 L sealed tank. For the ZL1, approximately 7.0 seconds are necessary to attain a vacuum pressure of -80 kPa.

Construction

Without valve or vacuum pressure switch, Silencer exhaust

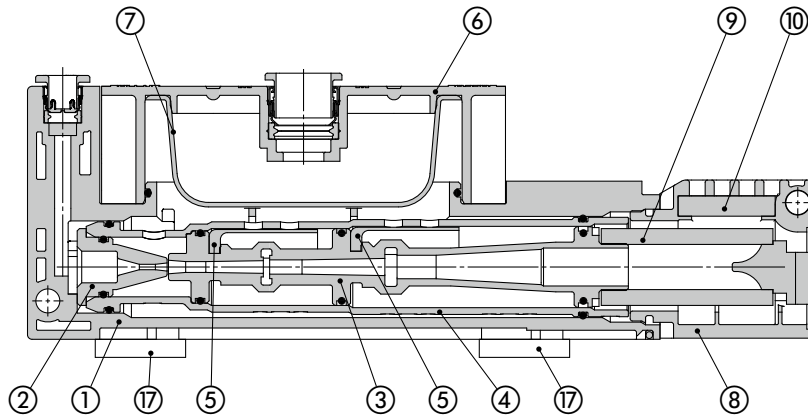

With valve and vacuum pressure switch, Port exhaust

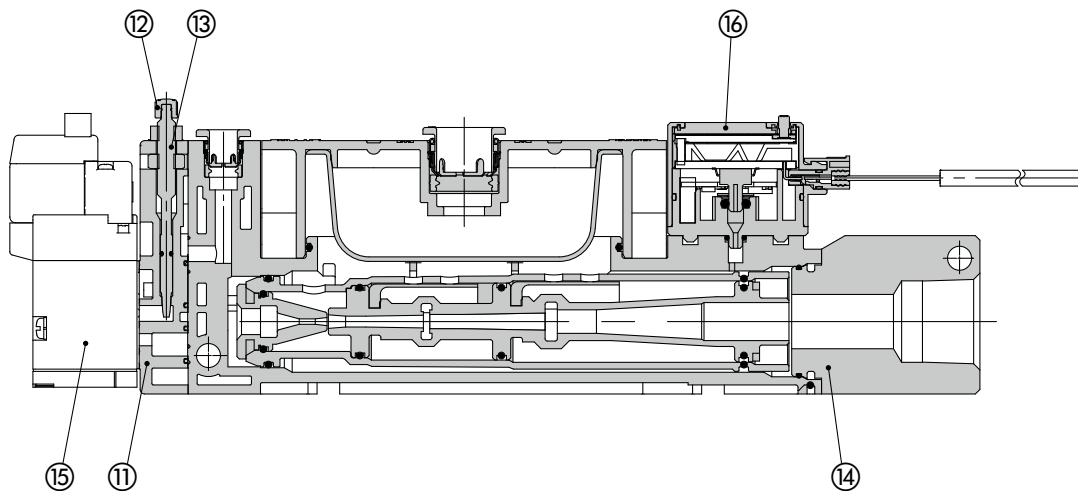

Component Parts

No.	Description	Material	Note
1	Body	PBT	—
2	Nozzle	POM	
3	Diffuser	PBT	Refer to 8 on page 16 for replacement parts.
4	Attachment	POM	
5	Check valve	FKM	
6	Suction cover	PBT	
7	Filter element	Non-woven fabric	Refer to 8 on page 16 for replacement parts.
8	Silencer case assembly	PBT/Stainless steel	Refer to 4 on page 16 for replacement parts.
9	Sound absorbing material 1	Resin	Refer to 9 on page 16 for replacement parts.
10	Sound absorbing material 2	Resin	
11	Valve plate	PBT	
12	Knob	POM	Refer to 7 on page 16 for replacement parts.
13	Needle	Brass (Electroless nickel plating)	
14	Port block assembly	Aluminum alloy/NBR/Stainless steel	Refer to 5 on page 16 for replacement parts.
15	Supply valve, Release valve	—	Refer to 1 on page 15 for replacement parts.
16	Vacuum pressure switch	—	Refer to 2 on page 15 for replacement parts.
17	Adapter assembly for bottom mounting	Brass (Electroless nickel plating)	Refer to 10 on page 16 for replacement parts.
—	Seal material (O-ring, etc.)	HNBR/NBR	—
—	Screws for assembly	Steel	—

ZL1 Series

How to Order Replacement Parts

1 How to Order Supply Valve/Release Valve

SYJ5 **1** 4 - **5** **M** **Z** **□** - **Q**

① ② ③ ④ ⑤ ⑥

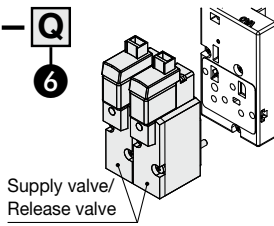

1 Type of actuation

1	Normally closed
2	Normally open (Supply valve only)

2 Rated voltage

DC	CE/UKCA-compliant	AC (50/60 Hz)	CE/UKCA-compliant
5	●	1	—
6	●	2	—
V	●	3	—
S	●	4	—
R	●		

* CE/UKCA-compliant: For DC only

3 Electrical entry

24, 12, 6, 5, 3 VDC/100, 110, 200, 220 VAC			
Grommet	L plug connector	M plug connector	
G : Lead wire length 300 mm	L : With lead wire (300 mm)	M : With lead wire (300 mm)	MN : Without lead wire
H : Lead wire length 600 mm	LN : Without lead wire	LO : Without connector	MO : Without connector

* LN and MN types: With 2 sockets

* For the lead wire length of the L and M plug connectors, refer to the lead wire with connector assembly for supply valves and release valves.

4 Light/Surge voltage suppressor

(Electrical entry: G, H, L, or M)

Nil	Without light/surge voltage suppressor
S	With surge voltage suppressor
Z	With light/surge voltage suppressor
U	With light/surge voltage suppressor (Non-polar type)

* There is no "S" option for AC voltage valves because the generation of surge voltage is prevented by a rectifier.

* For type "U," only DC voltage is available.

5 Manual override

Nil	Non-locking push type
D	Push-turn locking slotted type

6 CE/UKCA-compliant

Nil	— (For AC)
Q	CE/UKCA-compliant (For DC)

How to Order Connector and Socket for Supply Valve/Release Valve

SY100-30-A

* With connector and 2 sockets only

How to Order Lead Wire with Connector Assembly for Supply Valve/Release Valve

SY100-30-**4** A - **6**

① ②

1 Power supply voltage

1	100 VAC
2	200 VAC
3	Other VAC
4	DC

2 Lead wire length

Nil	300 mm
6	600 mm
10	1000 mm
15	1500 mm
20	2000 mm
25	2500 mm
30	3000 mm
50	5000 mm

2 How to Order Vacuum Pressure Switch

ZL-ZSE20A-**R**-**M**-00-**L**

① ② ③

1 Output

X	NPN open collector 2 outputs + Copy function
Y	PNP open collector 2 outputs + Copy function
R	NPN open collector 2 outputs + Analog voltage output
S	NPN open collector 2 outputs + Analog current output
T	PNP open collector 2 outputs + Analog voltage output
V	PNP open collector 2 outputs + Analog current output

2 Unit

Nil	With unit switching function*1
M	SI unit only
P	With unit switching function (Initial value psi)*1

*1 Under the New Measurement Act, switches with the unit switching function are not permitted for use in Japan.

3 Connector/Lead wire

Nil	Without lead wire
L	Lead wire with connector (Length: 2 m)

How to Order Lead Wire Assembly with Connector

ZS-46-5 L

* 2 m lead wire, 5 cores

3 How to Order Suction Cover Assembly

ZL112A-FC1 **□** - A

①

Suction cover assembly
(With filter element)

1 Vacuum port size

Nil	Applicable tubing O.D. $\phi 12$
N	Applicable tubing O.D. $\phi 1/2"$

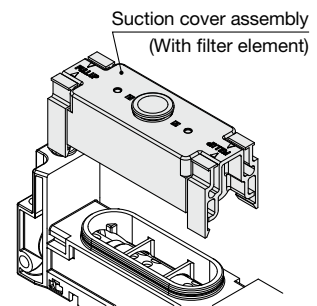

How to Order Replacement Parts

4 How to Order Silencer Case Assembly

ZL112A – SC1 – A

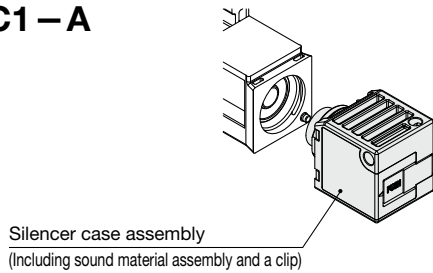

5 How to Order Port Block Assembly

ZL112A – EP1 – A

1

1 Thread type

Nil	Rc thread
F	G thread
N	NPT thread

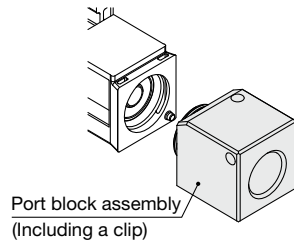

6 How to Order Ejector Assembly

ZL112A – EJ1 – A

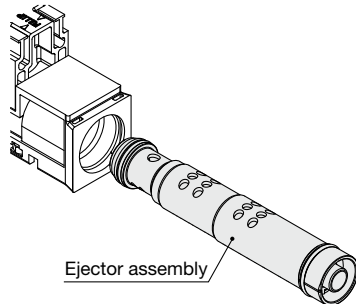

7 How to Order Valve Plate Assembly*1

ZL112A – VP 1 – A

1

1 Supply valve/Release valve combination

1	Supply valve + Release valve
2	Supply valve only

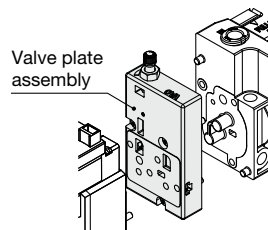

*1 It is not possible to switch between models with valves and models without valves.

8 How to Order Filter Element

ZL112A – FE1 – A

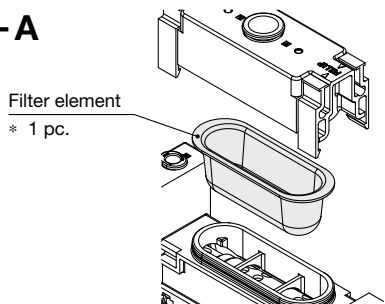

9 How to Order Sound Absorbing Material Assembly

ZL112A – SE1 – A

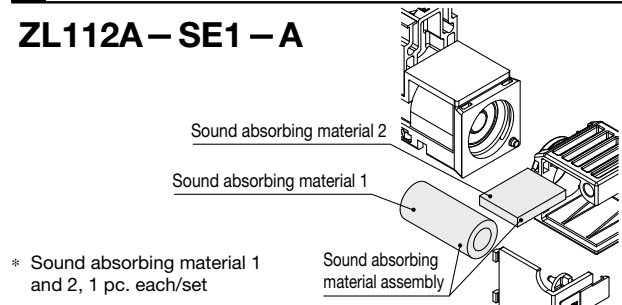

10 How to Order Adapter Assembly for Bottom Mounting

ZL112A – AD1 – A

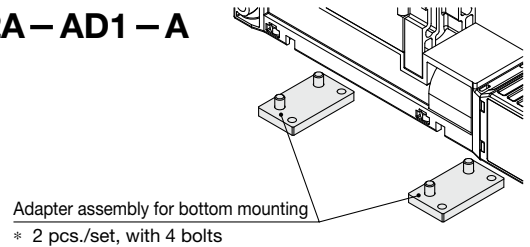

How to Order Vacuum Port Adapter Assembly*2

ZL112A – AD2 – A

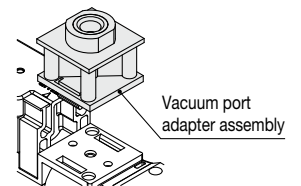

*2 A vacuum port adapter cannot be installed when "Nil" is selected for the pressure sensor.

How to Order Pressure Gauge Assembly*3

ZL112A – PG 1 – A

1

1 Units for pressure

1	kPa
2	inHg·psi*4

*4 Under the New Measurement Act, products with inHg·psi unit specifications are not permitted for use in Japan.

*3 A pressure gauge cannot be installed when "Nil" is selected for the pressure sensor.

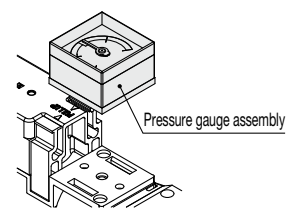

How to Order O-ring for Suction Cover

ZL112A – OR1 – A

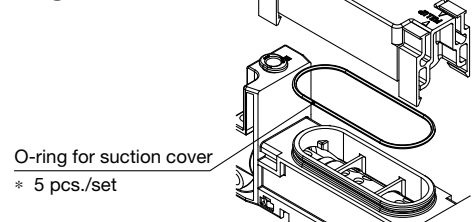

ZL1 Series

Dimensions

ZL112A(N) Without valve

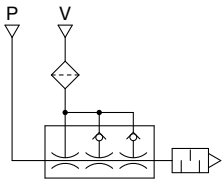

Circuit diagram

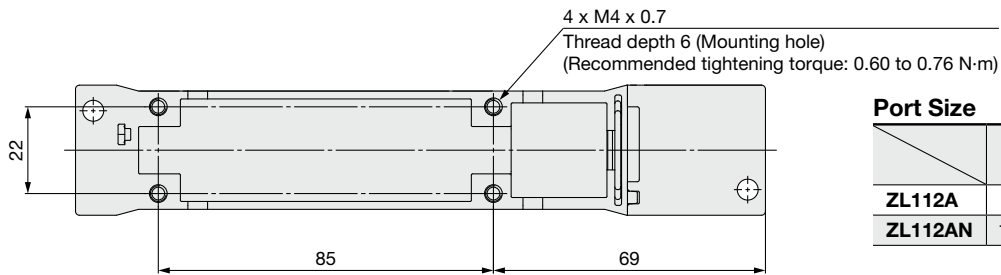
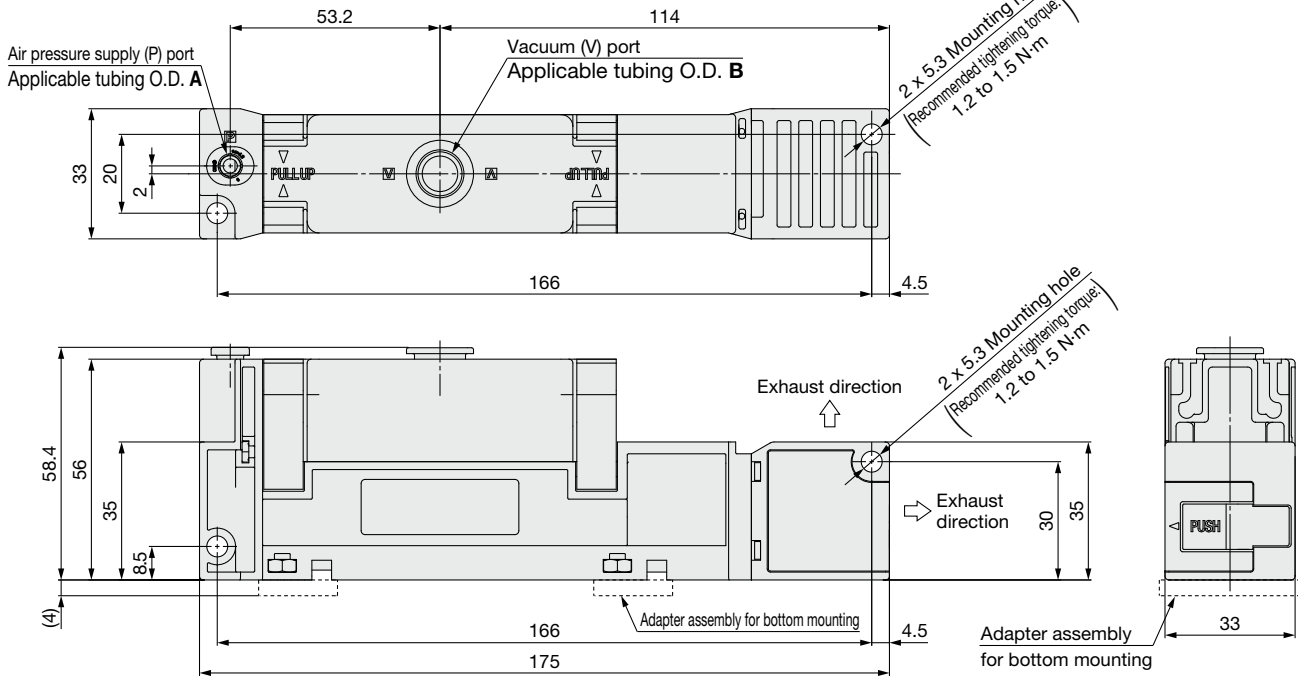

Port Size

	A	B
ZL112A	6	12
ZL112AN	1/4"	1/2"

Release Button

	P port		V port	
	Color	Type	Color	Type
ZL112A	Light gray	Oval	Light gray	Round
ZL112AN	Orange	Round	Orange	Round

Option

ZL112A(N)-B With adapter assembly for bottom mounting

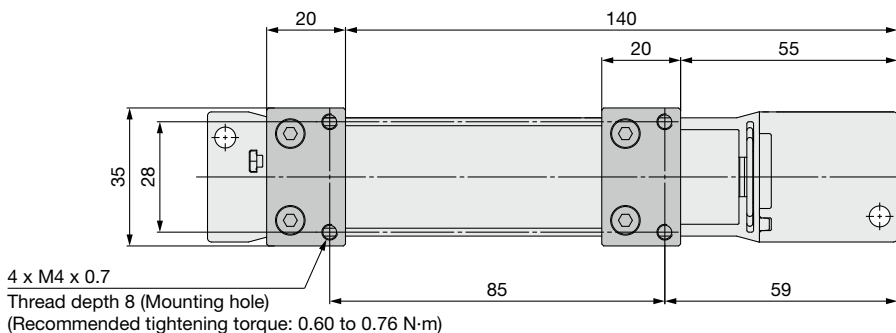

* Tighten to the recommended torque to mount the body. Tightening with excessive force may damage the product.

Dimensions

* Dimensions other than those shown below are the same as those of the type without a valve. Refer to the type without a valve on page 17 for details.

ZL112A-K1 □L□□ With valve (Supply valve and release valve)

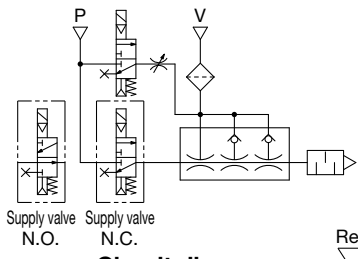

Circuit diagram

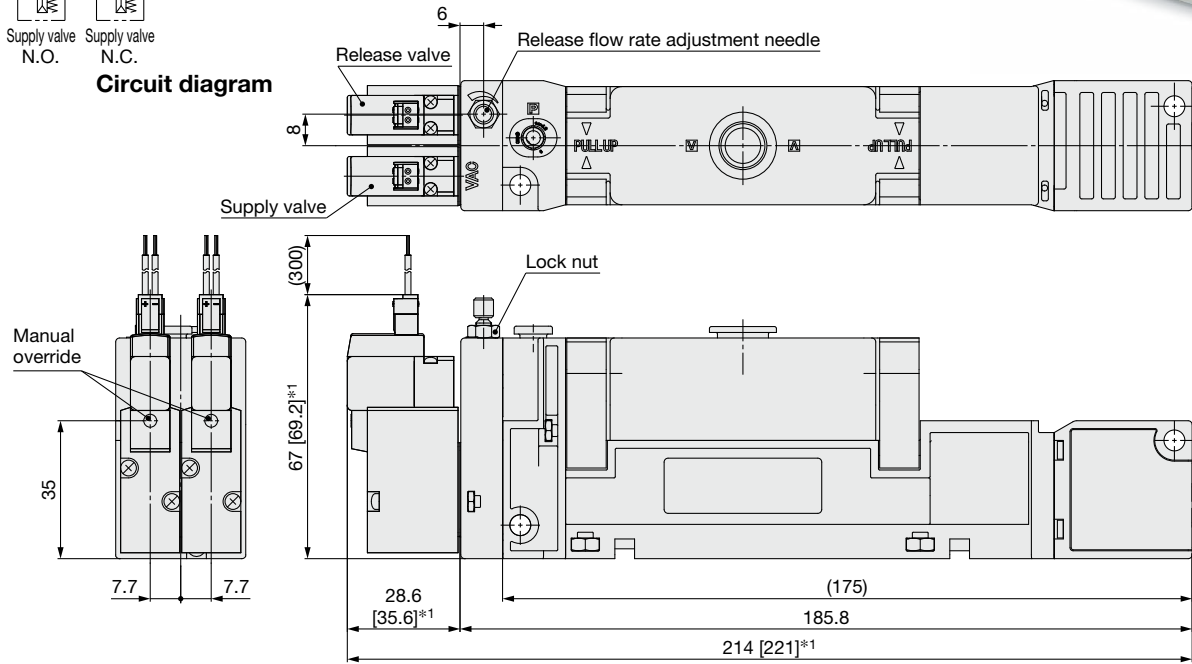
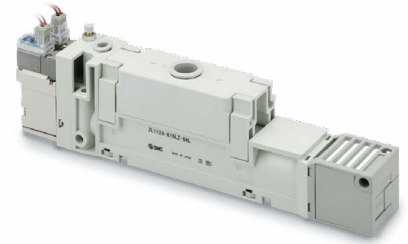

ZL112A-K2 B2 □L□□ With valve (Supply valve)

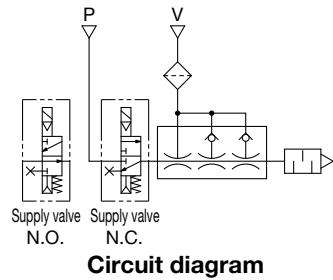

Circuit diagram

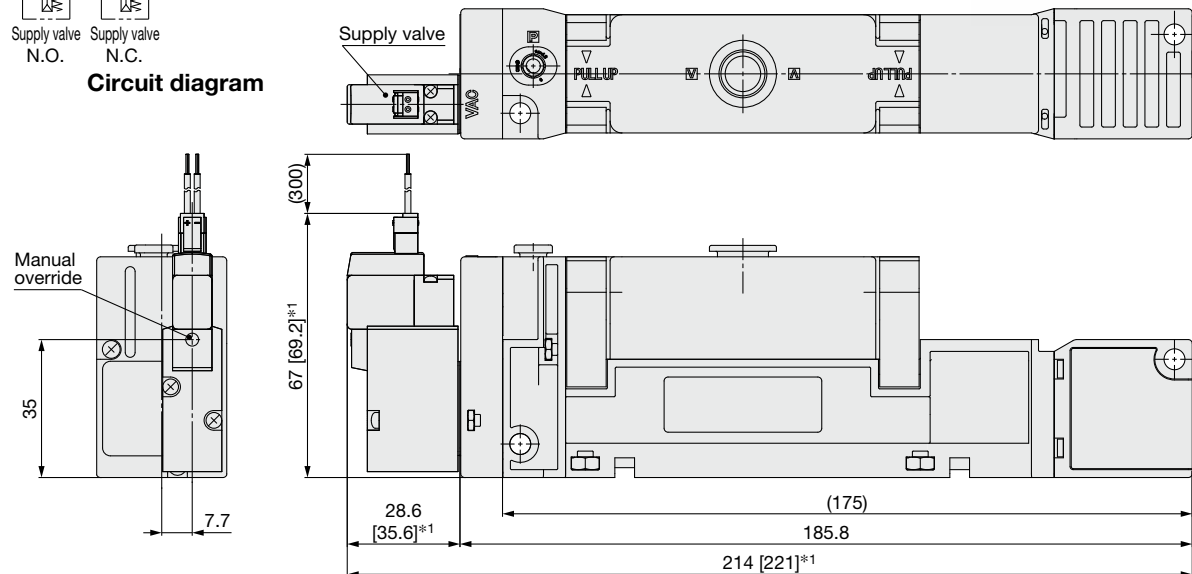
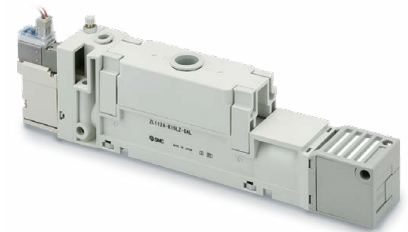

*1 [] for AC

* Tighten to the recommended torque on pages 17 and 19 to mount the body. Tightening with excessive force may damage the product.

ZL1 Series

Dimensions

ZL112AP□ Port exhaust

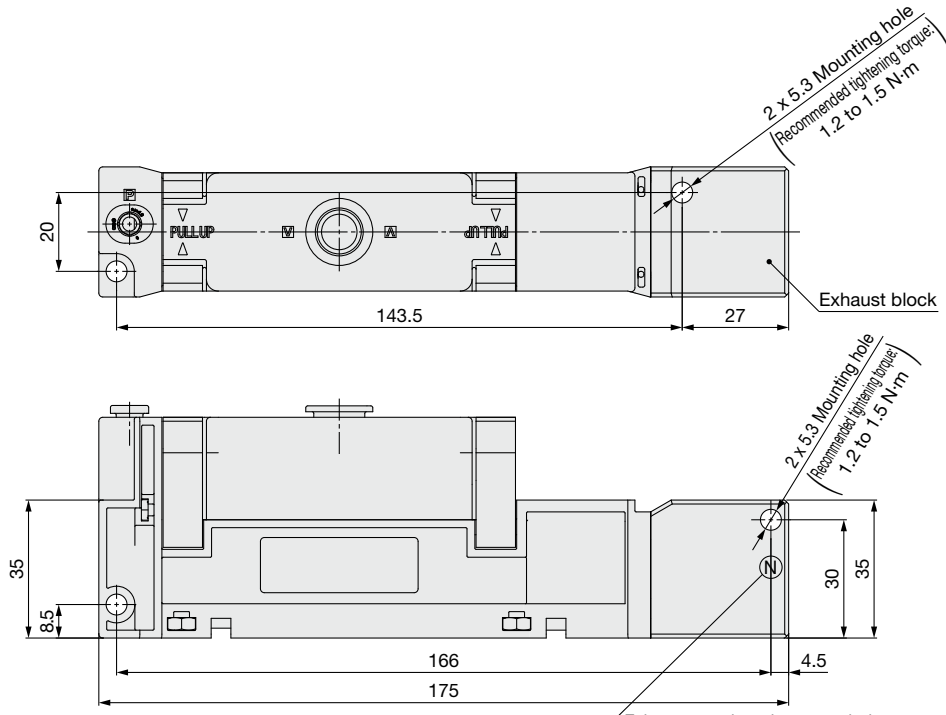

*1 The thread ridge shape is in compliance with G thread standard ISO 228-1, but the other shapes are not in compliance with ISO 16030 or ISO 1179. Use a male thread with a length of 9 or less for connection.

Exhaust port thread type symbol
 Nil: Rc thread
 F: G thread
 N: NPT thread

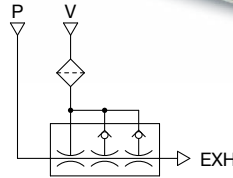

Circuit diagram

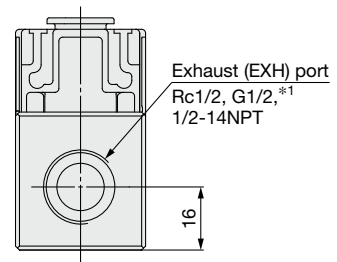

* Hold the exhaust block when connecting piping to the exhaust port. (Recommended tightening torque: 20 to 25 N·m)

ZL112A-D□□□ With vacuum pressure switch

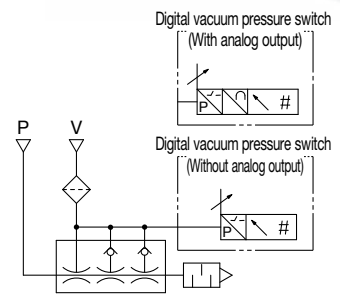
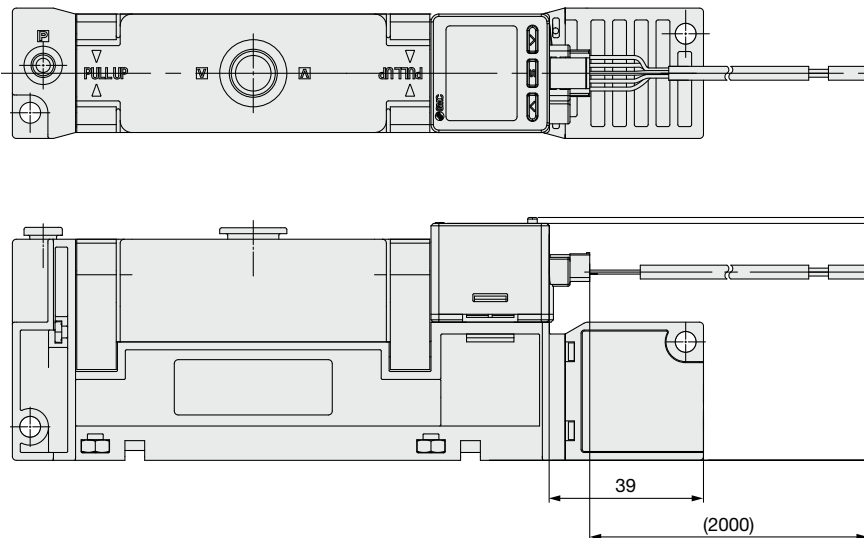

Circuit diagram

* Tighten to the recommended torque to mount the body. Tightening with excessive force may damage the product.

Dimensions

Options

ZL112A-GN With vacuum pressure detection port

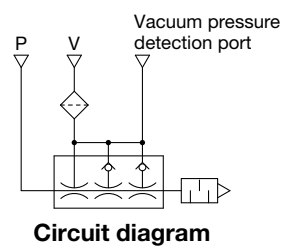
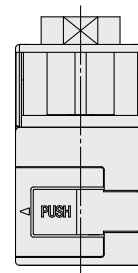
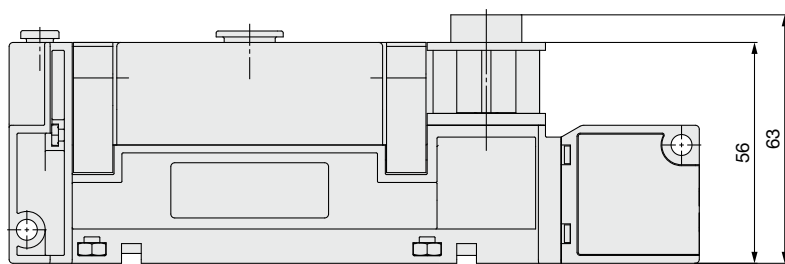
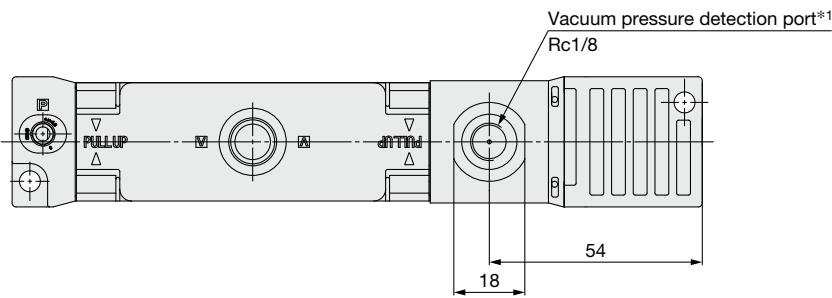

*1 Hold across the flats (18) when mounting a fitting to the vacuum pressure detection port. (Recommended tightening torque: 3 to 5 N·m)

ZL112A-G With pressure gauge

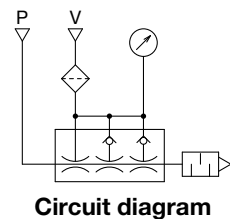
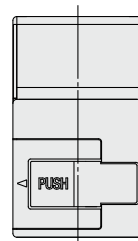
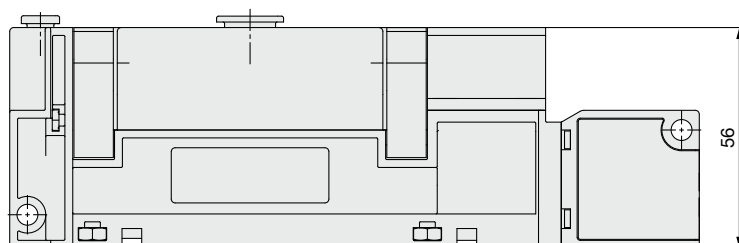
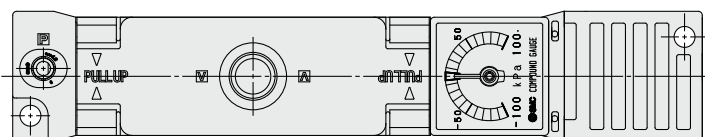

* Tighten to the recommended torque on pages 17 and 19 to mount the body. Tightening with excessive force may damage the product.

Multistage Ejector

Max. suction flow rate:
300 L/min (ANR)

Max. suction flow rate:
600 L/min (ANR)

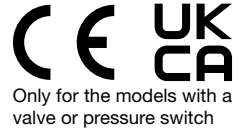

Only for the models with a valve or pressure switch

ZL3/ZL6 Series

RoHS

IP40

How to Order

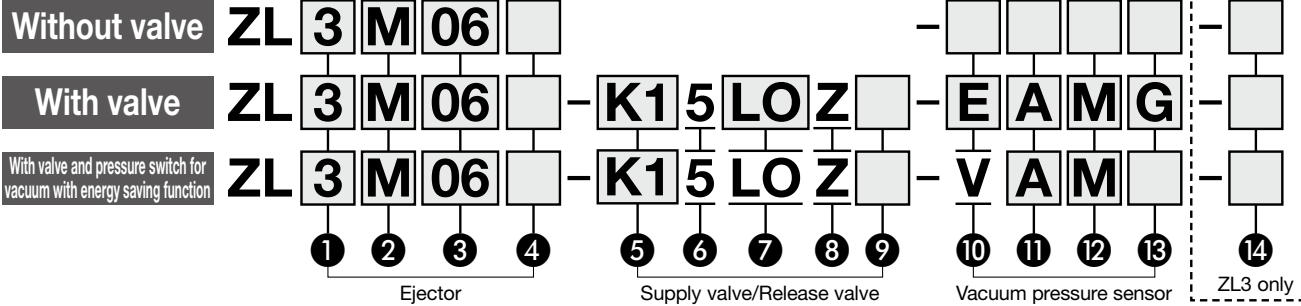

1 Max. suction flow rate

3	300 L/min (ANR)*1
6	600 L/min (ANR)*1

*1 Branch specification + Port exhaust

2 Standard supply pressure

M	0.35 MPa
H	0.50 MPa

3 Vacuum (2/V) port size/ Supply (1/P) port applicable tubing O.D.

Symbol	Vacuum (2/V) port	Supply (1/P) port
06	Rc3/4	8 (Metric)
04	2 x Rc1/2 (Branch specification)	
F06	G3/4*2	
F04	2 x G1/2*2 (Branch specification)	
N06	NPT3/4	5/16" (Inch)
N04	2 x NPT1/2 (Branch specification)	

*2 The thread ridge shape is in compliance with G thread standard ISO 228-1, but the other shapes are not in compliance with ISO 16030 or ISO 1179.

4 Exhaust method

Nil	Silencer exhaust
P	Port exhaust (Rc1, G1, NPT1)*3

*3 The same thread type selected for 3 is used for the port.

7 Electrical entry

L plug connector	M plug connector
L: Lead wire length 0.3 m 	M: Lead wire length 0.3 m
LO: Without connector*5 	MO: Without connector

*5 Only "LO" is selectable when the pressure switch with energy saving function is selected.

9 Manual override

Nil	Non-locking push type
D	Push-turn locking slotted type
E	Push-turn locking lever type

10 Vacuum pressure sensor

Symbol	Pressure detection method	Pressure range	Output
Nil	None	—	—
GN	Vacuum pressure detection port (Rc1/8, G1/8, NPT1/8)*6	—	—
G	Pressure gauge*7	-100 to 100 kPa/ -30 inHg to 14 psi	—
E	Vacuum pressure switch	0 to -101 kPa	2 outputs
F	Vacuum pressure switch	—	—
V	Pressure switch for vacuum with energy saving function*8	-100 to 100 kPa	1 output

*6 The same thread type selected for 3 is used for the port.

*7 Not selectable when "F06" or "F04" is selected for 3. When "06" or "04" is selected for 3, the units of the pressure gauge are displayed in kPa. When "N06" or "N04" is selected, the units are displayed in inHg-psi (Under the New Measurement Act, products with these unit specifications are not permitted for use in Japan.)

*8 When "V" is selected, "K1" or "B1" can be selected for 5, and only "LO" can be selected for 7.

5 Supply valve/Release valve combination

		Without pressure switch with energy saving function	With pressure switch with energy saving function
K1	Supply valve (N.C.), Release valve (N.C.)*4	●	●
K2	Supply valve (N.C.)	●	—
B1	Supply valve (N.O.), Release valve (N.C.)*4	●	●
B2	Supply valve (N.O.)	●	—

*4 Only "K1" or "B1" is selectable when the pressure switch with energy saving function is selected.

6 Rated voltage

5	24 VDC
---	--------

8 Light/Surge voltage suppressor

Z	With light/surge voltage suppressor
---	-------------------------------------

Applicable only when "E," "F," or "V" is selected for 10 Vacuum pressure sensor

11 Output

A	NPN open collector
B	PNP open collector

12 Unit

Nil	With unit switching function*9
M	SI unit only (kPa)
P	With unit switching function (Initial value psi)*9, *10

*9 Under the New Measurement Act, switches with the unit switching function are not permitted for use in Japan (implemented October 1999).

*10 When "V" is selected for 10, "P" cannot be selected.

13 Lead wire

Nil	Without lead wire with connector
G	Lead wire with connector (Length: 2 m) (Included)
W	Lead wire for switch with energy saving function (Length: 2 m) (Included)

Only applicable to ZL3

14 Option

Nil	None
B	Adapter assembly for bottom mounting*11 (Included)

*11 This adapter assembly is for adjusting the product to the 27 mm pitch of the bottom mounting thread of the previous ZL212 series model.

This is required when replacing a previous bottom-mounted ZL212 series model. (2 pcs./set, with 4 bolts)
The mounting holes on the side are interchangeable as standard.

Adapter assembly for bottom mounting

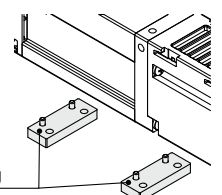

If foreign matter is sucked in from the vacuum piping side, this may result in a malfunction. Install an air suction filter (ZF□ series) or a vacuum filter (AFJ series) separately on the vacuum piping.

Multistage Ejector

Max. suction flow rate:
300 L/min (ANR)

Max. suction flow rate:
600 L/min (ANR)

M12 Connector



ZL3/ZL6 Series



IP65

How to Order

With valve and vacuum pressure switch

ZL **3** **M** **06** **□** - **K1** **5** **MO** **Z** **B** - **E** **A** **M** **J** **1**

With valve and pressure switch for vacuum with energy saving function

ZL **3** **M** **06** **□** - **K1** **5** **MO** **Z** **B** - **V** **A** **M** **J** **2**



1 Max. suction flow rate

3	300 L/min (ANR)*1
6	600 L/min (ANR)*1

*1 Branch specification + Port exhaust

2 Standard supply pressure

M	0.35 MPa
H	0.50 MPa

3 Vacuum (2/V) port size/ Supply (1/P) port applicable tubing O.D.

Symbol	Vacuum (2/V) port	Supply (1/P) port
06	Rc3/4	8 (Metric)
04	2 x Rc1/2 (Branch specification)	
F06	G3/4*2	
F04	2 x G1/2*2 (Branch specification)	5/16" (Inch)
N06	NPT3/4	
N04	2 x NPT1/2 (Branch specification)	

*2 The thread ridge shape is in compliance with G thread standard ISO 228-1, but the other shapes are not in compliance with ISO 16030 or ISO 1179.

4 Exhaust method

Nil	Silencer exhaust
P	Port exhaust (Rc1, G1, NPT1)*3

*3 The same thread type selected for 3 is used for the port.

5 Supply valve/Release valve combination

		Without pressure switch with energy saving function	With pressure switch with energy saving function
K1	Supply valve (N.C.), Release valve (N.C.)*4	●	●
K2	Supply valve (N.C.)	●	—
B1	Supply valve (N.O.), Release valve (N.C.)*4	●	●
B2	Supply valve (N.O.)	●	—

*4 Only "K1" or "B1" is selectable when the pressure switch with energy saving function is selected.

6 Rated voltage

5	24 VDC
----------	--------

7 Electrical entry

M	plug connector
MO	Without connector

8 Light/Surge voltage suppressor

Z	With light/surge voltage suppressor
----------	-------------------------------------

9 Manual override

B	Locking slotted type
----------	----------------------

10 Vacuum pressure sensor

Symbol	Pressure detection method	Pressure range	Output
E	Vacuum pressure switch	0 to -101 kPa	2 outputs
F	Vacuum pressure switch		
V	Pressure switch for vacuum with energy saving function*5	-100 to 100 kPa	1 output

*5 When "V" is selected, only "K1" or "B1" can be selected for 5.

11 Output

A	NPN open collector
B	PNP open collector

12 Unit

Nil	With unit switching function*6
M	SI unit only (kPa)
P	With unit switching function (Initial value psi)*6, *7

*6 Under the New Measurement Act, switches with the unit switching function are not permitted for use in Japan (implemented October 1999).

*7 When "V" is selected for 10, "P" cannot be selected.

13 Connector size/Enclosure

Symbol	Connector size	Enclosure
J	M12	IP65

14 Power supply cable*8

Symbol	Without power supply cable	
1	Power supply cable (Straight): 2 m (Included)	With connector on one side (Socket/Discrete wires)
2	Power supply cable (Angled): 2 m (Included)	

*8 For a different power cable length, select Nil, and order one of the power cables listed on pages 45 or 46 separately.

If foreign matter is sucked in from the vacuum piping side, this may result in a malfunction. Install an air suction filter (ZF□ series) or a vacuum filter (AFJ series) separately on the vacuum piping.

Multistage Ejector IO-Link Compatible

Max. suction flow rate:
300 L/min (ANR)

Max. suction flow rate:
600 L/min (ANR)

ZL3/ZL6 Series



RoHS

IP40

How to Order

With valve and IO-Link compatible vacuum pressure switch

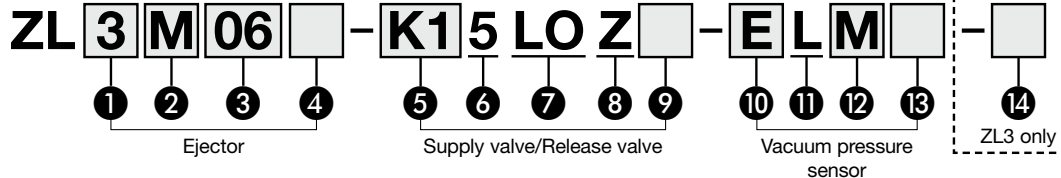

1 Max. suction flow rate

3	300 L/min (ANR)*1
6	600 L/min (ANR)*1

*1 Branch specification + Port exhaust

4 Exhaust method

Nil	Silencer exhaust
P	Port exhaust (Rc1, G1, NPT1)*3

*3 The same thread type selected for 3 is used for the port.

6 Rated voltage

5	24 VDC
---	--------

2 Standard supply pressure

M	0.35 MPa
H	0.50 MPa

5 Supply valve/Release valve combination

K1	Supply valve (N.C.), Release valve (N.C.)
B1	Supply valve (N.O.), Release valve (N.C.)

3 Vacuum (2/V) port size/ Supply (1/P) port applicable tubing O.D.

Symbol	Vacuum (2/V) port	Supply (1/P) port
06	Rc3/4	8 (Metric)
04	2 x Rc1/2 (Branch specification)	
F06	G3/4*2	
F04	2 x G1/2*2 (Branch specification)	5/16" (Inch)
N06	NPT3/4	
N04	2 x NPT1/2 (Branch specification)	

*2 The thread ridge shape is in compliance with G thread standard ISO 228-1, but the other shapes are not in compliance with ISO 16030 or ISO 1179.

8 Light/Surge voltage suppressor

Z	With light/surge voltage suppressor
---	-------------------------------------

9 Manual override

Nil	Non-locking push type
D	Push-turn locking slotted type
E	Push-turn locking lever type

7 Electrical entry

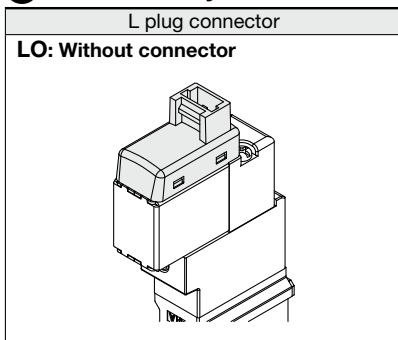

10 Vacuum pressure sensor

Symbol	Pressure detection method	Pressure range
E	IO-Link compatible	0 to -101 kPa
F	vacuum pressure switch	
V	IO-Link compatible vacuum pressure switch with energy saving function	-100 to 100 kPa

11 Output

L	IO-Link
---	---------

12 Unit

Nil	With unit switching function*4
M	SI unit only (kPa)

*4 Under the New Measurement Act, switches with the unit switching function are not permitted for use in Japan (implemented October 1999).

Only applicable to ZL3

14 Option

Nil	None
B	Adapter assembly for bottom mounting*5 (Included)

*5 This adapter assembly is for adjusting the product to the 27 mm pitch of the bottom mounting thread of the previous ZL212 series model. This is required when replacing a previous bottom-mounted ZL212 series model. (2 pcs./set, with 4 bolts)
The mounting holes on the side are interchangeable as standard.

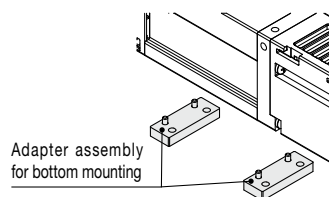

13 Lead wire

Nil	Without lead wire with connector
H	Lead wire with connector for IO-Link (With M12 connector): 300 mm (Included)

If foreign matter is sucked in from the vacuum piping side, this may result in a malfunction. Install an air suction filter (ZF□ series) or a vacuum filter (AFJ series) separately on the vacuum piping.

ZL3/ZL6 Series

Without valve



ZL3



ZL6

Branch



With valve



M12 connector/
IP65 specification



With pressure switch



Pressure switch for vacuum
with energy saving
function



With pressure gauge



With vacuum pressure
detection port



Port exhaust



Refer to pages 34 to 37 for How to Order Replacement Parts.

Ejector Specifications

ZL3

Model	ZL3M□□	ZL3H□□
Nozzle size [mm]	1.9	1.5
Standard supply pressure [MPa]	0.35	0.50
Max. vacuum pressure [kPa]*1	-91	-93
Max. suction flow rate [L/min (ANR)]	280	
Branch/Port exhaust	300	
Air consumption [L/min (ANR)]	150	135
Supply pressure range [MPa]	0.2 to 0.6	
Operating temperature range [°C]	-5 to 50 (No freezing or condensation)	
Fluid	Air	
Vibration resistance [m/s ²]*2	20	
Impact resistance [m/s ²]*3	100	

- *1 Values are at the standard supply pressure and based on SMC's measurement standards. They depend on atmospheric pressure (weather, altitude, etc.) and the measurement method.
 *2 10 to 500 Hz for 2 hours in each direction of X, Y, and Z (De-energized, Initial value)
 *3 3 times in each direction of X, Y, and Z (De-energized, Initial value)

ZL6

Model	ZL6M□□	ZL6H□□
Nozzle size [mm]	1.9 x 2	1.5 x 2
Standard supply pressure [MPa]	Without valve 0.35 With valve 0.37	0.50 0.52
Max. vacuum pressure [kPa]*1	-91	
Max. suction flow rate [L/min(ANR)]	580	
Branch/Port exhaust	600	
Air consumption [L/min(ANR)]	300	270
Supply pressure range [MPa]	0.2 to 0.6	
Operating temperature range [°C]	-5 to 50 (No freezing or condensation)	
Fluid	Air	
Vibration resistance [m/s ²]*2	20	
Impact resistance [m/s ²]*3	100	

- *1 Values are at the standard supply pressure and based on SMC's measurement standards. They depend on atmospheric pressure (weather, altitude, etc.) and the measurement method.
 *2 10 to 500 Hz for 2 hours in each direction of X, Y, and Z (De-energized, Initial value)
 *3 3 times in each direction of X, Y, and Z (De-energized, Initial value)

Supply Valve/Release Valve Specifications

	IP40	M12 connector/IP65
	ZL3-JSY3140	ZL3-V114
Response time [ms] (at 0.5 MPa)	27 or less*1	
Max. operating frequency [Hz]	5	
Manual override	Non-locking push type Push-turn locking slotted type Push-turn locking lever type	Locking slotted type
Rated coil voltage [VDC]	24	
Allowable voltage fluctuation	±10% of the rated voltage	-7 to 10% of the rated voltage
Power consumption [W]	0.4	

- *1 Based on JIS B 8419:2010 dynamic performance test (Coil temperature 20°C, at rated voltage)
 * For details on the JSY3000 and V100 series, refer to the operation manual on the SMC website.

Pressure Gauge Specifications

Model	GZ33-K1K-01-X56	GZ33-P1C-N01-X55
Pressure unit	kPa	inHg/psi dual scale
Pressure range	-100 to 100 kPa	-30 inHg to 14 psi
Connection thread	R1/8	NPT1/8
Accuracy	Vacuum ±3% F.S., Positive pressure ±5% F.S.	
Weight	30 g	

Noise Level (Reference values)^{*1, *2}

Model	ZL3	ZL6
Noise level [dB(A)]	68	

- *1 The value is for when using the silencer exhaust type with standard supply pressure and the vacuum (V) port fully open
This is an actual value under SMC's measurement conditions, not a guaranteed value.
- *2 The noise level for the port exhaust type is not listed as it varies depending on the exhaust piping conditions.

Refer to pages 34 to 37 for How to Order Replacement Parts.

Weight

Model	IP 40	
	ZL3	ZL6
Basic type	390	470
Port exhaust	+80	+25
Vacuum pressure switch (Excluding lead wire)	+20	+20
Lead wire with connector for vacuum pressure switch	+45	+45
Lead wire with connector for pressure switch with energy saving function	+50	+50
Lead wire with connector for IO-Link	+20	+20
With supply valve and release valve	+120	+120
With supply valve and without release valve	+80	+80
With pressure gauge	+30	+30
With adapter assembly for bottom mounting	+60	—

Model	IP 65	
	ZL3	ZL6
Basic type (With supply valve, release valve, and pressure switch, Silencer exhaust, Without cable)	545	610
With supply valve and without release valve	-15	-15
Port exhaust	+80	+25
Power supply/Communication cable (Socket, 2 m)	+170	+170
Communication cable (Discrete wires, 1 m)	+85	+85

Vacuum Pressure Switch Specifications

Model	ZSE10		
	Vacuum pressure switch	Compound pressure switch	Pressure switch for vacuum with energy saving function
Rated pressure range	0 to -101 kPa	-100 to 100 kPa	
Set pressure range/Display pressure range	10 to -101 kPa	-105 to 105 kPa	
Withstand pressure	500 kPa		
Smallest settable increment	0.1 kPa		
Applicable fluid	Air, Non-corrosive gas, Non-flammable gas		
Power supply voltage	12 to 24 VDC ±10%, Ripple (p-p) 10% or less (with power supply polarity protection)		
Current consumption	40 mA or less		
Switch output	NPN or PNP open collector 2 outputs (selectable)		NPN or PNP open collector OUT1: General purpose OUT2: Valve control
Max. load current	80mA		
Max. applied voltage	28 V (at NPN output)	26.4 V (at NPN output)	
Residual voltage	2 V or less (with load current of 80 mA)		
Response time	2.5 ms or less (with anti-chattering function: 20, 100, 500, 1000, 2000 ms)		
Short-circuit protection	Yes		
Repeatability	±0.2% F.S. ±1 digit		
Hysteresis	Variable (0 or above) ^{*1}		
Window comparator mode	Variable (0 or above) ^{*1}	—	
Display	3 1/2 digit, 7-segment LED, 1-color display (Red)		
Display accuracy	±2% F.S. ±1 digit (Ambient temperature of 25 ±3°C)		
Indicator light	Lights up when switch output is turned ON. OUT1: Green, OUT2: Red		
Environmental resistance	IP40		
Operating temperature range	Operating: -5 to 50°C Stored: -10 to 60°C (No freezing or condensation)		
Operating humidity range	Operating/Stored: 35 to 85% RH (No condensation)		
Withstand voltage	1000 VAC for 1 min between terminals and housing		
Insulation resistance	50 MΩ or more (500 VDC measured via megohmmeter) between terminals and housing		
Temperature characteristics	±2% F.S. ±1 digit (at 25°C in an ambient temperature of -5 and 50°C)		
Lead wire	Oilproof heavy-duty vinyl cable 5 cores Conductor area: 0.15 mm ² (AWG26) Insulator O.D.: 1.0 mm		
Standards	CE/UKCA, RoHS compliant		

*1 If the applied pressure fluctuates around the set value, the hysteresis must be set to a value more than the fluctuating width. Otherwise, chattering will occur.

* For details on the ZSE10 series, refer to the operation manual on the SMC website.

ZL3/ZL6 Series

IO-Link Compatible Vacuum Pressure Switch Specifications

IO-Link Compatible Vacuum Pressure Switch (For details, refer to the **ZL3-VP□-1-□L□□-A** operation manual on the SMC website.)

Model		ZSE10	
		For vacuum pressure	For compound pressure (Includes energy saving function)
Rated pressure range		0 to -101 kPa	-100 to 100 kPa
Set pressure range		10 to -105 kPa	-105 to 105 kPa
Proof pressure		500 kPa	
Smallest settable increment		0.1 kPa	
Power supply voltage		24 VDC ±10%, Ripple (p-p) 10% or less (with power supply polarity protection)	
Current consumption		40 mA	
Switch output	Output type	PNP open collector OUT1, OUT2: For valve control	
	Residual voltage	2 V or less (with load current of 80 mA)	
	Short-circuit protection	Yes	
Repeatability		±0.2% F.S. ±1 digit	
Hysteresis		Variable (0.1 or above)	
Display		3 1/2 digit, 7-segment LED, 1-color display (Red)	
Display accuracy		±2% F.S. ±1 digit (Ambient temperature of 25 ±3°C)	
Indicator light		Lights up when solenoid valve output is turned ON. Release valve output (OUT1): Green, Supply valve output (OUT2): Red	
Digital filter		Variable from 0 to 10 s (0.01 s increments)	
Environmental resistance	Enclosure	IP40	
	Withstand voltage	1000 VAC for 1 min between terminals and housing	
	Insulation resistance	50 MΩ or more (500 VDC measured via megohmmeter) between terminals and housing	
	Operating temperature range	Operating: -5 to 50°C, Stored: -10 to 60°C (No condensation or freezing)	
	Operating humidity range	Operating/Stored: 35 to 85% RH (No condensation)	
Temperature characteristics		±2% F.S. (25°C standard)	
Lead wire		Cable 3 cores, ø3.4, 300 mm Valve connector lead wire Insulator O.D.: 1.5 mm, 100 mm	
Communication Specifications	IO-Link type	Device	
	IO-Link version	V1.1	
	Communication speed	COM2 (38.4 kbps)	
	Configuration file	IODD file*1	
	Minimum cycle time	4.0 ms	
	Process data length	Input data: 4 bytes, Output data: 2 bytes	
	On request data communication	Yes	
	Data storage function	Yes	
	Event function	Yes	
Vendor ID	131 (0 x 0083)		

*1 The configuration file can be downloaded from the SMC website.

Internal Circuits and Wiring Examples

IP 40

■ Vacuum pressure switch NPN (2 outputs)

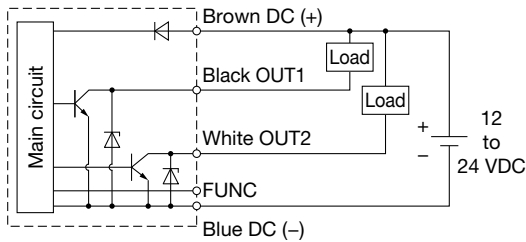

Max. 28 V, 80 mA
Residual voltage 2 V or less

* The FUNC terminal is connected when using the copy function.
(For details, refer to the Operation Manual for the ZSE10/ISE10 on the SMC website.)

PNP (2 outputs)

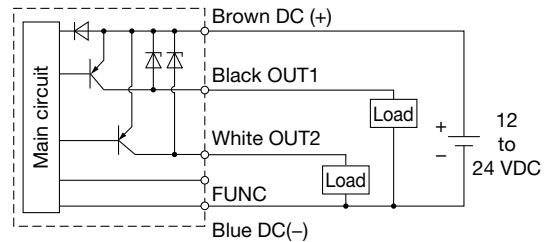

Max. 80 mA
Residual voltage 2 V or less

■ Pressure switch for vacuum with energy saving function NPN (1 output)

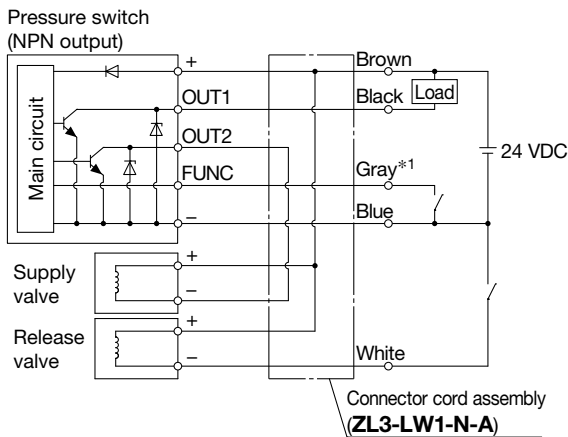

*1 When operating the supply valve using the energy-saving function (for workpiece adsorption), energize the gray wire (FUNC) for valve type K. And for valve type B, do not energize the gray wire (FUNC).
(For details, refer to the Operation Manual for the ZSE10 (For ZL3, ZL6 series) on the SMC website.)

* Connect the power supply for the vacuum ejector (pressure switch, solenoid valve) to a single power source.

PNP (1 output)

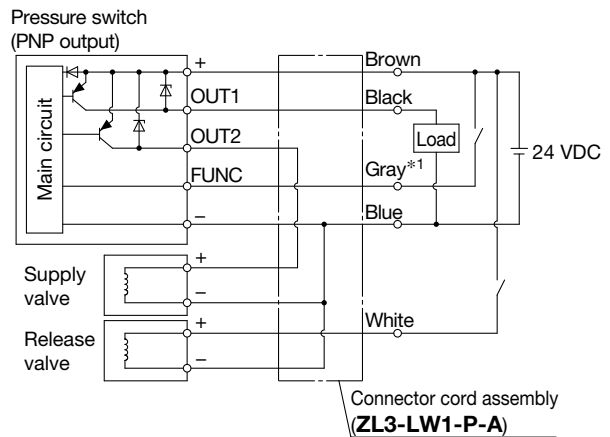

■ IO-Link compatible pressure switch

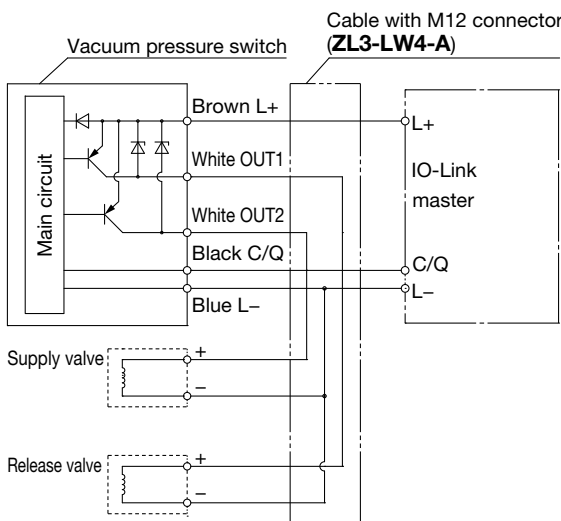

IO-Link: Process Data

Relationship between the process data and pressure value

ZL3-VP $\frac{1}{2}$ -1-EL□□-A (For 0 to -101 kPa)

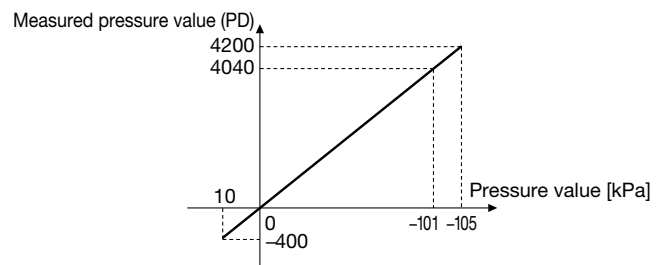

ZL3-VP $\frac{1}{2}$ -1-FL□□-A (For -100 to 100 kPa)

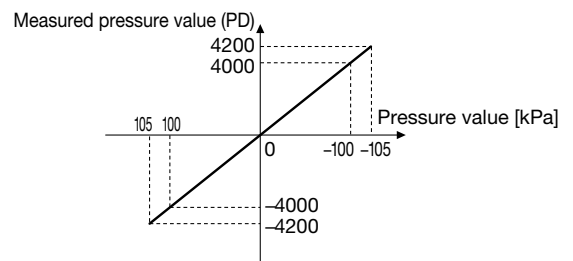

ZL3/ZL6 Series

Internal Circuits and Wiring Examples IP 65

■ Vacuum pressure switch NPN (2 outputs)

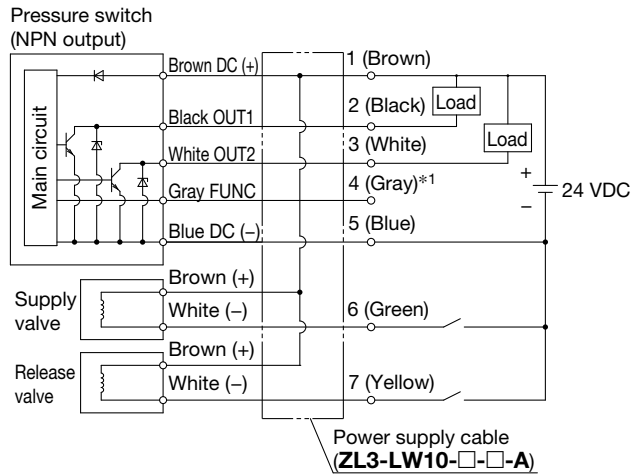

*1 The FUNC terminal is connected when using the copy function.
(For details, refer to the Operation Manual for the ZSE10/ISE10 on the SMC website.)

PNP (2 outputs)

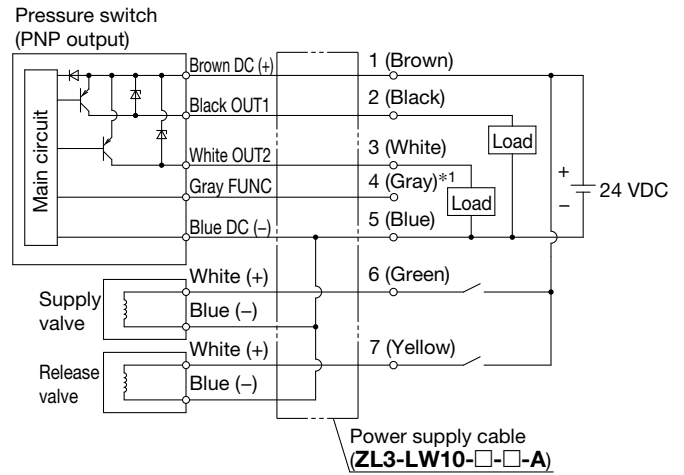

■ Pressure switch for vacuum with energy saving function NPN (1 output)

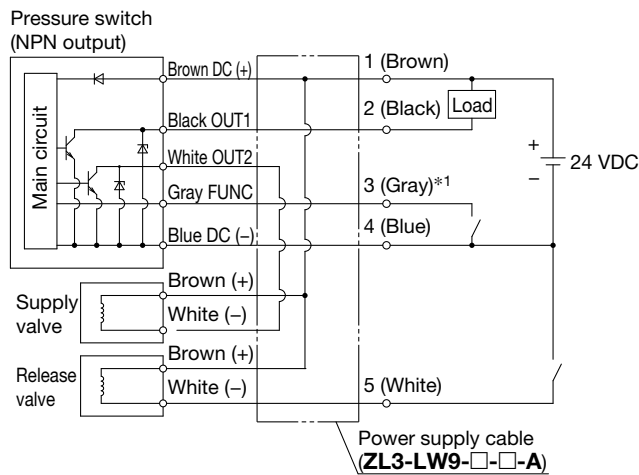

*1 When operating the supply valve using the energy-saving function (for workpiece adsorption), energize the gray wire (FUNC) for valve type K. And for valve type B, do not energize the gray wire (FUNC).
(For details, refer to the Operation Manual for the ZSE10 (For ZL3, ZL6 series) on the SMC website.)
* Connect the power supply for the vacuum ejector (pressure switch, solenoid valve) to a single power source.

PNP (1 output)

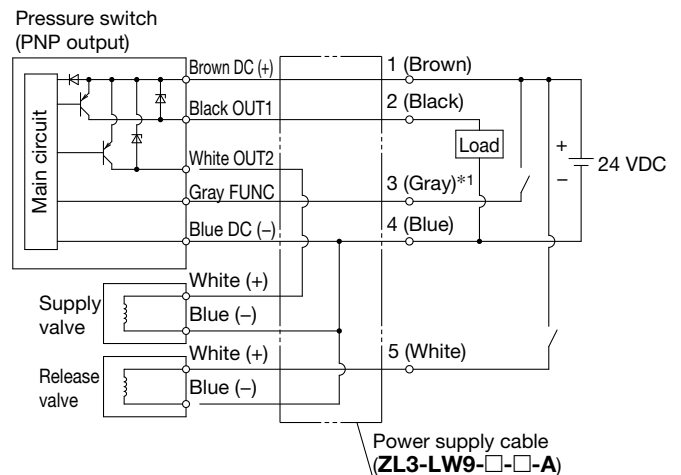

■ IO-Link compatible pressure switch

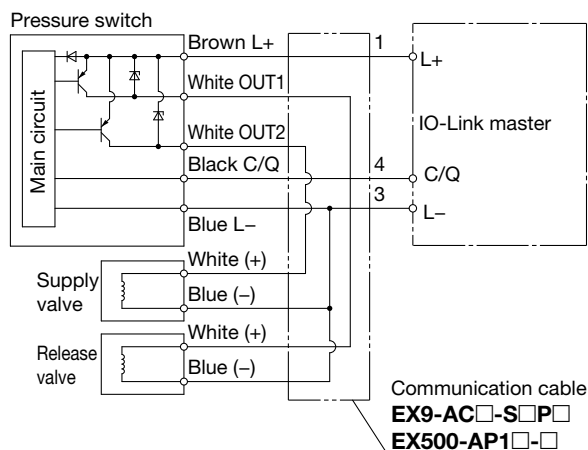

IO-Link: Process Data

Relationship between the process data and pressure value

ZL3-VP₁-1-EL□□-A
(For 0 to -101 kPa)

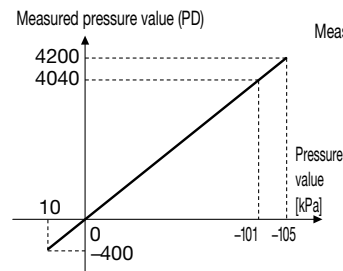

ZL3-VP₁-1-FL□□-A
(For -100 to 100 kPa)

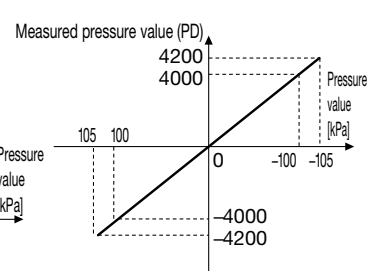

Exhaust Characteristics (Representative value)

ZL3H

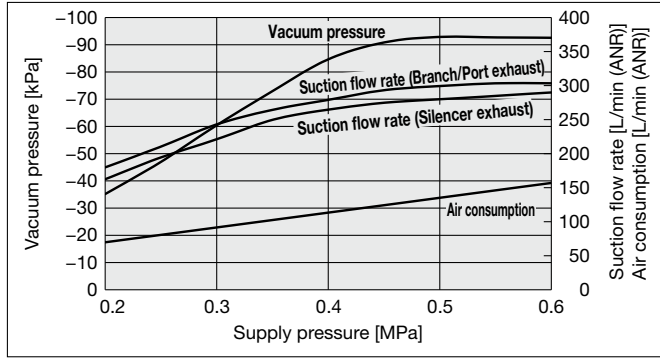

ZL3M

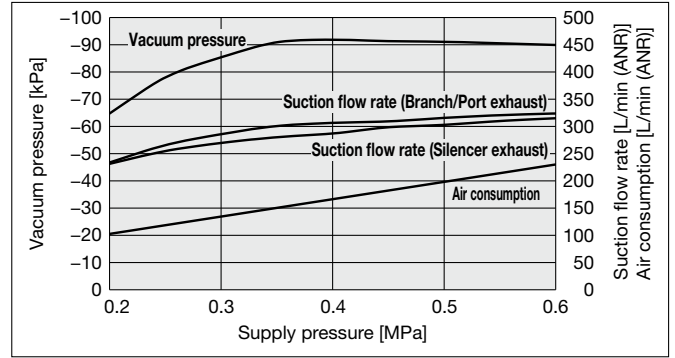

ZL6H

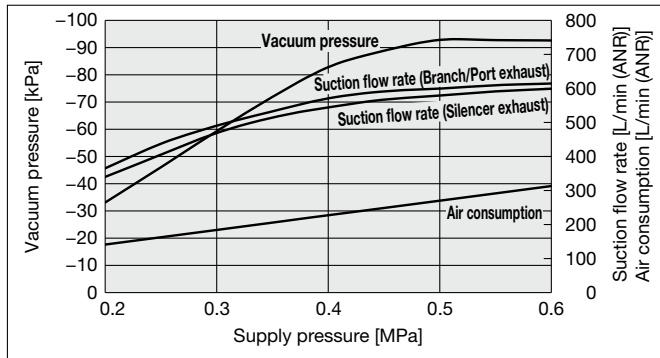

ZL6M

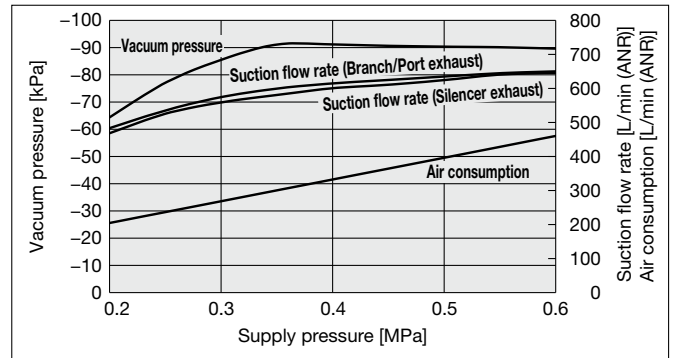

ZL6H (With valve)

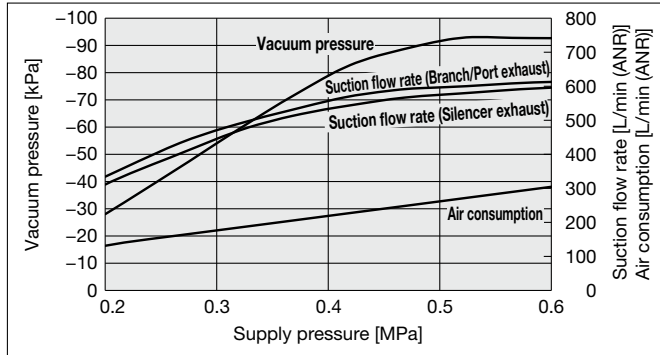

ZL6M (With valve)

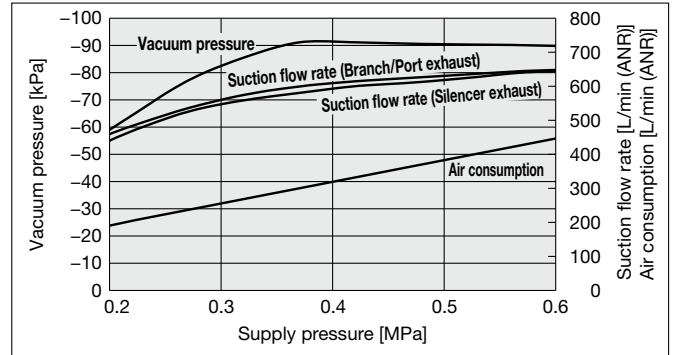

ZL1 Series

ZL3/ZL6 Series

ZL3/ZL6 Series

Flow Rate Characteristics (Representative value)

IP 40 IP 65

ZL3H (04P)

Supply pressure: 0.5 MPa

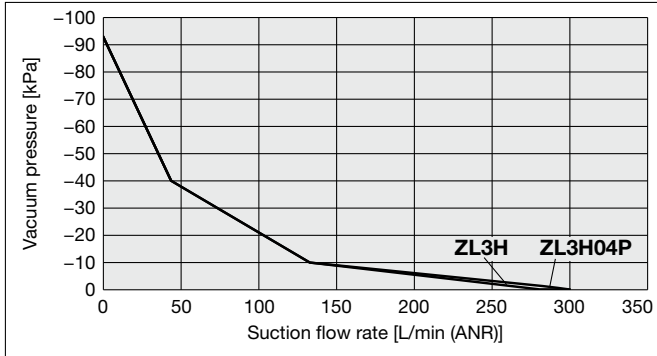

ZL3M (04P)

Supply pressure: 0.35 MPa

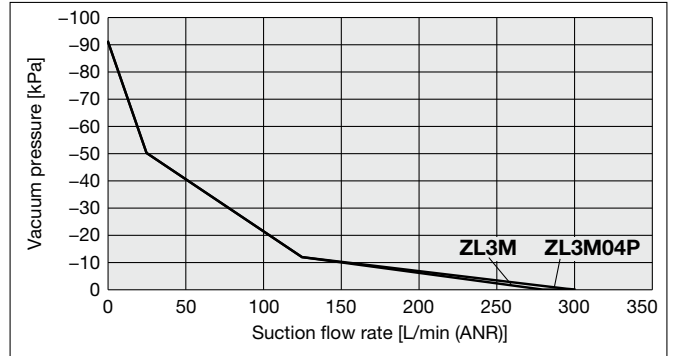

ZL6H (04P)

Supply pressure: 0.5 MPa/0.52 MPa (With valve)

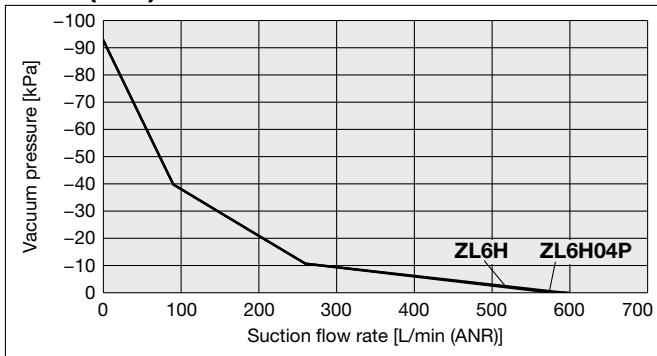

ZL6M (04P)

Supply pressure: 0.35 MPa/0.37 MPa (With valve)

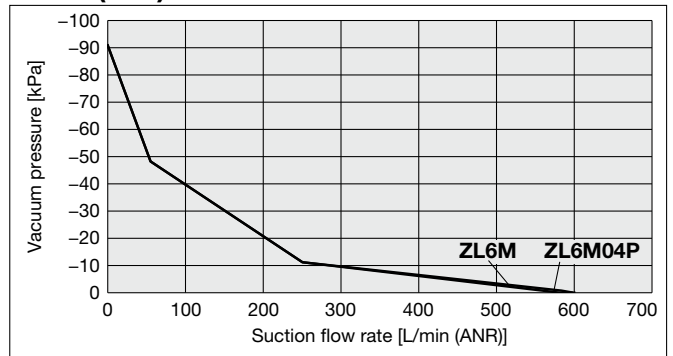

Time to Reach Vacuum (Representative value)

IP 40 IP 65

ZL3

(Tank capacity: 1 L)

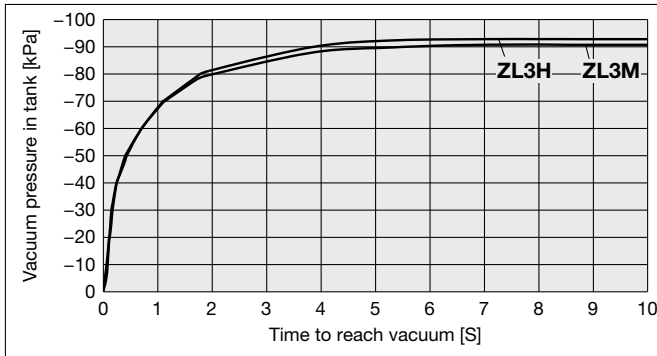

ZL6

(Tank capacity: 1 L)

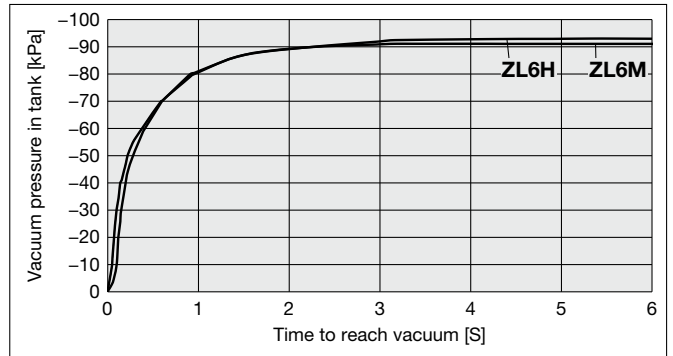

Break Flow Rate Characteristics (Representative value) IP 40

Break flow rate supplied to vacuum area at different needle openings and at each supply pressure

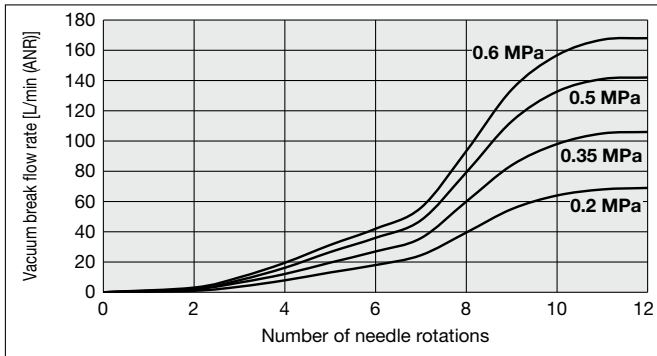

* The flow rate is not the flow rate output from the vacuum port. The break flow rate is also output on the exhaust side of the product, and the output flow rate from the vacuum port fluctuates depending on the piping conditions of the vacuum port.

Break Flow Rate Characteristics (Representative value) IP 65

Break flow rate supplied to vacuum area at different needle openings and at each supply pressure

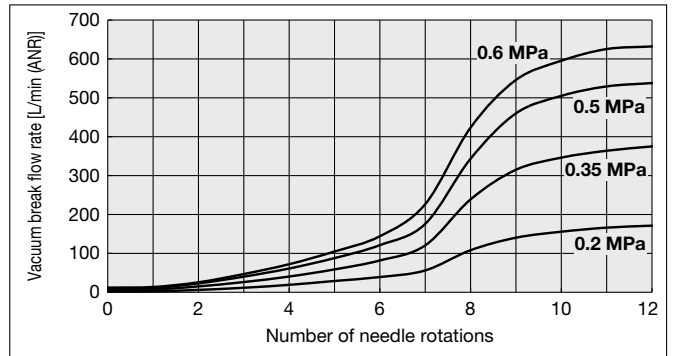

* The flow rate is not the flow rate output from the vacuum port. The break flow rate is also output on the exhaust side of the product, and the output flow rate from the vacuum port fluctuates depending on the piping conditions of the vacuum port.

Vacuum Breaking Time (Representative value) IP 40

Max. vacuum pressure → Time to reach -10 kPa (Tank capacity: 1 L)

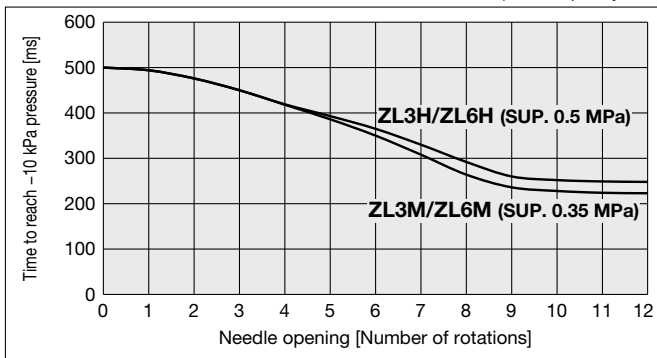

Vacuum Breaking Time (Representative value) IP 65

Max. vacuum pressure → Time to reach -10 kPa (Tank capacity: 1 L)

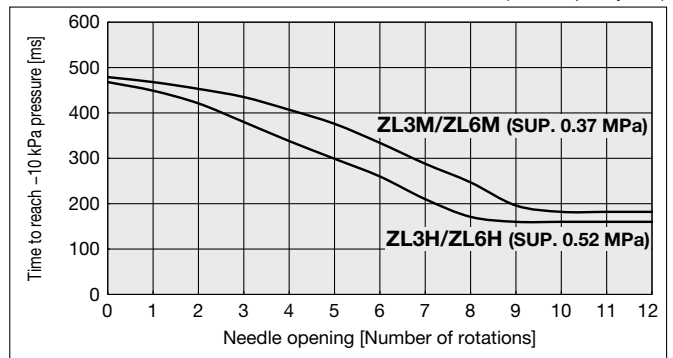

How to Read the Flow Rate Characteristics

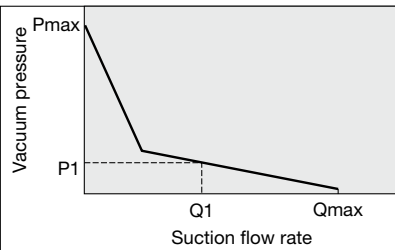

The flow rate characteristics indicate the relationship between the vacuum pressure and the suction flow rate of the ejector. They also show that when the suction flow rate changes, the vacuum pressure also changes. In general, this indicates the relationship at the ejector's standard operating pressure.

In the graph, Pmax indicates the max. vacuum pressure, and Qmax indicates the max. suction flow rate. These are the values that are published as specifications in catalogs, etc. Changes in vacuum pressure are explained below.

1. If the ejector's suction port is closed and sealed tight, the suction flow rate becomes "0," and the vacuum pressure increases to the max. (Pmax).
2. If the suction port is opened and air is allowed to flow (the air leaks), the suction flow rate increases, and the vacuum pressure decreases. (The condition of P1 and Q1)
3. If the suction port is opened completely, the suction flow rate increases to the max. (Qmax), while the vacuum pressure then drops almost to "0" (atmospheric pressure). When adsorbing workpieces which are permeable, subject to leakage, etc., caution is required as the vacuum pressure will not be very high.

How to Read the Time to Reach Vacuum

The graphs indicate the time required to reach a vacuum pressure determined by adsorption conditions for workpieces, etc., starting from atmospheric pressure in a 1 L sealed tank. For the ZL3H, approximately 4.0 seconds are necessary to attain a vacuum pressure of -90 kPa.

ZL3/ZL6 Series

Construction

IP40 specification

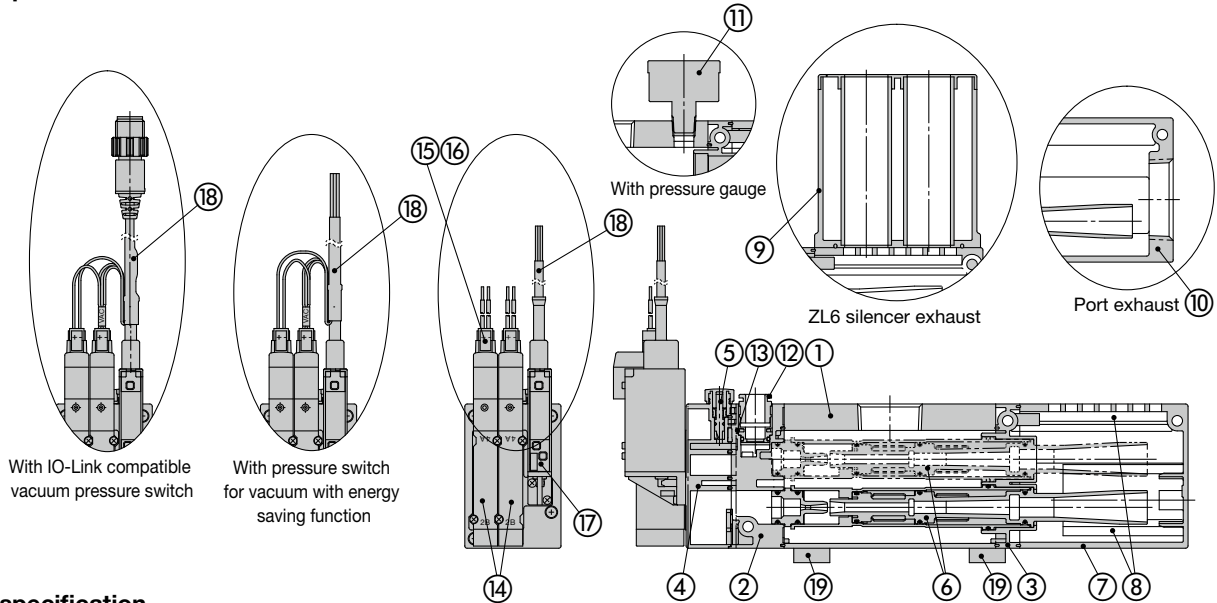

IP65 specification

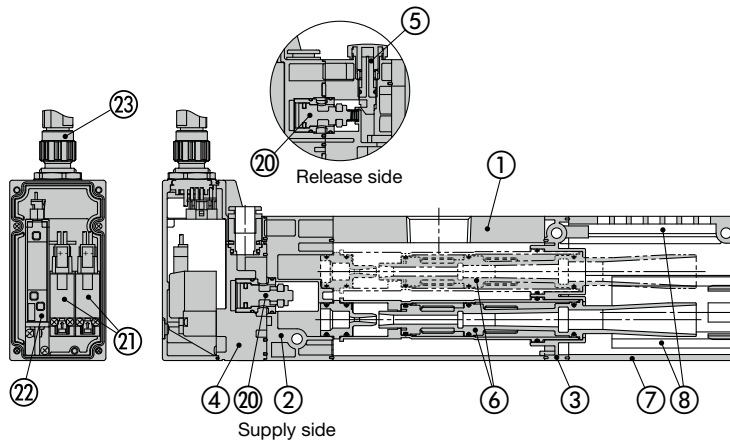

Component Parts and Replacement Parts

No.	Description	Material	Note
1	Body	Aluminum alloy (Anodized)	—
2	Front adapter	PBT	—
3	End adapter	PBT	—
4	Valve plate	PBT	—
5	Needle assembly	POM/PBT/Brass (Electroless nickel plating)	—
6	Ejector assembly	PBT/POM/FKM/NBR	Refer to 5 on page 35 for replacement parts.
7	Silencer assembly (For ZL3)	PBT/Resin/Non-woven fabric	Refer to 6 on page 35 for replacement parts.
8	Sound absorbing material assembly	Resin/Non-woven fabric	Refer to 7 on page 35 for replacement parts.
9	Silencer assembly (For ZL6)	PBT/POM/Non-woven fabric	Refer to 8 on page 35 for replacement parts.
10	Exhaust block assembly	Aluminum alloy (Chromated, Painted)	Refer to 9 on page 35 for replacement parts.
11	Pressure gauge	—	Refer to 10 on page 35 for replacement parts.
12	One-touch fitting assembly	—	Refer to 13 on page 36 for replacement parts.
13	Clip	—	Refer to 14 on page 36 for replacement parts.
14	Supply valve, Release valve	—	Refer to 1 on page 34 for replacement parts.
15	Lead wire with connector assembly for supply valve/release valve	—	Refer to 2 on page 34 for replacement parts.
16	Connector and socket for supply valve/release valve	—	Refer to 3 on page 34 for replacement parts.
17	Vacuum pressure switch	—	Disassembly is not possible. Vacuum pressure switch replacement assembly (Refer to 12 on page 36.)
18	Lead wire with connector for vacuum pressure switch	—	Refer to 4 on page 34 for replacement parts.
19	Adapter assembly for bottom mounting	Brass (Electroless nickel plating)	Refer to 11 on page 35 for replacement parts.
20	Supply valve/Release valve assembly	POM/HNBR/Stainless steel	—
21	Supply valve, Release valve	—	Refer to 1 on page 34 for replacement parts.
22	Vacuum pressure switch	—	Disassembly is not possible. Vacuum pressure switch replacement assembly (Refer to 12 on page 36.)
23	Power supply/Communication cable	—	Refer to page 45 for the communication cable.
—	Seal material (O-ring, etc.)	HNBR/NBR	—
—	Screws for assembly	Steel (Trivalent chromated)	—

* The silencer part is not compliant with IP65.

How to Order Replacement Parts

1 Supply Valve/Release Valve (For ZL3/ZL6)

IP 40

ZL3-JSY3140-5 L Z - [] - []

Rated voltage 24 VDC ① ② ③

With light/surge voltage suppressor

Supply valve/Release valve
* With 2 mounting screws

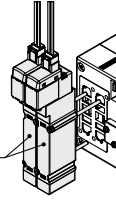

① Electrical entry

L plug connector		M plug connector	
L	LO	M	MO
L: With lead wire (300 mm)	LO: Without connector	M: With lead wire (300 mm)	MO: Without connector

② Manual override

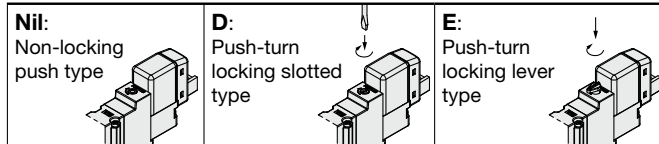

③ Supply valve/Release valve

Nil	Supply valve
X12	Release valve

IP 65

ZL3-V114-5MOZB - [] - A

Nil	Supply valve
X755	Release valve

Supply valve/Release valve
* With 2 mounting screws

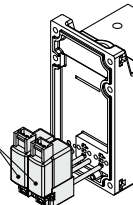

2 Lead Wire with Connector Assembly for Supply Valve/Release Valve (For ZL3/ZL6)

IP 40

SY100-30-4 A - ⑥

Rated voltage 24 VDC

Lead wire with connector assembly for supply valve and release valve

① Lead wire length

Nil	300 mm	20	2000 mm
6	600 mm	25	2500 mm
10	1000 mm	30	3000 mm
15	1500 mm	50	5000 mm

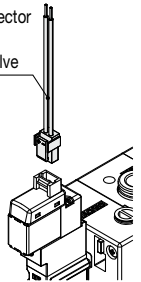

3 Connector and Socket for Supply Valve/Release Valve (For ZL3/ZL6)

IP 40

SY100-30-A

* With connector and 2 sockets only

4 Lead Wire with Connector for Vacuum Pressure Switch (For ZL3/ZL6)

IP 40

(When an individual lead wire is necessary, order with the part number below.)

• Lead wire with connector for vacuum pressure switch

ZS-39-5G

Lead wire with connector for vacuum pressure switch

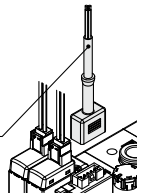

• Lead wire with connector for switch with energy saving function

ZL3-LW1-N - A

① Output

N	NPN open collector
P	PNP open collector

Lead wire with connector for switch with energy saving function

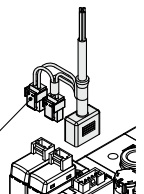

• Lead wire with connector for IO-Link compatible vacuum pressure switch (With M12 connector)

ZL3-LW4-A

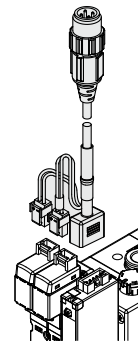

ZL3/ZL6 Series

How to Order Replacement Parts

5 Ejector Assembly (For ZL3/ZL6) IP 40 IP 65

ZL3 – EJ1 – H – A

① ②

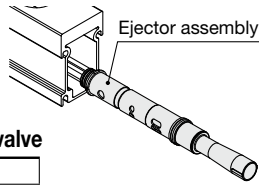

① Standard supply pressure ② 1-stage check valve

M	0.35 MPa
H	0.50 MPa

Nil	None
V	Yes

A 1-stage check valve is required for specifications with pressure switches with an energy saving function.

6 Silencer Assembly (With sound absorbing material) (For ZL3) IP 40 IP 65

ZL3 – SC1 – A

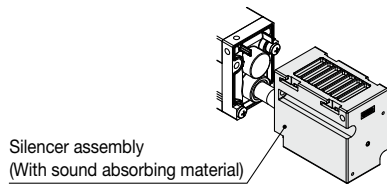

Silencer assembly
(With sound absorbing material)

7 Sound Absorbing Material Assembly (For ZL3) IP 40 IP 65

ZL3 – SE1 – A

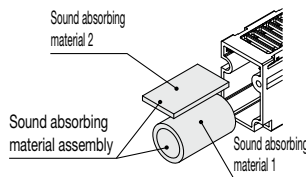

* Sound absorbing material 1 and 2, 1 pc. each/set

8 Silencer Assembly (With sound absorbing material) (For ZL6) IP 40 IP 65

ZL6 – SC1 – A

Silencer assembly
(With sound absorbing material)

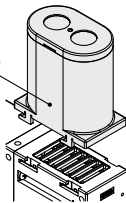

9 Exhaust Block Assembly (For ZL3/ZL6) IP 40 IP 65

ZL3 – EP1 – 1 – A

①

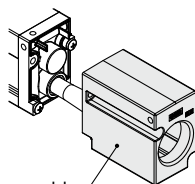

Exhaust block assembly

① Thread type

Nil	Rc thread
F	G thread
N	NPT thread

10 Pressure Gauge (For ZL3/ZL6) IP 40

GZ33 – K1K – 01 – X56
(Displayed in kPa)

GZ33 – P1C – N01 – X55
(Displayed in inHg·psi)^{*1}

*1 Under the New Measurement Act, products with inHg·psi unit specifications are not permitted for use in Japan.

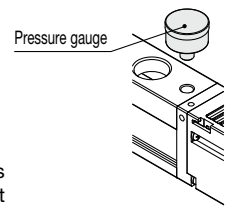

Pressure gauge

11 Adapter Assembly for Bottom Mounting (For ZL3) IP 40

ZL3 – AD3 – A

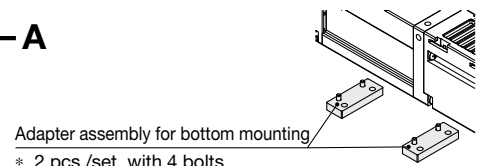

Adapter assembly for bottom mounting

* 2 pcs./set, with 4 bolts

For mounting interchangeability with the discontinued ZL212 series

How to Order Replacement Parts

12 Vacuum Pressure Switch Replacement Assembly IP 40

For the type without a valve

ZL3-AD1-2 - EA M G - A

1
 2
 3
 4

1 Supply (1/P) port applicable tubing O.D.

Nil	8 (Metric)
N	5/16" (Inch)

2 Vacuum pressure sensor

Symbol	Pressure range [kPa]	Output
EA	0 to -101	NPN 2 outputs
EB		PNP 2 outputs
FA	-100 to 100	NPN 2 outputs
FB		PNP 2 outputs

3 Unit

Nil	With unit switching function
M	SI unit only (kPa)
P	With unit switching function (Initial value psi)

4 Lead wire

Nil	Without lead wire with connector
G	Lead wire with connector (Length: 2 m) (Included)

Under the New Measurement Act, switches with the unit switching function are not permitted for use in Japan (implemented October 1999).

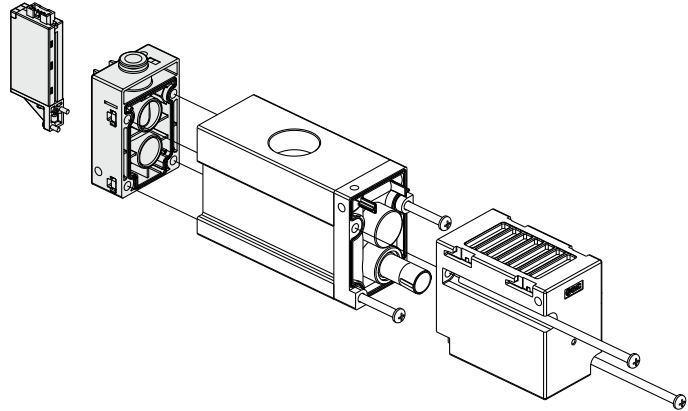

For the type with a valve

ZL3-VP 1 - 1 - FL M H - A

1
 2
 3
 4
 5

1 Supply valve

1	N.C.
2	N.O.

2 Release valve

1	With release valve
2	Without release valve

3 Vacuum pressure sensor

Symbol	Pressure range [kPa]	Output
EA	0 to -101	NPN 2 outputs
EB		PNP 2 outputs
FA	-100 to 100	NPN 2 outputs
FB		PNP 2 outputs
VA*1	-100 to 100	NPN 1 output + Energy saving control
VB*1		PNP 1 output + Energy saving control
EL*1	0 to -101	IO-Link
FL*1	-100 to 100	IO-Link (Includes energy saving function)

*1 This option cannot be selected if "2" is selected for **2**.

4 Unit

Nil*2	With unit switching function
M	SI unit only (kPa)
P*2, *3	With unit switching function (Initial value psi)

*2 Under the New Measurement Act, switches with the unit switching function are not permitted for use in Japan (implemented October 1999).

*3 This option cannot be selected if "VA," "VB," "EL," or "FL" is selected for **3**.

5 Lead wire

Nil	Without lead wire with connector
G	Lead wire with connector (Length: 2 m) (Included)
W	Lead wire for switch with energy saving function (Length: 2 m) (Included)
H	Lead wire with connector for IO-Link compatible vacuum pressure switch (With M12 connector, Length: 300 mm) (Included)

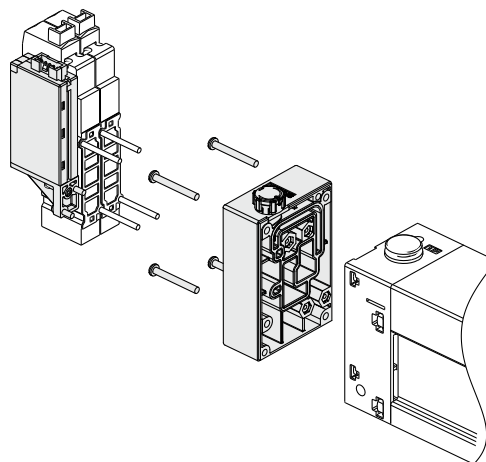

13 One-touch fitting assembly (Purchasing order is available in units of 10 pieces.) IP 40

VVQ1000-51A-

1

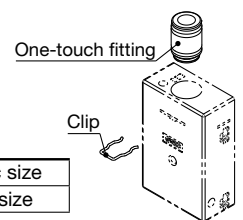

1 Port size

C8	ø8 One-touch fitting	Metric size
N9	ø5/16" One-touch fitting	Inch size

14 Clip (Purchasing order is available in units of 10 pieces.) IP 40

VQZ3000-20-1

ZL3/ZL6 Series

How to Order Replacement Parts

15 Vacuum Pressure Switch Replacement Assembly

IP 65

How to Order

ZL3-PL **3** - **1** **3** - **EL** **M** J-A

1
 2 3
 4 5

1 Supply valve

3	N.C.
4	N.O.

2 Release valve

1	With release valve
2	Without release valve

3 Applicable tubing size

Nil	Metric size
N	Inch size

4 Vacuum pressure sensor

Symbol	Pressure range [kPa]	Output
EA	0 to -101	NPN 2 outputs
EB		PNP 2 outputs
FA	-100 to 100	NPN 2 outputs
FB		PNP 2 outputs
VA*1		NPN 1 output + Energy saving control
VB*1		PNP 1 output + Energy saving control
EL*1	0 to -101	IO-Link
FL*1	-100 to 100	IO-Link (Includes energy saving control)

*1 This option cannot be selected if "2" is selected for the 2 release valve.

5 Unit

Nil*2	With unit switching function
M	SI unit only (kPa)
P*2, *3	With unit switching function (Initial value psi)

*2 Under the New Measurement Act, switches with the unit switching function are not permitted for use in Japan (implemented October 1999).

*3 This option cannot be selected if "VA," "VB," "EL," or "FL" is selected for the 4 vacuum pressure sensor.

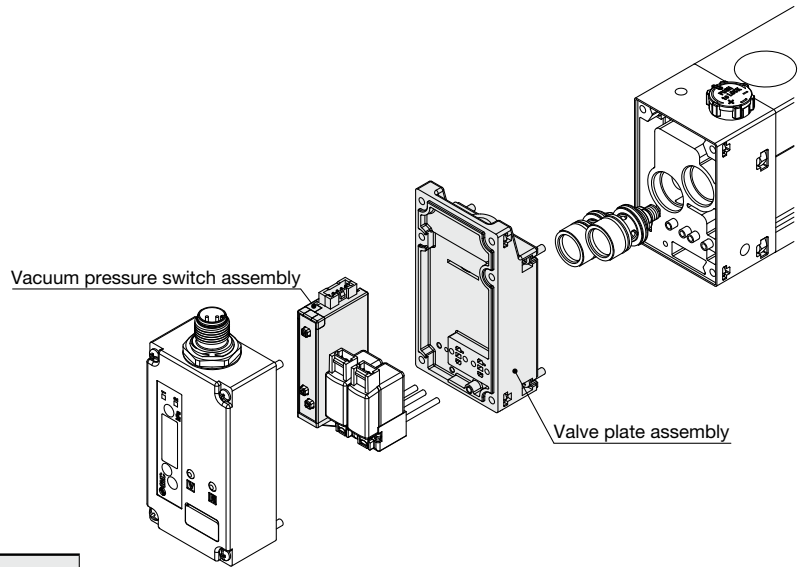

Multistage Ejector **ZL3/ZL6 Series**

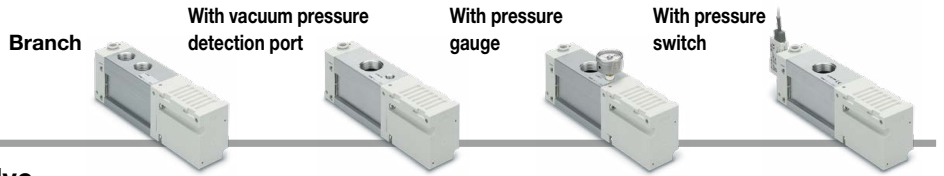

Dimensions

ZL3□□□-□□□□-□ Without valve

Air pressure supply (1/P) port applicable tubing O.D.

	A	Release button color
ZL3□□	8	Light gray
ZL3□N□	5/16"	Orange

Air pressure supply (1/P) port
Applicable tubing O.D. **A**

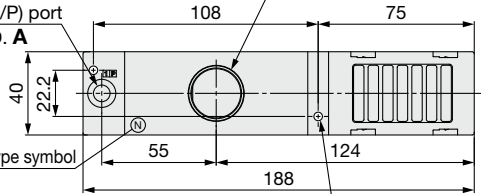

Vacuum (2/V) port thread type symbol

Nil: Rc thread
F: G thread
N: NPT thread

Vacuum (2/V) port*1
Rc3/4, G3/4*5, NPT3/4
(Recommended tightening torque: 28 to 30 N·m)

2 x $\phi 4.1$ Mounting hole*3
(Recommended tightening torque: 0.56 to 0.76 N·m)

ZL3 Without valve

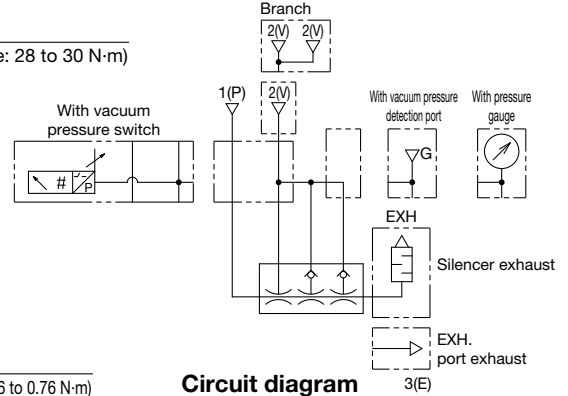

Circuit diagram

Exhaust port thread type symbol

Nil: Rc thread
F: G thread
N: NPT thread

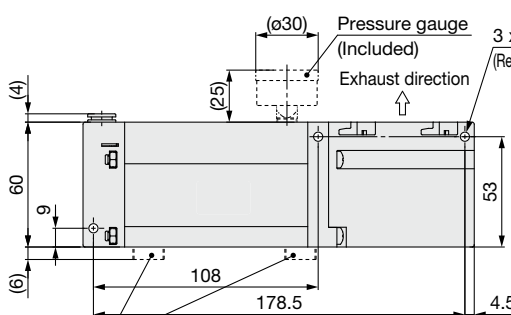

Adapter assembly for bottom mounting
(Included)

4 x M3 x 0.5
Thread depth 5 (Mounting hole)*3
(Recommended tightening torque: 0.29 to 0.31 N·m)

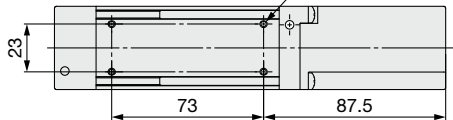

4 x M5 x 0.8
Thread depth 6 (Mounting hole)*3
(Recommended tightening torque: 1.3 to 1.5 N·m)

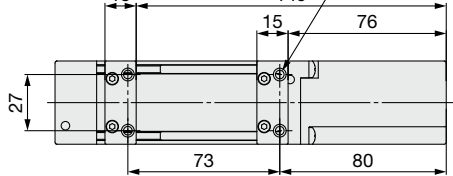

Options

Branch

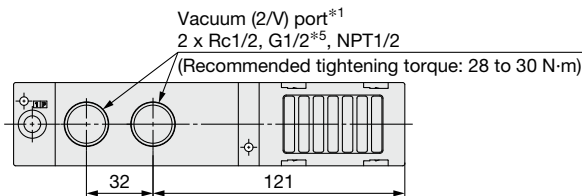

With vacuum pressure detection port

* Refer to the vacuum port figure above for the branch specification.

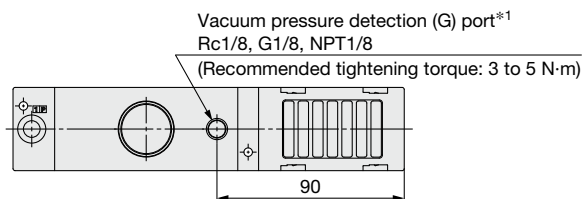

With pressure gauge

* Refer to the vacuum port figure above for the branch specification.

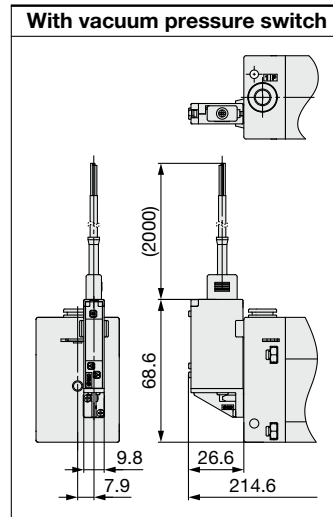
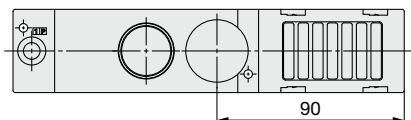

*1 To connect piping to the vacuum port and vacuum pressure detection port, hold the aluminum alloy body, then connect the piping.

*2 Hold the exhaust block when connecting piping to the exhaust port.

It is recommended that piping with an inner diameter of 21.7 or more be used.

*3 Tighten to the recommended torque to mount the body. Tightening with excessive force may damage the product.

*4 These holes are required for the forming of the product. They are not exhaust ports.

*5 The thread ridge shape is in compliance with G thread standard ISO 228-1, but the other shapes are not in compliance with ISO 16030 or ISO 1179. Use a male thread with a length of 10.5 or less for the vacuum port and 11.5 or less for the exhaust port for connection.

ZL3/ZL6 Series

With pressure switch for vacuum with energy saving function

With supply valve and release valve

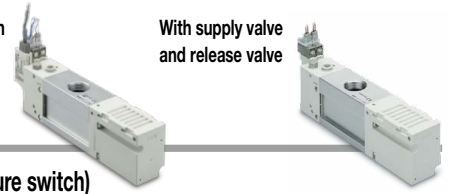

Dimensions

ZL3□□□-K₁B₁ 5□Z□-E□□□ With valve (With supply valve, release valve and vacuum pressure switch)

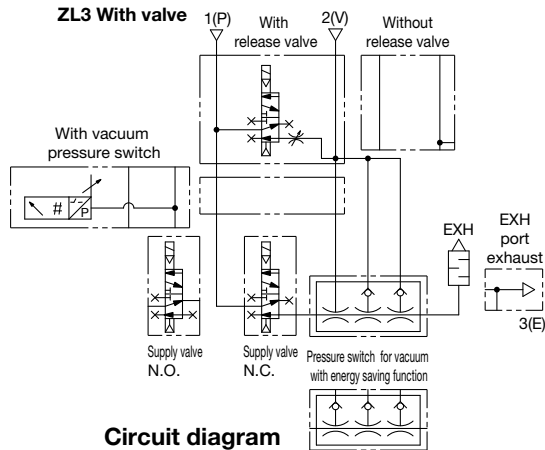
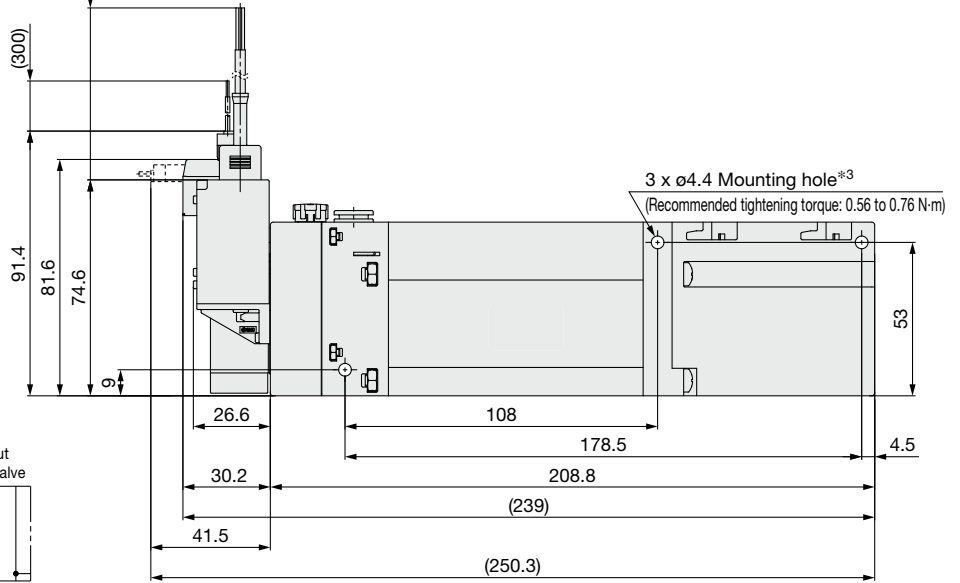
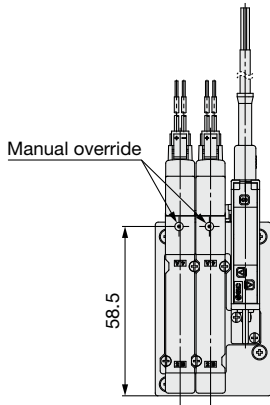
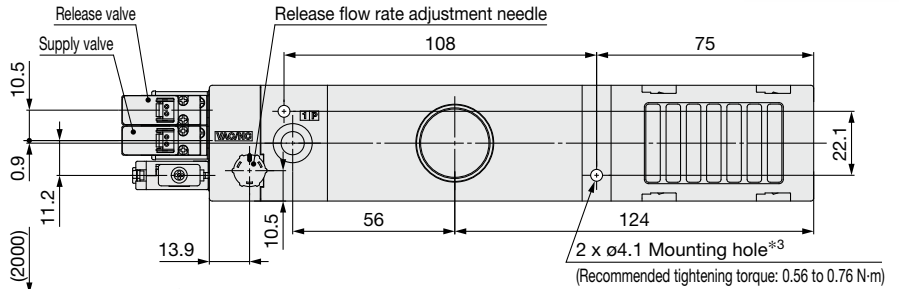

Circuit diagram

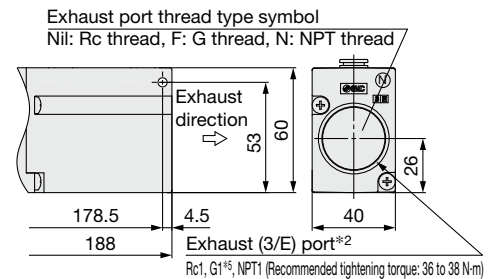

Port exhaust

ZL3□□□-K ₂ B ₂ 5□Z□-E□□□	ZL3□□□-K ₂ B ₂ 5□Z□	ZL3□□□-K ₁ B ₁ 5□Z□	ZL3□□□-K ₁ B ₁ 5LOZ-V□□W	ZL3□□□-K ₁ B ₁ 5LOZ-□L□H
With supply valve and vacuum pressure switch	With supply valve	With supply valve and release valve	With pressure switch for vacuum with energy saving function	With IO-Link compatible vacuum pressure switch



Dimensions Refer to page 46 for details on the connector for the vacuum pressure switch.

ZL3□□□-□5MOZB-□□□J□ (With supply valve, release valve, and pressure switch)

Table 1. Air pressure supply (1/P) port applicable tubing O.D.

	A	Release button color
ZL3□□□	8	Light gray
ZL3□□F□		
ZL3□□N□	5/16"	Orange

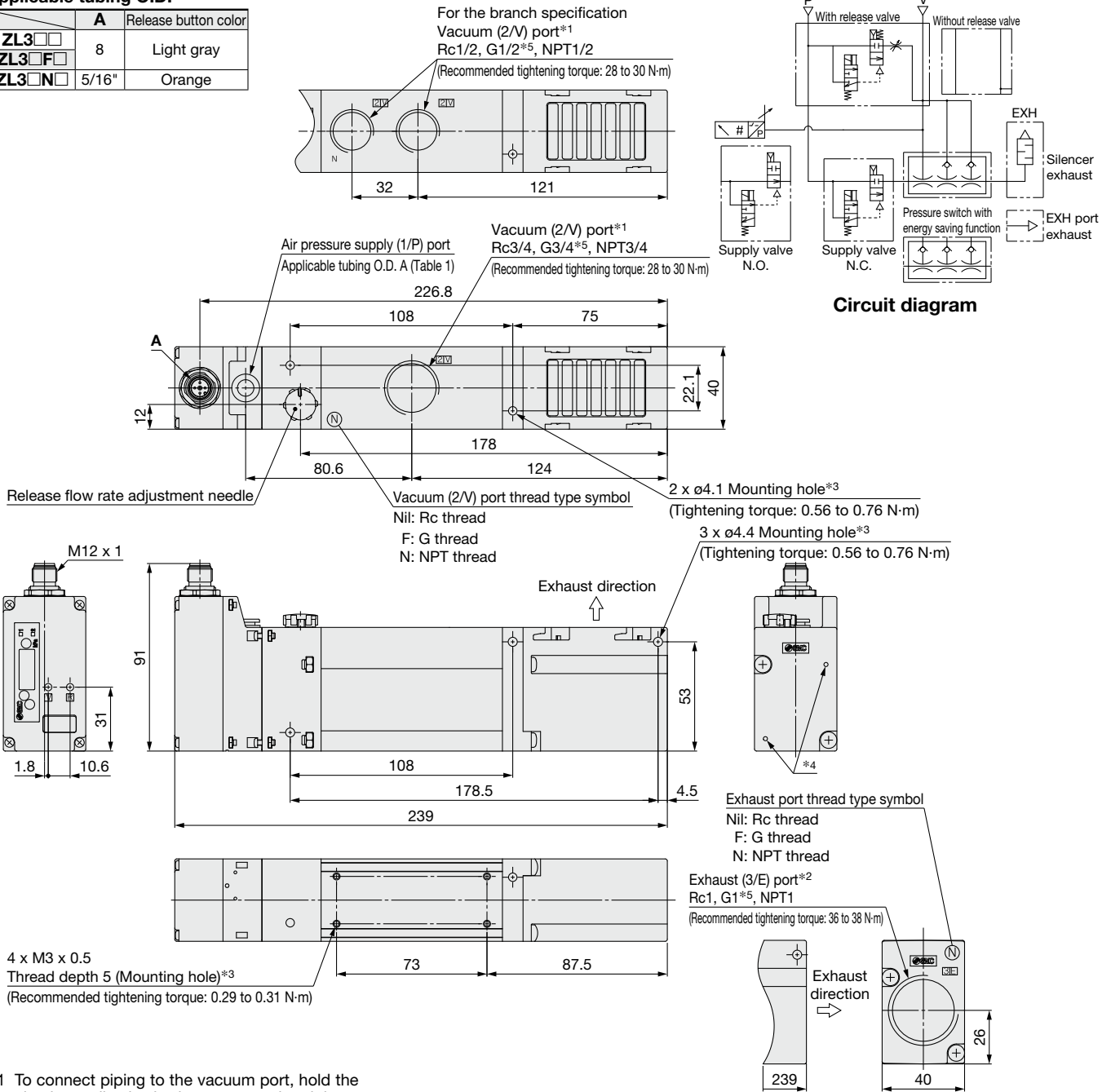

Circuit diagram

Communication cable

For the vacuum pressure switch/
pressure switch for vacuum with energy saving function

Straight connector type

Angled connector type

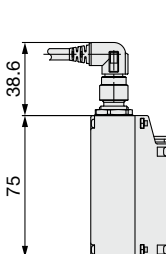
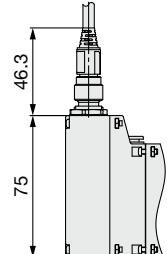

For the IO-Link compatible vacuum pressure switch

Straight connector type

Angled connector type

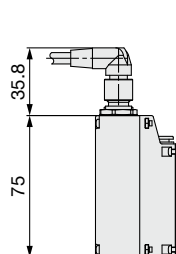
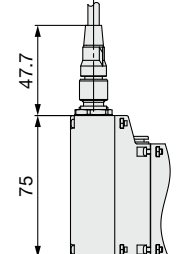

- *1 To connect piping to the vacuum port, hold the aluminum alloy body, then connect the piping.
- *2 Hold the exhaust block when connecting piping to the exhaust port. It is recommended that piping with an inner diameter of 21.7 or more be used.
- *3 Tighten to the recommended torque to mount the body. Tightening with excessive force may damage the product.
- *4 These holes are required for the forming of the product. They are not exhaust ports.
- *5 The thread ridge shape is in compliance with G thread standard ISO 228-1, but the other shapes are not in compliance with ISO 16030 or ISO 1179. Use a male thread with a length of 10.5 or less for the vacuum port and 11.5 or less for the exhaust port for connection.

ZL3/ZL6 Series

Dimensions

ZL6□□□□-□□□□ Without valve

Air pressure supply (1/P) port applicable tubing O.D.

	A	Release button color
ZL6□□□□	8	Light gray
ZL6□N□□□	5/16"	Orange

Air pressure supply (1/P) port
Applicable tubing O.D. A

Vacuum (2/V) port thread type symbol
Nil: Rc thread
F: G thread
N: NPT thread

2 x $\phi 4.1$ Mounting hole*3
(Recommended tightening torque: 0.56 to 0.76 N·m)

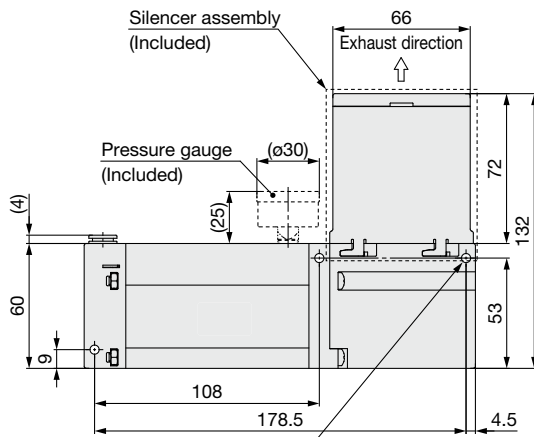
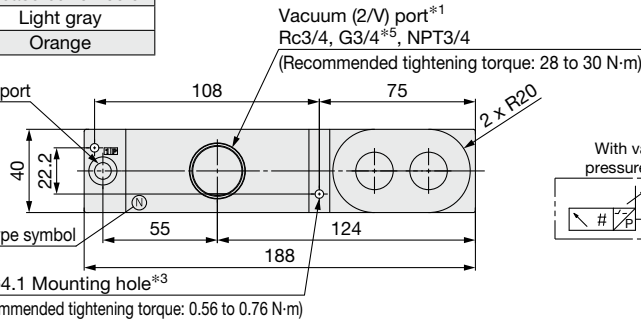

3 x $\phi 4.4$ Mounting hole*3
(Recommended tightening torque: 0.56 to 0.76 N·m)

4 x M3 x 0.5
Thread depth 5 (Mounting hole)*3
(Recommended tightening torque: 0.29 to 0.31 N·m)

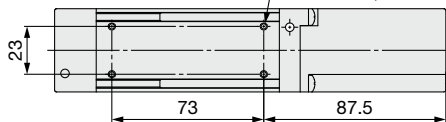

Options

Branch

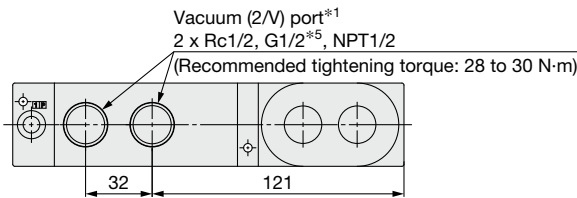

With vacuum pressure detection port

* Refer to the vacuum port figure above for the branch specification.

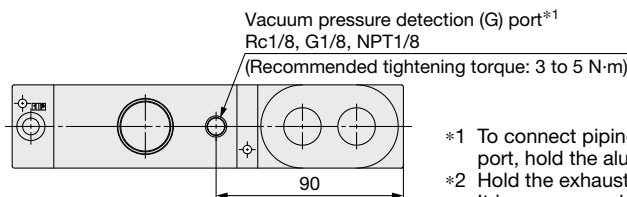

With pressure gauge

* Refer to the vacuum port figure above for the branch specification.

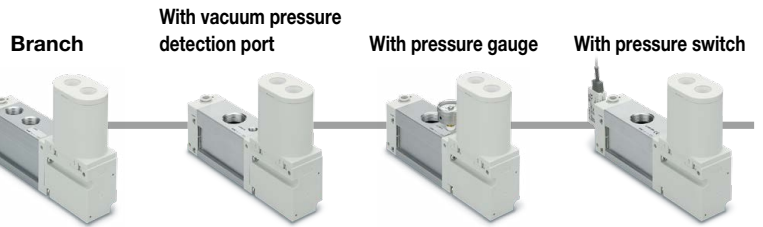
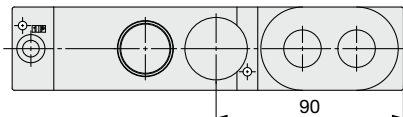

ZL6 Without valve

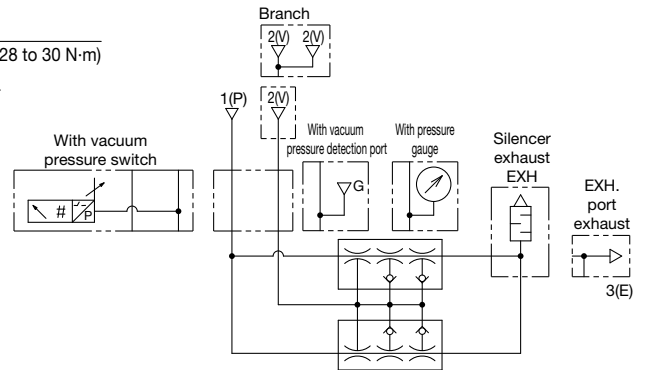

Circuit diagram

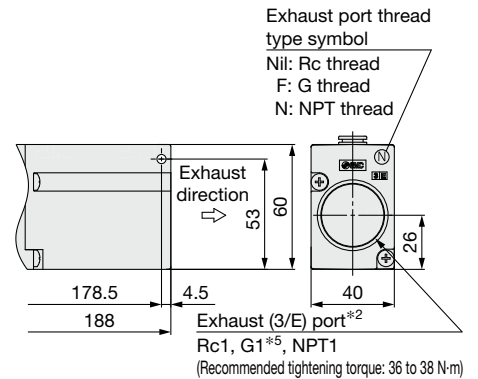

Port exhaust

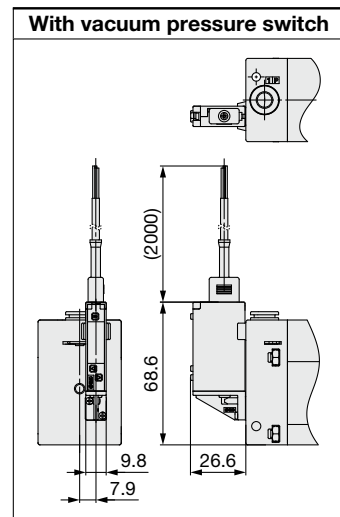

- *1 To connect piping to the vacuum port and vacuum pressure detection port, hold the aluminum alloy body, then connect the piping.
- *2 Hold the exhaust block when connecting piping to the exhaust port. It is recommended that piping with an inner diameter of 21.7 or more be used.
- *3 Tighten to the recommended torque to mount the body. Tightening with excessive force may damage the product.
- *4 These holes are required for the forming of the product. They are not exhaust ports.
- *5 The thread ridge shape is in compliance with G thread standard ISO 228-1, but the other shapes are not in compliance with ISO 16030 or ISO 1179. Use a male thread with a length of 10.5 or less for the vacuum port and 11.5 or less for the exhaust port for connection.

Multistage Ejector **ZL3/ZL6 Series**

Pressure switch for vacuum with energy saving function

With supply valve and release valve

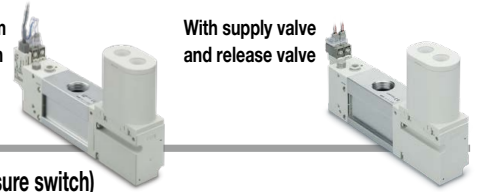

Dimensions

ZL6□□□-^{K1}_{B1} 5□Z□-^E□□□ With valve (With supply valve, release valve, and vacuum pressure switch)

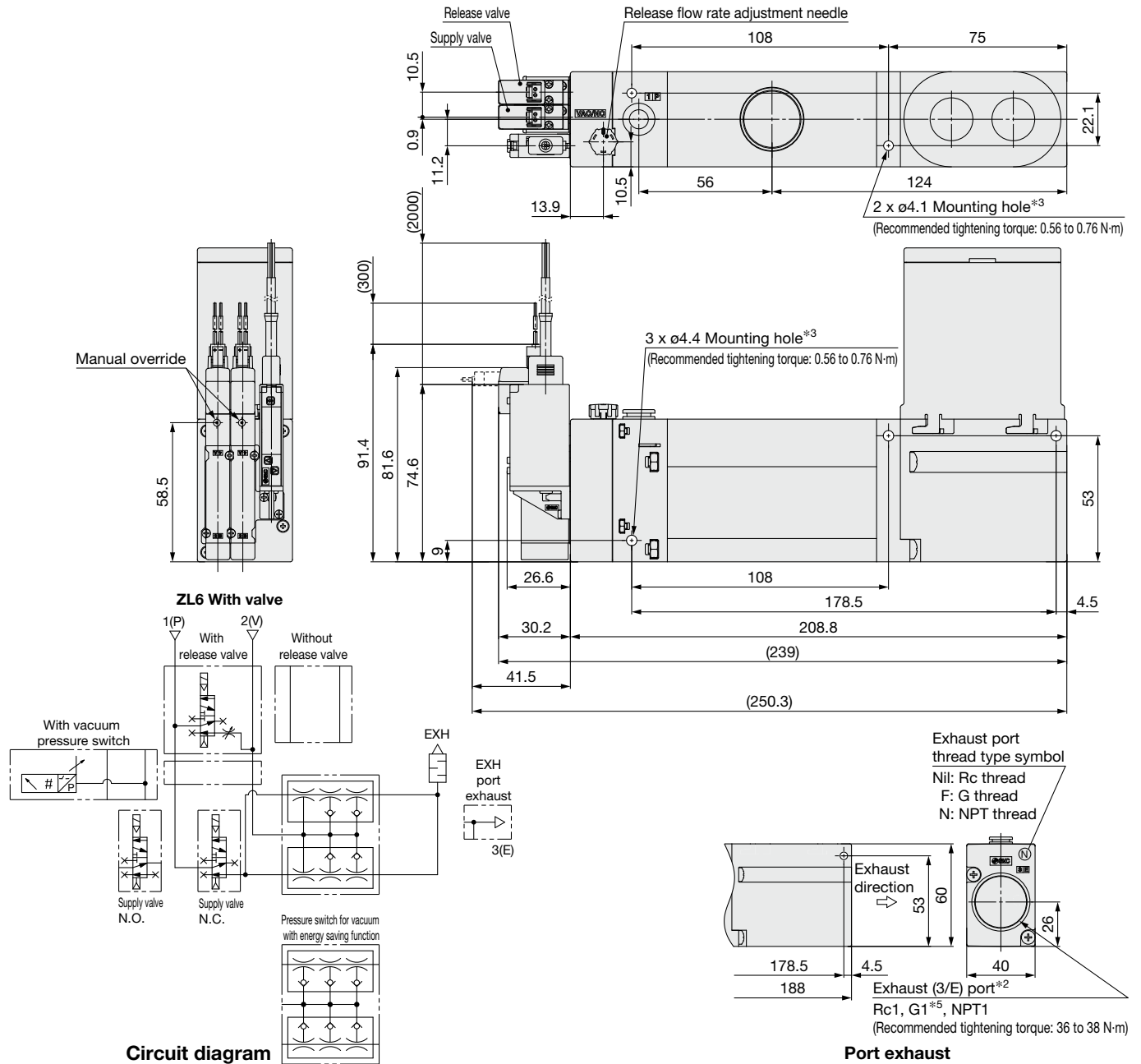

ZL1 Series

ZL3/ZL6 Series

ZL6□□□- ^{K2} _{B2} 5□Z□- ^E □□□	ZL6□□□- ^{K2} _{B2} 5□Z□	ZL6□□□- ^{K1} _{B1} 5□Z□	ZL6□□□- ^{K1} _{B1} 5LOZ-V□□W	ZL6□□□- ^{K1} _{B1} 5LOZ-□□□H
With supply valve and vacuum pressure switch	With supply valve	With supply valve and release valve	With pressure switch for vacuum with energy saving function	With IO-Link compatible vacuum pressure switch

ZL3/ZL6 Series



Dimensions Refer to page 46 for details on the connector for the vacuum pressure switch.

ZL6□□□-□5MOZB-□□□J□ (With supply valve, release valve, and pressure switch)

Table 1. Air pressure supply (1/P) port applicable tubing O.D.

	A	Release button color
ZL6□□	8	Light gray
ZL6□F□		
ZL6□N□	5/16"	Orange

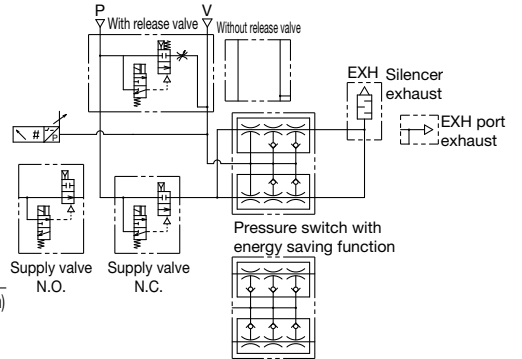
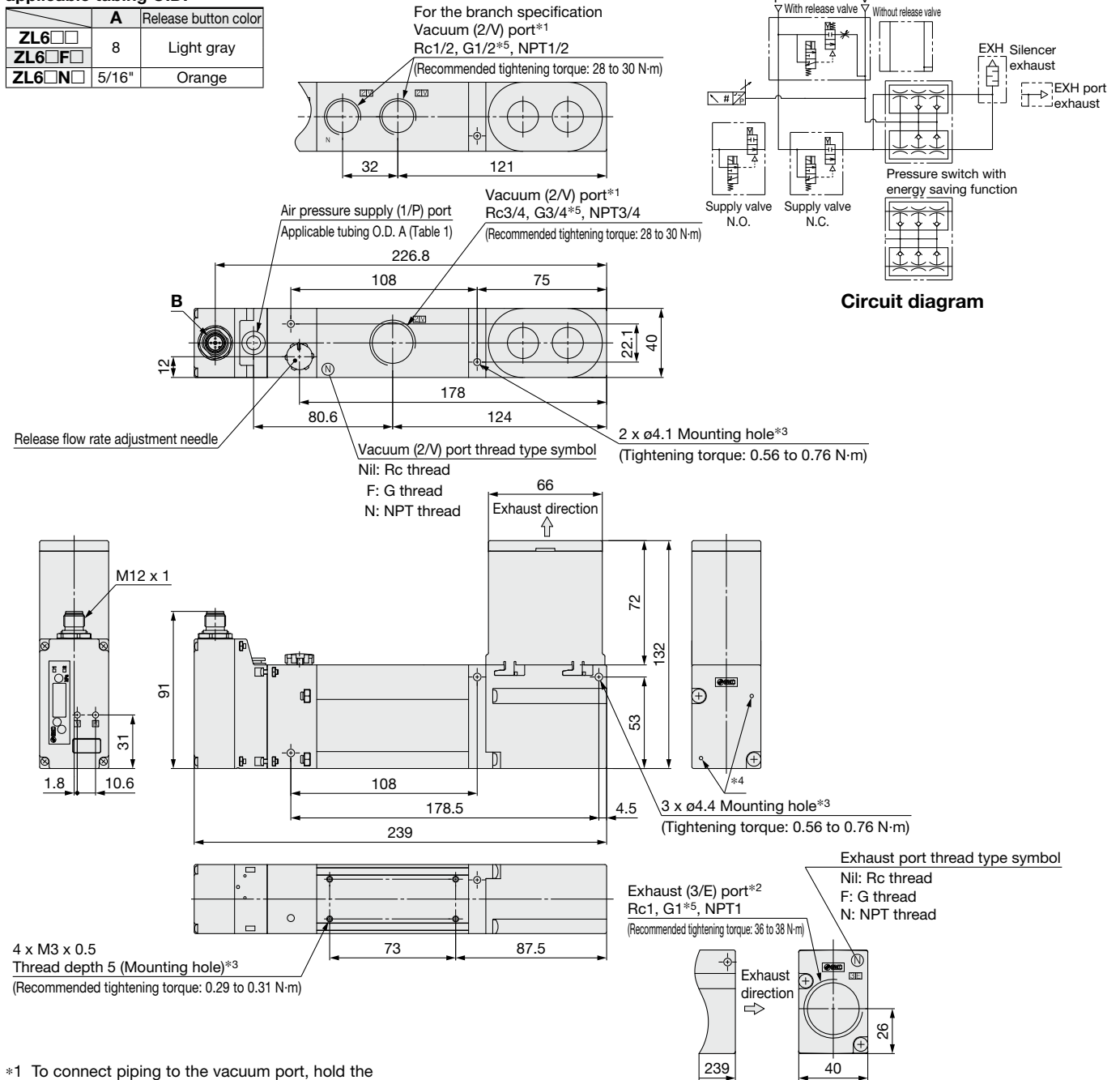

Circuit diagram

- *1 To connect piping to the vacuum port, hold the aluminum alloy body, then connect the piping.
- *2 Hold the exhaust block when connecting piping to the exhaust port. It is recommended that piping with an inner diameter of 21.7 or more be used.
- *3 Tighten to the recommended torque to mount the body. Tightening with excessive force may damage the product.
- *4 These holes are required for the forming of the product. They are not exhaust ports.
- *5 The thread ridge shape is in compliance with G thread standard ISO 228-1, but the other shapes are not in compliance with ISO 16030 or ISO 1179. Use a male thread with a length of 10.5 or less for the vacuum port and 11.5 or less for the exhaust port for connection.

Communication cable

For the vacuum pressure switch/
pressure switch for vacuum with energy saving function

Straight connector type Angled connector type

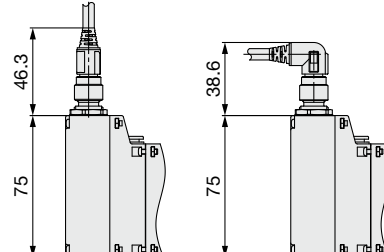

Port exhaust

For the IO-Link
compatible vacuum pressure switch

Straight connector type Angled connector type

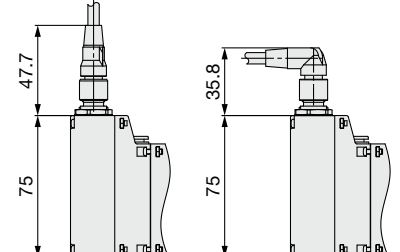

ZL3/ZL6 Series Accessories

Communication Cable

For IO-Link

Connection examples

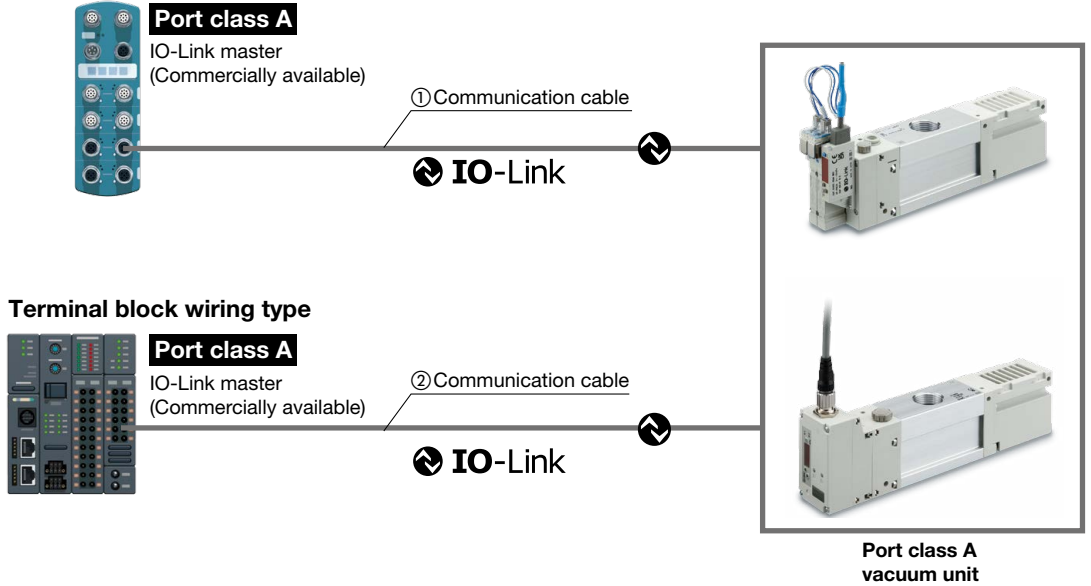

① Communication cable

EX9-AC 005 -SSPS (With connector on both sides (Socket/Plug))

● Cable length (L)

005	500 mm
010	1000 mm
020	2000 mm
030	3000 mm
050	5000 mm
100	10000 mm

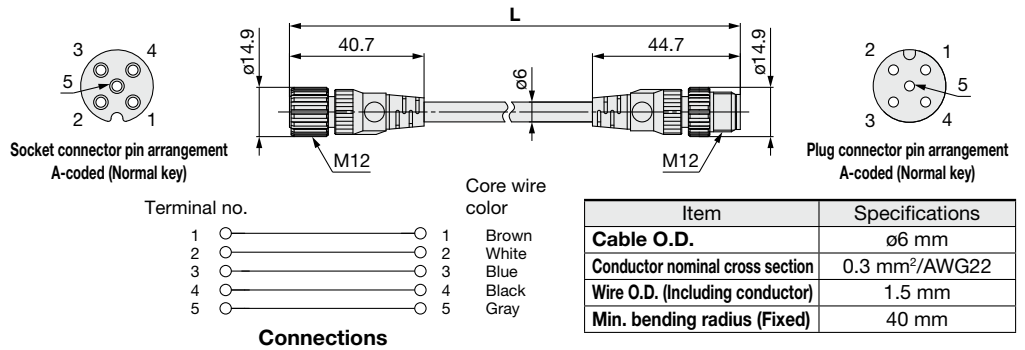

EX9-AC 005 -SAPA (With connector on both sides (Socket/Plug))

● Cable length (L)

005	500 mm
010	1000 mm
020	2000 mm
030	3000 mm
050	5000 mm
100	10000 mm

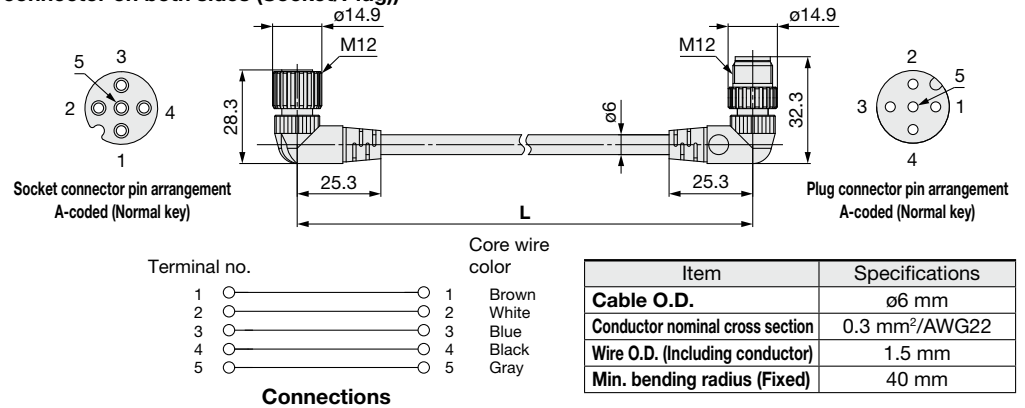

ZL3/ZL6 Series

Communication/Power Supply Cable

For IO-Link

② Communication cable

EX500-AP 050 - S

Cable length (L)

010	1000 mm
050	5000 mm

Connector specification

S	Straight
A	Angled

Straight connector type

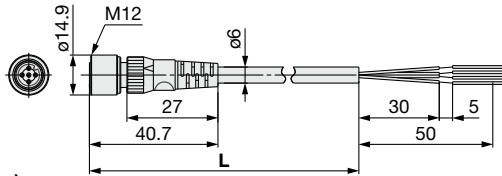
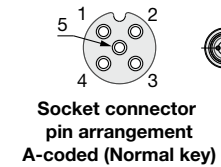

Item	Specifications
Cable O.D.	ø6 mm
Conductor nominal cross section	0.3 mm ² /AWG22
Wire O.D. (Including insulator)	1.5 mm
Min. bending radius (Fixed)	40 mm

Angled connector type

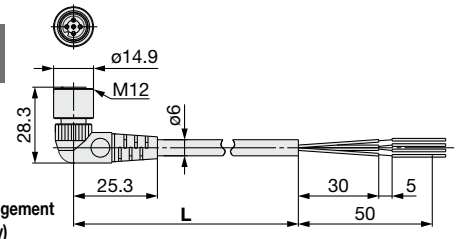
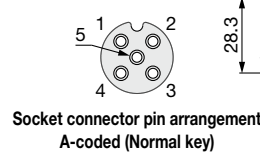

Item	Specifications
Cable O.D.	ø6 mm
Conductor nominal cross section	0.3 mm ² /AWG22
Wire O.D. (Including insulator)	1.5 mm
Min. bending radius (Fixed)	40 mm

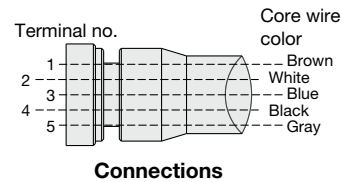

For the pressure switch for vacuum with energy saving function

③ Power supply cable (8 pins/5 cores)

ZL3-LW9-1-□ -A

Lead wire length

3	300 mm
5	500 mm
10	1000 mm
20	2000 mm
30	3000 mm

Straight connector type

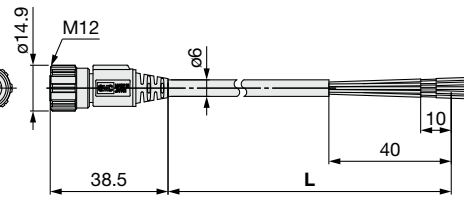
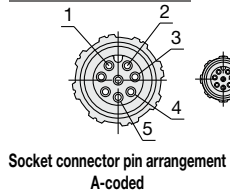

Item	Specifications
Cable O.D.	ø6 mm
Conductor nominal cross section	0.3 mm ² /AWG23
Wire O.D. (Including insulator)	1.4 mm
Min. bending radius (Fixed)	46 mm

ZL3-LW9-2-□ -A

Lead wire length

3	300 mm
5	500 mm
10	1000 mm
20	2000 mm
30	3000 mm

Angled connector type

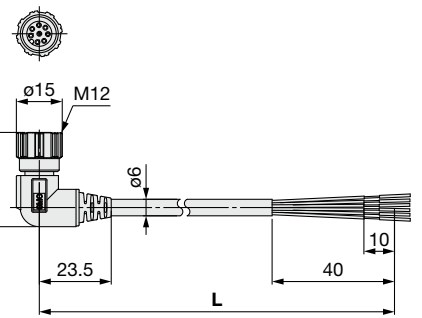
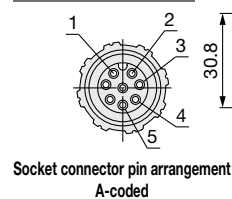

Item	Specifications
Cable O.D.	ø6 mm
Conductor nominal cross section	0.3 mm ² /AWG23
Wire O.D. (Including insulator)	1.4 mm
Min. bending radius (Fixed)	46 mm

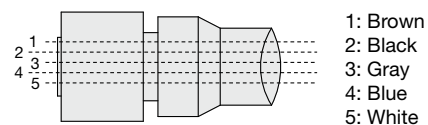

Power Supply Cable

For the vacuum pressure switch

④ Power supply cable (8 pins/6 cores)

ZL3-LW10-1-□-A

• Lead wire length

3	300 mm
5	500 mm
10	1000 mm
20	2000 mm
30	3000 mm

Straight connector type

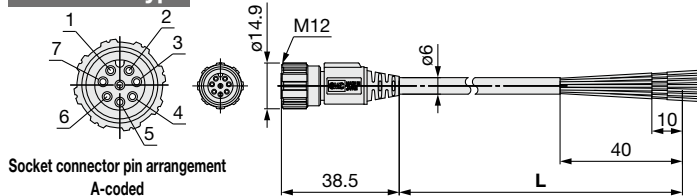

Item	Specifications
Cable O.D.	ø6 mm
Conductor nominal cross section	0.3 mm ² /AWG23
Wire O.D. (Including insulator)	1.4 mm
Min. bending radius (Fixed)	46 mm

ZL3-LW10-2-□-A

• Lead wire length

3	300 mm
5	500 mm
10	1000 mm
20	2000 mm
30	3000 mm

Angled connector type

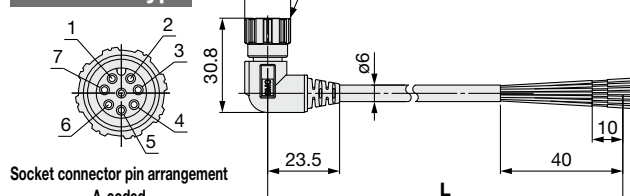

Item	Specifications
Cable O.D.	ø6 mm
Conductor nominal cross section	0.3 mm ² /AWG23
Wire O.D. (Including insulator)	1.4 mm
Min. bending radius (Fixed)	46 mm

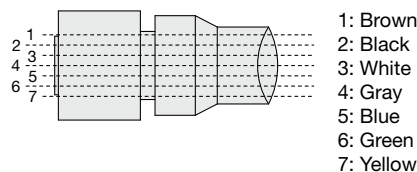

Vacuum pressure switch

NPN

M12, 8 pins, Plug

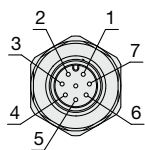

Terminal no.	Description
1	DC (+)
2	OUT1
3	OUT2
4	FUNC
5	DC (-)
6	Supply valve (-)
7	Release valve (-)

Pressure switch for vacuum with energy saving function

NPN

M12, 8 pins, Plug

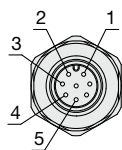

Terminal no.	Description
1	DC (+)
2	OUT1
3	FUNC
4	DC (-)
5	Release valve (-)

IO-Link compatible vacuum pressure switch

M12, 4 pins, Plug

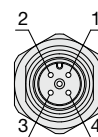

Terminal no.	Description
1	L+
2	-
3	L-
4	C/Q

PNP

M12, 8 pins, Plug

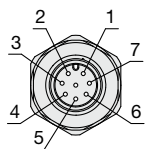

Terminal no.	Description
1	DC (+)
2	OUT1
3	OUT2
4	FUNC
5	DC (-)
6	Supply valve (+)
7	Release valve (+)

PNP

M12, 8 pins, Plug

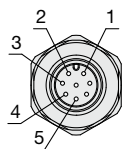



Terminal no.	Description
1	DC(+)
2	OUT1
3	FUNC
4	DC(-)
5	Release valve (+)

Safety Instructions

These safety instructions are intended to prevent hazardous situations and/or equipment damage. These instructions indicate the level of potential hazard with the labels of “**Caution**,” “**Warning**” or “**Danger**.” They are all important notes for safety and must be followed in addition to International Standards (ISO/IEC)*1), and other safety regulations.

 **Danger :** **Danger** indicates a hazard with a high level of risk which, if not avoided, will result in death or serious injury.

 **Warning:** **Warning** indicates a hazard with a medium level of risk which, if not avoided, could result in death or serious injury.

 **Caution:** **Caution** indicates a hazard with a low level of risk which, if not avoided, could result in minor or moderate injury.

*1) ISO 4414: Pneumatic fluid power - General rules and safety requirements for systems and their components
ISO 4413: Hydraulic fluid power - General rules and safety requirements for systems and their components
IEC 60204-1: Safety of machinery - Electrical equipment of machines - Part 1: General requirements
ISO 10218-1: Robots and robotic devices - Safety requirements for industrial robots - Part 1: Robots etc.

Warning

1. The compatibility of the product is the responsibility of the person who designs the equipment or decides its specifications.

Since the product specified here is used under various operating conditions, its compatibility with specific equipment must be decided by the person who designs the equipment or decides its specifications based on necessary analysis and test results. The expected performance and safety assurance of the equipment will be the responsibility of the person who has determined its compatibility with the product. This person should also continuously review all specifications of the product referring to its latest catalog information, with a view to giving due consideration to any possibility of equipment failure when configuring the equipment.

2. Only personnel with appropriate training should operate machinery and equipment.

The product specified here may become unsafe if handled incorrectly. The assembly, operation and maintenance of machines or equipment including our products must be performed by an operator who is appropriately trained and experienced.

3. Do not service or attempt to remove product and machinery/equipment until safety is confirmed.

1. The inspection and maintenance of machinery/equipment should only be performed after measures to prevent falling or runaway of the driven objects have been confirmed.
2. When the product is to be removed, confirm that the safety measures as mentioned above are implemented and the power from any appropriate source is cut, and read and understand the specific product precautions of all relevant products carefully.
3. Before machinery/equipment is restarted, take measures to prevent unexpected operation and malfunction.

4. SMC products cannot be used beyond their specifications. They are not developed, designed, and manufactured to be used under the following conditions or environments. Use under such conditions or environments is not allowed.

1. Conditions and environments outside of the given specifications, or use outdoors or in a place exposed to direct sunlight.
2. Use for nuclear power, railways, aviation, space equipment, ships, vehicles, military application, equipment affecting human life, body, and property, combustion equipment, entertainment equipment, emergency shut-off circuits, press clutches, brake circuits, safety equipment, etc., and use for applications that do not conform to standard specifications such as catalogs and operation manuals.
3. Use for interlock circuits, except for use with double interlock such as installing a mechanical protection function in case of failure. Please periodically inspect the product to confirm that the product is operating properly.

Caution

SMC develops, designs, and manufactures products to be used for automatic control equipment, and provides them for peaceful use in manufacturing industries.

Use in non-manufacturing industries is not allowed.

Products SMC manufactures and sells cannot be used for the purpose of transactions or certification specified in the Measurement Act of each country. The new Measurement Act prohibits use of any unit other than SI units in Japan.

Limited warranty and Disclaimer/ Compliance Requirements

The product used is subject to the following “Limited warranty and Disclaimer” and “Compliance Requirements”.

Read and accept them before using the product.

Limited warranty and Disclaimer

1. The warranty period of the product is 1 year in service or 1.5 years after the product is delivered, whichever is first.*2)
Also, the product may have specified durability, running distance or replacement parts. Please consult your nearest sales branch.
2. For any failure or damage reported within the warranty period which is clearly our responsibility, a replacement product or necessary parts will be provided.
This limited warranty applies only to our product independently, and not to any other damage incurred due to the failure of the product.
3. Prior to using SMC products, please read and understand the warranty terms and disclaimers noted in the specified catalog for the particular products.

*2) **Suction cups (Vacuum pads) are excluded from this 1 year warranty.**

A suction cup (vacuum pad) is a consumable part, so it is warranted for a year after it is delivered.

Also, even within the warranty period, the wear of a product due to the use of the suction cup (vacuum pad) or failure due to the deterioration of rubber material are not allowed by the limited warranty.

Compliance Requirements

1. The use of SMC products with production equipment for the manufacture of weapons of mass destruction (WMD) or any other weapon is strictly prohibited.
2. The exports of SMC products or technology from one country to another are governed by the relevant security laws and regulations of the countries involved in the transaction. Prior to the shipment of a SMC product to another country, assure that all local rules governing that export are known and followed.

Revision History

Edition B * The ZL3 and ZL6 have been added.

* Errors in text have been corrected.

* The number of pages has been increased from 20 to 36.

Edition C * An N.O. specification has been added to the pressure switch for vacuum with energy saving function.

* An IO-Link compatible vacuum pressure switch has been added.

* The number of pages has been increased from 36 to 44.

Edition D * The ZL1 series built-in vacuum pressure switch has been changed to the ZSE20A.

* An IO-Link compatible vacuum pressure switch has been added.

Edition E * An M12 connector (IP65 specification) has been added to the ZL3/ZL6 series.

* The number of pages has been increased from 44 to 48.

 **Safety Instructions** Be sure to read the “Handling Precautions for SMC Products” (M-E03-3) and “Operation Manual” before use.