

Vacuum Pad/ Bowl Shape with Non-slip Feature

Bowl Shape

ø32, ø40, ø50, ø63, ø80, ø100

Bowl Bellows Shape

ø50, ø63, ø80

RoHS

Longer life (More than twice the life of urethane pads)

Pad material: **FS61** (Fluoro-based rubber) with excellent abrasion resistance
Reduced number of pad replacements

Non-slip special ribs

Diagonal ribs are radially arranged to secure the gripping force in all directions.

- Prevents workpiece slippage
- Secure adsorbing and transferring are possible.

Bowl shape with excellent flexibility

Curved workpieces can also be adsorbed.

Horizontal holding force: 387 N (Pad diameter ø100)*1

Suitable for high-temperature workpieces (200°C)*1

*1 For details, refer to the specifications on pages 4 and 11.

Suitable for workpieces with oil film

As oil is ejected to the grooves between special ribs, the lateral slipping of workpiece can be suppressed even on a steel plate with oil film.

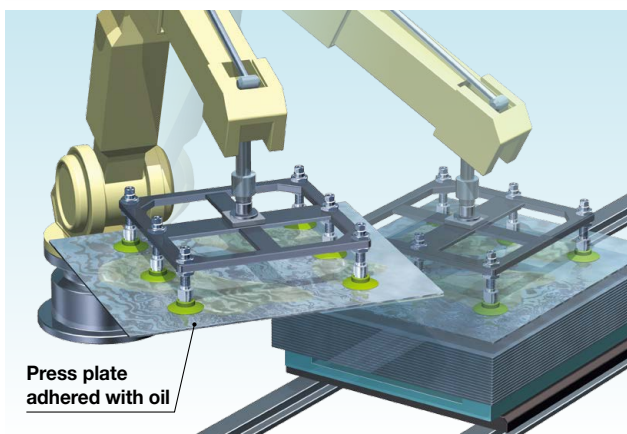
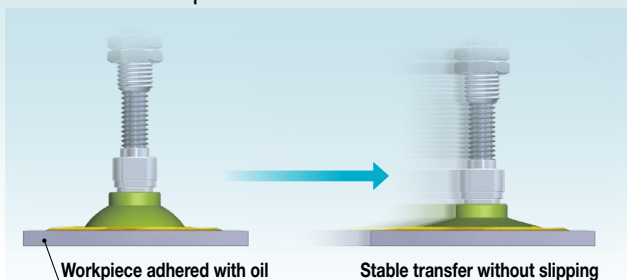

New Bowl bellows shape

The bowl shape can handle curved workpieces.

The pad follows the workpiece shape, making stable adsorption possible.

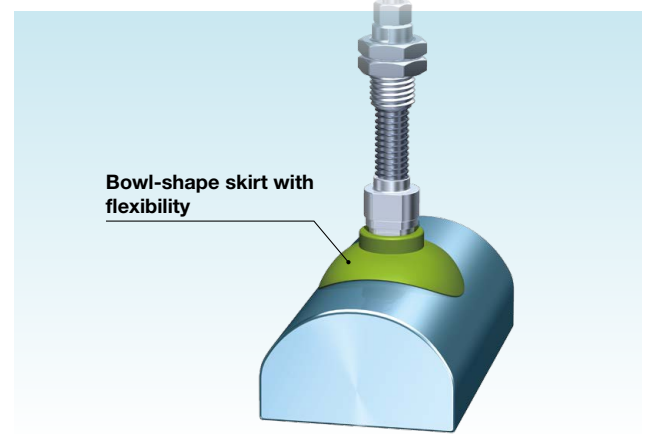

ZP3M Series

SMC

CAT.ES100-147B

Vacuum Pad/Bowl Shape with Non-slip Feature *ZP3M Series*

Mesh filter (Option)

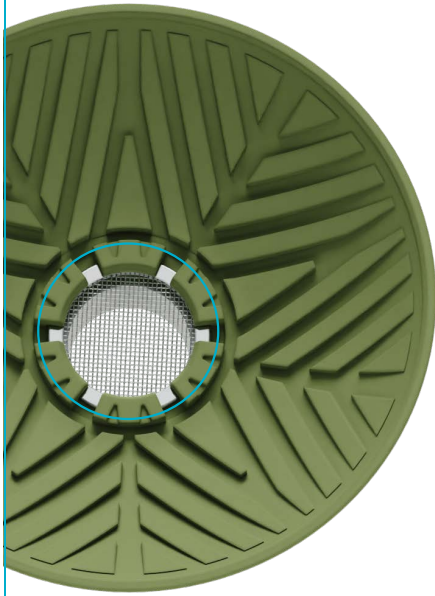

- Reduced suction of foreign matter into the vacuum pump and ejector
- Detachable
- Opening: 250 μm

Installation from below is possible.



Insert-molded pad to prevent the pad from falling out of the adapter

Bowl bellows shape

Discharge time maximum reduced by **40%** during adsorption horizontal transfer

Transfer conditions	Pad diameter: ø50, Workpiece mass: 1.3 kg, Supply pressure: -85 kPa, Acceleration/Deceleration: 5 [G]
---------------------	---

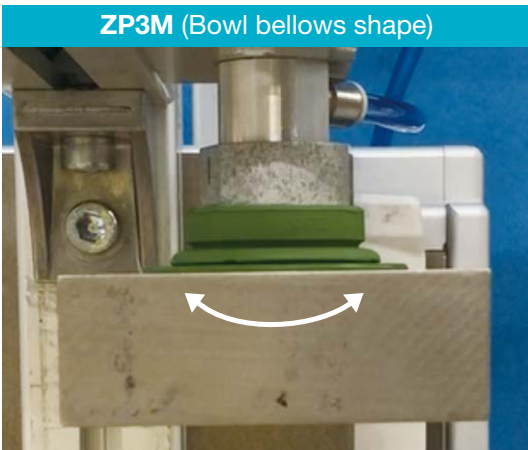

Deflection Small Discharge time **0.18 s**



Deflection Large Discharge time **0.30 s**

Relationship between the amplitude and time

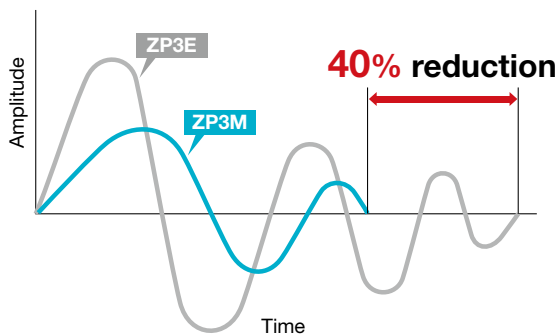

Bowl Shape Variations

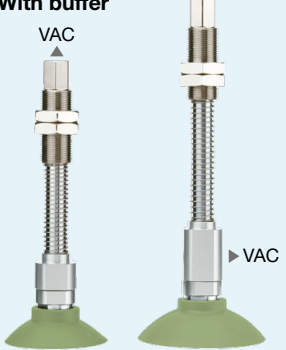
Type	Mounting	Vacuum inlet direction	Connection		Vacuum inlet		Page	
			Type	Size		Size		
				Pad diameter: $\varnothing 32$ to $\varnothing 50$	Pad diameter: $\varnothing 63$ to $\varnothing 100$	Pad diameter: $\varnothing 32$ to $\varnothing 50$		Pad diameter: $\varnothing 63$ to $\varnothing 100$
 <p>With adapter</p>	Direct mounting	Vertical	Male thread	M10 x 1.0	M16 x 1.5	Use the connection thread.	p. 4	
			Female thread	G1/4				
				M14 x 1.0				
Square adapter	$\square 31.8$							
 <p>With buffer</p>	Plate mounting	Vertical	Male thread	M18 x 1.5	M22 x 1.5	M5 x 0.8	Rc1/8	
		Lateral						

Bowl Bellows Shape Variations

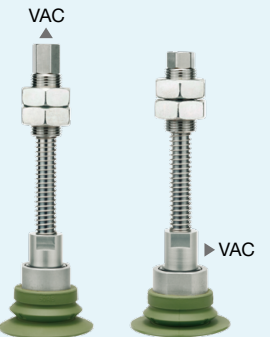
Type	Mounting	Vacuum inlet direction	Connection		Vacuum inlet		Page	
			Type	Size		Size		
				Pad diameter: $\varnothing 50$	Pad diameter: $\varnothing 63, \varnothing 80$	Pad diameter: $\varnothing 50$		Pad diameter: $\varnothing 63, \varnothing 80$
 <p>With adapter</p>	Direct mounting	Vertical	Male thread	M10 x 1.0	M16 x 1.5	Use the connection thread.	p. 11	
			Female thread	G1/4				
				G3/8				
Square adapter	$\square 31.8$							
 <p>With buffer</p>	Plate mounting	Vertical	Male thread	M18 x 1.5	M22 x 1.5	M5 x 0.8	Rc1/8	
		Lateral						

CONTENTS

Vacuum Pad/ Bowl Shape with Non-slip Feature *ZP3M Series*

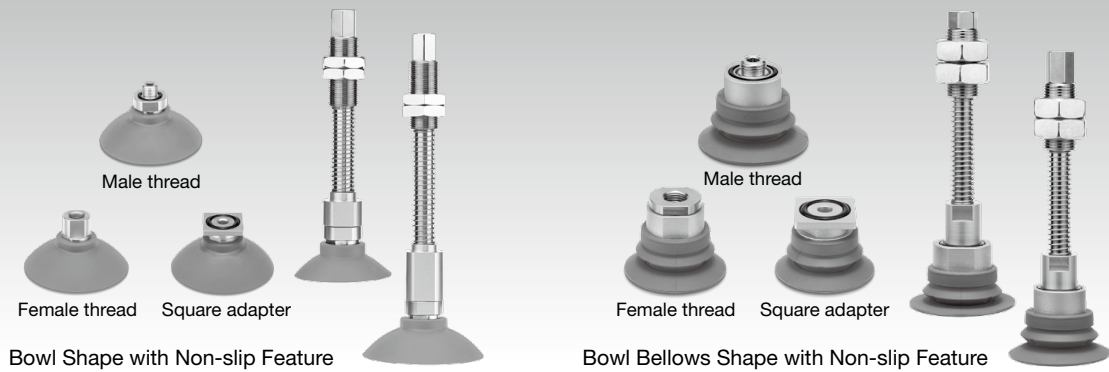

• Bowl Shape with Non-slip Feature

How to Order	p. 4
Specifications	p. 4
Dimensions/Models	p. 5
Construction	p. 9
Mounting Bracket Assembly	p. 10

• Bowl Bellows Shape with Non-slip Feature

How to Order	p. 11
Specifications	p. 11
Dimensions/Models	p. 12
Construction	p. 16
Mounting Bracket Assembly	p. 17

Specific Product Precautions	p. 18
------------------------------------	-------

Vacuum Pad/ Bowl Shape with Non-slip Feature ZP3M Series

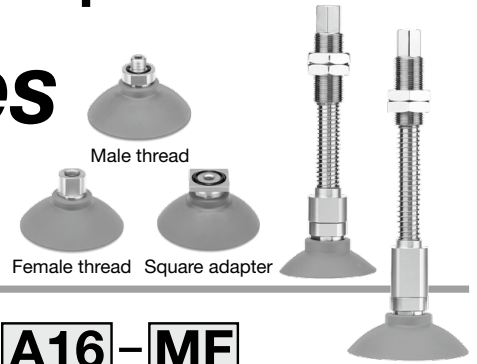

How to Order

With adapter

ZP3M - T 63 R FS - A16 - MF

With buffer

ZP3M - T 63 R FS JB 30 - MF

1 Bowl shape 2 Pad diameter 3 Material 4 With buffer 5 Connection thread and type 6 Mesh filter

1 Vacuum inlet direction

T	Vertical
Y	Lateral

4 Buffer stroke

Stroke [mm]	Pad size	
	All sizes	
10	●	
30	●	
50	●	

6 Mesh filter

Nil	None
MF	With mesh filter

Mesh filter unit

Part no.	Pad diameter	
	ø32 to ø50	ø63 to ø100
ZPMF-60-D13	●	—
ZPMF-60-D18	—	●

2 Pad diameter

32	ø32
40	ø40
50	ø50
63	ø63
80	ø80
100	ø100

3 Material

Symbol	Material	Color
FS	FS61 (Fluoro-based rubber)	Green

5 Connection thread and type

Mounting	Type	Symbol	Size	Pad diameter	
				ø32 to ø50	ø63 to ø100
Direct mounting	Male thread	A10	M10 x 1.0	●	—
		A16	M16 x 1.5	—	●
		AG02	G1/4	●	●
	Female thread	B14	M14 x 1.0	●	●
		BG02	G1/4	●	●
		BG03	G3/8	●	●
	Square adapter	S32	□31.8	●	●

* The adapter and pad are adhered to each other and cannot be disassembled.

Specifications

Pad Material

Material	FS61 (Fluoro-based rubber)
Color of rubber	Green
Rubber hardness (Shore A: ±5°)	60
Operating temperature range*1	0°C to 200°C
Ambient temperature	0°C to 150°C

*1 Surface temperature of the workpiece to be adsorbed

Adapter Specifications

Connection	Male thread		Female thread	Square adapter
Pad diameter	ø32 to ø50	ø63 to ø100	ø32 to ø100	ø32 to ø100
Size	M10 x 1.0 G1/4	M16 x 1.5 G1/4	M14 x 1.0 G1/4 G3/8	□31.8
Vacuum inlet	Use the connection thread and type.			

Buffer Specifications

Non-rotating specification	ø32 to ø50			ø63 to ø100				
	JB: Rotating, With bushing			JB: Rotating, With bushing				
Stroke [mm]	10	30	50	10	30	50		
Connection thread	M18 x 1.5			M22 x 1.5				
Spring reactive force	At 0 stroke			10.0				
	At full stroke			6.5	8.5	10.5	11.5	13.5

Pad Specifications

Part no.	Horizontal holding force [N]*1		Minimum curvature radius for adsorption [mm]*2
	Without oil	With oil	
ZP3M-T32RFS	47	21	14
ZP3M-T40RFS	81	53	15
ZP3M-T50RFS	111	74	20
ZP3M-T63RFS	170	108	27.5
ZP3M-T80RFS	231	178	36
ZP3M-T100RFS	387	224	46

*1 These are actual measurement values when flat workpieces were adsorbed at a setting vacuum pressure of -60 kPa; however, they are not guaranteed values. (According to SMC's tests)

The values vary depending on the conditions (shape, surface roughness, oil type, oil amount, and other conditions) of the workpiece.

*2 These are actual measurement values when cylindrical workpieces were adsorbed at a setting vacuum pressure of -85 kPa; however, they are not guaranteed values. (According to SMC's tests)

Mesh Filter Specifications

Mesh filter	60
Opening	250 μm

Buffer assembly part no. p. 10

ZP3M Series

Dimensions/Models

With adapter Direct mounting type (Male thread)

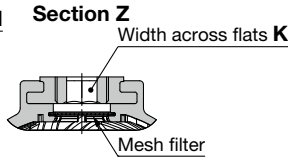
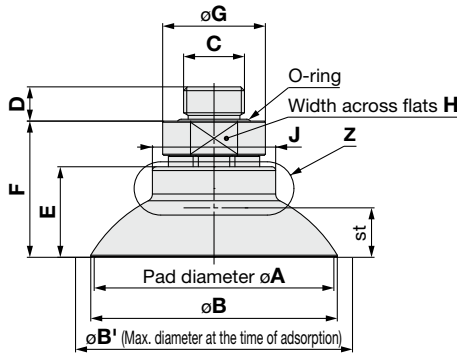

ZP3M - T **63** R **FS** - **A16** - **MF**

① ② ③ ④



		Pad diameter [mm]	
		ø32 to ø50	ø63 to ø100
A10	M10 x 1.0	○	-
A16	M16 x 1.5	-	○
AG02	G1/4	○	○

Model						A	B	B ¹ *2	C	D	E	F	G	H	J	K	st*2	Min. opening hole size of the adapter	Weight [g]
Vacuum inlet direction	① Pad diameter	Form	② Material *1	③ Connection thread	④ Mesh filter														
ZP3M	T	R	FS	Nil	MF	32	33.2	38.3	M10 x 1.0	7	14.3	23.8	20	17	20.4	5	6	ø5	16.1
									G1/4	6.5		24.1	25	22					24.5
						40	41.3	47.8	M10 x 1.0	7	17.8	27.3	20	17	21	5	8.4	ø5	17.3
									G1/4	6.5		27.6	25	22					25.7
						50	51.6	58.6	M10 x 1.0	7	19.4	28.9	20	17	21.4	5	10.4	ø5	21.1
									G1/4	6.5		29.2	25	22					29.5
	63	64.8	73.3	M16 x 1.5	9	24.1	36.1	27	24	32.4	8	12	ø8	47.1					
				G1/4	6.5		35.6							ø6	46.7				
	80	81.8	92.2	M16 x 1.5	9	27.1	39.1	27	24	33	8	14.4	ø8		61.3				
				G1/4	6.5		38.6							ø6	60.9				
	100	102.2	113.4	M16 x 1.5	9	33.9	45.9	27	24	34.4	8	20.1	ø8		96.7				
				G1/4	6.5		45.4							ø6	100.4				

*1 FS: FS61 (Fluoro-based rubber)

*2 B': Maximum pad diameter at the time of adsorption, st: The stroke is a guide value at the setting vacuum pressure of -90 kPa.

With adapter Direct mounting type (Female thread)

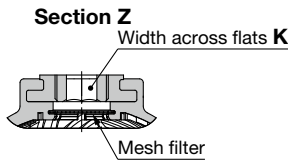
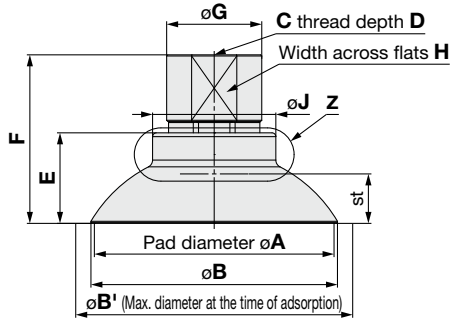

ZP3M - T **63** R **FS** - **B14** - **MF**

① ② ③ ④



		Pad diameter [mm]	
		ø32 to ø100	
B14	M14 x 1.0	○	
BG02	G1/4	○	
BG03	G3/8	○	

Model						A	B	B ¹ *2	C	D	E	F	G	H	J	K	st*2	Min. opening hole size of the adapter	Weight [g]
Vacuum inlet direction	① Pad diameter	Form	② Material *1	③ Connection thread	④ Mesh filter														
ZP3M	T	R	FS	Nil	MF	32	33.2	38.3	M14 x 1.0	8	14.3	31.6	23	19	20.4	5	6	ø5	20.9
									G1/4	11		33.6	20	17					19.1
									G3/8	11.4		34.1	26	22					26.3
						40	41.3	47.8	M14 x 1.0	8	17.8	35.1	23	19	21	5	8.4	ø5	22.1
									G1/4	11		37.1	20	17					20.3
									G3/8	11.4		37.6	26	22					27.5
						50	51.6	58.6	M14 x 1.0	8	19.4	36.7	23	19	21.4	5	10.4	ø5	25.9
									G1/4	11		38.7	20	17					24.1
									G3/8	11.4		39.2	26	22					31.3
						63	64.8	73.3	M14 x 1.0	8	24.1	41.6	23	19	32.4	8	12	ø8	42.2
									G1/4	11		42.6	22	19					42.5
									G3/8	11.4		44.6	25	22					46.4
	80	81.8	92.2	M14 x 1.0	8	27.1	44.6	23	19	33	8	14.4	ø8	56.4					
				G1/4	11		45.6	22	19					56.7					
				G3/8	11.4		47.6	25	22					60.5					
	100	102.2	113.4	M14 x 1.0	8	33.9	51.4	23	19	34.4	8	20.1	ø8	92.3					
				G1/4	11		52.4	22	19					92.6					
				G3/8	11.4		54.4	25	22					96.5					

*1 FS: FS61 (Fluoro-based rubber)

*2 B': Maximum pad diameter at the time of adsorption, st: The stroke is a guide value at the setting vacuum pressure of -90 kPa.

Dimensions/Models

With adapter Direct mounting type (Square adapter)

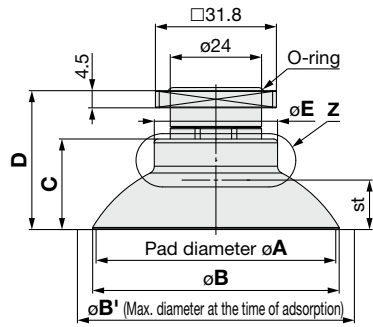

ZP3M - T **①** **②** R **③** FS - S32 - MF

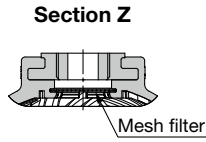

	Model						A	B	B ^{*2}	C	D	E	st ^{*2}	Min. opening hole size of the adapter	Weight [g]
	Vacuum inlet direction	① Pad diameter	Form	② Material *1	Connection thread	③ Mesh filter									
ZP3M	T	32	R	FS	S32	Nil MF	32	33.2	38.3	14.3	26.3	20.4	6	φ5	26.1
		40					41.3	47.8	17.8	29.8	21	8.4	φ5	27.3	
		50					51.6	58.6	19.4	31.4	21.4	10.4	φ5	31.1	
		63					64.8	73.3	24.1	36.8	32.4	12	φ8	48.7	
		80					81.8	92.2	27.1	39.8	33	14.4	φ8	62.8	
		100					102.2	113.4	33.9	46.6	34.4	20.1	φ8	97.4	

*1 FS: FS61 (Fluoro-based rubber)

*2 B': Maximum pad diameter at the time of adsorption, st: The stroke is a guide value at the setting vacuum pressure of -90 kPa.

Square adapter mounting groove dimensions (Recommended)

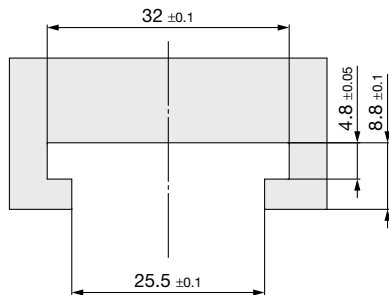

* For details on how to use the square adapter, refer to "Mounting" on page 18.

ZP3M Series

Dimensions/Models

With buffer Plate mounting type (Vacuum inlet direction: Vertical)

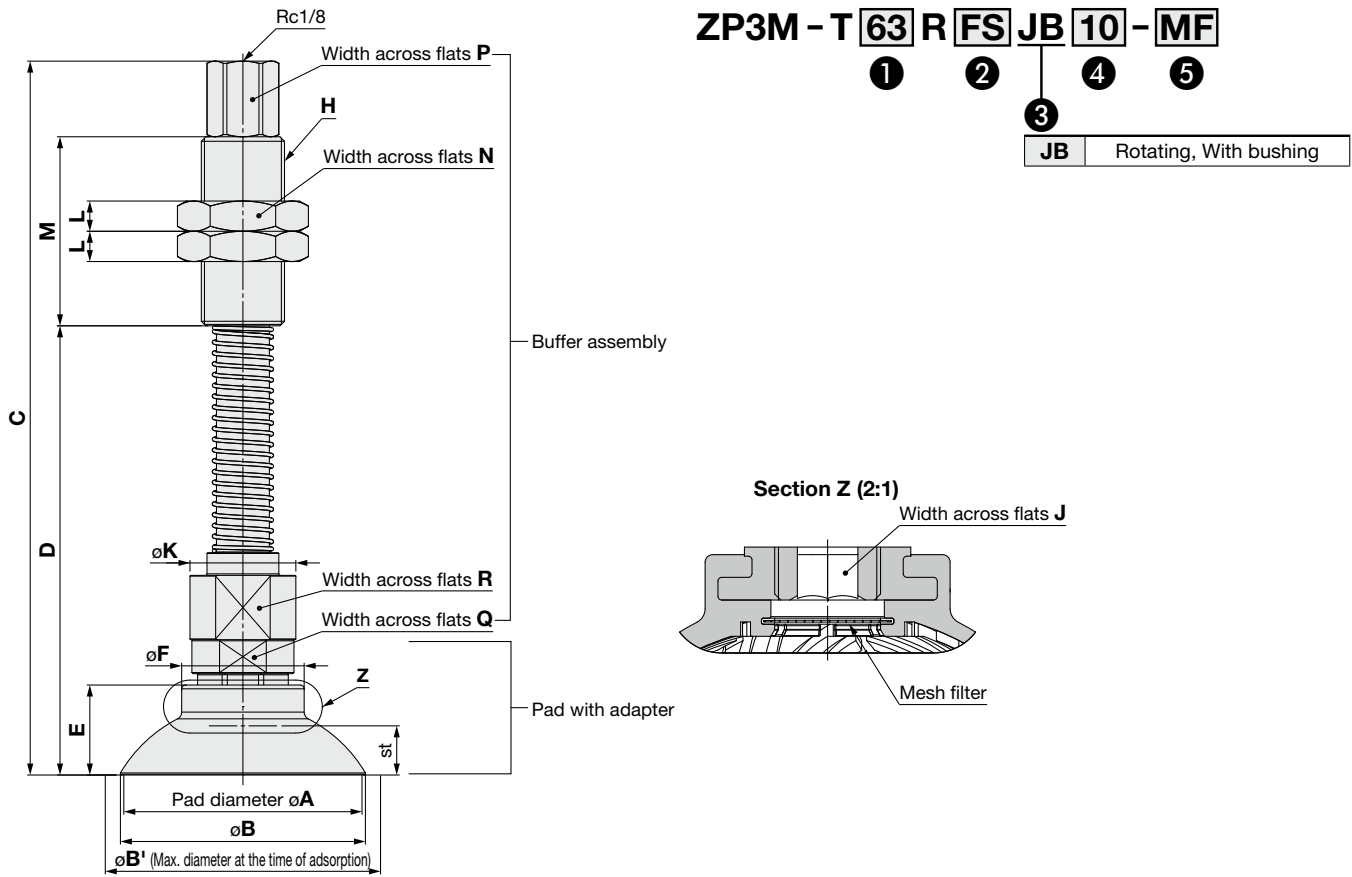

		Model						A	B	B ^{*2}	C	D	E	F	H	J	K	L	M	N	P	Q	R	st ^{*2}	Min. opening hole size of the adapter	Weight [g]	
Vacuum inlet direction	1 Pad diameter	Form	Material ^{*1}	3 Buffer spec.	4 Buffer stroke	5 Mesh filter																					
ZP3M	T	R	FS	JB	10	Nil MF	32	33.2	38.3	123.3	71.3	14.3	20.4												6	ø3	205
					30					148.3	96.3																219.5
					50					168.3	116.3																231
					10					126.8	74.8																206.2
					30					151.8	99.8																220.7
					50					171.8	119.8																232.2
	50	10	128.4	76.4	210																						
		30	153.4	101.4	224.5																						
		50	173.4	121.4	236																						
		10	164.1	94.1	210																						
		30	189.1	119.1	236																						
		50	209.1	139.1	236																						
	63	10	167.1	97.1	355																						
		30	192.1	122.1	383.8																						
		50	212.1	142.1	406.7																						
		10	173.9	103.9	369.2																						
30		198.9	128.9	397.9																							
50		218.9	148.9	420.9																							
80	10	173.9	103.9	404.6																							
	30	198.9	128.9	433.4																							
	50	218.9	148.9	456.3																							
	10	173.9	103.9	404.6																							
	30	198.9	128.9	433.4																							
	50	218.9	148.9	456.3																							
100	10	173.9	103.9	404.6																							
	30	198.9	128.9	433.4																							
	50	218.9	148.9	456.3																							
	10	173.9	103.9	404.6																							
	30	198.9	128.9	433.4																							
	50	218.9	148.9	456.3																							

*1 FS: FS61 (Fluoro-based rubber)

*2 B': Maximum pad diameter at the time of adsorption, st: The stroke is a guide value at the setting vacuum pressure of -90 kPa.

Dimensions/Models

With buffer Plate mounting type (Vacuum inlet direction: Lateral)

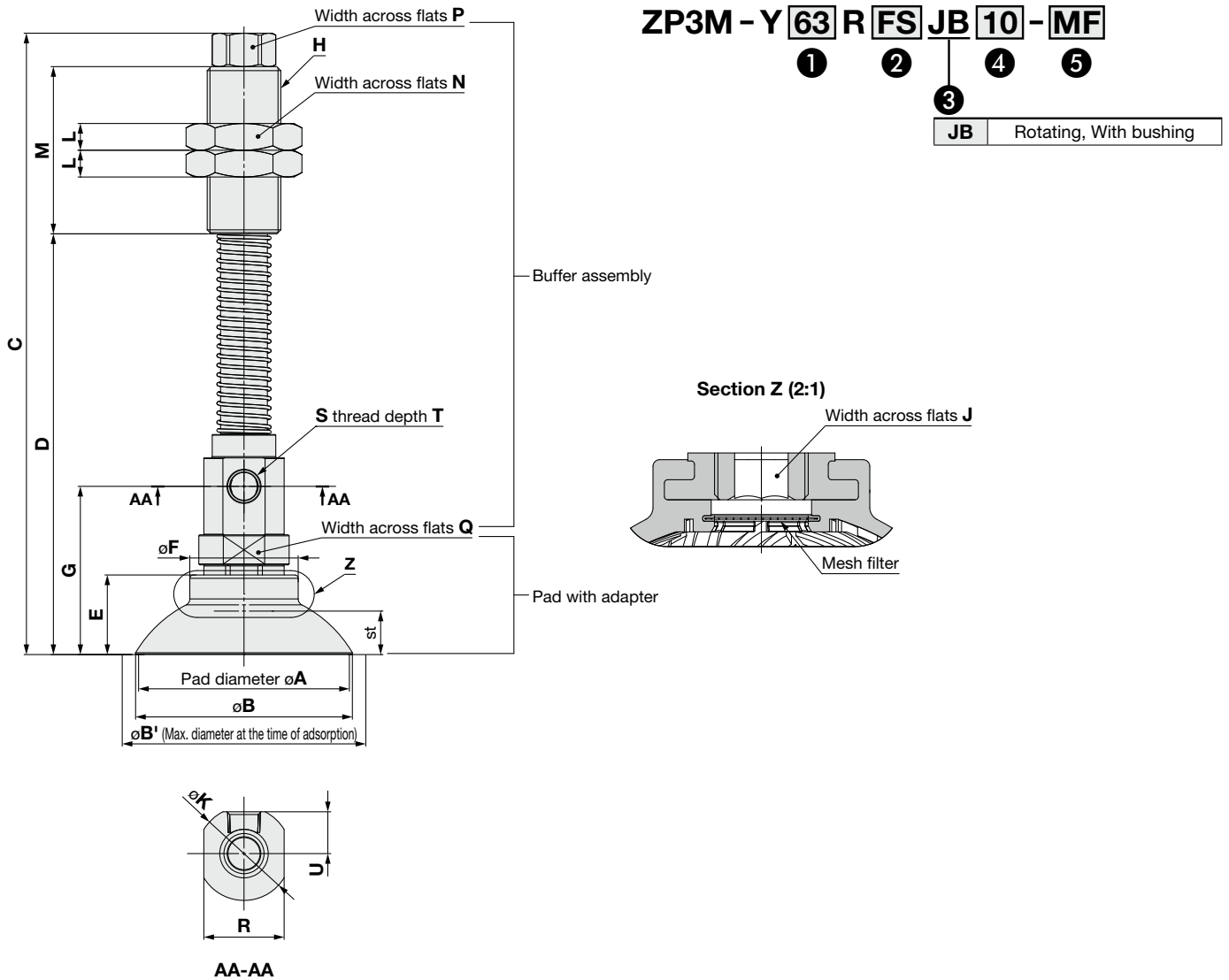

		Model					A	B	B ^{*2}	C	D	E	F	G	H	J	K	L	M	N	P	Q	R	S	T	U	st ^{*2}	Min. opening hole size of the adapter	Weight [g]	
Vacuum inlet direction	① Pad diameter	Form	② Material *1	③ Buffer spec.	④ Buffer stroke	⑤ Mesh filter																								
ZP3M	Y	R	FS	JB	10	Nil MF		32	33.2	38.3	118.3	74.3	14.3	20.4	33.7	M18 x 1.5	5	19	11	35	27	14	17	16	M5 x 0.8	5	8.5	8.4	ø5	203.2
					30						143.3	99.3																		219.1
					50						163.3	119.3																		231.6
					10						121.8	77.8																		204.4
					30						146.8	102.8																		220.3
					50						166.8	122.8																		232.8
	Y	R	FS	JB	10	Nil MF		40	41.3	47.8	123.4	79.4	17.8	21	37.2	M18 x 1.5	5	19	11	35	27	14	17	16	M5 x 0.8	5	8.5	8.4	ø5	208.2
					30						148.4	104.4																		224.1
					50						168.4	124.4																		236.6
					10						161.1	101.1																		204.4
					30						186.1	126.1																		220.3
					50						206.1	146.1																		232.8
Y	R	FS	JB	10	Nil MF		50	51.6	58.6	123.4	79.4	19.4	21.4	38.8	M18 x 1.5	5	19	11	35	27	14	17	16	M5 x 0.8	5	8.5	8.4	ø5	208.2	
				30						148.4	104.4																		224.1	
				50						168.4	124.4																		236.6	
				10						161.1	101.1																		204.4	
				30						186.1	126.1																		220.3	
				50						206.1	146.1																		232.8	
Y	R	FS	JB	10	Nil MF		63.5	64.8	73.3	161.1	101.1	24.1	32.4	50.6	M18 x 1.5	5	19	11	35	27	14	17	16	M5 x 0.8	5	8.5	8.4	ø5	355.6	
				30						186.1	126.1																		386.8	
				50						206.1	146.1																		411.7	
				10						164.1	104.1																		369.7	
				30						189.1	129.1																		400.9	
				50						209.1	149.1																		425.9	
Y	R	FS	JB	10	Nil MF		80.6	81.8	92.2	170.9	110.9	27.1	33	53.6	M22 x 1.5	8	28	8	50	30	17	24	24	Rc1/8	-	12.5	14.4	ø8	405.2	
				30						195.9	135.9																		436.4	
				50						215.9	155.9																		461.3	
				10						170.9	110.9																		405.2	
				30						195.9	135.9																		436.4	
				50						215.9	155.9																		461.3	
Y	R	FS	JB	10	Nil MF		100	102.2	113.4	170.9	110.9	33.9	34.4	60.4	M22 x 1.5	8	28	8	50	30	17	24	24	Rc1/8	-	12.5	14.4	ø8	405.2	
				30						195.9	135.9																		436.4	
				50						215.9	155.9																		461.3	
				10						170.9	110.9																		405.2	
				30						195.9	135.9																		436.4	
				50						215.9	155.9																		461.3	

*1 FS: FS61 (Fluoro-based rubber)

*2 B': Maximum pad diameter at the time of adsorption, st: The stroke is a guide value at the setting vacuum pressure of -90 kPa.

ZP3M Series

Construction

With adapter

ZP3M-T□RFS-A□ ZP3M-T□RFS-B□ ZP3M-T□RFS-S32

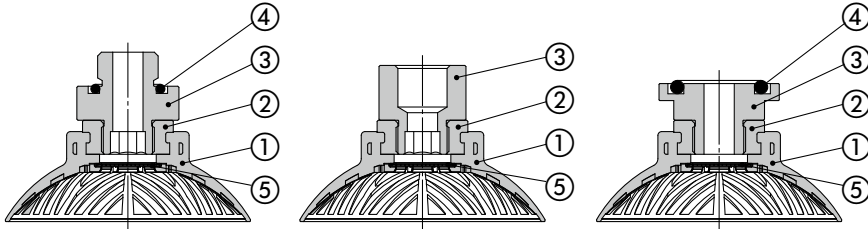

Component Parts

No.	Description	Material
1	Pad	FS61 (Fluoro-based rubber)
2	Insert adapter	Aluminum alloy
3	Adapter	Aluminum alloy (Anodized)
4	O-ring	FKM
5	Mesh filter	Stainless steel

* The parts 1, 2, and 3 are adhered to each other and cannot be disassembled.

With buffer

ZP3M-T□RFSJB□-□

ZP3M-Y□RFSJB□-□

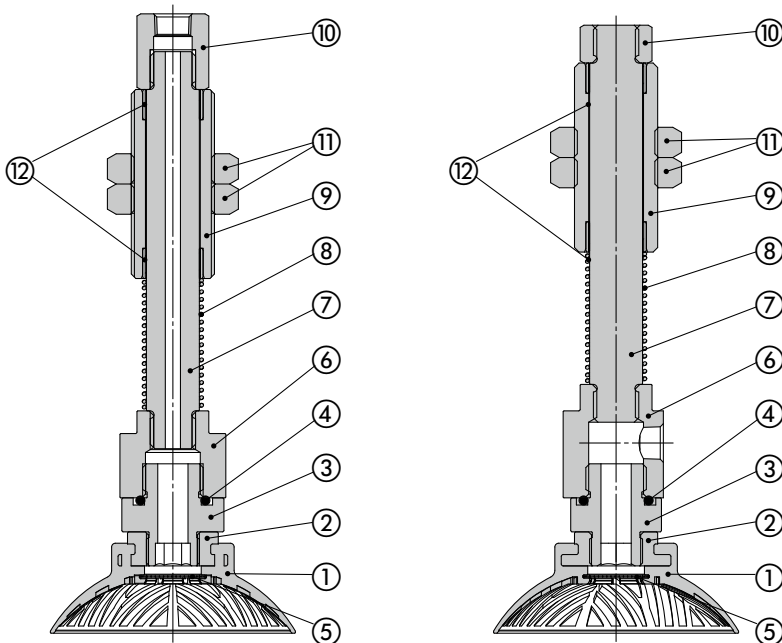

Component Parts

No.	Description	Material
1	Pad	FS61 (Fluoro-based rubber)
2	Insert adapter	Aluminum alloy
3	Adapter	Aluminum alloy (Anodized)
4	O-ring	FKM
5	Mesh filter	Stainless steel
6	Adapter	Aluminum alloy (Anodized)
7	Piston rod	Structural steel (Hard chrome plating)
8	Return spring	Stainless steel
9	Buffer body	Brass (Electroless nickel plating)
10	Buffer adapter	Brass (Electroless nickel plating)
11	Nut	Steel (Zinc chromated) M18 x 1.5
		Structural steel (Nickel plating) M22 x 1.5
12	Bushing	-

* The parts 1, 2, and 3 are adhered to each other and cannot be disassembled.

Replacement Parts: Mesh Filter Unit

Part no.	Pad diameter	
	ø32 to ø50	ø63 to ø100
ZPMF-60-D13	●	-
ZPMF-60-D18	-	●



ZP3M Series

Mounting Bracket Assembly

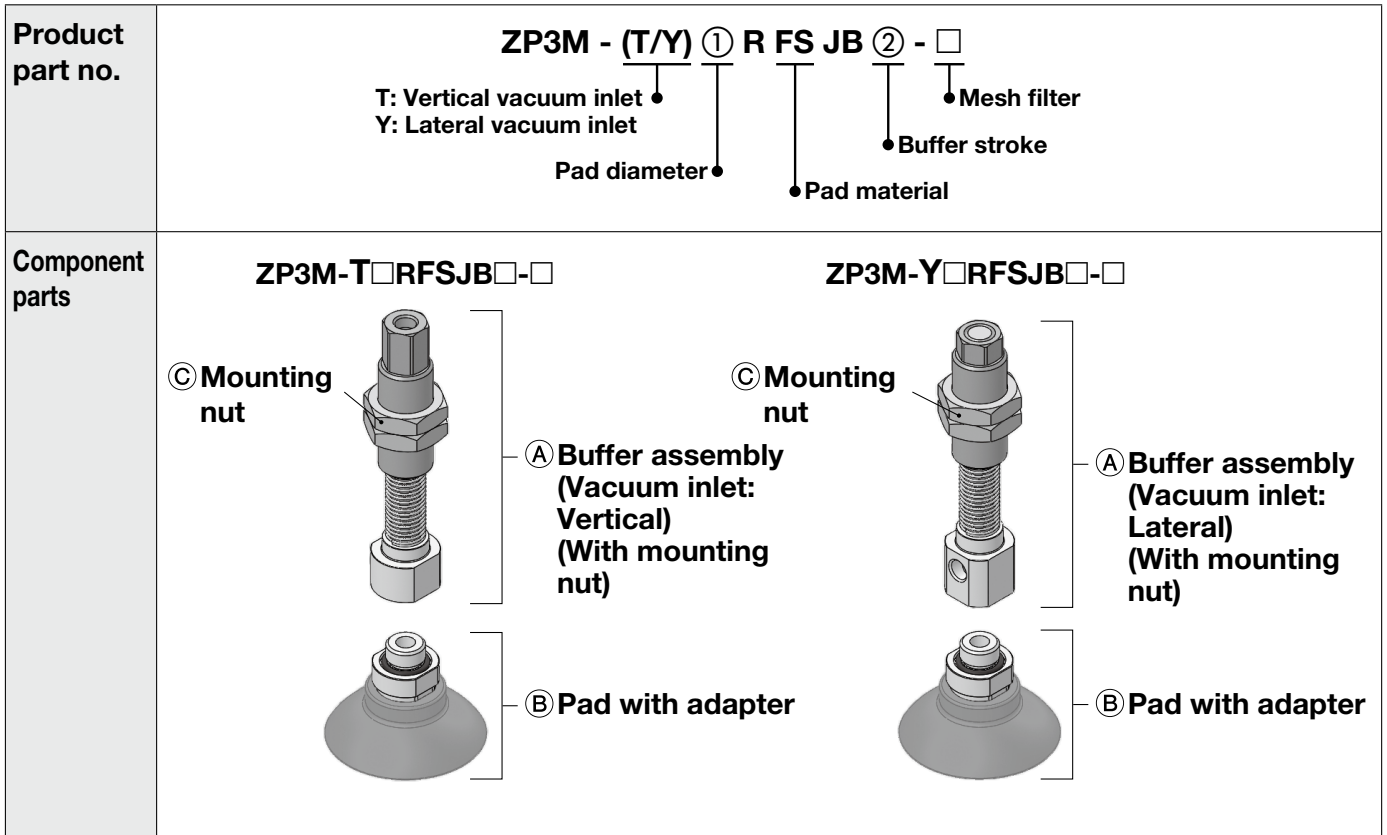

		Symbol	① Pad diameter					
			32	40	50	63	80	100
Ⓐ Buffer assembly (With mounting nut)	② Buffer stroke	10	ZP3EB-(T/Y)1JB②			ZP3EB-(T/Y)2JB②		
		30						
		50						
Ⓑ Pad with adapter	M10 x 1.0	ZP3M-T32RFS-A10-□	ZP3M-T40RFS-A10-□	ZP3M-T50RFS-A10-□	-			
	M16 x 1.5	-			ZP3M-T63RFS-A16-□	ZP3M-T80RFS-A16-□	ZP3M-T100RFS-A16-□	
Ⓒ Mounting nut (Single unit)	M18 x 1.5	ZPNA-M18						
	M22 x 1.5	-						
			ZPNA-M22					

[Buffer assembly part number example]

Product part no. **ZP3M - T63RFS JB 10**

Buffer assembly **ZP3EB - T2 JB 10**

② Buffer stroke

Vacuum Pad/ Bowl Bellows Shape with Non-slip Feature ZP3M Series

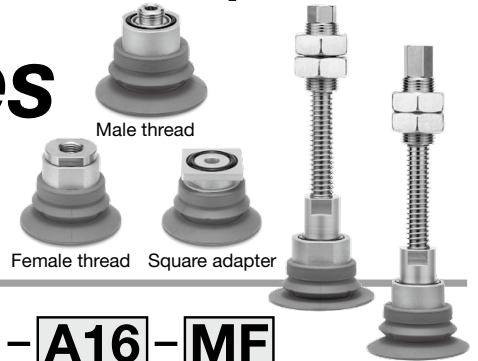

How to Order

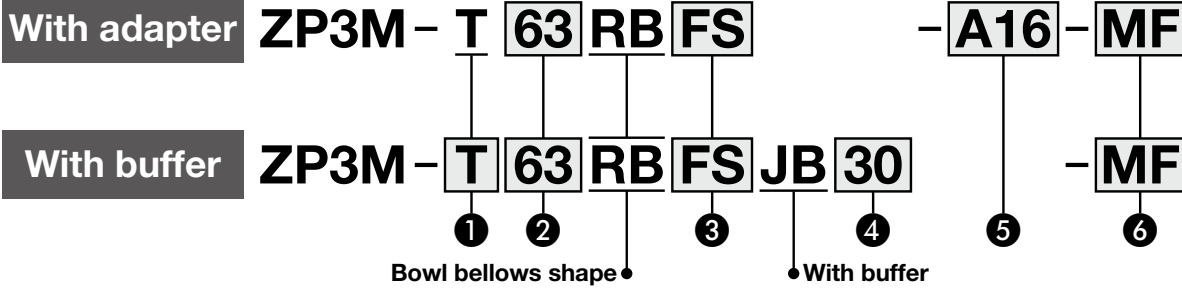

1 Vacuum inlet direction

T	Vertical
Y	Lateral

2 Pad diameter

50	ø50
63	ø63
80	ø80

3 Material

Symbol	Material	Color
FS	FS61 (Fluoro-based rubber)	Green

4 Buffer stroke

Stroke [mm]	Pad size	
	All sizes	
10	●	
30	●	
50	●	

5 Connection thread and type

Mounting	Type	Symbol	Size	Pad diameter	
				ø50	ø63, ø80
Direct mounting	Male thread	A10	M10 x 1.0	●	—
		A16	M16 x 1.5	—	●
		AG02	G1/4	●	●
	Female thread	BG02	G1/4	●	●
		BG03	G3/8	●	●
		S32	□31.8	●	●

6 Mesh filter

Nil	None
MF	With mesh filter

Mesh filter unit

Part no.	Pad diameter	
	ø50	ø63, ø80
ZPMF-60-D13	●	—
ZPMF-60-D18	—	●

* The adapter and pad are adhered to each other and cannot be disassembled.

Specifications

Pad Material

Material	FS61 (Fluoro-based rubber)
Color of rubber	Green
Rubber hardness (Shore A: ±5°)	60
Operating temperature range*1	0°C to 200°C
Ambient temperature	0°C to 150°C

*1 Surface temperature of the workpiece to be adsorbed

Adapter Specifications

Connection	Male thread		Female thread	Square adapter
Pad diameter	ø50	ø63, ø80	ø50 to ø80	ø50 to ø80
Size	M10 x 1.0 G1/4	M16 x 1.5 G1/4	G1/4 G3/8	□31.8
Vacuum inlet	Use the connection thread and type.			

Buffer Specifications

Pad diameter	ø50			ø63, ø80				
	JB: Rotating, With bushing			JB: Rotating, With bushing				
Stroke [mm]	10	30	50	10	30	50		
Connection thread	M18 x 1.5			M22 x 1.5				
Spring reactive force	At 0 stroke			10.0				
	At full stroke			6.5	8.5	10.5	11.5	13.5

Pad Specifications

Part no.	Horizontal holding force [N]*1		Minimum curvature radius for adsorption [mm]*2
	Without oil	With oil	
ZP3M-T50RBFS	63	46	27.5
ZP3M-T63RBFS	86	59	27.5
ZP3M-T80RBFS	122	91	34

*1 These are actual measurement values when flat workpieces were adsorbed at a setting vacuum pressure of -60 kPa; however, they are not guaranteed values. (According to SMC's tests)
The values vary depending on the conditions (shape, surface roughness, oil type, oil amount, and other conditions) of the workpiece.

*2 These are actual measurement values when cylindrical workpieces were adsorbed at a setting vacuum pressure of -85 kPa; however, they are not guaranteed values. (According to SMC's tests)

Mesh Filter Specifications

Mesh filter	60
Opening	250 μm

Buffer assembly part no. p. 17

Dimensions/Models

With adapter Direct mounting type (Male thread)

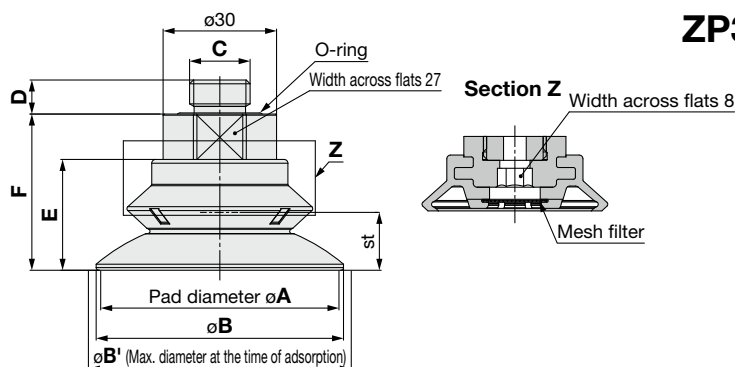

ZP3M - T **63** **RB** **FS** - **A16** - **MF**

① ② ③ ④



		Pad diameter [mm]	
		ø50	ø63, ø80
A10	M10 x 1.0	○	-
A16	M16 x 1.5	-	○
AG02	G1/4	○	○

Model							A	B	B' ^{*2}	C	D	E	F	st ^{*2}	Min. opening hole size of the adapter	Weight [g]
Vacuum inlet direction	① Pad diameter	Form	② Material ^{*1}	③ Connection thread	④ Mesh filter											
ZP3M	T	RB	FS	A10	Nil MF	50	52.4	55.6	M10 x 1.0	7	24.9	36.9	11.8	ø5	68.6	
				AG02					G1/4	6.5						
				63		65.4	69.5	M16 x 1.5	9	29.3	41.3	15.2				
								AG02	G1/4				6.5			
				80		82.6	87.5	M16 x 1.5	9	37.9	49.9	22.1				
								AG02	G1/4				6.5			

*1 FS: FS61 (Fluoro-based rubber)

*2 B': Maximum pad diameter at the time of adsorption, st: The stroke is a guide value at the setting vacuum pressure of -90 kPa.

With adapter Direct mounting type (Female thread)

Connection thread: BG02

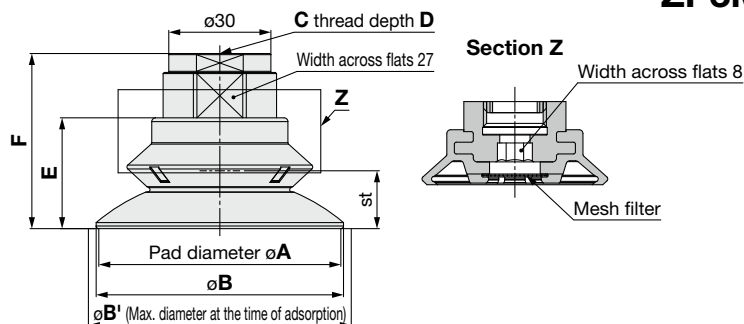

ZP3M - T **63** **RB** **FS** - **BG02** - **MF**

① ② ③ ④

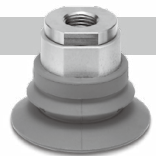

BG02	G1/4
BG03	G3/8

Connection thread: BG03

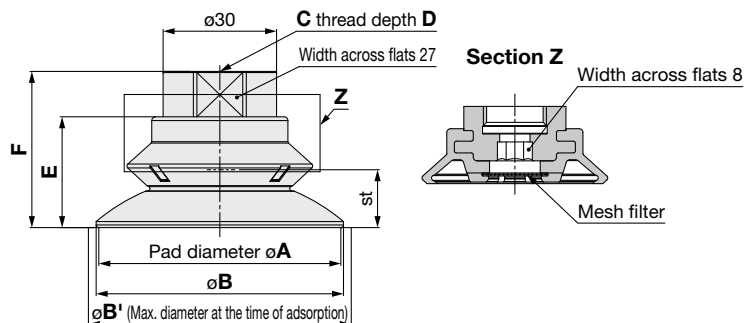

Model							A	B	B' ^{*2}	C	D	E	F	st ^{*2}	Min. opening hole size of the adapter	Weight [g]
Vacuum inlet direction	① Pad diameter	Form	② Material ^{*1}	③ Connection thread	④ Mesh filter											
ZP3M	T	RB	FS	BG02	Nil MF	50	52.4	55.6	G1/4	12.5	24.9	41.9	11.8	ø8	69.1	
				BG03					G3/8	11.4						
				63		65.4	59.5	G1/4	12.5	29.3	46.3	15.2				
								BG03	G3/8							11.4
				80		82.6	87.5	G1/4	12.5	37.9	54.9	22.1				
								BG03	G3/8							11.4

*1 FS: FS61 (Fluoro-based rubber)

*2 B': Maximum pad diameter at the time of adsorption, st: The stroke is a guide value at the setting vacuum pressure of -90 kPa.

ZP3M Series

Dimensions/Models

With adapter Direct mounting type (Square adapter)

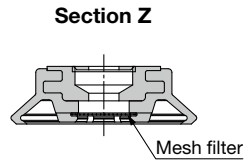
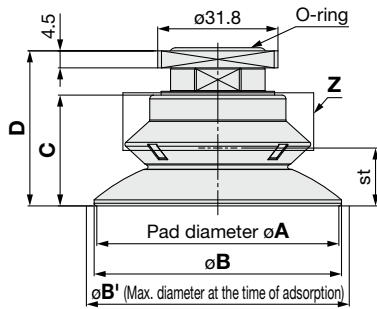

ZP3M - T **63** RB **FS** - S32 - **MF**

①

②

③

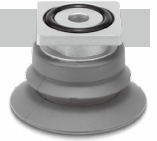

	Vacuum inlet direction	Model					A	B	B ¹ *2	C	D	st*2	Min. opening hole size of the adapter	Weight [g]
		① Pad diameter	Form	② Material *1	Connection thread	③ Mesh filter								
ZP3M	T	50	RB	FS	S32	Nil MF	50	52.4	55.6	24.9	36.6	11.8	ø8	50.0
		63					63	65.4	69.5	29.3	41	15.2		59.8
		80					80	82.6	87.5	37.9	49.6	22.1		92.8

*1 FS: FS61 (Fluoro-based rubber)

*2 B¹: Maximum pad diameter at the time of adsorption, st: The stroke is a guide value at the setting vacuum pressure of -90 kPa.

Square adapter mounting groove dimensions (Recommended)

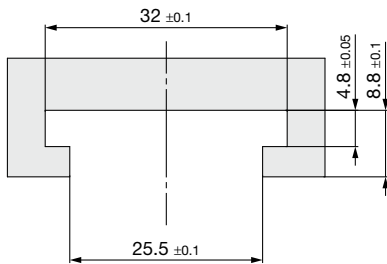

* For details on how to use the square adapter, refer to "Mounting" on page 18.

Dimensions/Models

With buffer Plate mounting type (Vacuum inlet direction: Vertical)

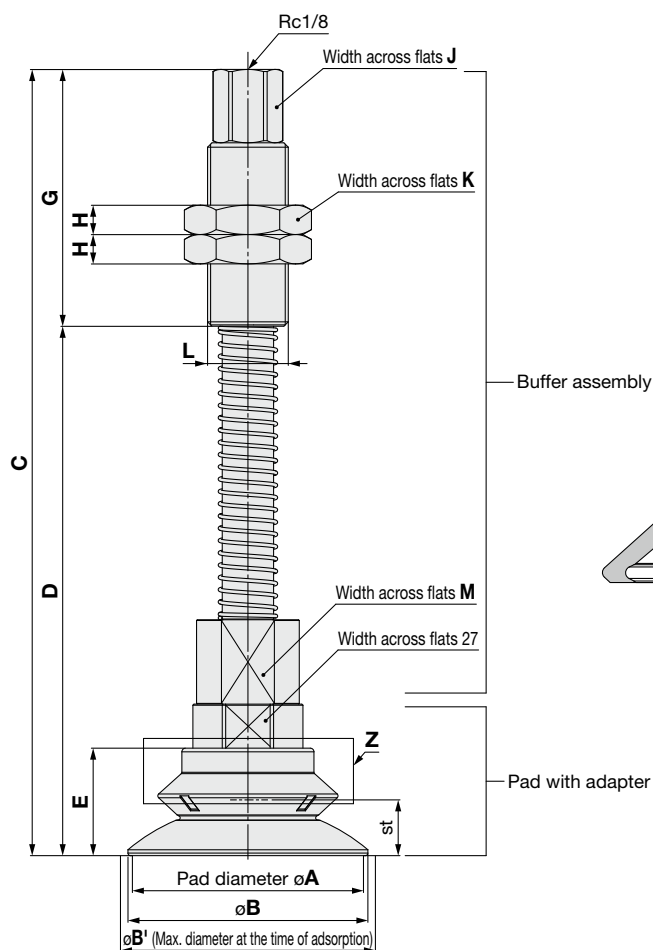

ZP3M - T **63** **RB** **FS** **JB** **10** - **MF**

① ② ③ ④ ⑤

JB Rotating, With bushing

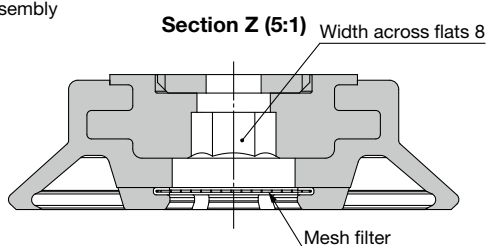

Model								A	B	B ^{*2}	C	D	E	G	H	J	K	L	M	st ^{*2}	Min. opening hole size	Weight [g]			
Vacuum inlet direction	① Pad diameter	Form	② Material ^{*1}	③ Buffer spec.	④ Buffer stroke	⑤ Mesh filter																			
ZP3M	T	50	RB	FS	JB	10	Nil	50	52.4	55.6	136.4	84.4	24.9	35	11	14	27	M18 x 1.5	16	11.8	ø3	259.7			
						30					161.4	109.4										274.2			
						50					181.4	129.4										285.6			
						10					169.3	99.3										399.1			
						30					194.3	124.3										427.9			
						50					214.3	144.3										450.8			
	80	80	82.6	87.5	10	Nil	80	82.6	87.5	202.9	132.9	222.9	152.9	37.9	50	8	17	30	M22 x 1.5	24	22.1	ø4	432.2		
					30																		202.9	132.9	460.9
					50																		222.9	152.9	483.9

*1 FS: FS61 (Fluoro-based rubber)

*2 B': Maximum pad diameter at the time of adsorption, st: The stroke is a guide value at the setting vacuum pressure of -90 kPa.

ZP3M Series

Dimensions/Models

With buffer Plate mounting type (Vacuum inlet direction: Lateral)

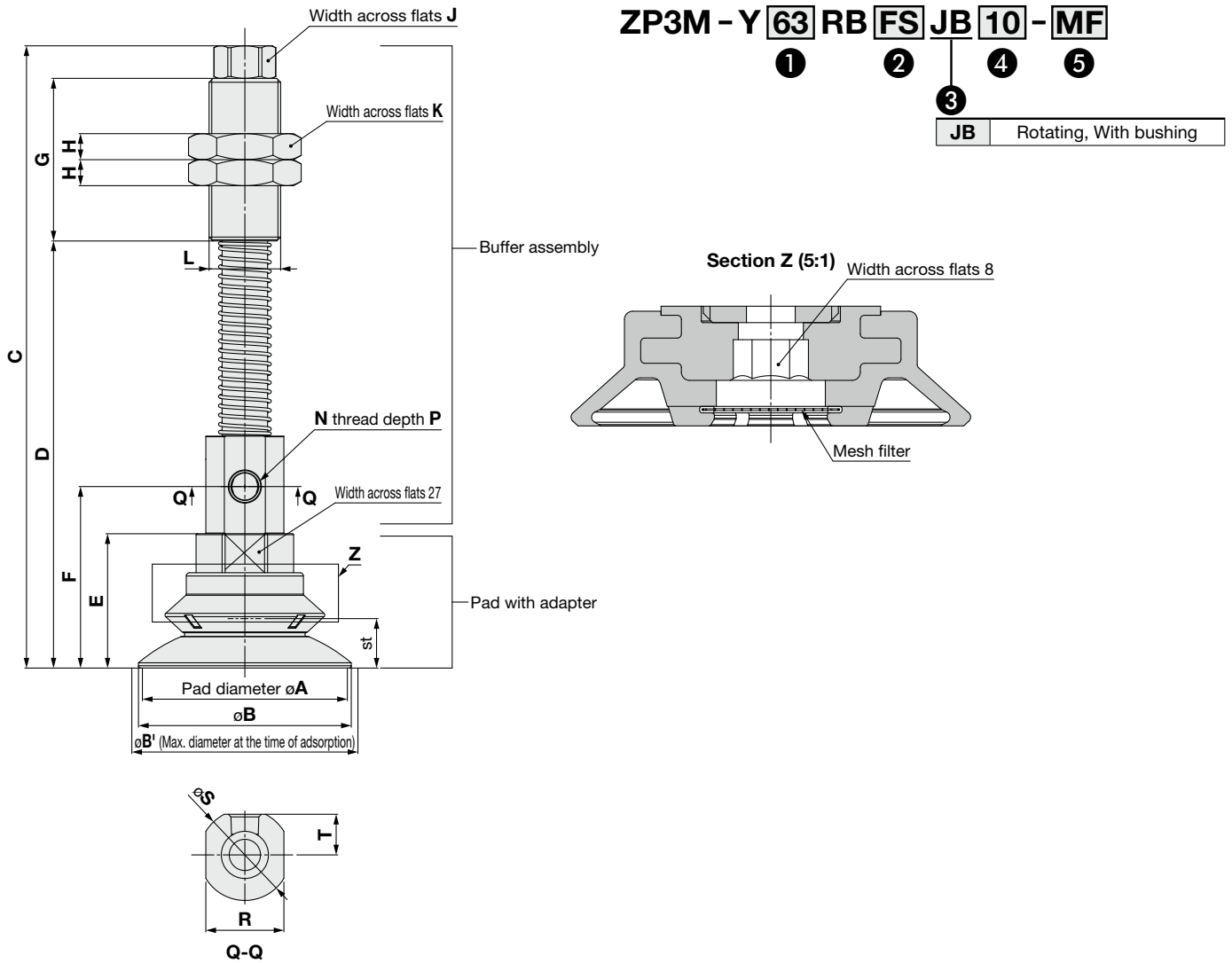

Model							A	B	B' ^{*2}	C	D	E	F	G	H	J	K	L	N	P	R	S	T	st ^{*2}	Min. opening hole size	Weight [g]
Vacuum inlet direction	① Pad diameter	Form	② Material *1	③ Buffer spec.	④ Buffer stroke	⑤ Mesh filter																				
ZP3M	Y	RB	FS	JB	10	Nil MF	50	52.4	55.6	131.4	87.4	24.9	46.8	35	11	14	27	M18 x 1.5	M5 x 0.8	5	16	19	8.5	11.8	ø5	258.0
					30					156.4	112.4															273.9
					50					176.4	132.4															286.5
					10					166.3	106.3															400.3
					30					191.3	131.3															431.5
					50					211.3	151.3															456.4
	80	RB	FS	JB	10	Nil MF	80	82.6	87.5	174.9	114.9	37.9	64.4	50	8	17	30	M22 x 1.5	Rc1/8	-	24	28	12.5	22.1	ø6	433.3
					30					199.9	139.9															464.5
					50					219.9	159.9															489.4

*1 FS: FS61 (Fluoro-based rubber)

*2 B': Maximum pad diameter at the time of adsorption, st: The stroke is a guide value at the setting vacuum pressure of -90 kPa.

Construction

With adapter

ZP3M-T□RBFS-A□

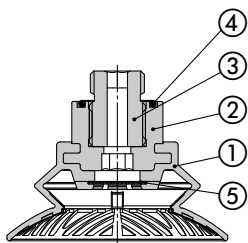

ZP3M-T□RBFS-S32

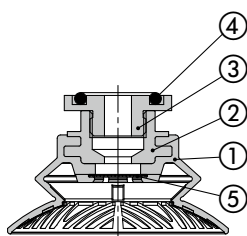

ZP3M-T□RBFS-BG02

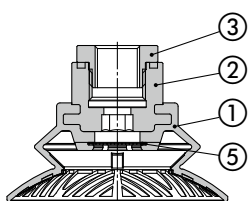

ZP3M-T□RBFS-BG03

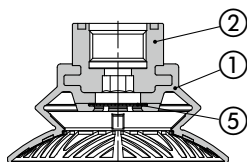

Component Parts

No.	Description	Material	Note
1	Pad	FS61 (Fluoro-based rubber)	—
2	Insert adapter	Aluminum alloy	—
3	Adapter	Structural carbon steel (Electroless nickel plating)	For ZP3M-T□RBFS-A□ ZP3M-T□RBFS-BG02
		Aluminum alloy (Anodized)	For ZP3M-T□RBFS-S32
4	O-ring	FKM	—
5	Mesh filter	Stainless steel	—

* The parts 1, 2, and 3 are adhered to each other and cannot be disassembled.

With buffer

ZP3M-T□RBFSJB□-□

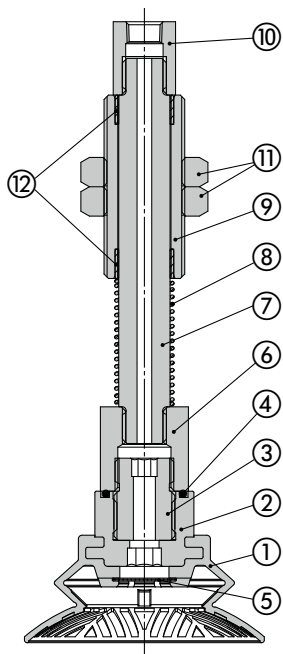

ZP3M-Y□RBFSJB□-□

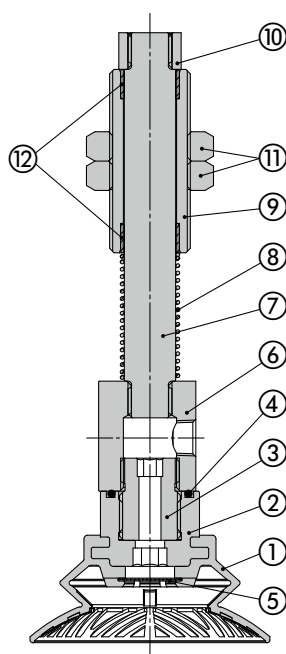

Component Parts

No.	Description	Material	Note
1	Pad	FS61 (Fluoro-based rubber)	—
2	Insert adapter	Aluminum alloy	—
3	Adapter	Structural carbon steel (Electroless nickel plating)	—
4	O-ring	FKM	—
5	Mesh filter	Stainless steel	—
6	Adapter	Aluminum alloy (Anodized)	—
7	Piston rod	Structural steel (Hard chrome plating)	—
8	Return spring	Stainless steel	—
9	Buffer body	Brass (Electroless nickel plating)	—
10	Buffer adapter	Brass (Electroless nickel plating)	—
11	Nut	Steel (Zinc chromated) M18 x 1.5	—
		Structural steel (Nickel plating) M22 x 1.5	—
12	Bushing	—	—

* The parts 1, 2, and 3 are adhered to each other and cannot be disassembled.

Replacement Parts: Mesh Filter Unit

Part no.	Pad diameter	
	ø50	ø63, ø80
ZPMF-60-D13	●	—
ZPMF-60-D18	—	●



ZP3M Series

Mounting Bracket Assembly

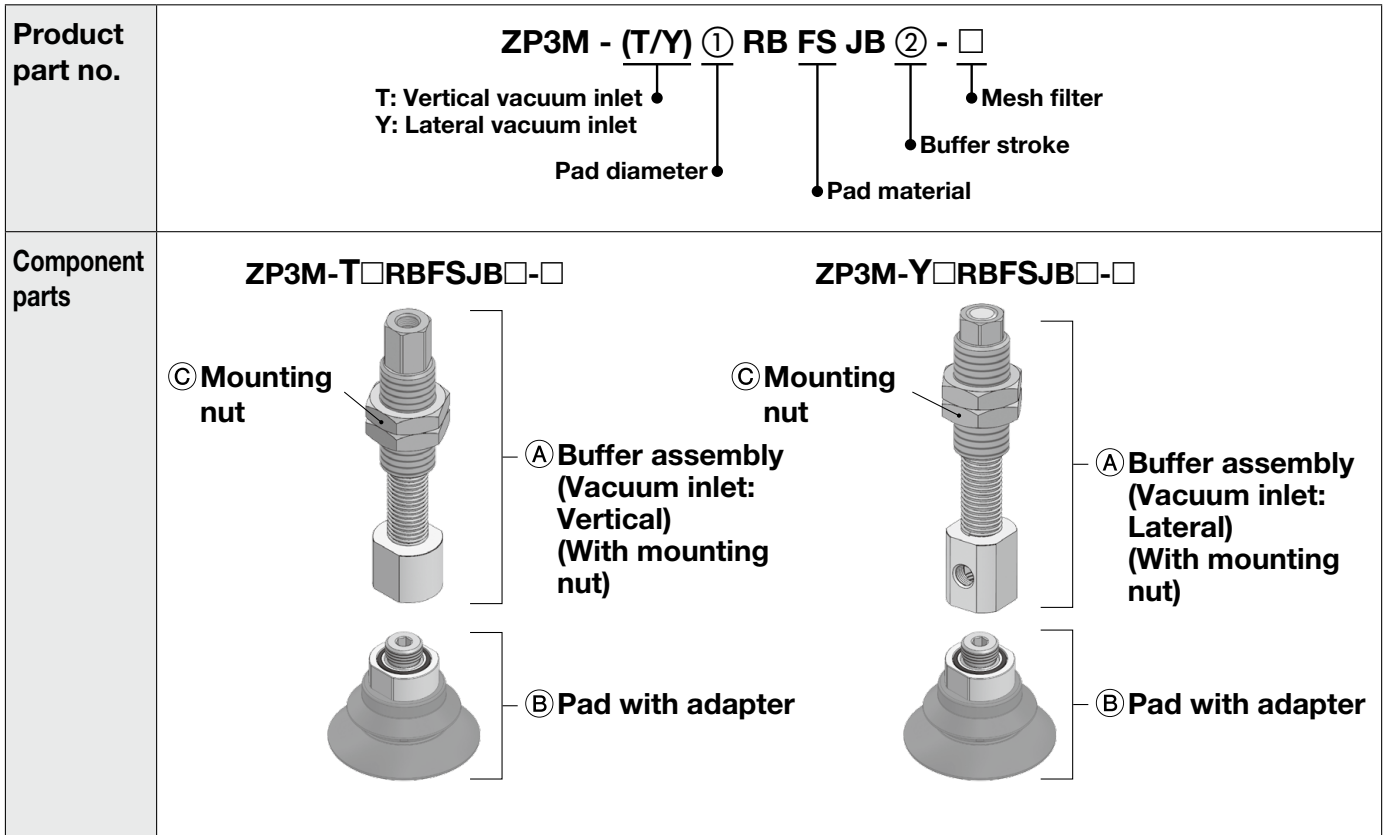

		Symbol	① Pad diameter		
			50	63	80
Ⓐ Buffer assembly (With mounting nut)	② Buffer stroke	10	ZP3EB-(T/Y)1JB②	ZP3EB-(T/Y)2JB②	
		30			
		50			
Ⓑ Pad with adapter	M10 x 1.0	ZP3M-T50RBFS-A10-□	-		
	M16 x 1.5	-	ZP3M-T63RBFS-A16-□	ZP3M-T80RBFS-A16-□	
Ⓒ Mounting nut (Single unit)	M18 x 1.5	ZPNA-M18	-		
	M22 x 1.5	-	ZPNA-M22		

[Buffer assembly part number example]

Product part no. **ZP3M - T63RBFS JB 10**

Buffer assembly **ZP3EB - T2 JB 10**

② Buffer stroke



ZP3M Series

Vacuum Pad/Specific Product Precautions

Be sure to read this before handling the products. Refer to the back cover for safety instructions. For vacuum equipment precautions, refer to the “Handling Precautions for SMC Products” and the “Operation Manual” on the SMC website.

Design

1. Before use, please check the transfer conditions with the customer’s actual equipment.

The transfer ability varies depending on the workpiece material, the friction between the pad and workpiece, moment, wind, vibration, etc. Testing with the customer’s actual equipment is necessary.

2. In cases where the workpieces are heavy or dangerous objects, etc., take measures to address a possible loss of adsorption force (installation of a drop prevention guide, etc.).

3. The oil, chemical, and other substances adhered to the workpiece may not be suitable for the pad material.

Before using this product, sufficiently verify the workpieces in your operating environment.

Mounting

1. When mounting the product, tighten with the tightening torque shown in the table below.

If excessive or insufficient tightening torque is applied, sealing failure or loose screws may result.

When using a product equipped with a buffer, if the buffer is tightened to a torque beyond the appropriate tightening torque range, the buffer may malfunction.

With Adapter (Male thread type)

Model	Connection thread size	Proper tightening torque [N·m]
ZP3M-T□(R,RB)FS-A10-□	M10 x 1.0	8 to 10
ZP3M-T□(R,RB)FS-A16-□	M16 x 1.5	13 to 15
ZP3M-T□(R,RB)FS-AG02-□	G1/4	8 to 12

With Adapter (Female thread type)

Model	Connection thread size	Proper tightening torque [N·m]
ZP3M-T□RFS-B14-□	M14 x 1.0	11 to 13
ZP3M-T□(R,RB)FS-BG02-□	G1/4	8 to 12
ZP3M-T□(R,RB)FS-BG03-□	G3/8	15 to 20

With Buffer

Model	Connection thread size	Proper tightening torque [N·m]
ZP3M-(T/Y)□(R,RB)FSJB□-□	M18 x 1.5	28 to 32
	M22 x 1.5	45 to 50

2. How to use the square adapter

Use the square adapter by inserting it to an attachment you prepare. If it is difficult to insert the square adapter, apply grease to the O-ring. Prepare retaining measures by yourself.

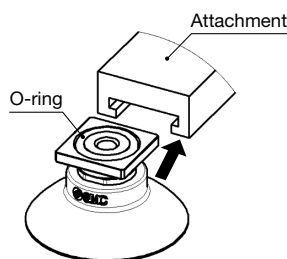

Handling

1. Depending on the type of oil or foreign matter, the mesh filter may be clogged at an early stage.

Before using this product, sufficiently verify the mesh filter in your operating environment.

2. Periodically inspect the mesh filter.

An adsorbing malfunction may be caused by the clogging of the mesh filter.

3. When the vacuum pad is pressed, make sure it stays within the stroke range.

If this product is used with a stroke exceeding the maximum stroke, the pad may be broken or may reach the end of its service life earlier.

4. Vacuum pads are consumable. Please replace them when cracks or deformation is confirmed during periodic maintenance.

5. The workpiece size must be equal to or greater than the minimum curvature radius for adsorption.

If the workpiece size is smaller than the minimum curvature radius for adsorption, an adsorbing malfunction may occur.

6. As the adapter and pad are adhered to each other, they cannot be disassembled.

7. When adsorbing a plane, the pad skirt may be entrained depending on the workpiece with rough friction surface. Before using this product, sufficiently verify the adsorbing condition.

Safety Instructions

These safety instructions are intended to prevent hazardous situations and/or equipment damage. These instructions indicate the level of potential hazard with the labels of “**Caution**,” “**Warning**” or “**Danger**.” They are all important notes for safety and must be followed in addition to International Standards (ISO/IEC)*1), and other safety regulations.

 **Danger :** **Danger** indicates a hazard with a high level of risk which, if not avoided, will result in death or serious injury.

 **Warning:** **Warning** indicates a hazard with a medium level of risk which, if not avoided, could result in death or serious injury.

 **Caution:** **Caution** indicates a hazard with a low level of risk which, if not avoided, could result in minor or moderate injury.

*1) ISO 4414: Pneumatic fluid power - General rules and safety requirements for systems and their components
ISO 4413: Hydraulic fluid power - General rules and safety requirements for systems and their components
IEC 60204-1: Safety of machinery - Electrical equipment of machines - Part 1: General requirements
ISO 10218-1: Robots and robotic devices - Safety requirements for industrial robots - Part 1: Robots etc.

Warning

1. The compatibility of the product is the responsibility of the person who designs the equipment or decides its specifications.

Since the product specified here is used under various operating conditions, its compatibility with specific equipment must be decided by the person who designs the equipment or decides its specifications based on necessary analysis and test results. The expected performance and safety assurance of the equipment will be the responsibility of the person who has determined its compatibility with the product. This person should also continuously review all specifications of the product referring to its latest catalog information, with a view to giving due consideration to any possibility of equipment failure when configuring the equipment.

2. Only personnel with appropriate training should operate machinery and equipment.

The product specified here may become unsafe if handled incorrectly. The assembly, operation and maintenance of machines or equipment including our products must be performed by an operator who is appropriately trained and experienced.

3. Do not service or attempt to remove product and machinery/equipment until safety is confirmed.

1. The inspection and maintenance of machinery/equipment should only be performed after measures to prevent falling or runaway of the driven objects have been confirmed.
2. When the product is to be removed, confirm that the safety measures as mentioned above are implemented and the power from any appropriate source is cut, and read and understand the specific product precautions of all relevant products carefully.
3. Before machinery/equipment is restarted, take measures to prevent unexpected operation and malfunction.

4. Our products cannot be used beyond their specifications. Our products are not developed, designed, and manufactured to be used under the following conditions or environments. Use under such conditions or environments is not covered.

1. Conditions and environments outside of the given specifications, or use outdoors or in a place exposed to direct sunlight.
2. Use for nuclear power, railways, aviation, space equipment, ships, vehicles, military application, equipment affecting human life, body, and property, fuel equipment, entertainment equipment, emergency shut-off circuits, press clutches, brake circuits, safety equipment, etc., and use for applications that do not conform to standard specifications such as catalogs and operation manuals.
3. Use for interlock circuits, except for use with double interlock such as installing a mechanical protection function in case of failure. Please periodically inspect the product to confirm that the product is operating properly.

Caution

We develop, design, and manufacture our products to be used for automatic control equipment, and provide them for peaceful use in manufacturing industries.

Use in non-manufacturing industries is not covered.

Products we manufacture and sell cannot be used for the purpose of transactions or certification specified in the Measurement Act.

The new Measurement Act prohibits use of any unit other than SI units in Japan.

Limited warranty and Disclaimer/ Compliance Requirements

The product used is subject to the following “Limited warranty and Disclaimer” and “Compliance Requirements”.

Read and accept them before using the product.

Limited warranty and Disclaimer

1. The warranty period of the product is 1 year in service or 1.5 years after the product is delivered, whichever is first.*2)
Also, the product may have specified durability, running distance or replacement parts. Please consult your nearest sales branch.
2. For any failure or damage reported within the warranty period which is clearly our responsibility, a replacement product or necessary parts will be provided. This limited warranty applies only to our product independently, and not to any other damage incurred due to the failure of the product.
3. Prior to using SMC products, please read and understand the warranty terms and disclaimers noted in the specified catalog for the particular products.

*2) **Vacuum pads are excluded from this 1 year warranty.**

A vacuum pad is a consumable part, so it is warranted for a year after it is delivered.

Also, even within the warranty period, the wear of a product due to the use of the vacuum pad or failure due to the deterioration of rubber material are not covered by the limited warranty.

Compliance Requirements

1. The use of SMC products with production equipment for the manufacture of weapons of mass destruction (WMD) or any other weapon is strictly prohibited.
2. The exports of SMC products or technology from one country to another are governed by the relevant security laws and regulations of the countries involved in the transaction. Prior to the shipment of a SMC product to another country, assure that all local rules governing that export are known and followed.

Revision History

Edition B * Bowl bellows shape: ø50, ø63, and ø80 have been added.

* The number of pages has been increased from 12 to 20.

BZ

Safety Instructions

Be sure to read the “Handling Precautions for SMC Products” (M-E03-3) and “Operation Manual” before use.

SMC Corporation