

Power Clamp Cylinder

ø50, ø63

New

RoHS

A new structure has achieved downsizing.
Overall length **reduced by 49 mm max.**

Bore size	CKZ3T → New CKZ5T	Reduction
50	377 mm → 343 mm	34 mm
63	392 mm → 343 mm	49 mm

Depth **reduced by 17.3 mm max.**

Bore size	CKZ3T → New CKZ5T	Reduction
50	136 mm → 128.7 mm	7.3 mm
63	148.5 mm → 131.2 mm	17.3 mm

* When a proximity switch (by P&F) is attached

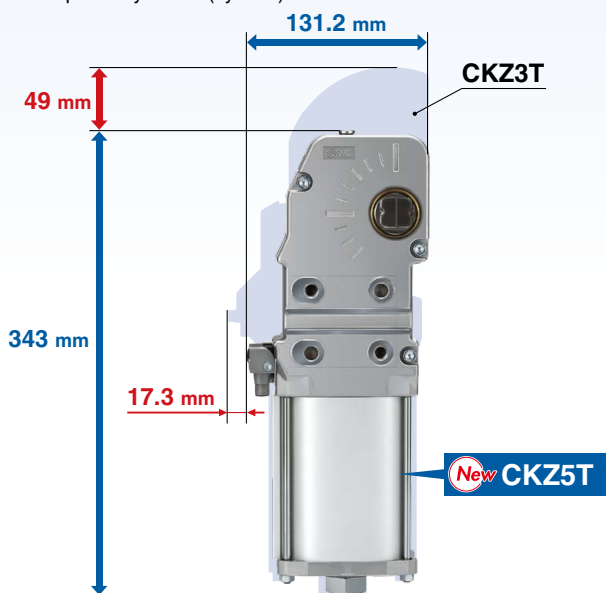

- Interchangeable with existing product CKZ3T in terms of installation

Weight **reduced by up to 23%**

- Aluminum body with greatly reduced weight

Bore size	CKZ3T → New CKZ5T	Reduction rate
50	3.1 kg → 2.8 kg	10%
63	4.3 kg → 3.3 kg	23%

* Arm opening angle: 90°

CKZ5T Series



High clamping force 4000 N

(ø63, Arm length: 100 mm, 0.5 MPa)

Manual lock release operability has been improved.

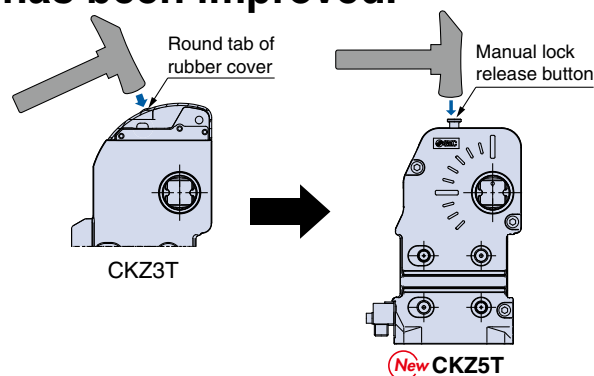

Spatter-proof construction

Fully enclosed structure by means of an aluminum body



CAT.ES20-284A

Power Clamp Cylinder

CKZ5T Series

ø50, ø63



How to Order

Base type

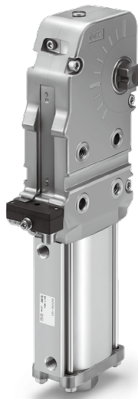

CKZ5T **50** - **90** **T**

• **Bore size**

50	ø50 equivalent
63	ø63 equivalent

• **Cylinder port**

Nil	G
TN	NPT
TP	Rc

• **Proximity switch**

T	TURCK
P	P&F
W	None

• **Arm opening angle**

Symbol	Arm opening angle
15	15°
30	30°
45	45°
60	60°
75	75°
90	90°
105	105°
120	120°
135	135°

Clamp arm

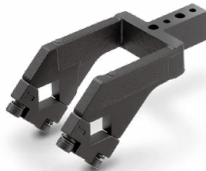

CKZT **50** - **A015** **C** **S**

• **Bore size**

50	ø50 equivalent
63	ø63 equivalent

• **Offset**

A015	Offset 15 mm
A045	Offset 45 mm

• **Mounting hole**

Symbol	D ₁	D ₂
S	6	9
B	8	10.2

• **Arm mounting position**

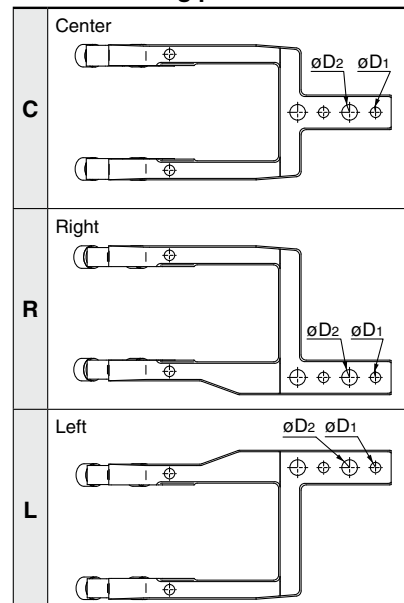

Mounted arm

Cylinder Specifications

Bore size	50	63
Action	Double acting	
Fluid	Air	
Proof pressure	0.9 MPa	
Max. operating pressure	0.6 MPa	
Min. operating pressure	0.3 MPa	
Ambient and fluid temperatures	-10 to 60°C (No freezing)	
Cushion	Clamping side: None Unclamping side: Rubber bumper	
Operating time	Clamping: 1 s or more, Unclamping: 1 s or more	
Max. allowable holding moment*1	800 N·m	1500 N·m

*1 Refer to the maximum holding force (torque) while clamped with the operating air exhausted.
This is not the possible holding force (torque) for normal use.

Weight (Cylinder Without Clamp Arm)

Bore size	Arm opening angle								
	15°	30°	45°	60°	75°	90°	105°	120°	135°
50	2.9	2.9	2.9	2.9	2.8	2.8	2.8	2.8	2.8
63	3.4	3.4	3.4	3.3	3.3	3.3	3.3	3.3	3.3

[kg]

Cylinder Stroke

Bore size	Arm opening angle								
	15°	30°	45°	60°	75°	90°	105°	120°	135°
50	22.9	32.5	40.6	48.4	56.4	64.5	72.4	79.4	84.4
63	22.9	32.5	40.6	48.4	56.4	64.5	72.4	79.4	84.4

[mm]

Proximity Switch Specifications

Manufacturer	TURCK	P&F
Power supply voltage	10 to 30 VDC	10 to 30 VDC
Output	N.O., PNP	N.O., PNP
Continuous load current	150 mA	100 mA
Response frequency	30 Hz	25 Hz
Housing material	PBT	PA6, PBT
Output indication	Clamping side: Red Unclamping side: Yellow	Clamping side: Red Unclamping side: Yellow
Power supply indication	Green	Green
Connector	M12 connector	M12 connector

* Switch specifications correspond to the manufacturers' technical information.

Wiring Diagram (PNP Connection Circuit)

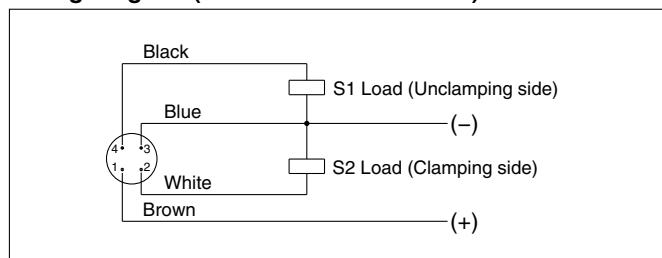

* Applicable to both TURCK and P&F

* Please contact SMC for NPN specifications.

CKZ5T Series

Replacement Parts

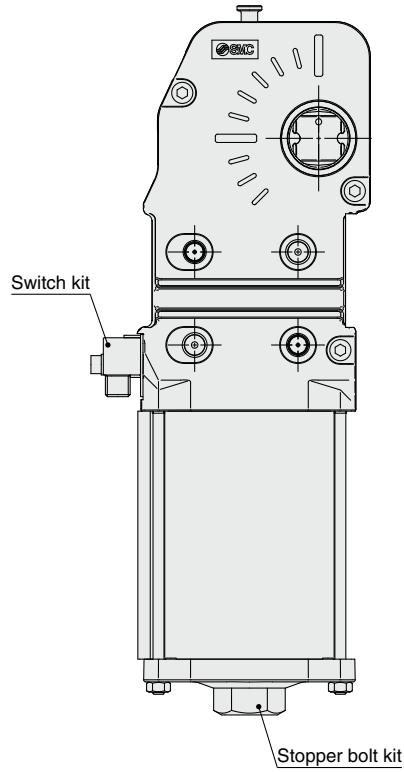

Switch Kit No.

CKZ5 - S063 **T**

● Proximity switch

T	TURCK
P	P&F
W	None

* The switch kit includes mounting brackets.

Stopper Bolt Kit No.

CKZ5 - B063 **D**

● Arm opening angle

J	15°
H	30°
G	45°
F	60°
E	75°
D	90°
C	105°
B	120°
A	135°

* The stopper bolt kit includes a stopper bolt and O-ring seal.

Dimensions

CKZ5T□-□

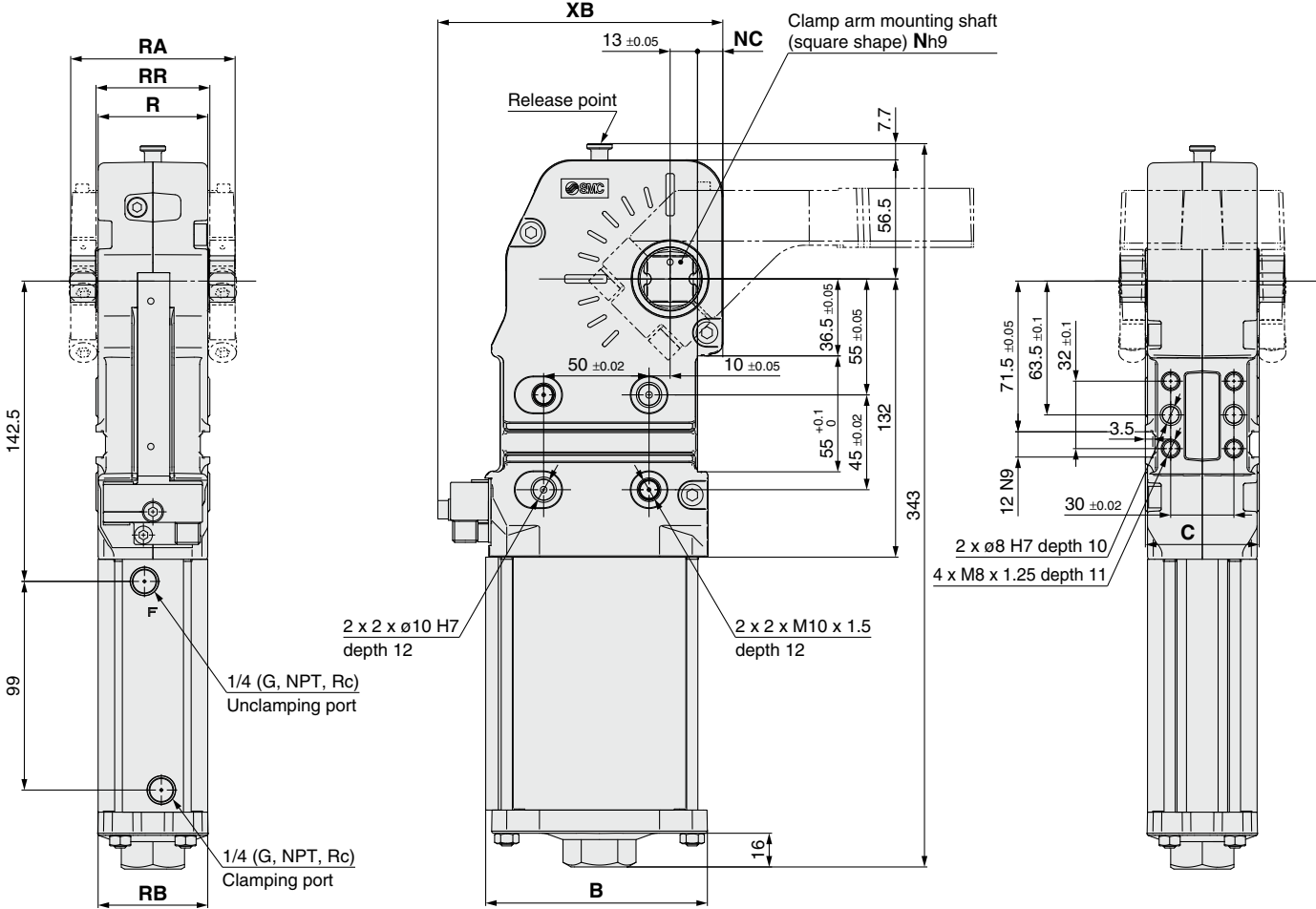

[mm]

Bore size	B	C	N	NC	R	RA	RB	RR	XB	
									With TURCK switch	With P&F switch
50	86	48	19	9.5	46.6	68	47	48	132.7	128.7
63	105	54	22	12	52	78	52	54	135.2	131.2

CKZ5T Series

Dimensions: Clamp Arm **Bore Size 50**

Offset 15 mm

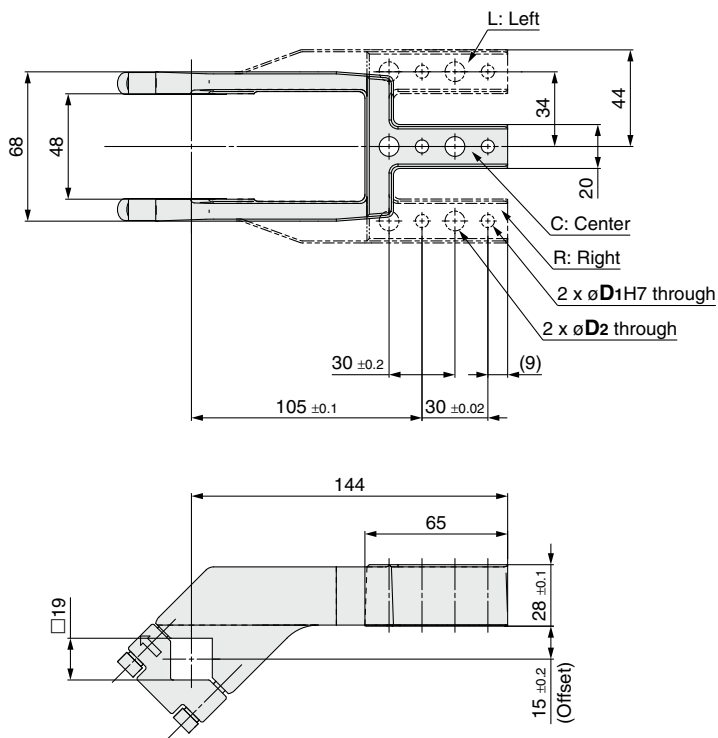

Model	D ₁	D ₂	Weight [kg]
CKZT50-A015CS	6	9	0.8
CKZT50-A015CB	8	10.2	0.8
CKZT50-A015RS	6	9	0.9
CKZT50-A015RB	8	10.2	0.9
CKZT50-A015LS	6	9	0.9
CKZT50-A015LB	8	10.2	0.9

Offset 45 mm

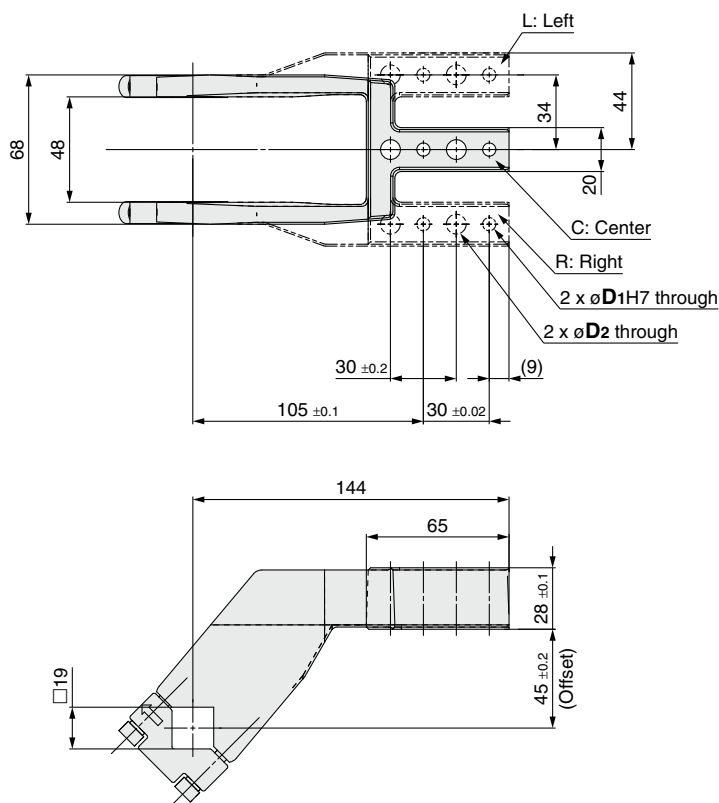

Model	D ₁	D ₂	Weight [kg]
CKZT50-A045CS	6	9	0.9
CKZT50-A045CB	8	10.2	0.9
CKZT50-A045RS	6	9	1.0
CKZT50-A045RB	8	10.2	1.0
CKZT50-A045LS	6	9	1.0
CKZT50-A045LB	8	10.2	1.0

Dimensions: Clamp Arm Bore Size 63

Offset 15 mm

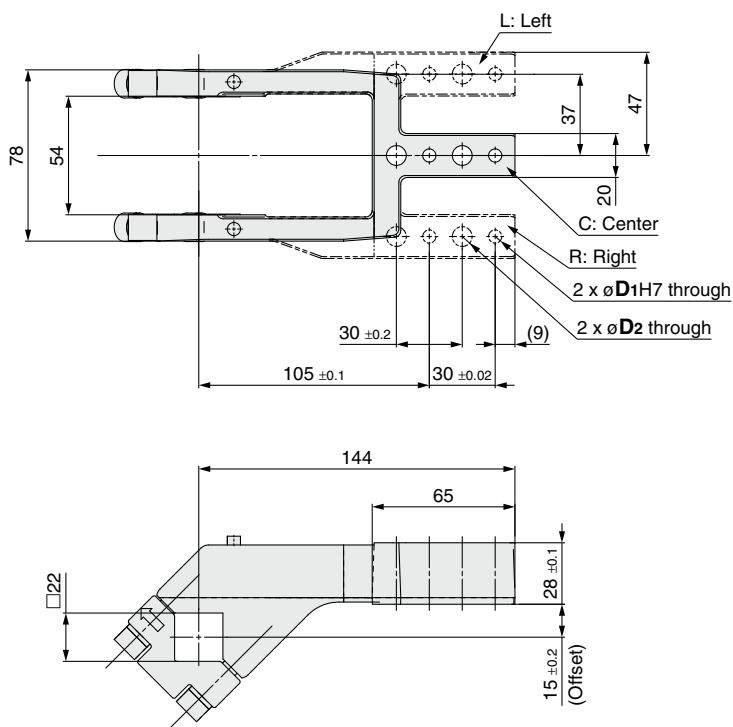

Model	D ₁	D ₂	Weight [kg]
CKZT63-A015CS	6	9	1.0
CKZT63-A015CB	8	10.2	1.0
CKZT63-A015RS	6	9	1.1
CKZT63-A015RB	8	10.2	1.1
CKZT63-A015LS	6	9	1.1
CKZT63-A015LB	8	10.2	1.1

Offset 45 mm

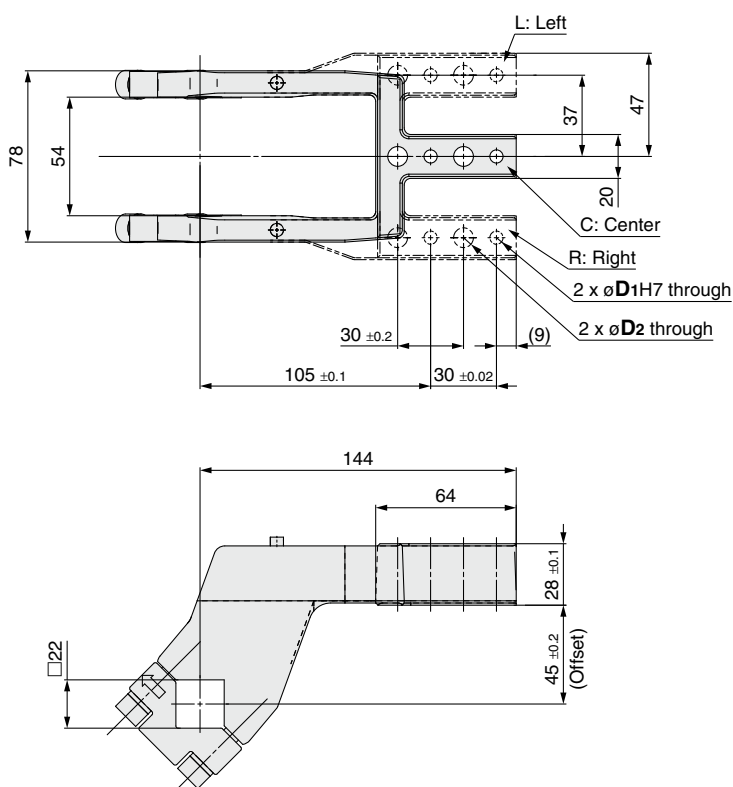

Model	D ₁	D ₂	Weight [kg]
CKZT63-A045CS	6	9	1.2
CKZT63-A045CB	8	10.2	1.2
CKZT63-A045RS	6	9	1.3
CKZT63-A045RB	8	10.2	1.2
CKZT63-A045LS	6	9	1.3
CKZT63-A045LB	8	10.2	1.2

CKZ5T Series Model Selection

Relation between arm length and clamping force

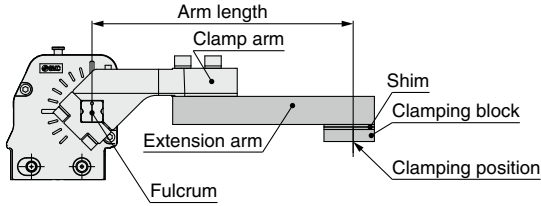

Bore Size: 50

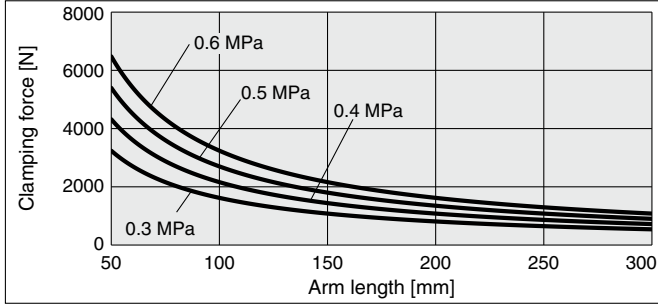

Bore Size: 63

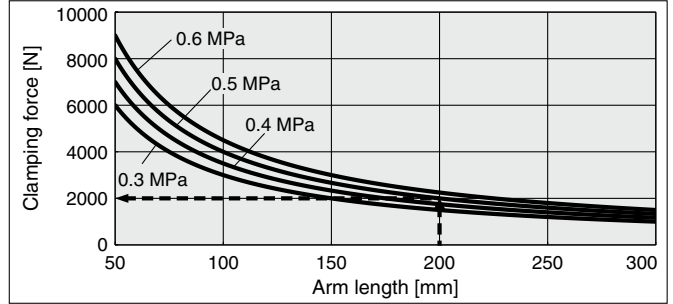

Calculation example Bore size: 63, Arm length: 200 mm, Operating pressure: 0.5 MPa

With an arm length of 200 mm and an operating pressure of 0.5 MPa, according to the graph, the maximum clamping force is 2000 N.

Allowable arm length

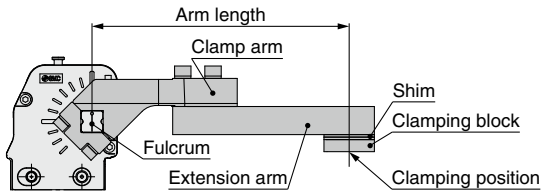

Bore size	Allowable arm length [mm]
50	300
63	300

Allowable load mass

The allowable load mass changes depending on the arm opening angle. Be sure to use the product within the allowable values shown in the graph below.
 * The load indicates the total weight of the clamp arm, extension arm, and clamping block.
 * When the operating time is 1 second

Calculation procedure for allowable load mass

- 1 Calculate the distance L from the fulcrum to the load center of gravity.
- 2 Check the arm opening angle of the product.
- 3 Read the allowable load mass from the graph.

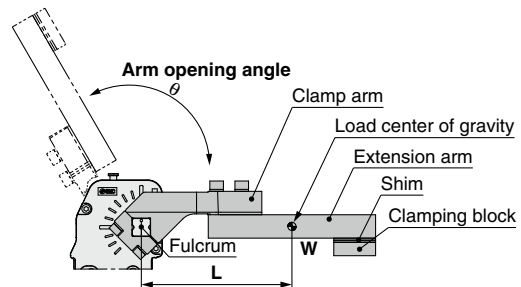

Bore Size: 50

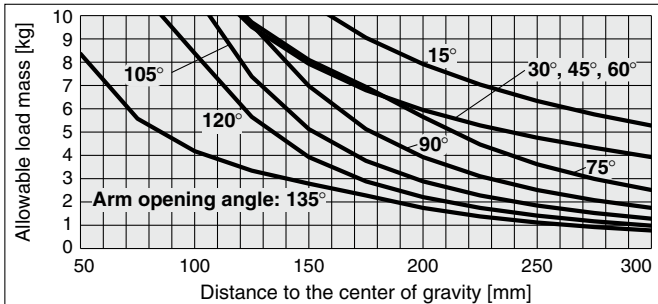

Bore Size: 63

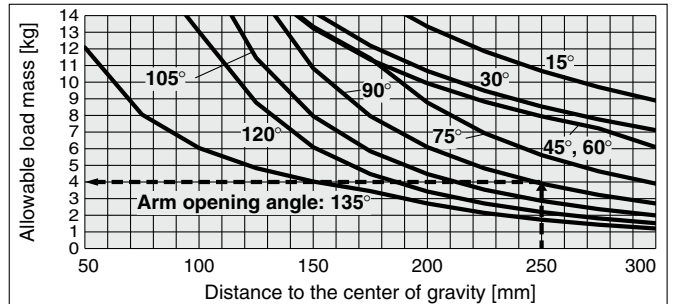

Calculation example Bore size: 63, Arm opening angle: 90°, Distance to the center of gravity L: 250 mm

With an arm opening angle of 90° and a 250 mm distance to the center of gravity, according to the graph, the maximum allowable load mass is 4.0 kg.

CKZ5T Series Setup Procedure

Precautions

- 1) The tightening torque of the clamp arm is 12 to 15 N·m for $\phi 50$ and 15 to 20 N·m for $\phi 63$. Refer to pages 5 and 6 for details on the clamp arm.
- 2) There is a mechanical difference of -0.25° to $+0.25^\circ$ at the clamping end as shown in Figure 1. Be sure to make adjustments externally using a shim. Refer to page 10.
- 3) Be sure to use a speed controller, and make adjustments according to the following conditions.

Unclamping to clamping: 1 second or more

Clamping to unclamping: 1 second or more

If excessive kinetic energy is applied, there is a possibility of damage.

- 4) When using a side guide (Figure 2):

Attach the side guide so that lateral loads, such as galling, etc., are not applied to the clamp arm.

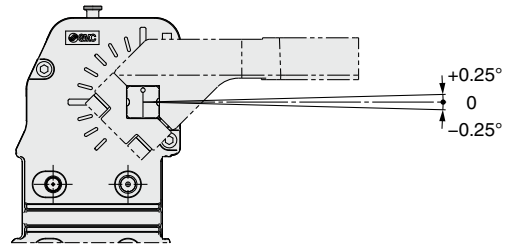

Figure 1

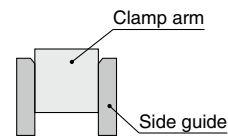
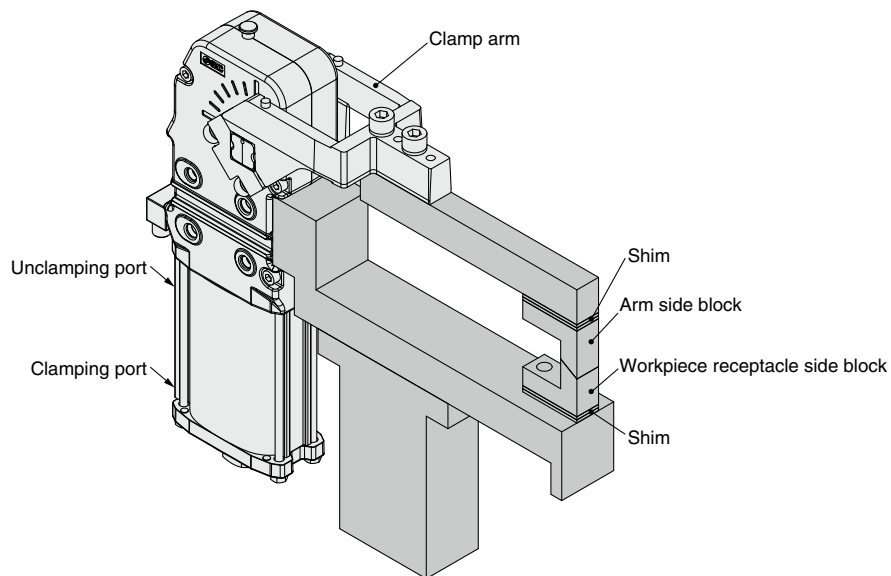

Figure 2

Power clamp cylinder mounting and setup procedure

<Ex. 1 When using clamping force only: When equipped with a workpiece receptacle>



Procedure

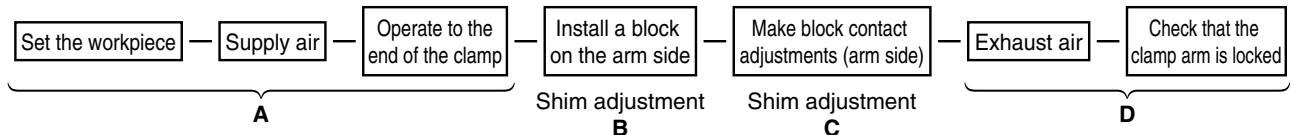

- A) Place the workpiece, supply air to the clamping port without attaching the block on the arm side, and operate the clamp arm to the end of the clamp.
- B) In the state of A), attach the workpiece and the arm side block, and adjust the shim so that there is a space of about 0 mm. During this step, theoretically, there is no clamping force pressing down on the workpiece.
- C) In order to generate a clamping force from the state described in step B), insert an additional shim. The thickness of the shim changes depending on the arm length and the operating pressure. Refer to page 10. Please note that the graph should only be used as a guide as there is a tolerance of about 10% in the clamp cylinder body.
- D) Exhaust the air while in the clamped state, and confirm that the clamp arm does not open.

Power clamp cylinder mounting and setup procedure

<Ex. 2 When using a hard stop: When not equipped with a workpiece receptacle>

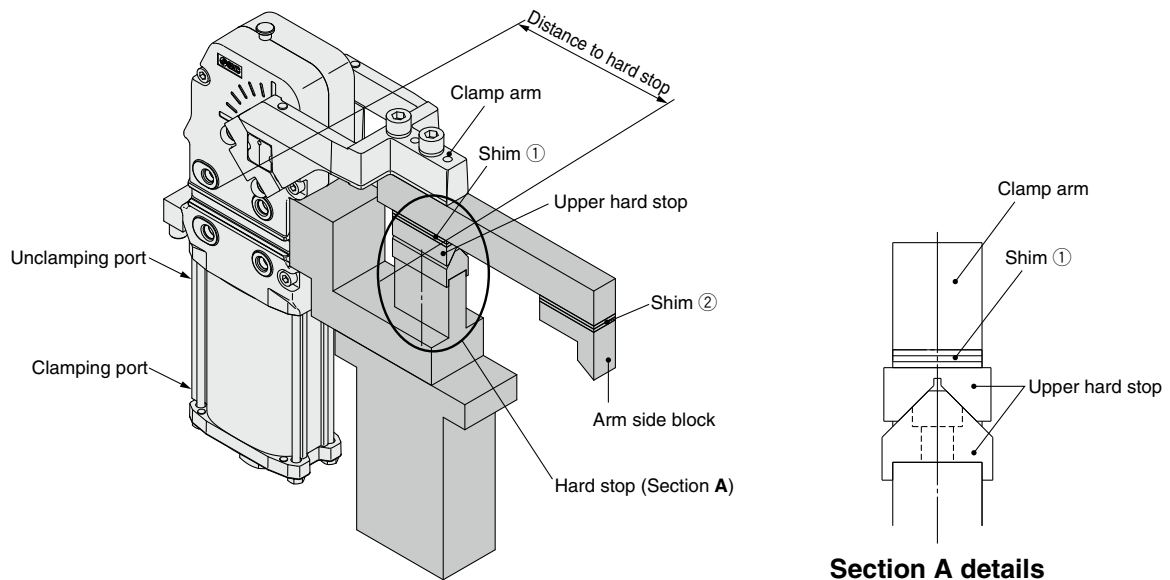

■ Procedure

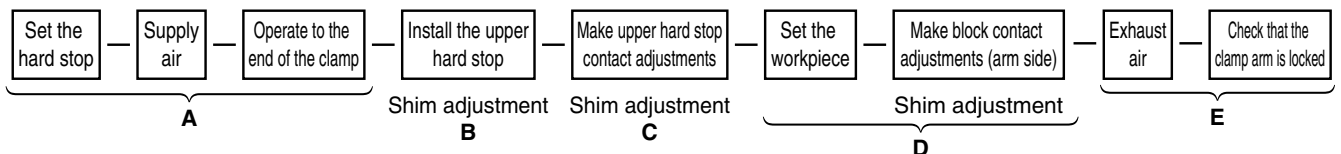

- A) Supply air to the clamping port without installing the upper hard stop, and operate the clamp arm to the end of the clamp.
- B) In the state of A), attach the upper hard stop and adjust shim ① so that there is a space of about 0 mm between the upper hard stop and the hard stop.
During this step, theoretically, there is no clamping force applied to the hard stop.
- C) In order to generate a clamping force from the state described in step B), insert an additional shim ①.
The thickness of the shim changes depending on the distance to the hard stop and the operating pressure. Refer to page 10, and consider the distance to the hard stop as the arm length.
Please note that the graph should only be used as a guide as there is a tolerance of about 10% in the clamp cylinder body.
- D) In the state of C), adjust shim ② so that the arm side block contacts the workpiece.
- E) Exhaust the air while in the clamped state, and confirm that the clamp arm does not open.

Relation between shim thickness and clamping force

- * Use this figure as a guide as there is a tolerance of about 10% in the clamp cylinder body.
- * When a shim exceeding the peak clamping force position on the graph is inserted, the lock will not be activated when clamped. Insert a shim of the appropriate thickness.
- *1 The arm length indicates the distance between the clamp arm shaft and the clamping position.

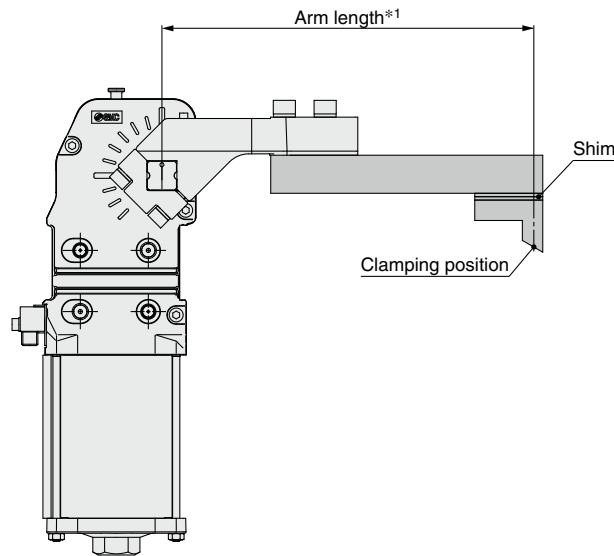

Bore Size: 50

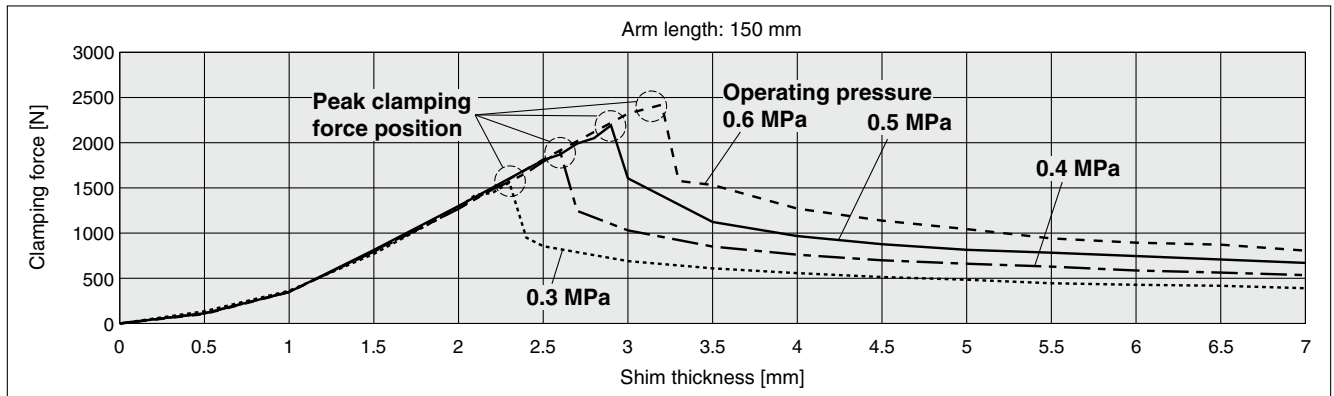

Bore Size: 63

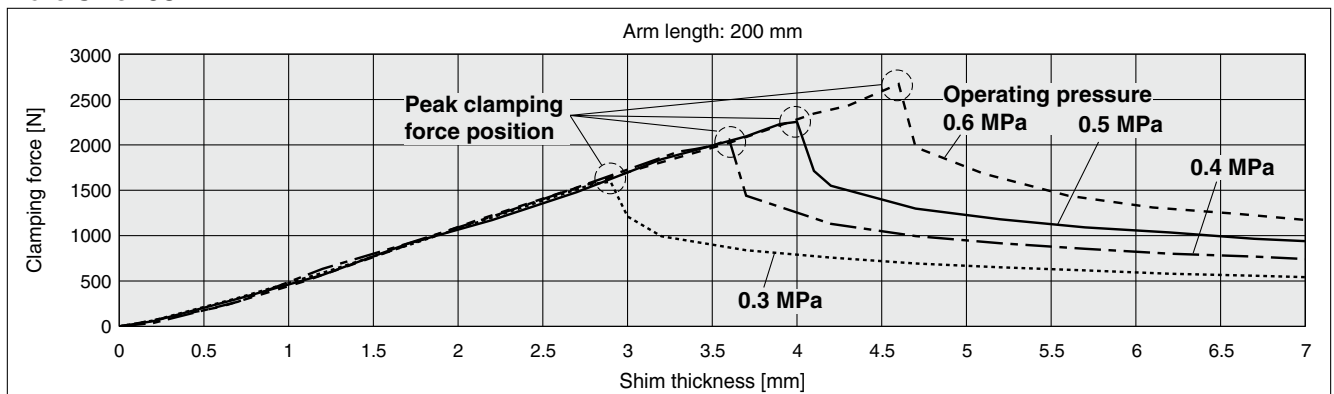

To change the arm opening angle

⚠ Caution Be sure to confirm safety, and perform the work while the air is exhausted.

1 Procedure for changing the stopper bolt

- 1) Remove the stopper bolt of the head cover, and replace with a stopper bolt for the desired angle using the tightening torque below. When tightening the stopper bolt, hold the head cover. Refer to Replacement Parts (page 3) for the part numbers of the applicable stopper bolts.

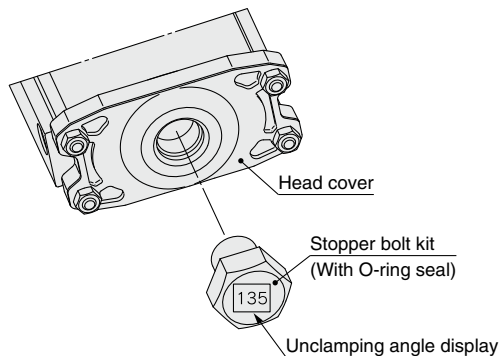

Stopper Bolt Tightening Torque

Bore size	Tightening torque [N·m]
50	45 to 65
63	45 to 65

2 Procedure for changing the switch position

- 1) Set the arm opening to 15° or above.
- 2) Loosen the switch cassette mounting bolt, and remove the switch cassette.
- 3) Remove the switch on the unclamping side, and attach it in the position of the desired angle. Store the lead wire in the storage space.
- 4) Mount the switch cassette to the body, and tighten the switch cassette mounting bolt to the tightening torque shown below. Refer to replacement parts switch kit no. (page 3) for the part numbers of the switch cassette replacement parts.

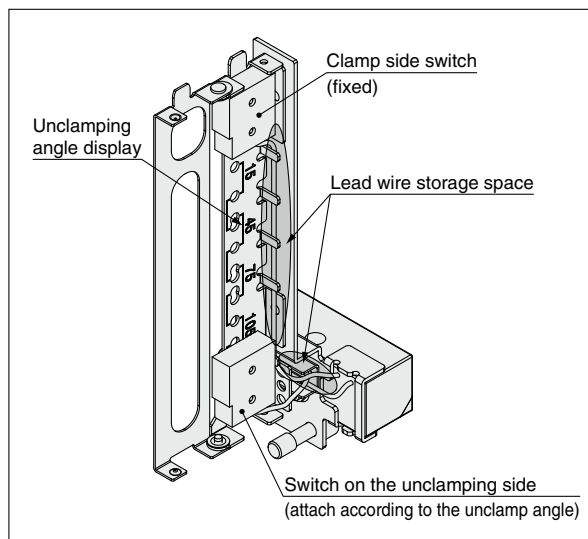
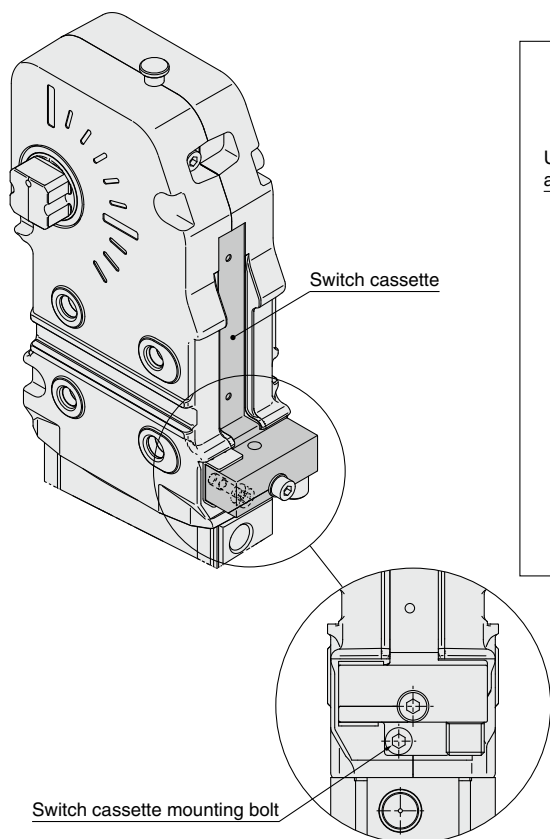

Inside of the switch cassette

Switch Cassette Mounting Bolt Tightening Torque

Bore size	Tightening torque [N·m]
50	3.0 to 4.0
63	3.0 to 4.0

Specific Product Precautions



Be sure to read this before handling the products. Refer to the back cover for safety instructions. For actuator precautions, refer to the “Handling Precautions for SMC Products” and the “Operation Manual” on the SMC website: <https://www.smcworld.com>

⚠ Caution

1. Manual lock release

Be sure to confirm safety before manually releasing the lock, and only perform work **while the air is exhausted**. Otherwise, the clamp arm may operate unexpectedly.

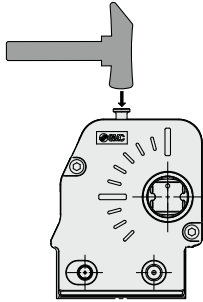

- Provide enough space to perform a manual lock release.

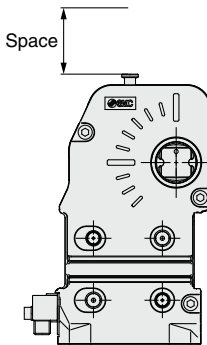

⚠ Caution

2. Do not disassemble the power clamp cylinder.

The power clamp cylinder consists of a completely sealed structure in order to protect it from welding spatter. Do not disassemble, except for when replacing any of the replaceable parts, as this may cause the performance to deteriorate.

3. Vertical clamping

When mounting the clamp arm in a vertical clamping position, mount as shown in the figure below. The maximum arm opening angle is 105°.

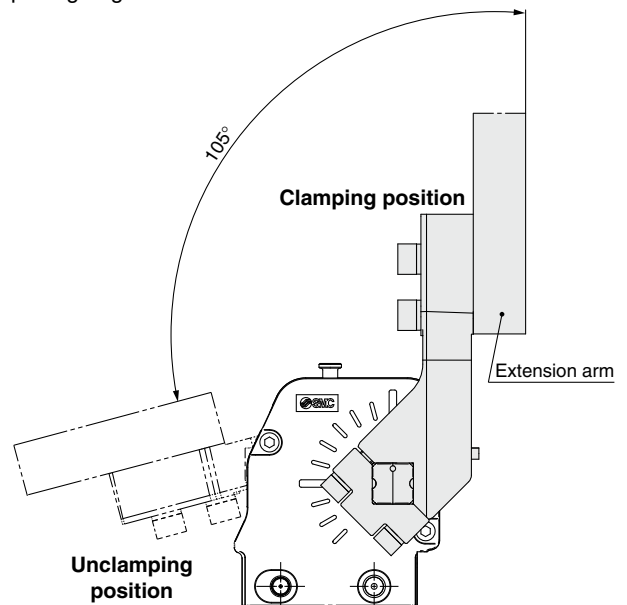

4. Proximity switch output

The switch output signal is output near the clamping end and the unclamping end respectively. The switch output signal on the clamping side does not output the status where the power clamp cylinder is locked by the toggle mechanism.

5. Operating time and allowable load mass

If the operating time is short or a load exceeding the allowable load mass is applied, a failure of the product, such as breakage and deformation, may occur. If load mass or operating speed exceed the specifications, install external buffers, such as shock absorbers.

Safety Instructions

These safety instructions are intended to prevent hazardous situations and/or equipment damage. These instructions indicate the level of potential hazard with the labels of “**Caution**,” “**Warning**” or “**Danger**.” They are all important notes for safety and must be followed in addition to International Standards (ISO/IEC)*1), and other safety regulations.

 **Caution:** **Caution** indicates a hazard with a low level of risk which, if not avoided, could result in minor or moderate injury.

 **Warning:** **Warning** indicates a hazard with a medium level of risk which, if not avoided, could result in death or serious injury.

 **Danger :** **Danger** indicates a hazard with a high level of risk which, if not avoided, will result in death or serious injury.

*1) ISO 4414: Pneumatic fluid power – General rules relating to systems.
ISO 4413: Hydraulic fluid power – General rules relating to systems.
IEC 60204-1: Safety of machinery – Electrical equipment of machines.
(Part 1: General requirements)
ISO 10218-1: Manipulating industrial robots – Safety.
etc.

Warning

1. The compatibility of the product is the responsibility of the person who designs the equipment or decides its specifications.

Since the product specified here is used under various operating conditions, its compatibility with specific equipment must be decided by the person who designs the equipment or decides its specifications based on necessary analysis and test results. The expected performance and safety assurance of the equipment will be the responsibility of the person who has determined its compatibility with the product. This person should also continuously review all specifications of the product referring to its latest catalog information, with a view to giving due consideration to any possibility of equipment failure when configuring the equipment.

2. Only personnel with appropriate training should operate machinery and equipment.

The product specified here may become unsafe if handled incorrectly. The assembly, operation and maintenance of machines or equipment including our products must be performed by an operator who is appropriately trained and experienced.

3. Do not service or attempt to remove product and machinery/equipment until safety is confirmed.

1. The inspection and maintenance of machinery/equipment should only be performed after measures to prevent falling or runaway of the driven objects have been confirmed.
2. When the product is to be removed, confirm that the safety measures as mentioned above are implemented and the power from any appropriate source is cut, and read and understand the specific product precautions of all relevant products carefully.
3. Before machinery/equipment is restarted, take measures to prevent unexpected operation and malfunction.

4. Contact SMC beforehand and take special consideration of safety measures if the product is to be used in any of the following conditions.

1. Conditions and environments outside of the given specifications, or use outdoors or in a place exposed to direct sunlight.
2. Installation on equipment in conjunction with atomic energy, railways, air navigation, space, shipping, vehicles, military, medical treatment, combustion and recreation, or equipment in contact with food and beverages, emergency stop circuits, clutch and brake circuits in press applications, safety equipment or other applications unsuitable for the standard specifications described in the product catalog.
3. An application which could have negative effects on people, property, or animals requiring special safety analysis.
4. Use in an interlock circuit, which requires the provision of double interlock for possible failure by using a mechanical protective function, and periodical checks to confirm proper operation.

Caution

1. The product is provided for use in manufacturing industries.

The product herein described is basically provided for peaceful use in manufacturing industries.
If considering using the product in other industries, consult SMC beforehand and exchange specifications or a contract if necessary.
If anything is unclear, contact your nearest sales branch.

Limited warranty and Disclaimer/ Compliance Requirements

The product used is subject to the following “Limited warranty and Disclaimer” and “Compliance Requirements”.

Read and accept them before using the product.

Limited warranty and Disclaimer

1. The warranty period of the product is 1 year in service or 1.5 years after the product is delivered, whichever is first.*2)
Also, the product may have specified durability, running distance or replacement parts. Please consult your nearest sales branch.
2. For any failure or damage reported within the warranty period which is clearly our responsibility, a replacement product or necessary parts will be provided.
This limited warranty applies only to our product independently, and not to any other damage incurred due to the failure of the product.
3. Prior to using SMC products, please read and understand the warranty terms and disclaimers noted in the specified catalog for the particular products.

*2) Vacuum pads are excluded from this 1 year warranty.

A vacuum pad is a consumable part, so it is warranted for a year after it is delivered.
Also, even within the warranty period, the wear of a product due to the use of the vacuum pad or failure due to the deterioration of rubber material are not covered by the limited warranty.

Compliance Requirements

1. The use of SMC products with production equipment for the manufacture of weapons of mass destruction (WMD) or any other weapon is strictly prohibited.
2. The exports of SMC products or technology from one country to another are governed by the relevant security laws and regulations of the countries involved in the transaction. Prior to the shipment of a SMC product to another country, assure that all local rules governing that export are known and followed.

Caution

SMC products are not intended for use as instruments for legal metrology.

Measurement instruments that SMC manufactures or sells have not been qualified by type approval tests relevant to the metrology (measurement) laws of each country. Therefore, SMC products cannot be used for business or certification ordained by the metrology (measurement) laws of each country.

 **Safety Instructions** Be sure to read the “Handling Precautions for SMC Products” (M-E03-3) and “Operation Manual” before use.

SMC Corporation

Akihabara UDX 15F,
4-14-1, Sotokanda, Chiyoda-ku, Tokyo 101-0021, JAPAN
Phone: 03-5207-8249 Fax: 03-5298-5362
<https://www.smcworld.com>
© 2022 SMC Corporation All Rights Reserved

Specifications are subject to change without prior notice and any obligation on the part of the manufacturer.

D-G