

## Modular Connection Type

# Membrane Air Dryer

**New**  
RoHS

Compatible with various ISO water quality classes

p. 18

	Outlet air flow rate [L/min (ANR)]		
IDG20-D	Up to 40	40 to 100	100 to 120
	ISO water quality class 3	ISO water quality class 3 or 4	ISO water quality class 5 or 6
IDG30-D	Up to 150	150 to 250	250 to 300
	ISO water quality class 3	ISO water quality class 4	ISO water quality class 5
IDG40-D	Up to 200	200 to 500	500 to 600
	ISO water quality class 3	ISO water quality class 4	ISO water quality class 5

\* Indicates the outlet pressure dew point for the outlet air flow rate when the inlet air pressure dew point is 25°C and the inlet air pressure is 0.7 MPa.

Modular connection is possible.

p. 12



Possible to easily supply dry air using the hollow fiber membrane!

Non-fluorocarbon

Power supply not required

No vibration or heat discharge

Variations

Size	Port size				Outlet air flow rate L/min (ANR)	Applicable modular type Air combination
	1/8	1/4	3/8	1/2		
20	●	●			100	AC20 Series
30		●	●		250	AC30 Series
40		●	●	●	500	AC40 Series

**IDG-D Series**

**SMC**  
CAT.ES30-23A

## Contributes to energy saving

### Pressure drop

Reduced by up to **61%**<sup>\*1</sup>



### Pressure drop/Outlet air flow rate

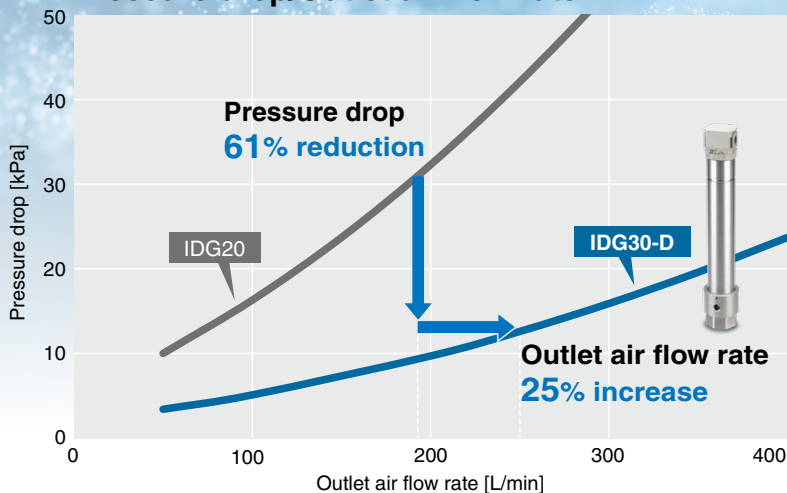

\*1 Comparison based on: IDG30-D: 12.6 kPa ← IDG20: 32.3 kPa

\*2 Comparison based on: IDG30-D: 250 L/min (ANR) ← IDG20: 200 L/min (ANR)

### Purge ratio

Series	Purge ratio	
	15%	20%
IDG20-D	14.4%	5.6% reduction
IDG5 series		
IDG30-D	14.2%	5.8% reduction
IDG20 series		
IDG40-D	14.1%	0.9% reduction
IDG50A series		

\*3 Standard performance (Purge ratio = (Purge flow rate/ Inlet air flow rate) x 100 [%])

### Outlet air flow rate

Max. **25%**<sup>\*2</sup> increase

### Purge ratio

Approx. **14%**<sup>\*3</sup>

## Simplified membrane module replacement



Easy two steps



## Changeable purge air discharge direction

Allows the purge air discharge direction to be freely changed.

The purge air port can be rotated 360° in any desired direction.

\* Refer to the Operation Manual for details on how to change.

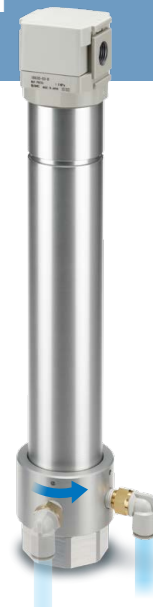

## Simple Specials System

A system designed to respond quickly and easily to your special ordering needs

For modular connection units (shipped assembled), the simple specials system can be used.



### Short lead times

This system enables us to respond to your special needs (additional machining, accessory assembly, or the designing of a modular unit) and deliver your personalized products as quickly as standard products.

### Repeat orders

Once we receive a simple special part number from one of your previous orders, we will process the order, manufacture the product, and deliver it to you as quickly as possible

Please contact your local sales representative for more details.

## CONTENTS

### Modular Connection Type Membrane Air Dryer IDG-D Series



How to Order .....	p. 3
Basic Specifications .....	p. 4
Standard Performance .....	p. 4
Outlet Dew Point Performance Graph .....	p. 5
Flow Rate Characteristics .....	p. 7
Components and Replaceable Parts .....	p. 8
Dimensions .....	p. 9
Model Selection .....	p. 11
Modular Connection Example .....	p. 12
Accessories Sold Separately .....	p. 13
International Standard ISO 8573-1:2010 .....	p. 18
Specific Product Precautions .....	p. 19

# Membrane Air Dryer

## IDG-D Series



### How to Order

IDG **30** - **03** - **D**

① ② ③ ④ ⑤

· Option/Semi-standard: Select one each for a to c.  
 · Option/Semi-standard symbol: When more than one specification is required, indicate in alphanumeric order.  
 Example) IDG30-N03B-RZ-D

	Symbol	Description	①			
			Body size			
			20	30	40	
② Thread type	Nil	Rc	●	●	●	
	N	NPT	●	●	●	
	F	G	●	●	●	
+						
③ Port size	01	1/8	●	—	—	
	02	1/4	●	●	●	
	03	3/8	—	●	●	
	04	1/2	—	—	●	
+						
④ Option	Nil	Without mounting option	●	●	●	
	B*1	With bracket	●	●	●	
+						
⑤ Semi-standard	a Purge port fitting	Nil	Without One-touch fitting	●	●	●
		P*2	With One-touch fitting	●	●	●
	+					
	b Flow direction	Nil	Flow direction: Left to right	●	●	●
		R	Flow direction: Right to left	●	●	●
	+					
c Unit	Nil	Product label in SI units: MPa	●	●	●	
	Z*3	Product label in imperial units: psi	●	●	●	

- \*1 A bracket is not assembled.  
Two screws are provided as accessories for mounting a bracket to the product. It is not permitted to install both a spacer with bracket and a spacer for modular connection at the same time.
- \*2 A One-touch fitting for the purge port is supplied with the product but is not mounted.
- \*3 For pipe thread type: NPT  
This product is for overseas use only according to the new Measurement Act. (The SI unit type is provided for use in Japan.)

**Membrane Air Dryer IDG-D Series**

**Basic Specifications**

Model		IDG20-D	IDG30-D	IDG40-D
Range of operating conditions	Fluid	Air		
	Ambient and fluid temperatures	°C -5 to 50 (No freezing)		
	Proof pressure	MPa 1.5		
	Max. operating pressure	MPa 1.0		
	Min. operating pressure	MPa 0.3		
Compressed air purity class*1		ISO8573-1: 2010 [1: 3: 2]*2		
Port size		1/8, 1/4	1/4, 3/8	1/4, 3/8, 1/2
Weight		kg 0.54	0.94	1.31

\*1 The compressed air purity class is indicated based on ISO 8573-1:2010 Compressed air – Part 1: Contaminants and purity classes.

\*2 The compressed air quality class on the inlet side is [ 1 : 4 : 2 ].

**Standard Performance**

Model		IDG20-D	IDG30-D	IDG40-D
Standard performance ①	Pressure dew point*3, *4 Inlet/Outlet	°C 25/3		
	Inlet air flow rate	L/min (ANR) 117	291	582
	Outlet air flow rate	L/min (ANR) 100	250	500
	Purge air flow rate	L/min (ANR) 16.8	41.3	82
	Inlet air pressure	MPa 0.7		
Inlet air temperature		°C 25		
Standard performance ②	Pressure dew point*3, *4 Inlet	°C 10*5		
	Pressure dew point*3, *4 Outlet	°C -9      -9      -6		
	Purity class*6 Inlet/Outlet	ISO8573-1: 2010 [1: 6: 2]*5/ISO8573-1: 2010 [1: 4: 2]		
	Inlet air flow rate	L/min (ANR) 117	291	582
	Outlet air flow rate	L/min (ANR) 100	250	500
	Purge air flow rate	L/min (ANR) 16.8	41.3	82
	Inlet air pressure	MPa 0.7		
Inlet air temperature		°C 25		

\*3 At air pressure of 0.7 MPa

\*4 Based on conditions in which the inlet air pressure, air temperature, dew point, and outlet air flow rate are all stable

\*5 Based on the use of a refrigerated air dryer

\*6 The compressed air purity class is indicated based on ISO 8573-1:2010 Compressed air – Part 1: Contaminants and purity classes.

# IDG-D Series

## Outlet Dew Point Performance Graph

Standard Performance ① (At an inlet pressure dew point of 25°C)

### Pressure Dew Point

#### IDG20-D

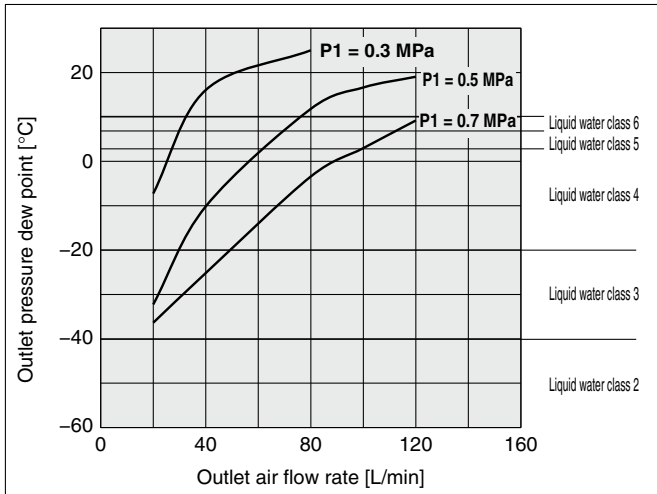

### Air Atmospheric Pressure Dew Point

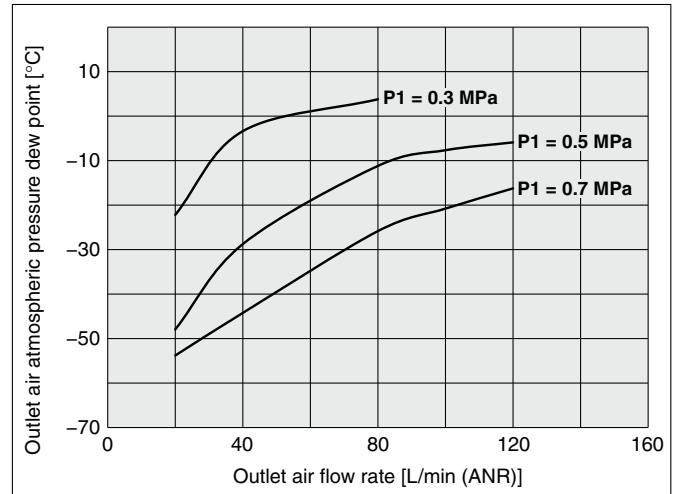

#### IDG30-D

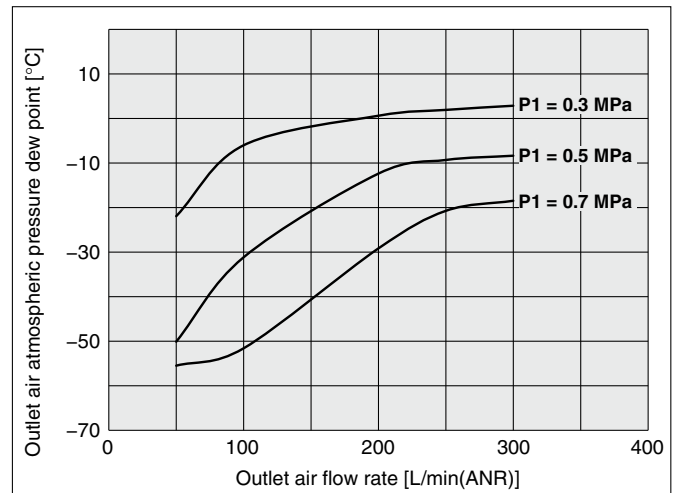
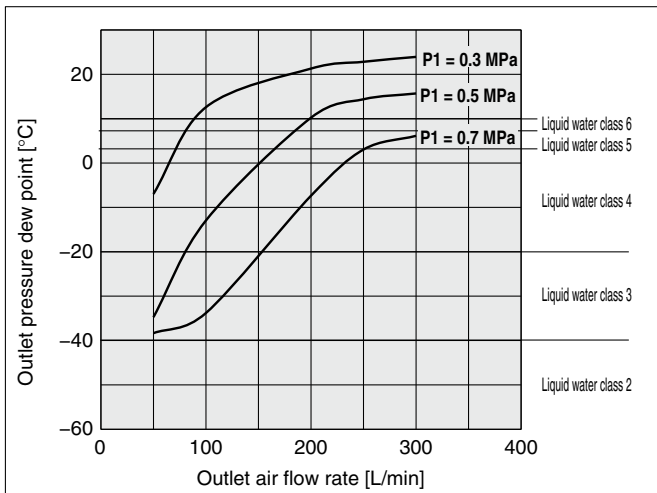

#### IDG40-D

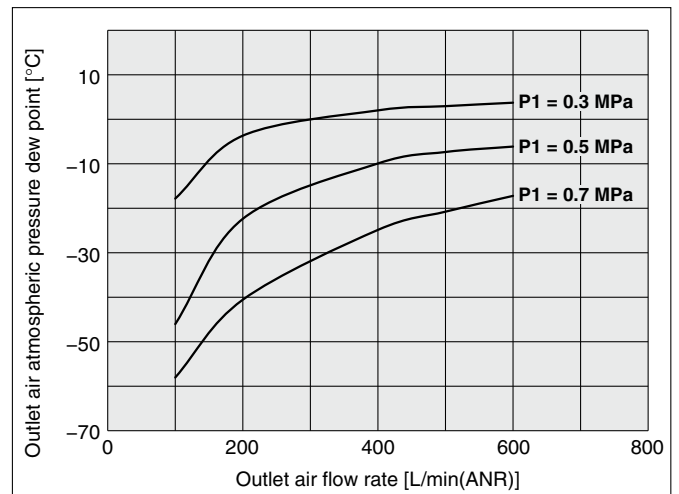
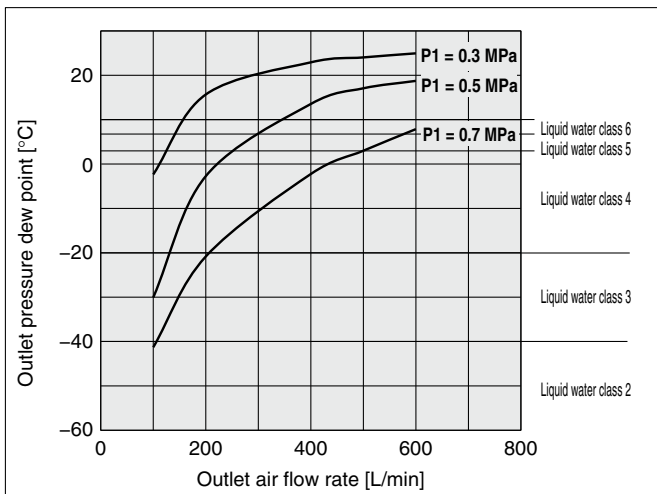

**Outlet Dew Point Performance Graph**

Standard Performance ② (At an inlet pressure dew point of 10°C)

**Pressure Dew Point**

**IDG20-D**

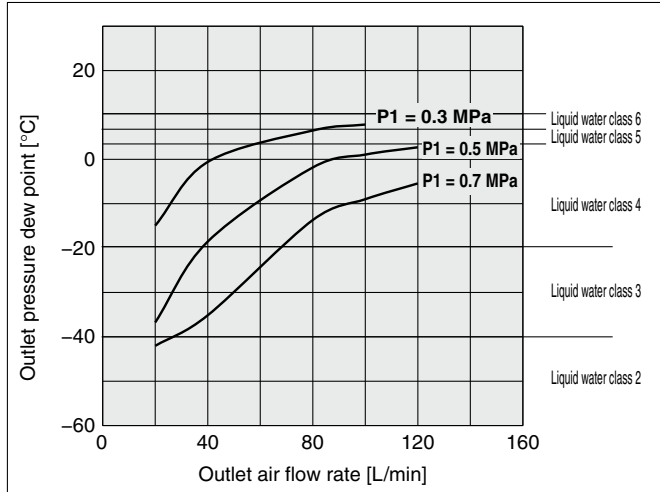

**Air Atmospheric Pressure Dew Point**

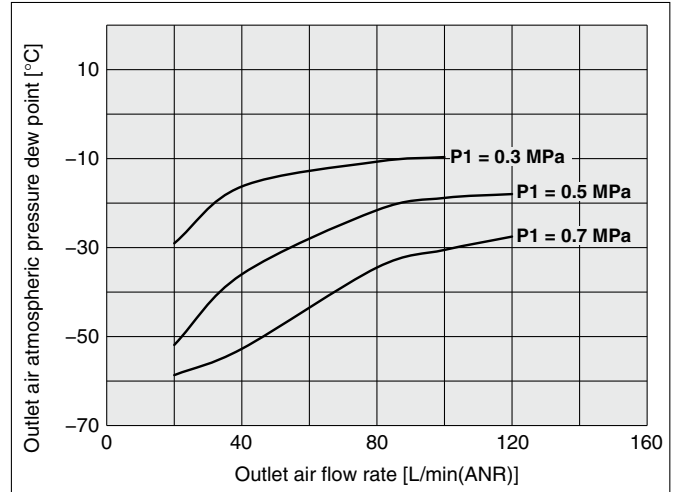

**IDG30-D**

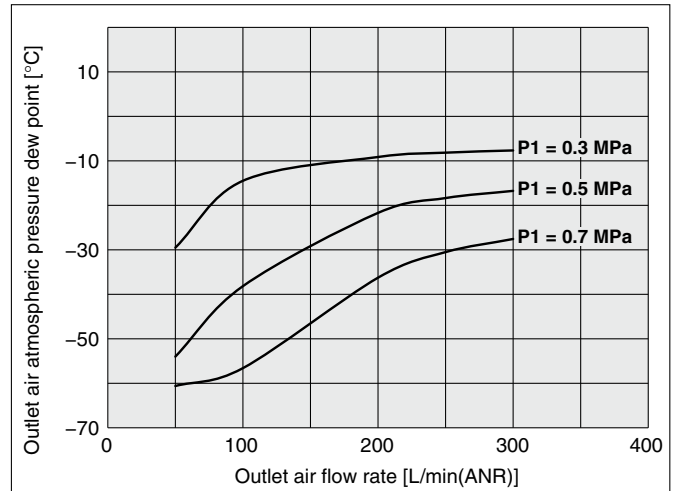
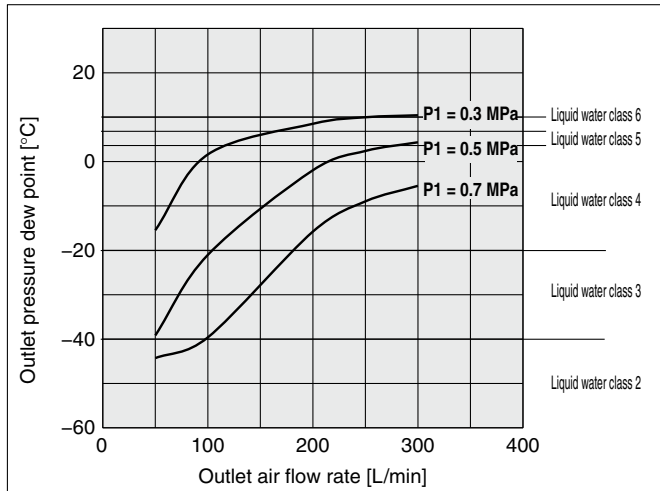

**IDG40-D**

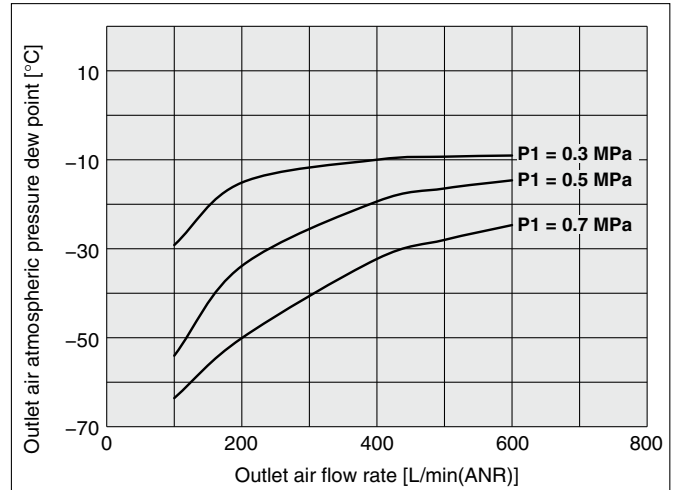
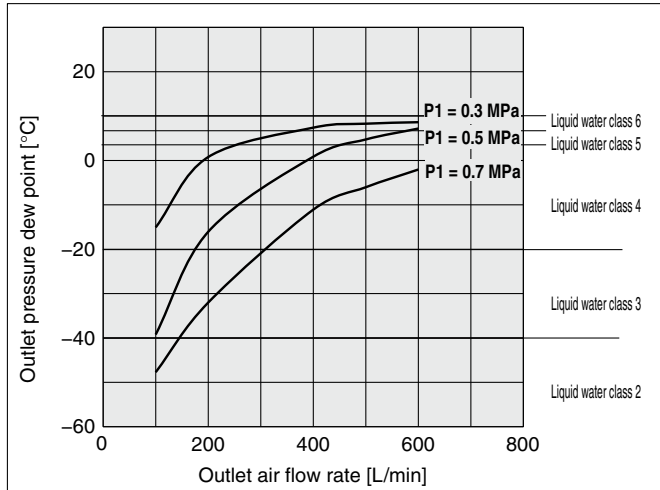

# IDG-D Series

## Flow Rate Characteristics

### IDG20-D

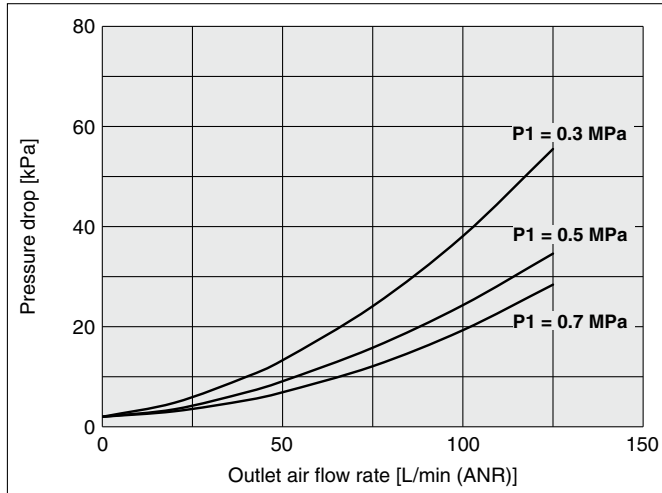

### IDG30-D

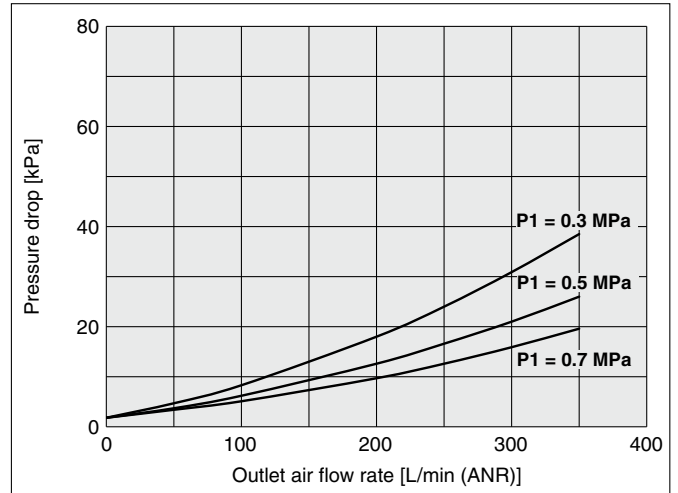

### IDG40-D

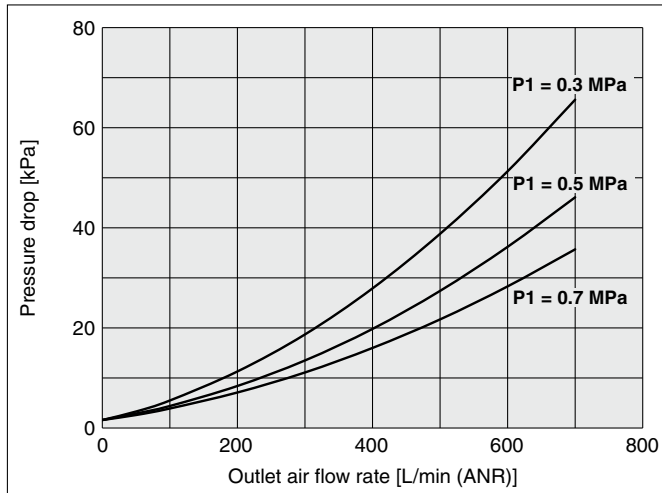

## Purge air flow rate characteristics

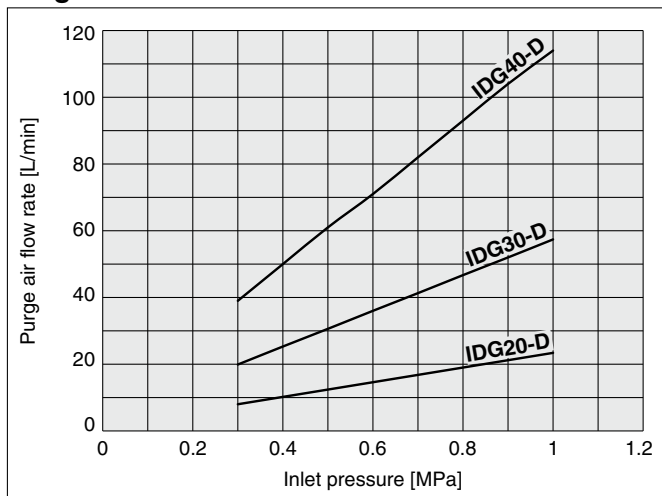



## Components and Replaceable Parts

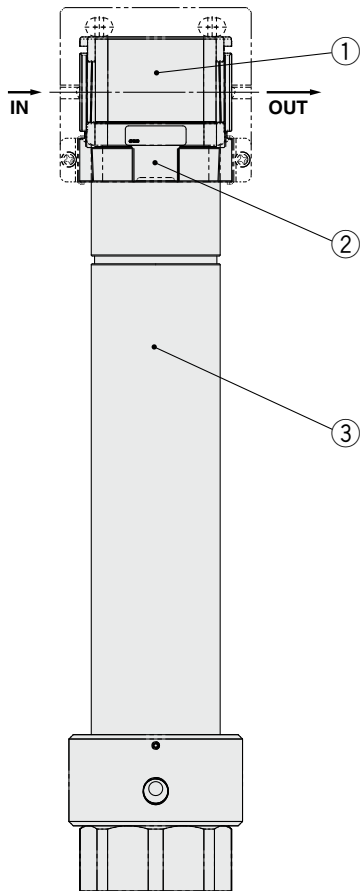

### Component Parts

No.	Description	Material
1	Body cover	Resin
2	Body	Aluminum die-cast

### Replacement Parts

No.	Description	Part number		
		IDG20-D	IDG30-D	IDG40-D
3	Membrane module kit	IDG-EL20-D	IDG-EL30-D	IDG-EL40-D

### Option/Part Nos.

Description	Part number		
	IDG20-D	IDG30-D	IDG40-D
Bracket assembly	AF24P-070AS	AF34P-070AS	AF44P-070AS

\* The assembly consists of an A and B bracket and 2 mounting screws.

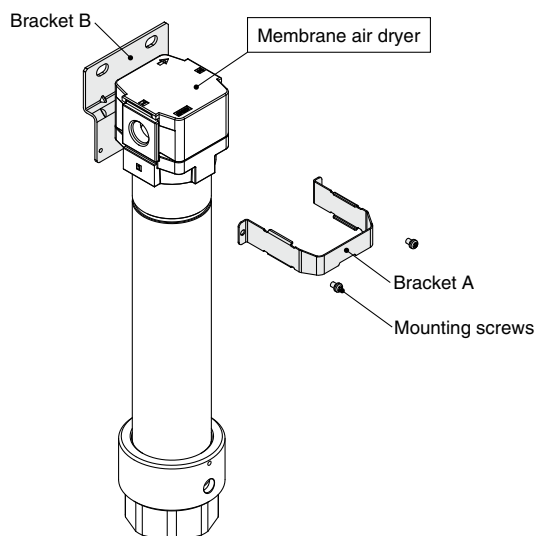

# IDG-D Series

## Dimensions

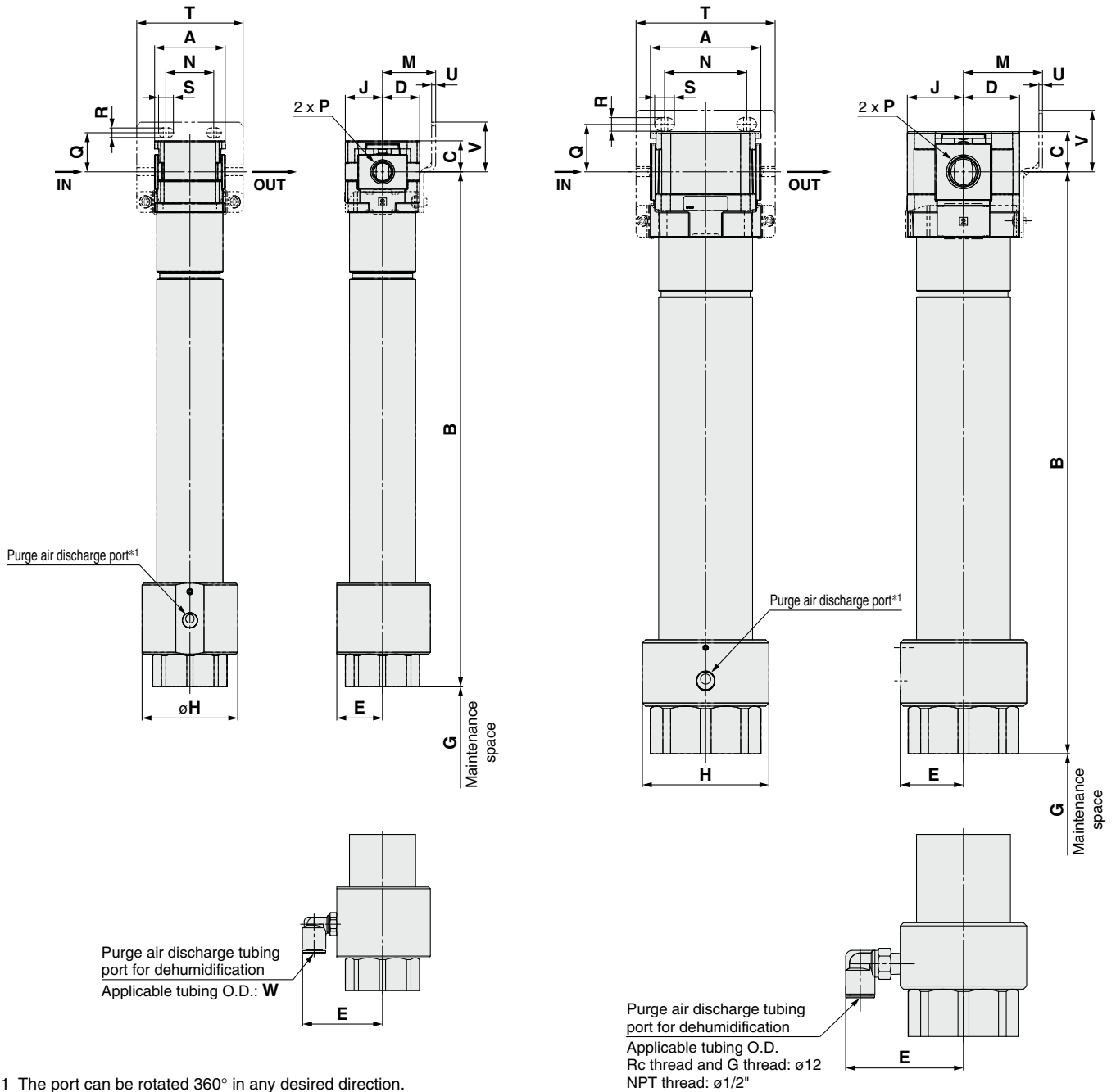

\*1 The port can be rotated 360° in any desired direction.

Model	Standard specifications									
	P	A	B	C	D	E	G	H	J	
IDG20-D	1/8, 1/4	40	290.7	17.5	21	25.8	40	54	21	
IDG30-D	1/4, 3/8	53	349.8	21.5	26.5	32.5	40	65	26.5	
IDG40-D	1/4, 3/8, 1/2	70	368	25.5	35.5	40	40	80	35.5	

Model	Optional specifications											
	Bracket mount								With fitting for purge air discharge			Note
	M	N	Q	R	S	T	U	V	E	W		
IDG20-D	30	27	22	5.4	8.4	60	2.3	28	45.2	ø8	Thread type Rc, G	
										ø5/16"	Thread type NPT	
IDG30-D	41	35	25	6.5	13	71	2.3	32	64.4	ø10	Thread type Rc, G	
										64	ø3/8"	Thread type NPT
IDG40-D	50	52	30	8.5	12.5	88	2.3	39	74.5	ø12	Thread type Rc, G	
										75.3	ø1/2"	Thread type NPT



# IDG-D Series Model Selection

Select a suitable product following the steps outlined below. Please note that the inlet air pressure and temperature have a significant impact on the outlet air dew point. If your operating conditions differ from the standard performance conditions, you must adjust values using a correction factor.

## Step 1 Establish the operating conditions.

### [Example of operating conditions]

Outlet air flow rate $Q_2$ [L/min]	120 [L/min]
Outlet air pressure dew point $T_{pdp2}$ [°C]*1	-20 [°C]
Inlet air pressure $P_1$ [MPa]	0.4 [MPa]
Inlet air pressure dew point $T_{pdp1}$ [°C]	15 [°C]
Compressed air supply capacity $Q$ [L/min]	200 [L/min]

\*1 When a conversion from atmospheric dew point to pressure dew point is necessary, use the calculation software in the SMC website.

## Step 2 Find correction factors for the inlet air pressure and inlet air pressure dew point\*2 (inlet air temperature) from the table below and calculate the corrected outlet air flow rate $Q'$ .

$$\text{Corrected outlet air flow rate } Q' = \text{Outlet air flow rate } Q_2 \div (\text{Correction factor } \textcircled{A} \times \textcircled{B})$$

\*2 Determine a correction factor from the inlet air temperature when the inlet air pressure dew point is unknown.

### Ⓐ Inlet air pressure

Inlet air pressure [MPa]	Pressure correction factor
0.3	0.47
0.4	0.70
0.5	1.00
0.6	1.30
0.7	1.69
0.8	2.15
0.9	2.60
1.0	3.15

### Ⓑ Inlet air pressure dew point

Inlet air pressure dew point (Inlet air temperature) [°C]	Temperature correction factor
3	1.64
7	1.50
15	1.26
20	1.12
25	1.00
30	0.90
35	0.80
40	0.71
45	0.63
50	0.56

### [Calculation example with the above operating conditions]

Corrected outlet air flow rate  $Q' = 120 \text{ [L/min]} \div (0.70 \times 1.26) \approx 136 \text{ [L/min]}$

## Step 3 Based on the corrected outlet air flow rate $Q'$ calculated in Step 2, find the outlet air pressure dew point $T_{pdp}'$ from the performance graph shown below and select a model that satisfies the outlet air pressure dew point $T_{pdp2}$ of the operating conditions. (The model is described on the upper left of the graph)

\* When all models are  $T_{pdp}' \geq T_{pdp2}$ , re-examine the operating conditions of Step 1.

### [Example with the above operating conditions]

As a result of the selection based on the corrected outlet air flow rate, IDG40-D meets the requirement of an outlet pressure dew point -20°C or less (refer to the dotted arrow in the performance graph below).

## Step 4 Check the purge air flow rate of the model selected in Step 3 using the purge air flow rate graph shown below.

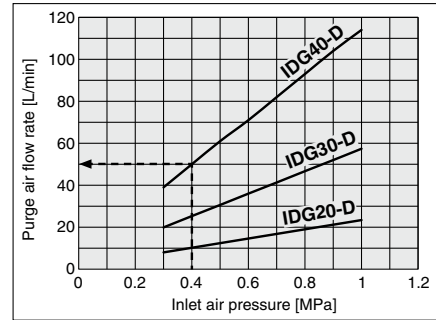

### [Example of operating conditions]

Inlet air pressure  $P_1 = 0.4$  [MPa]  
Selected model IDG40-D

From above, the purge air flow rate is 50 [L/min] (refer to the dotted arrow of the purge air flow rate graph shown above)

## Step 5 Calculate the inlet air flow rate $Q_1$ and check the compressed air supply requirement.

$$\text{Inlet air flow rate } Q_1 = \text{Outlet air flow rate } Q_2 + \text{Purge air flow rate}$$

$$\text{Compressed air supply capacity } Q \geq \text{Inlet air flow rate } Q_1$$

**YES** → Step 6    **NO** → Re-examine the operating conditions of Step 1

### [Example of operating conditions]

Inlet air flow rate  $Q_1 = 120 \text{ [L/min]} + 50 \text{ [L/min]} = 170 \text{ [L/min]}$   
Compressed air supply capacity  $Q = 200 \text{ [L/min]}$

$Q \geq Q_1$ ; proceed to Step 6

## Step 6 Choose accessories and semi-standard specifications, if required.

### [Examples of accessories and semi-standard specifications]

Accessory ...With bracket

Semi-standard ...With fitting for purge air discharge

**Model selected**

Determine the final model, referring to How to Order.

[Example with the above operating conditions and the accessory and semi-standard specification selected in Step 6]

**IDG40-04B-P-D**

## Outlet Dew Point Performance Graph

### IDG20-D

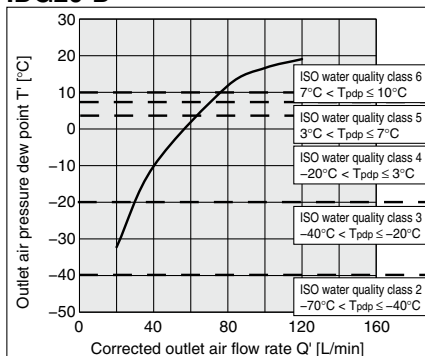

### IDG30-D

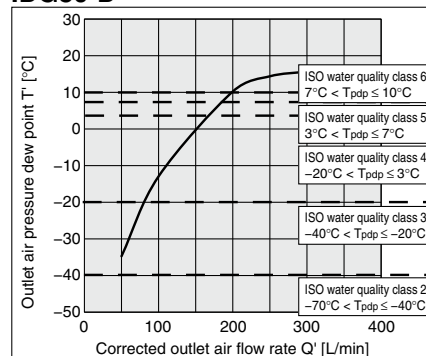

### IDG40-D

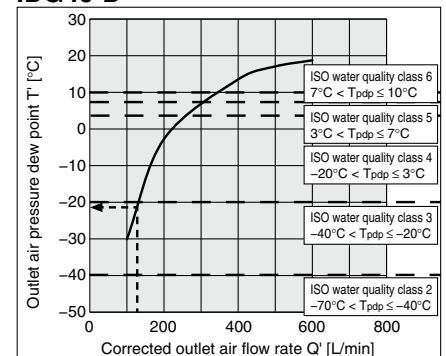

# IDG-D Series

## Modular Connection Example (Dimensions)

Products do not come assembled. They should be ordered separately and assembled by the customer. Use a spacer with a bracket when connecting modular units.

For modular connection units (shipped assembled), the simple specials system can be used. For details, refer to page 2.

### Combination example

- Mist Separator AM40-04-D ————— 1 pc.
- Micro Mist Separator AMD40-04-D ————— 1 pc.
- Membrane Air Dryer IDG40-04-D ————— 1 pc.
- Activated Carbon Filter AMK40-04-D ————— 1 pc.
- Regulator AR40-04-D ————— 1 pc.
- Spacer with Bracket Y400T-D ————— 4 pcs.

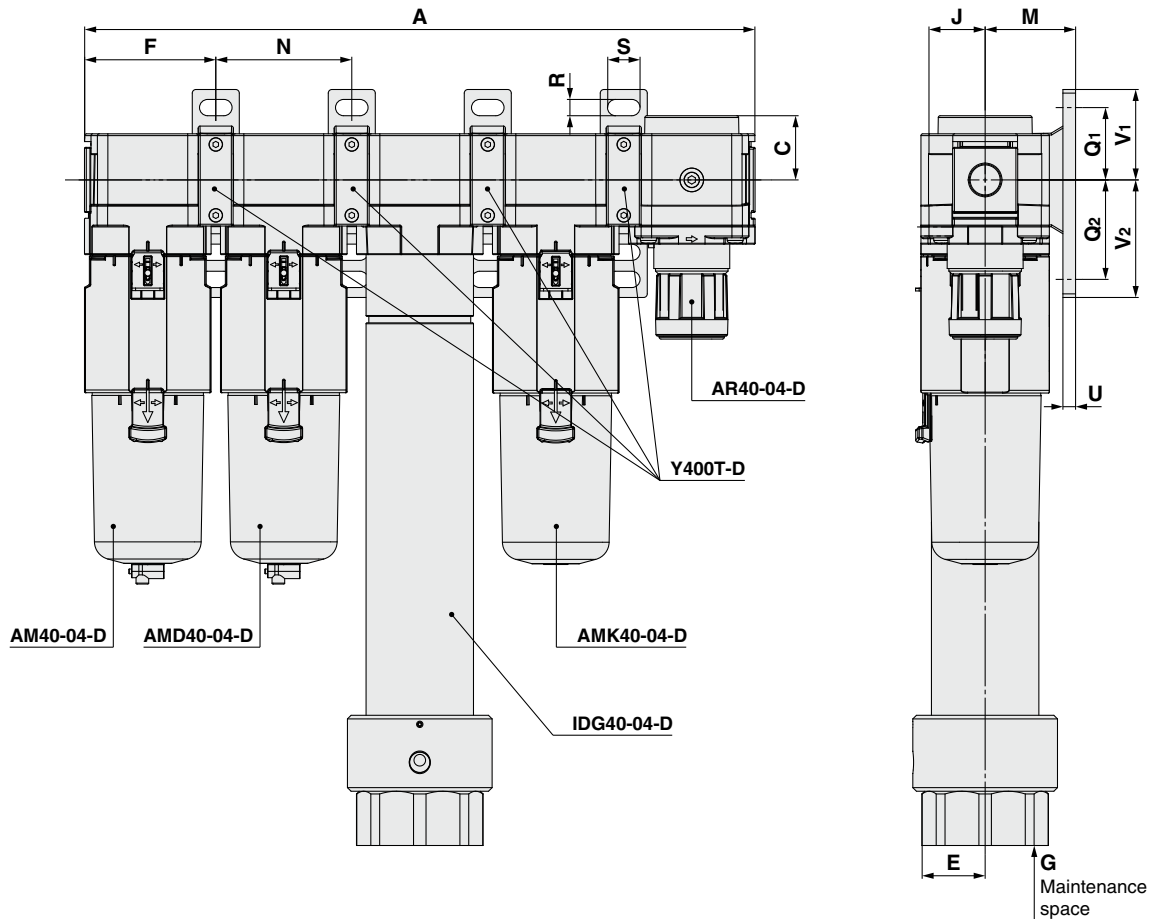

Model	Number of components	Standard specifications							Optional specifications								
		P	A	C	E	F	G	J	M	N	Q1	Q2	R	S	U	V1	V2
IDG20-D	5	1/8, 1/4	212.8	26.5	25.8	41.6	40	21	30	43.2	24	33	5.5	11.5	3.5	29	38
IDG30-D	5	1/4, 3/8	281.8	30.5	32.5	55.1	40	26.5	41	57.2	35	33	7	14	6	42.5	42.5
IDG40-D	5	1/4, 3/8, 1/2	370.8	35.5	40	72.6	40	35.5	50	75.2	40	55	9	18	7	50	65

# IDG-D Series

## Accessories Sold Separately (for Individual Parts)

### Line Filter (AFF)/Mist Separator (AM)/Micro Mist Separator (AMD)

#### How to Order

**AFF** **30** - **03** **BD** - **D**

①      ②      ③      ④      ⑤      ⑥

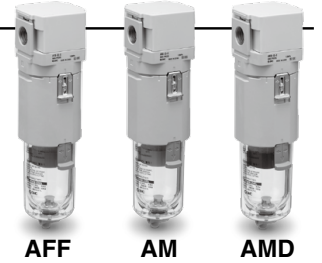

· Option/Semi-standard: Select one each for a to g.  
 · Option/Semi-standard symbol: When more than one specification is required, indicate in alphanumeric order.  
 Example) AM30-N03BD-6RZ-D

		Symbol	Description	②			
				Body size			
				20	30	40	
①	Filter type	AFF	Nominal filtration rating: 1 μm	●	●	●	
			Water droplet removal ratio: 99%	●	●	●	
		AM	Nominal filtration rating: 0.1 μm	●	●	●	
			Oil mist concentration on the outlet side: 1 mg/m <sup>3</sup>	●	●	●	
AMD	Nominal filtration rating: 0.01 μm	●	●	●			
	Oil mist concentration on the outlet side: 0.1 mg/m <sup>3</sup>	●	●	●			
③	Thread type	+					
		Nil	Rc	●	●	●	
		N* <sup>1</sup>	NPT	●	●	●	
④	Port size	F* <sup>2</sup>	G	●	●	●	
		+					
		01	1/8	●	—	—	
		02	1/4	●	●	●	
		03	3/8	—	●	●	
		04	1/2	—	—	●	
⑤	a	Mounting	06	3/4	—	—	
			10	1	—	—	—
	b	Float type auto drain	+				
			Nil	Without mounting option	●	●	●
			B* <sup>3</sup>	With bracket	●	●	●
c	Bowl* <sup>6</sup>	Nil	Without auto drain	●	●	●	
		2	N.C. (Normally closed)	●	●	●	
		6	N.O. (Normally open)	—	●	●	
⑥	d	Drain port* <sup>9</sup>	C* <sup>4</sup>	Polycarbonate bowl	●	●	●
			D* <sup>5</sup>	Stainless steel bowl	—	—	—
			+				
			8	Metal bowl	●	●	●
			C	Nylon bowl	●	●	●
	e	Indicator* <sup>12</sup>	8	Metal bowl with level gauge	—	●	●
			6C	With bowl guard	●	—* <sup>7</sup>	—* <sup>7</sup>
			6C	With bowl guard (Nylon bowl)	●	—* <sup>8</sup>	—* <sup>8</sup>
	f	Flow direction	+				
			Nil	With drain cock	●	●	●
J* <sup>10</sup>			Drain guide 1/8	●	—	—	
g	Unit	W* <sup>11</sup>	Drain guide 1/4	—	●	●	
		+					
			Drain cock, Barb fitting (ø6)	—	●	●	
			Nil	Without indicator	●	●	●
			L	With element service indicator	●	●	●
			+				
			Nil	Flow direction: Left to right	●	●	●
			R	Flow direction: Right to left	●	●	●
			+				
			Nil	Name plate and caution plate for bowl in SI units: MPa, °C	●	●	●
			Z* <sup>13</sup>	Name plate and caution plate for bowl in imperial units: psi, °F	○* <sup>14</sup>	○* <sup>14</sup>	○* <sup>14</sup>

\*1 The drain guide is either NPT1/8 (applicable to the AFF20, AM20, and AMD20) or NPT1/4 (applicable to the AFF30 to AFF40, AM30 to AM40, and AMD30 to AMD40). The auto drain port comes with a ø3/8" One-touch fitting (applicable to the AFF30 to AFF40, AM30 to AM40, and AMD30 to AMD40).  
 \*2 The drain guide is either G1/8 (applicable to the AFF20, AM20, and AMD20) or G1/4 (applicable to the AFF30 to AFF40, AM30 to AM40, and AMD30 to AMD40).  
 \*3 The assembly consists of 2 types of brackets and 2 mounting screws.  
 \*4 When pressure is not applied, condensate which does not start the auto drain mechanism will be left in the bowl. Releasing the residual condensate before ending operations for the day is recommended.  
 \*5 If the compressor is small (0.75 kW, discharge flow is less than 100 L/min (ANR)), air leakage from the drain cock may occur during the start of operations. The N.C. type is recommended.

\*6 For chemical resistance of the bowl, refer to the chemical data in item 1 of "Design" precautions in "AFF/AM/AMD/AMK Series Specific Product Precautions 1."  
 \*7 A bowl guard is provided as standard equipment (polycarbonate).  
 \*8 A bowl guard is provided as standard equipment (nylon).  
 \*9 The combination of float type auto drain C and D is not available.  
 \*10 Without a valve function  
 The mounting screws are the same as the thread of ③.  
 \*11 The combination of metal bowl 2 and 8 is not available.  
 \*12 After purchase, option "Nil" (Without indicator) cannot be changed to option "L" (With element service indicator).  
 \*13 For pipe thread type: NPT. This product is for overseas use only according to the new Measurement Act. (The SI unit type is provided for use in Japan.)  
 \*14 ○: For pipe thread type: NPT only

**Dimensions**

**AFF/AM/AMD20**

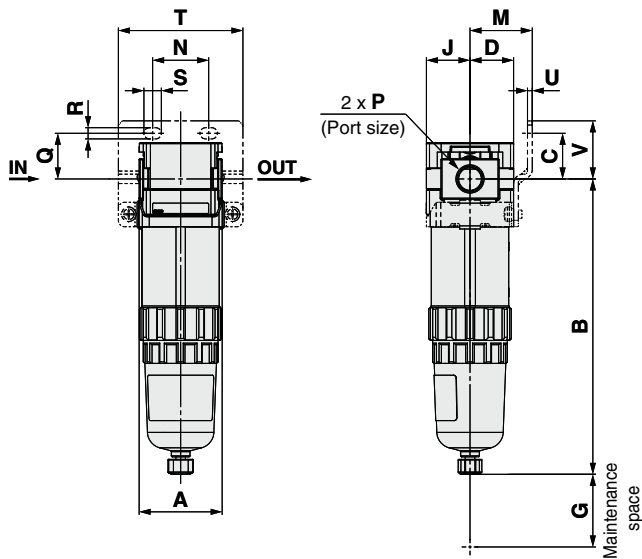

**AFF/AM/AMD30  
AFF/AM/AMD40**

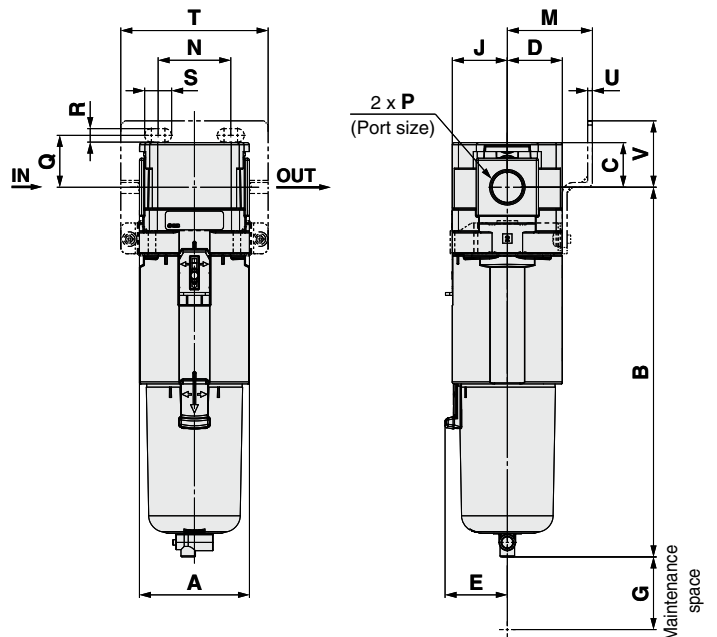

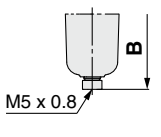
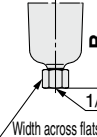
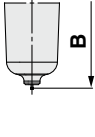
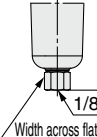
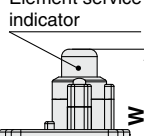
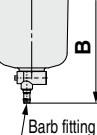
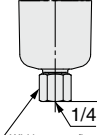
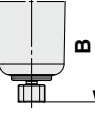
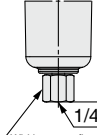
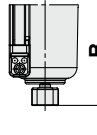
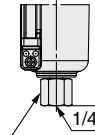
Applicable model	Optional specifications	Semi-standard						Element service indicator
		PC/PA bowl		Metal bowl		Metal bowl with level gauge		
		Drain cock with barb fitting	With drain guide	With drain cock	With drain guide	With drain cock	With drain guide	
<b>AFF/AM/AMD20</b>	 M5 x 0.8		 1/8 Width across flats 14		 1/8 Width across flats 14			 W
<b>AFF/AM/AMD30</b> <b>AFF/AM/AMD40</b>	N.O.: Black N.C.: Gray  Thread type/Rc, G: ø10 One-touch fitting Thread type/NPT: ø3/8" One-touch fitting		 1/4 Width across flats 17		 1/4 Width across flats 17		 1/4 Width across flats 17	

Model	Standard specifications																Optional specifications		
																	Bracket mount		With auto drain
	P	A	B	C	D	E	G	J	M	N	Q	R	S	T	U	V	B		
<b>AFF20-D/AM20-D/AMD20-D</b>	1/8, 1/4	40	142.3	17.5	21	—	25	21	30	27	22	5.4	8.4	60	2.3	28	159.6		
<b>AFF30-D/AM30-D/AMD30-D</b>	1/4, 3/8	53	178.1	21.5	26.5	30	35	26.5	41	35	25	6.5	13	71	2.3	32	219.8		
<b>AFF40-D/AM40-D/AMD40-D</b>	1/4, 3/8, 1/2	70	223.5	25.5	35.5	38.4	40	35.5	50	52	30	8.5	12.5	88	2.3	39	263.3		

Model	Semi-standard specifications						
	PC/PA bowl		Metal bowl		Metal bowl with level gauge		Element service indicator
	Stainless steel bowl						
	With barb fitting	With drain guide	With drain cock	With drain guide	With drain cock	With drain guide	
B	B	B	B	B	B	W	
<b>AFF20-D/AM20-D/AMD20-D</b>	—	146.1	142.1	148.6	—	—	50.6
<b>AFF30-D/AM30-D/AMD30-D</b>	186.6	184.9	180.6	185.1	200.6	205.1	54.3
<b>AFF40-D/AM40-D/AMD40-D</b>	232	230.3	225.9	230.4	245.9	250.4	58.3

# IDG-D Series

## Activated Carbon Filter (AMK)

### How to Order

**AMK** **30** - **F** **03** **B** -  - **D**

①      ②      ③      ④      ⑤      ⑥



· Option/Semi-standard: Select one each for a to d.  
 · Option/Semi-standard symbol: When more than one specification is required, indicate in alphanumeric order.  
 Example) AMK30-N03B-6RZ-D

	Symbol	Description	②						
			Body size						
			20	30	40	50	60		
①	Filter type	<b>AMK</b>	Activated carbon filter	●	●	●	●	●	
			+						
③	Thread type	<b>Nil</b>	Rc	●	●	●	●	●	
		<b>N</b>	NPT	●	●	●	●	●	
		<b>F</b>	G	●	●	●	●	●	
			+						
④	Port size	<b>01</b>	1/8	●	—	—	—	—	
		<b>02</b>	1/4	●	●	●	—	—	
		<b>03</b>	3/8	—	●	●	—	—	
		<b>04</b>	1/2	—	—	●	—	—	
		<b>06</b>	3/4	—	—	—	●	—	
		<b>10</b>	1	—	—	—	●	●	
			+						
⑤	Option a	Mounting	<b>Nil</b>	Without mounting option	●	●	●	●	●
			<b>B*1</b>	With bracket	●	●	●	●	●
			+						
⑥	Semi-standard b	Bowl*2	<b>Nil</b>	Polycarbonate bowl	●	●	●	—	—
				Stainless steel bowl	—	—	—	●	●
			<b>2</b>	Metal bowl	●	●	●	—	—
			<b>6</b>	Nylon bowl	●	●	●	—	—
			<b>C</b>	With bowl guard	●	—*3	—*3	—	—
			<b>6C</b>	With bowl guard (Nylon bowl)	●	—*4	—*4	—	—
			+						
	c	Flow direction	<b>Nil</b>	Flow direction: Left to right	●	●	●	●	●
			<b>R</b>	Flow direction: Right to left	●	●	●	●	●
			+						
	d	Pressure unit	<b>Nil</b>	Name plate and caution plate in SI units: MPa/°C	●	●	●	●	●
			<b>Z*5</b>	Name plate and caution plate in imperial units: psi/°F	○*6	○*6	○*6	○*6	○*6

\*1 The assembly consists of 2 types of brackets and 2 mounting screws.

\*2 For chemical resistance of the bowl, refer to the chemical data in item 1 of "Design" precautions in "AFF/AM/AMD/AMK Series Specific Product Precautions 1."

\*3 A bowl guard is provided as standard equipment (polycarbonate).

\*4 A bowl guard is provided as standard equipment (nylon).

\*5 For pipe thread type: NPT

This product is for overseas use only according to the new Measurement Act. (The SI unit type is provided for use in Japan.)

\*6 ○: For pipe thread type: NPT only





**Dimensions**

**AMK20**

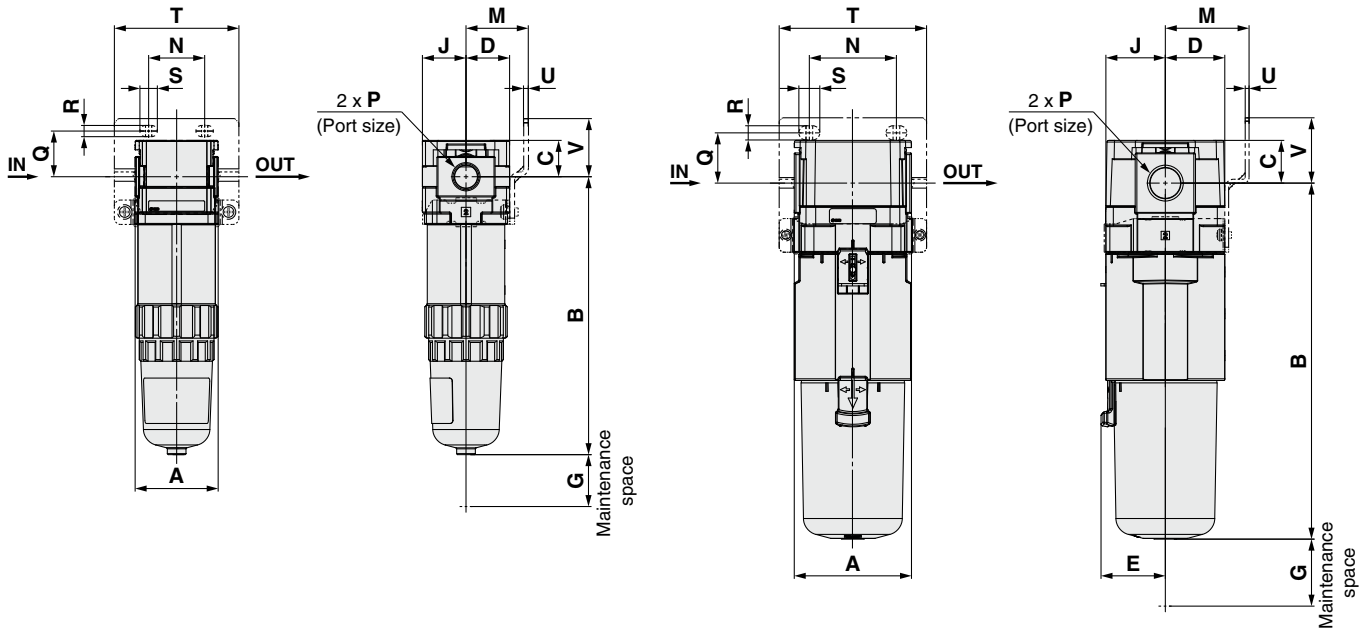
**AMK30  
AMK40**



Applicable model	Semi-standard
	Metal bowl
AMK20-D	
AMK30-D AMK40-D	

Model	Standard specifications								Optional specifications							
	P	A	B	C	D	E	G	J	Bracket mount							
									M	N	Q	R	S	T	U	V
AMK20-D	1/8, 1/4	40	133.9	17.5	21	—	25	21	30	27	22	5.4	8.4	60	2.3	28
AMK30-D	1/4, 3/8	53	167	21.5	26.5	30	35	26.5	41	35	25	6.5	13	71	2.3	32
AMK40-D	1/4, 3/8, 1/2	70	212.5	25.5	35.5	38.4	40	35.5	50	52	30	8.5	12.5	88	2.3	39

Model	Semi-standard specifications
	Metal bowl
	B
AMK20-D	139.1
AMK30-D	167
AMK40-D	212.4

# IDG-D Series

## Spacer / Spacer with Bracket

Y 300   - D

①      ②

	Symbol	Description	①		
			Body size [Applicable size]		
			200 [IDG20-D]	300 [IDG30-D]	400 [IDG40-D]
②	Bracket	Nil	●	●	●
		T	●	●	●

Spacer  
(Y□-D)



Spacer with bracket  
(Y□T-D)



### Standard Specifications

Fluid	Air
Ambient and fluid temperatures	-5 to 60°C (No freezing)
Proof pressure	1.5 MPa
Max. operating pressure	1.0 MPa

### Replacement Parts

Description	Material	Part number		
		Y200-D Y200T-D	Y300-D Y300T-D	Y400-D Y400T-D
Seal	HNBR	Y220P-050S	Y320P-050S	Y420P-050S

### Dimensions

#### Spacer

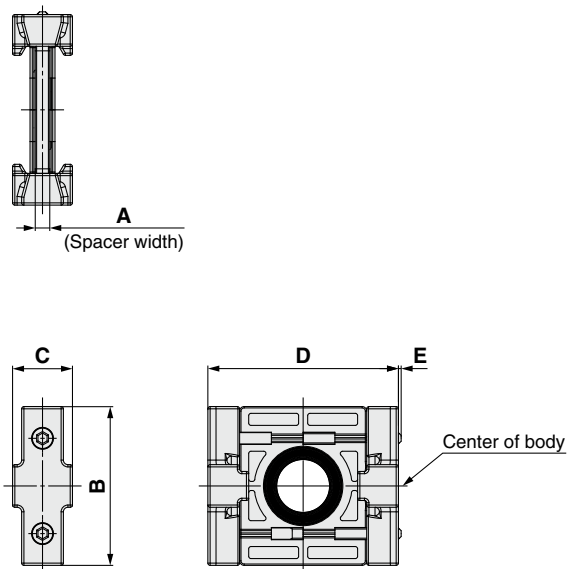

#### Spacer with bracket

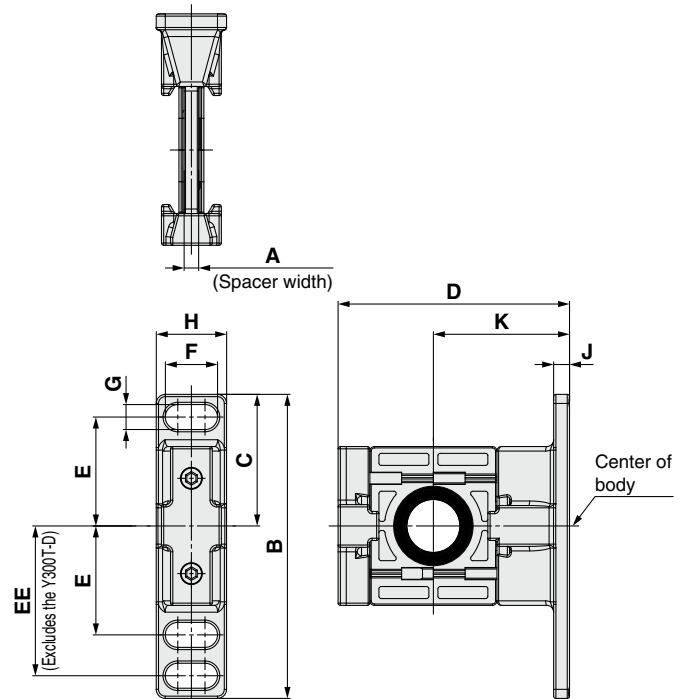

Part no.	A	B	C	D	E	Applicable model
Y200-D	3.2	35	13.2	42	0.6	IDG20-D
Y300-D	4.2	43	16.2	53	—	IDG30-D
Y400-D	5.2	51	19.2	71	—	IDG40-D

Part no.	A	B	C	D	E	EE	F	G	H	J	K	Applicable model
Y200T-D	3.2	67	29	51	24	33	11.5	5.5	15.5	3.5	30	IDG20-D
Y300T-D	4.2	85	42.5	67.5	35	—	14	7	20	6	41	IDG30-D
Y400T-D	5.2	115	50	85.5	40	55	18	9	26	7	50	IDG40-D

# International Standard ISO 8573-1:2010

## Compressed Air Purity Classes

Compressed air is used in a variety of manufacturing processes. In this age, compressed air with a high degree of purity is becoming increasingly necessary.

For this reason, it is necessary to remove contaminants from systems which supply compressed air and to secure the quality. The standard which stipulates the class according to the quantities of contaminants in compressed air is ISO 8573-1.

### [Outline]

Stipulates the purity class of contaminants (particles, water, oil) mixed in with the compressed air

### [Scope]

Can be used in various places in compressed air systems

### [Purity Classes]

Class	Particles			Humidity and liquid water		Oil	
	Maximum number of particles per cubic meter as a function of particle size d [μm]			Mass concentration Cp	Pressure dew point	Concentration of liquid water Cw	Concentration of total oil
	0.1 < d ≤ 0.5	0.5 < d ≤ 1.0	1.0 < d ≤ 5.0	[mg/m <sup>3</sup> ]	[°C]	[g/m <sup>3</sup> ]	[mg/m <sup>3</sup> ]
0	As specified by the equipment user or supplier and more stringent than class 1						
1	≤ 20000	≤ 400	≤ 10	—	≤ -70	—	≤ 0.01
2	≤ 400000	≤ 6000	≤ 100	—	≤ -40	—	≤ 0.1
3	—	≤ 90000	≤ 1000	—	≤ -20	—	≤ 1
4	—	—	≤ 10000	—	≤ +3	—	≤ 5
5	—	—	≤ 100000	—	≤ +7	—	—
6	—	—	—	0 < Cp ≤ 5	≤ +10	—	—
7	—	—	—	5 < Cp ≤ 10	—	Cw ≤ 0.5	—
8	—	—	—	—	—	0.5 < Cw ≤ 5	—
9	—	—	—	—	—	5 < Cw ≤ 10	—
x	—	—	—	Cp > 10	—	Cw > 10	> 5

### [Terms and Definitions]

- Purity class: An index assigned for each classification obtained by dividing the concentration of each contaminant into ranges
- Particle: Small discrete mass of solid or liquid matter
- Humidity and liquid water: Water vapor (gas), Water droplets
- Oil: Liquid oil, Oil mist, Oil vapor

### [Purity Class Designation Example]

# ISO 8573-1:2010 [ 4 : 6 : 2 ]

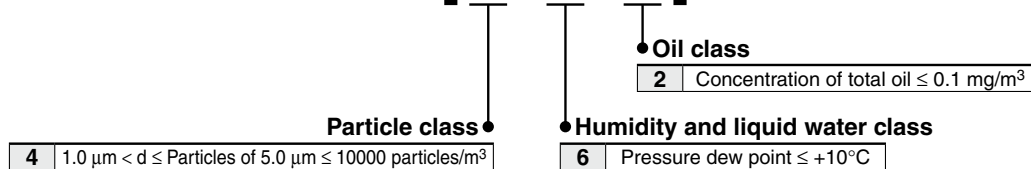

List of systems which conform to the degree of purity required for compressed air

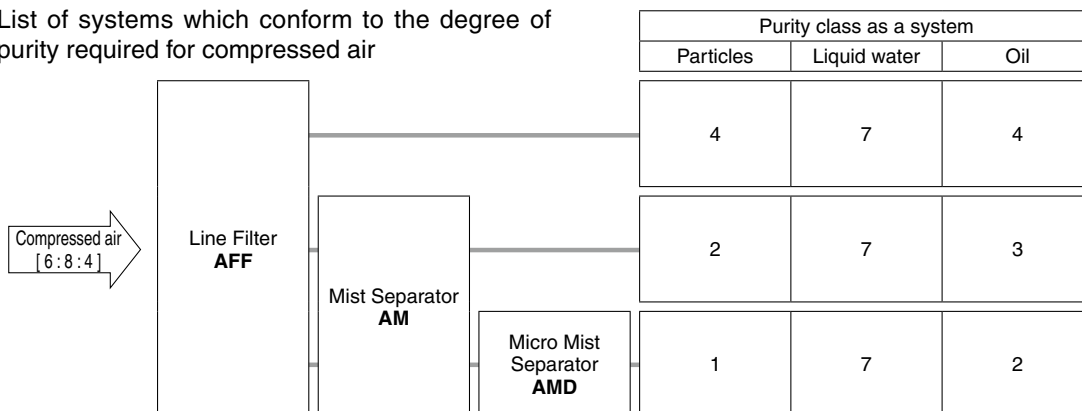

The class indicates the compressed air purity according to ISO 8573-1:2010 (JIS B 8392-1:2012) and indicates the maximum purity class which can be obtained using that system. Note, however, that this value will differ according to the inlet air conditions.



## IDG-D Series

# Specific Product Precautions 1

Be sure to read this before handling the products. Refer to the back cover for safety instructions. For air preparation equipment precautions, refer to the "Handling Precautions for SMC Products" and the "Operation Manual" on the SMC website.

### Design

## ⚠ Warning

- The oxygen content of outlet air may decrease.**  
Do not use the product to dehumidify air for breathing. Do not use only outlet air (dry air) in a closed room.
- Chemical substances including those listed in the table below may damage the membrane module. Do not use in an environment or compressed air that contains these substances.**

Category	Chemicals not to be included
<b>Solvents</b>	Acetone, benzene, phenol, toluene, trichloroethylene, xylene, cresol, thinner, aniline, chloroform, chlorobenzene, trichloroethane, ethylbenzene, ethyl alcohol, methyl alcohol, isopropyl alcohol, dioxin, tetrahydrofuran, methylene chloride, cyclohexane, carbon tetrachloride, methyl ketone, ethyl ketone, hexafluoroisopropanol, and others
<b>Acids</b>	Sulfuric acid, nitric acid, hydrochloric acid, acetic acid, lactic acid, chromic acid, and others
<b>Gases</b>	Chlorine gas, sulfurous acid gas, hydrogen chloride, bromine, ozone, ammonia, and others
<b>Oils</b>	Phosphoric-ester hydraulic oil, fuel oil, water soluble cutting oil (alkaline), kerosene, and others
<b>Strong bases</b>	Lithium hydroxide, sodium hydroxide, potassium hydroxide, calcium hydroxide, and others
<b>Others</b>	Anaerobic adhesive, anaerobic sealant, and others

- Do not exert intermittent pressure on this product. Applications in which the difference between the inlet and outlet pressure exceeds 0.1 MPa must be avoided. Failure to do so may result in product breakage.**  
Intermittent pressure damages the product.  
(Example: Frequent operation of a solenoid valve will cause large pressure fluctuations in the IDG.)
- Do not obstruct the purge air discharge ports.**  
The product may break or the dehumidifying performance may decrease when the back pressure of the purge flow path increases.

## ⚠ Caution

- The outlet dew point differs according to the inlet air pressure, inlet dew point, and outlet air flow rate.**
- Devise a layout which considers the position of purge air discharge ports.**  
As for purge air, the surrounding air may get included by discharging of air being used. Stain, corrosion, or device malfunction may be caused at the area where purging air is directly blowing due to the quality of the used air and surrounding air.
- Consider the purge air flow rate.**  
The air supply flow rate must be greater than the total of the outlet air flow rate and the purge air flow rate. Insufficient air supply will effect the dehumidifying performance.
- Piping materials for low dew point air**  
When air with a low dew point is necessary, use a circuit structure that uses metal (stainless steel, in particular) or fluororesin. When a material with high permeation of moisture (water vapor) is used (nylon, polycarbonate, polyurethane, etc.), air with a low dew point may get affected by the humidity of the surrounding environment and the dew point may increase.

### Design

## ⚠ Caution

- A certain time is required to reach the standard dew point.**  
After air is provided to the product and the inlet condition has stabilized, a certain time is required to reach the outlet dew point given in the product specifications. In addition, a longer time is necessary as the required air dew point decreases.

### Selection

## ⚠ Caution

- Select the model based on the required outlet air flow rate and dew point.**
- With fitting for purge air discharge (Semi-standard: P)**  
The dehumidification performance decreases in proportion to the length of the tube for discharging purge air because of an increase in the back pressure on the purge air port. Use a tube of the specified size and keep its length within 5 meters.
- Lines and marks may appear on the product due to the manufacturing process.**

### Mounting

## ⚠ Warning

- Handle with care.**  
Injury may occur or the product may break when dropped.
- Connect the product according to the "1"(IN) and "2"(OUT) indications or the arrows for air direction. Incorrect connection may result in a malfunction.**
- Install with adequate space for maintenance and operation. Refer to the dimensions of each part for the necessary amount of space.**

### Piping

## ⚠ Warning

- Tighten the 2 holding screws on the spacer with bracket or spacer evenly.**  
Tighten them to the recommended tightening torque. Insufficient tightening torque may result in loosening or sealing failure. Excessive tightening torque may damage the thread, etc.

### Recommended Torque

Unit: N·m

Applicable model	IDG20-D	IDG30-D	IDG40-D
Spacer with bracket part number	Y200T-D	Y300T-D	Y400T-D
Spacer part number	Y200-D	Y300-D	Y400-D
Torque	0.36 ±0.036	1.2 ±0.05	1.2 ±0.05

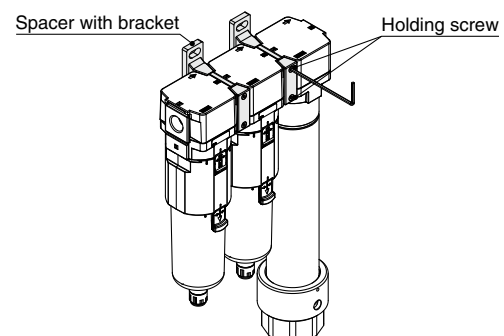



## IDG-D Series

# Specific Product Precautions 2

Be sure to read this before handling the products. Refer to the back cover for safety instructions. For air preparation equipment precautions, refer to the “Handling Precautions for SMC Products” and the “Operation Manual” on the SMC website.

### Piping

## Warning

### 2. Piping load and moment

Avoid any torsional or bending moments other than those caused by the equipment’s own weight as failure to do so may result in damage.

Support external piping separately. If moment application is unavoidable during operation, the moment should be lower than the max. moment shown below.

Piping materials without flexibility, such as steel tube piping, are prone to being affected by excess moment loads or vibrations from the piping side. Use flexible tubing in between to avoid such effects.

Unit: N·m

Applicable model	IDG20-D	IDG30-D	IDG40-D
Max. moment (M)	14.5	16	19.5

Max. moment (M) = Length (L) x Load (F)

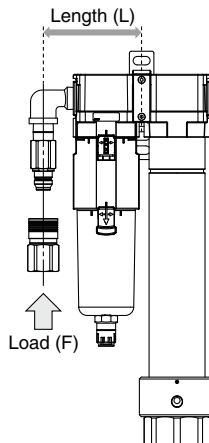

### 3. Connect piping/fittings using the recommended torque while holding the female thread side tightly.

Insufficient tightening torque can result in loose piping or sealing failure. Over tightening may break the thread. If the female side is not held while tightening, excessive force will be applied to the bracket directly, resulting in breakage.

### Recommended Tightening Torque

Unit: N·m

Connection thread	1/8	1/4	3/8	1/2	3/4	1
Torque	7 to 9	12 to 14	22 to 24	28 to 30	28 to 30	36 to 38

### 4. When an SMC One-touch fitting is used, refer to the operation manual for the One-touch fitting.

### 5. Before piping is connected, flush the piping.

Be sure to remove chips, cutting oil and other debris. If they get into the product, unexpected malfunction or damage to the product may occur.

### Air Supply

## Caution

### 1. Make sure to install a mist separator and a micro mist separator on the upstream side of the product. When there is a large quantity of dust (solid foreign matter) in the supply air, install an air filter or line filter on the upstream side of the mist separator.

The performance may deteriorate when the concentration of oil or solid foreign matter is high in the inlet air of the product.

### 2. Do not allow liquid water to enter the product.

The dehumidification performance may deteriorate, and the product may get damaged with liquid water enters the product.

### 3. Decrease the inlet air pressure dew point to lower than the ambient temperature.

The body of the membrane air dryer is at a similar temperature to the ambient temperature. When air, with a dew point higher than the ambient temperature, enters the product, it will be cooled internally, generate condensation, and lead to the entry of liquid water.

### Operating Environment

## Caution

### 1. Do not operate the product at a temperature outside the operating condition range (fluid and ambient temperature).

Resin is used for the membrane module. Operation at a temperature exceeding the operating condition range will damage the membrane module.

### 2. Do not use in the following environments, as this can cause failure.

- 1) In locations having corrosive gases, organic solvents, and chemicals, or in locations where these elements are likely to adhere to the equipment.
- 2) In locations where salt water, water, or water vapor could come in contact with the equipment.
- 3) In locations that is exposed to shocks and vibrations.

### Maintenance

## Caution

### 1. Do not remove parts or piping while pressure is applied to the product.

### 2. Ensure that the pressure of the piping and equipment is zero, before removing any parts or piping.

Performing any work while pressure remains in the equipment may lead to injury or product damage.

### 3. When replacing the membrane module

When a modular spacer is connected, be sure to remove the membrane air dryer before replacing the membrane module. Replacement without removing it may cause injury or damage to the product.

## Safety Instructions

These safety instructions are intended to prevent hazardous situations and/or equipment damage. These instructions indicate the level of potential hazard with the labels of “**Caution**,” “**Warning**” or “**Danger**.” They are all important notes for safety and must be followed in addition to International Standards (ISO/IEC)\*1), and other safety regulations.

 **Caution:** **Caution** indicates a hazard with a low level of risk which, if not avoided, could result in minor or moderate injury.

 **Warning:** **Warning** indicates a hazard with a medium level of risk which, if not avoided, could result in death or serious injury.

 **Danger:** **Danger** indicates a hazard with a high level of risk which, if not avoided, will result in death or serious injury.

\*1) ISO 4414: Pneumatic fluid power – General rules relating to systems.  
ISO 4413: Hydraulic fluid power – General rules relating to systems.  
IEC 60204-1: Safety of machinery – Electrical equipment of machines.  
(Part 1: General requirements)  
ISO 10218-1: Manipulating industrial robots – Safety.  
etc.

### Warning

#### 1. The compatibility of the product is the responsibility of the person who designs the equipment or decides its specifications.

Since the product specified here is used under various operating conditions, its compatibility with specific equipment must be decided by the person who designs the equipment or decides its specifications based on necessary analysis and test results. The expected performance and safety assurance of the equipment will be the responsibility of the person who has determined its compatibility with the product. This person should also continuously review all specifications of the product referring to its latest catalog information, with a view to giving due consideration to any possibility of equipment failure when configuring the equipment.

#### 2. Only personnel with appropriate training should operate machinery and equipment.

The product specified here may become unsafe if handled incorrectly. The assembly, operation and maintenance of machines or equipment including our products must be performed by an operator who is appropriately trained and experienced.

#### 3. Do not service or attempt to remove product and machinery/equipment until safety is confirmed.

1. The inspection and maintenance of machinery/equipment should only be performed after measures to prevent falling or runaway of the driven objects have been confirmed.
2. When the product is to be removed, confirm that the safety measures as mentioned above are implemented and the power from any appropriate source is cut, and read and understand the specific product precautions of all relevant products carefully.
3. Before machinery/equipment is restarted, take measures to prevent unexpected operation and malfunction.

#### 4. Contact SMC beforehand and take special consideration of safety measures if the product is to be used in any of the following conditions.

1. Conditions and environments outside of the given specifications, or use outdoors or in a place exposed to direct sunlight.
2. Installation on equipment in conjunction with atomic energy, railways, air navigation, space, shipping, vehicles, military, medical treatment, combustion and recreation, or equipment in contact with food and beverages, emergency stop circuits, clutch and brake circuits in press applications, safety equipment or other applications unsuitable for the standard specifications described in the product catalog.
3. An application which could have negative effects on people, property, or animals requiring special safety analysis.
4. Use in an interlock circuit, which requires the provision of double interlock for possible failure by using a mechanical protective function, and periodical checks to confirm proper operation.

### Caution

#### 1. The product is provided for use in manufacturing industries.

The product herein described is basically provided for peaceful use in manufacturing industries.  
If considering using the product in other industries, consult SMC beforehand and exchange specifications or a contract if necessary.  
If anything is unclear, contact your nearest sales branch.

### Limited warranty and Disclaimer/ Compliance Requirements

The product used is subject to the following “Limited warranty and Disclaimer” and “Compliance Requirements”.

Read and accept them before using the product.

#### Limited warranty and Disclaimer

1. The warranty period of the product is 1 year in service or 1.5 years after the product is delivered, whichever is first.\*2)  
Also, the product may have specified durability, running distance or replacement parts. Please consult your nearest sales branch.
2. For any failure or damage reported within the warranty period which is clearly our responsibility, a replacement product or necessary parts will be provided.  
This limited warranty applies only to our product independently, and not to any other damage incurred due to the failure of the product.
3. Prior to using SMC products, please read and understand the warranty terms and disclaimers noted in the specified catalog for the particular products.

##### \*2) Vacuum pads are excluded from this 1 year warranty.

A vacuum pad is a consumable part, so it is warranted for a year after it is delivered.  
Also, even within the warranty period, the wear of a product due to the use of the vacuum pad or failure due to the deterioration of rubber material are not covered by the limited warranty.

#### Compliance Requirements

1. The use of SMC products with production equipment for the manufacture of weapons of mass destruction (WMD) or any other weapon is strictly prohibited.
2. The exports of SMC products or technology from one country to another are governed by the relevant security laws and regulations of the countries involved in the transaction. Prior to the shipment of a SMC product to another country, assure that all local rules governing that export are known and followed.

### Caution

#### SMC products are not intended for use as instruments for legal metrology.

Measurement instruments that SMC manufactures or sells have not been qualified by type approval tests relevant to the metrology (measurement) laws of each country. Therefore, SMC products cannot be used for business or certification ordained by the metrology (measurement) laws of each country.

## Safety Instructions

Be sure to read the “Handling Precautions for SMC Products” (M-E03-3) and “Operation Manual” before use.

**SMC Corporation**