

Guide Cylinder/Compact Type

Series MGC

ø20, ø25, ø32, ø40, ø50

Linear Transfer Unit with compact guide body and front plate

Grease nipple offers easy lubrication for bearings

Space-saving
Length ▲20%
Height ▲18%
(In comparison with Series MGG□B32)

Lightweight
Mass ▲28%
(In comparison with Series MGG□B32)

Compact front plate and guide body

Air cushion is standard
Enables the impact to be absorbed at the stroke end when the cylinder is operated at high speeds.

Models without rear plate are available

- MGJ
- MGP
- MGQ
- MGG
- MGC**
- MGF
- MGZ
- MGT

Guide Cylinder/Compact Type

Series MGC

Compact type of Series MGG



Bore size (mm)	Standard stroke (mm)						
	75	100	125	150	200	250	300
20	●	●	●	●	●		
25	●	●	●	●	●	●	
32	●	●	●	●	●	●	●
40	●	●	●	●	●	●	●
50	●	●	●	●	●	●	●

Bore size (mm)	Long stroke (mm)										
	250	300	350	400	450	500	600	700	800	900	1000
20	●	●									
25			●	●	●	●					
32			●	●	●	●	●				
40			●	●	●	●	●	●	●		
50			●	●	●	●	●	●	●	●	●

P.392

- D-□
- X□
- Individual -X□

Guide Cylinder/Compact Type

Series MGC

∅20, ∅25, ∅32, ∅40, ∅50

How to Order

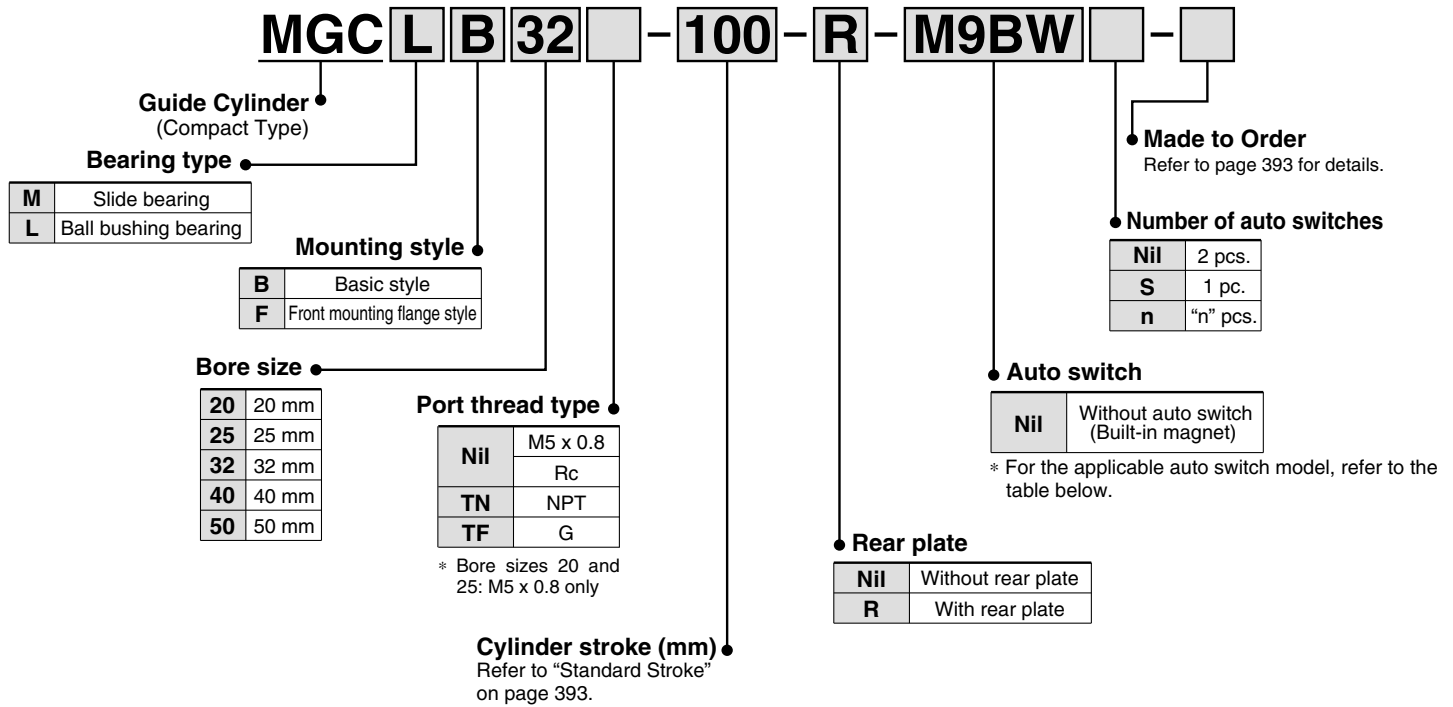

Applicable Auto Switch/Refer to pages 1719 to 1827 for further information on auto switches.

Type	Special function	Electrical entry	Indicator/light	Wiring (Output)	Load voltage		Auto switch model			Lead wire length (m)					Pre-wired connector	Applicable load	
					DC	AC	Applicable bore (mm)			0.5 (Nil)	1 (M)	3 (L)	5 (Z)	None (N)		IC circuit	Relay, PLC
							∅20, ∅25	∅32	∅40, ∅50								
Solid state switch	—	Grommet	Yes	3-wire (NPN)	5 V, 12 V	—	M9N			●	●	●	○	—	○	IC circuit	Relay, PLC
				3-wire (PNP)			M9P			●	●	●	○	—	○		
		Connector		2-wire	12 V		M9B			●	●	●	○	—	○	—	
	Grommet	3-wire (NPN)		24 V	5 V, 12 V		M9NW			●	●	●	○	—	○	IC circuit	
		3-wire (PNP)			5 V, 12 V		M9PW			●	●	●	○	—	○		
		2-wire		12 V	M9BW			●	●	●	○	—	○	—			
Water resistant (2-color indication) With diagnostic output (2-color indication)	Grommet	4-wire (NPN)	5 V, 12 V	H7BA			—	—	●	○	—	○	—				
—		—	—	H7NF			●	—	●	○	—	○	IC circuit				
Reed switch	—	Grommet	Yes	3-wire (NPN equivalent)	—	5 V	A96			●	—	●	—	—	—	—	
				None	24 V	12 V	100 V	A93			●	—	●	—	—	—	—
							100 V or less	A90			●	—	●	—	—	—	IC circuit
							100 V, 200 V	(B54)	B54	●	—	●	●	—	—	—	—
		200 V or less		(B64)	B64	●	—	●	—	—	—	—	—				
		Connector		—	—	C73C			●	—	●	●		●	—	—	
				24 V or less	—	C80C			●	—	●	●	●	—	IC circuit		
		Grommet		Yes	—	—	(B59W)	B59W	●	—	●	—	—	—	—		

* Lead wire length symbols: 0.5 m Nil (Example) M9NW
 1 m M (Example) M9NWM
 3 m L (Example) M9NWL
 5 m Z (Example) M9NWZ
 None N (Example) H7CN

* Solid state auto switches marked with "○" are produced upon receipt of order.
 * D-A9□V/M9□V/M9□WV/M9□A(V) types cannot be mounted.

* Since there are other applicable auto switches than listed, refer to page 406 for details.
 * For details about auto switches with pre-wired connector, refer to pages 1784 and 1785.
 * D-A9□/M9□/M9□W auto switches are shipped together (not assembled).
 (Only switch mounting brackets are assembled at the time of shipment.)

Caution

When using auto switches shown inside (), stroke end detection may not be possible depending on the One-touch fitting or speed controller model. Please contact SMC in this case.

JIS Symbol

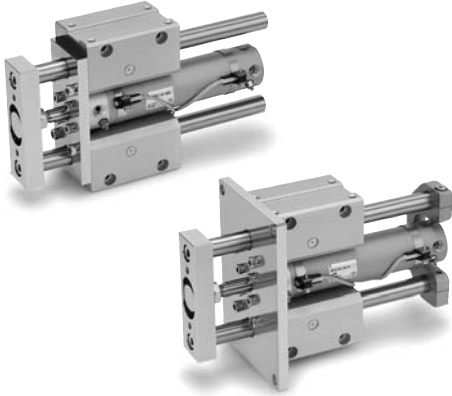
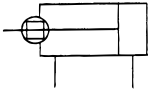

Specifications

Standard Stroke

Model (Bearing type)	Bore size (mm)	Standard stroke (mm)	Long stroke (mm)
MGCM (Slide bearing)	20	75, 100, 125, 150, 200	250, 300, 350, 400
	25	75, 100, 125, 150, 200, 250, 300	350, 400, 450, 500
32	350, 400, 450, 500, 600		
MGCL (Ball bushing bearing)	40		350, 400, 450, 500, 600, 700, 800
	50	350, 400, 450, 500, 600, 700, 800, 900, 1000	

* Intermediate strokes and short strokes other than the above are produced upon receipt of order.

Specifications

Model	MGC□□20	MGC□□25	MGC□□32	MGC□□40	MGC□□50	
Base cylinder	CDG1BA	Bore size	Port thread type	Stroke	Auto switch	
Bore size (mm)	20	25	32	40	50	
Action	Double acting					
Fluid	Air					
Proof pressure	1.5 MPa					
Maximum operating pressure	1.0 MPa					
Minimum operating pressure	0.15 MPa (Horizontal with no load)					
Ambient and fluid temperature	-10 to 60°C					
Piston speed	50 to 750 mm/s					
Cushion	Air cushion					
Base cylinder lubrication	Non-lube					
Stroke length tolerance	+1.9 +0.2 mm					
Non-rotating accuracy ^{Note 1)}	Slide bearing	±0.07°	±0.06°	±0.06°	±0.05°	±0.04°
	Ball bushing bearing	±0.06°	±0.05°	±0.04°	±0.04°	±0.04°
Piping port size (Rc, NPT, G) ^{Note 2)}	M5 x 0.8		1/8		1/4	

* 1 When the cylinder is retracted (initial value), the non-rotating accuracy without loads or deflection of the guide rods will be below the values shown in the table above as a guideline.

* 2 Bore sizes 20 and 25: M5 x 0.8 only



Made to Order Specifications
(For details, refer to pages 1829 to 1954, 1998.)

Symbol	Specifications
-XB6	Heat resistant cylinder (-10 to 150°C)
-XB13	Low speed cylinder (5 to 50 mm/s)
-XC4	With heavy duty scraper
-XC6 □	Made of stainless steel
-XC8	Adjustable stroke cylinder/Adjustable extension type
-XC9	Adjustable stroke cylinder/Adjustable retraction type
-XC11	Dual stroke cylinder/Single rod type
-XC13	Auto switch rail mounting style
-XC22	Fluororubber seals
-XC35	With coil scraper
-XC37	Larger throttle diameter of connecting port
-XC56	With knock pin holes
-XC73	Cylinder with lock (CDNG)
-XC74	With front plate for MGJ
-XC78	Auto switch mounting special dimensions at stroke end
-XC79	Machining tapped hole, drilled hole, and pin hole additionally
-X440	With piping ports for grease

Theoretical Output



Bore size (mm)	Rod size (mm)	Operating direction	Piston area (mm ²)	Operating pressure (MPa)								
				0.2	0.3	0.4	0.5	0.6	0.7	0.8	0.9	1.0
20	8	OUT	314	62.8	94.2	126	157	188	220	251	283	314
		IN	264	52.8	79.2	106	132	158	185	211	238	264
25	10	OUT	491	98.2	147	196	246	295	344	393	442	491
		IN	412	82.4	124	165	206	247	288	330	371	412
32	12	OUT	804	161	241	322	402	482	563	643	724	804
		IN	691	138	207	276	346	415	484	553	622	691
40	16	OUT	1260	252	378	504	630	756	882	1010	1130	1260
		IN	1060	212	318	424	530	636	742	848	954	1060
50	20	OUT	1960	392	588	784	980	1180	1370	1570	1760	1960
		IN	1650	330	495	660	825	990	1160	1320	1490	1650

Note) Theoretical output (N) = Pressure (MPa) x Piston area (mm²)

MGJ

MGP

MGQ

MGG

MGC

MGF

MGZ

MGT

D-□

-X□

Individual
-X□

Series MGC

Mass

Bore size (mm)		20	25	32	40	50
Basic mass	LB type (Ball bushing bearing/Basic style)	1.3	1.92	2.61	4.18	7.99
	LF type (Ball bushing bearing/Front mounting flange style)	1.82	2.56	3.33	5.47	9.49
	MB type (Slide bearing/Basic style)	1.29	1.89	2.55	4.08	7.71
	MF type (Slide bearing/Front mounting flange style)	1.81	2.53	3.27	5.37	9.21
Additional mass with rear plate		0.2	0.25	0.34	0.58	1.04
Additional mass per each 50 mm of stroke		0.14	0.17	0.25	0.4	0.61
Additional mass for long stroke		0.01	0.01	0.02	0.03	0.06
Additional mass with bracket		0.022	0.033	0.04	0.074	0.128

(kg)

Calculation: (Example)

MGCLB32-500-R

(Ball bushing bearing/Basic style, ø32/500st., Rear plate, Bracket)

- Basic mass.....2.61 (LB type)
- Additional mass with rear plate.....0.34
- Additional mass for stroke.....0.25/50 st
- Stroke.....500 st
- Additional mass for long stroke.....0.02
- Additional mass with bracket.....0.04

$$2.61 + 0.34 + 0.25 \times 500/50 + 0.02 + 0.04 = 5.51 \text{ kg}$$

Mass of Moving Parts

Bore size (mm)	20	25	32	40	50
Moving parts basic mass	0.35	0.57	0.74	1.29	2.65
Additional mass with rear plate	0.2	0.25	0.34	0.58	1.04
Additional mass per each 50 mm of stroke	0.11	0.14	0.2	0.33	0.51

(kg)

Calculation: (Example)

MGCLB32-500-R

- Standard mass of moving parts ...0.74
- Additional mass with rear plate0.34
- Additional mass for stroke0.2/50 st.
- Stroke500 st.

$$0.74 + 0.34 + 0.2 \times 500/50 = 3.08 \text{ kg}$$

Allowable Kinetic Energy by Air Cushion Mechanism

R: Rod side, H: Head side

Bore size (mm)	Effective cushion length (mm)	Allowable kinetic energy (J)
20	R: 7, H: 7.5	R: 0.35, H: 0.42
25	R: 7, H: 7.5	R: 0.56, H: 0.65
32	7.5	0.91
40	8.7	1.8
50	11.8	3.4

High kinetic energy generated by large loads and high speed operations can be absorbed by compressing air at the stroke end thus preventing shock and vibration being transmitted to the machine. If the kinetic energy is within the range of the table above, the life of the cushion packing can be expected to exceed a million operations. The air cushion has not been designed to control the piston speed in the end regions of the stroke. The load kinetic energy can be obtained by the following equation:

$$E_k = \frac{M+m}{2} \mathcal{U}^2 \quad \mathcal{U} = 1.4 \mathcal{U}_a$$

- Ek: Kinetic energy (J)
- M: Mass for the driven object (kg)
- m: Mass for movable part of cylinder (kg)
- \mathcal{U} : Maximum speed (m/s)
- \mathcal{U}_a : Average speed (m/s)

Note) Set \mathcal{U}_a so that rush speed into cushion \mathcal{U} should not exceed 0.75 m/s.

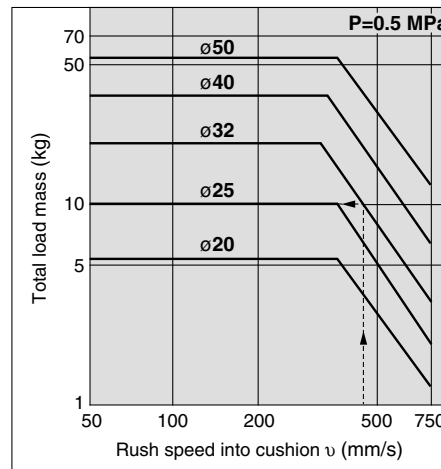

Also, selection can be made by using the graph above.

Example)

Find the maximum load mass when using a cylinder with ø32, stroke 500 mm, with rear plate as a lifter at an average speed of \mathcal{U}_a 300 mm/s.

Rush speed into cushion \mathcal{U} is as follows:

$$\mathcal{U} = 1.4 \times 300 = 420 \text{ mm/s.}$$

Extend upward from 420 mm/s on the abscissa in the graph until crossing at the line of bore size 32. Extend leftward from the intersection to find the total load mass 10 kg.

Subtract the moving parts' mass of 3.08 kg from this. (For moving parts, refer to "Mass of Moving Parts".) 6.92 kg will be obtained, which is equal to the maximum load mass.

Caution

In a horizontal application, pay attention to that the load mass should not exceed the allowable tip load given on pages 396 to 400.

Air-hydro

Low pressure hydraulic cylinder of 1.0 MPa or less
Through the concurrent use of a CC Series air-hydro unit, it becomes possible to operate at a constant or low speed or to effect an intermediate stop, just like a hydraulic unit, while using pneumatic equipment such as a valve.

MGCH Bearing type Mounting style Bore size Port thread type - Stroke - Equipped/Not equipped back plate
 ↓
 • Air-hydro

Specifications

Bore size (mm)	20, 25, 32, 40, 50
Action	Double acting
Fluid	Turbine oil
Proof pressure	1.5 MPa
Maximum operating pressure	1.0 MPa
Minimum operating pressure	0.18 MPa (Horizontal with no load)
Piston speed	15 to 300 mm/s
Cushion	Without
Ambient and fluid temperature	+5 to 60°C
Mounting	Basic style Front mounting flange style

* For specifications other than the above, refer to page 393.
 * Auto switch can be mounted.

Dimensions (Dimensions other than the below are the same as the standard type.)

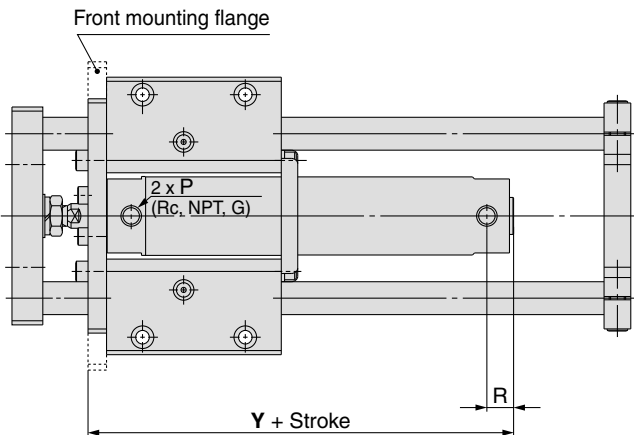

(mm)			
Bore size (mm)	P	R	Y
20	1/8	14	88
25	1/8	14	88
32	1/8	14	90
40	1/8	15	101
50	1/4	16	116

Copper and Fluorine-free (For CRT manufacturing process)

To prevent the influence of copper ions or halogen ions during CRT manufacturing processes, copper and fluorine materials are not used in the component parts.

20-MGC Bearing type Mounting style Bore size Port thread type - Stroke - Equipped/Not equipped back plate
 ↓
 • Copper and fluorine-free

Specifications

Bore size (mm)	20, 25, 32, 40, 50
Action	Double acting
Fluid	Air
Maximum operating pressure	1.0 MPa
Minimum operating pressure	0.15 MPa (Horizontal with no load)
Cushion	Air cushion
Mounting	Basic style Front mounting flange style

* For specifications other than the above, refer to page 393. For dimensions, refer to pages 402 and 403.
 * Auto switch can be mounted.

MGJ
 MGP
 MGQ
 MGG
MGC
 MGF
 MGZ
 MGT

D-□
 -X□
 Individual
 -X□

Series MGC

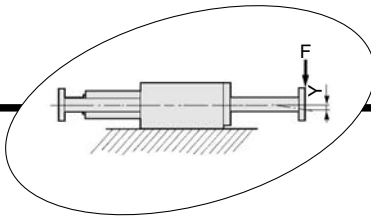

Slide Bearing Allowable End Load and Deflection

MGCM □ 20- Stroke -R

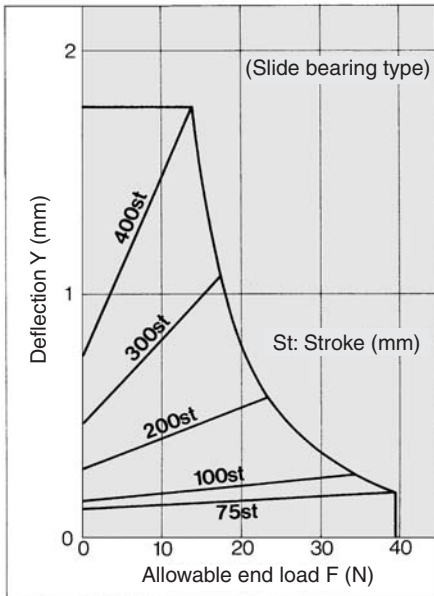

MGCM □ 25- Stroke -R

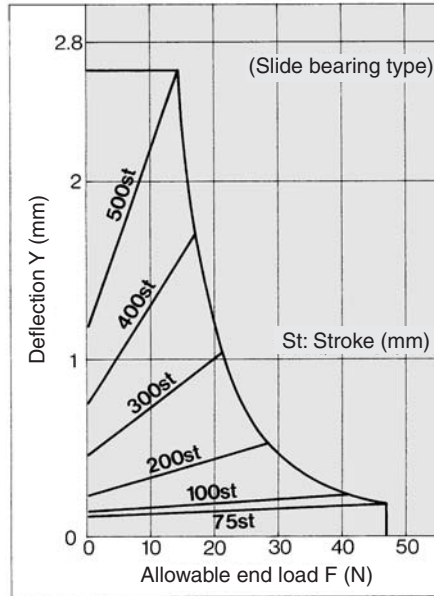

MGCM □ 32- Stroke -R

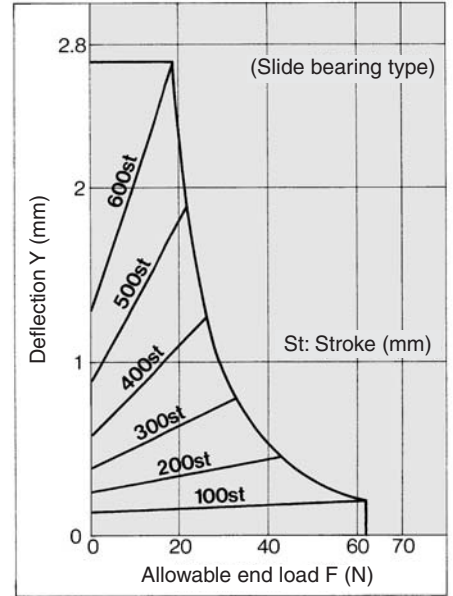

MGCM □ 40- Stroke -R

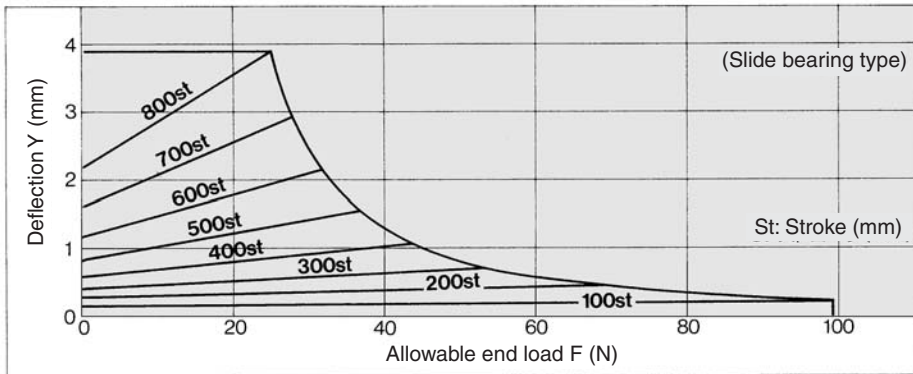

MGCM □ 50- Stroke -R

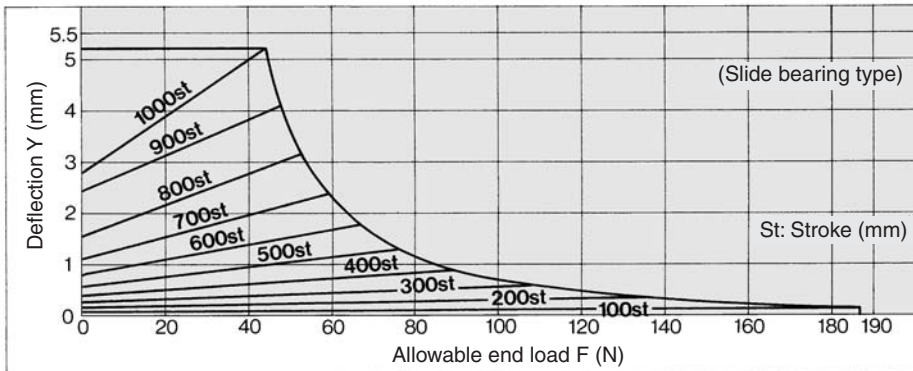

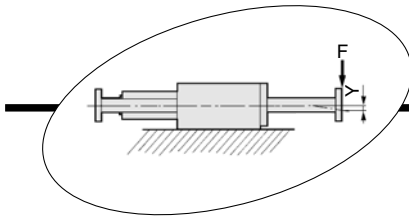

**Ball Bushing Bearing
Allowable End Load and Deflection**

MGCL □ 20- Stroke -R

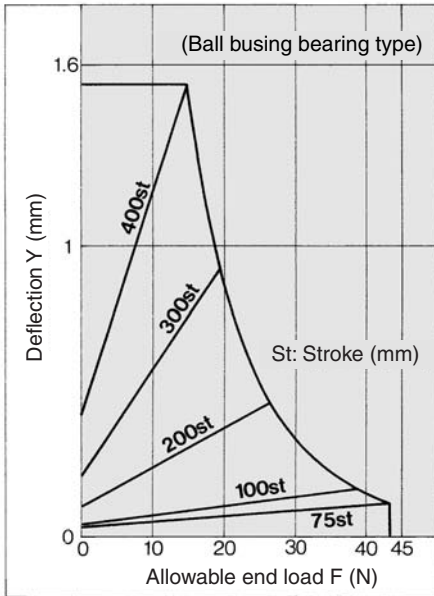

MGCL □ 25- Stroke -R

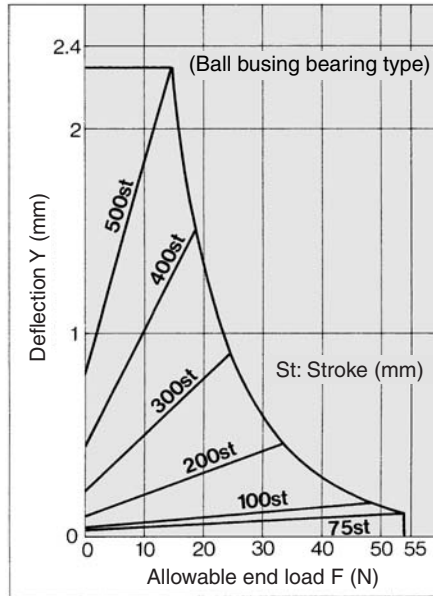

MGCL □ 32- Stroke -R

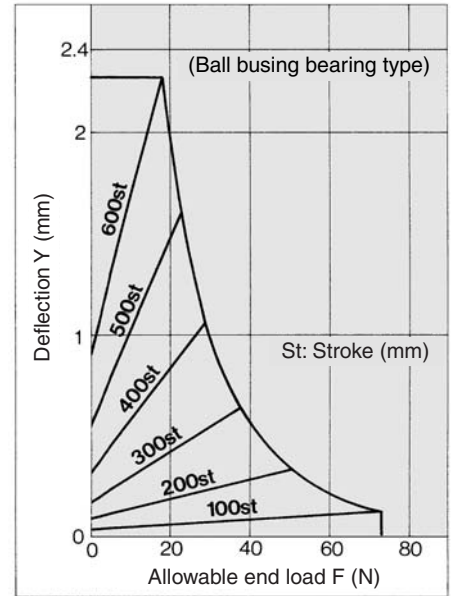

MGCL □ 40- Stroke -R

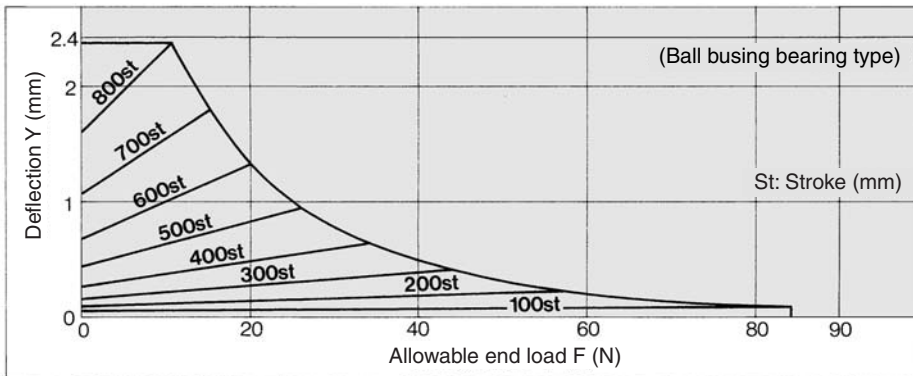

MGCL □ 50- Stroke -R

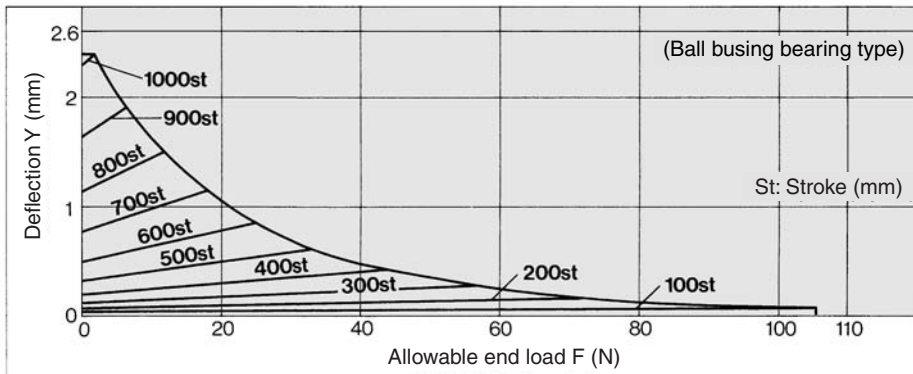

MGJ

MGP

MGQ

MGG

MGC

MGF

MGZ

MGT

D-□

-X□

Individual
-X□

Series MGC

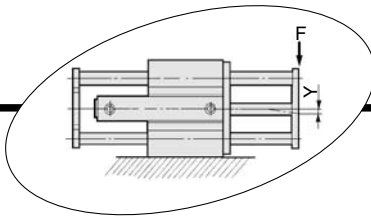

Slide Bearing Allowable End Load and Deflection

MGCM 20- Stroke -R

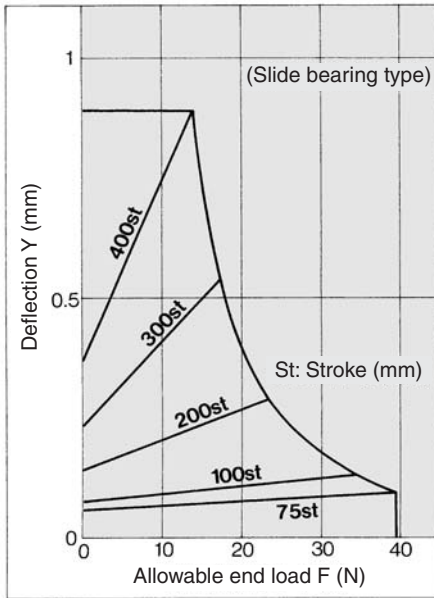

MGCM 25- Stroke -R

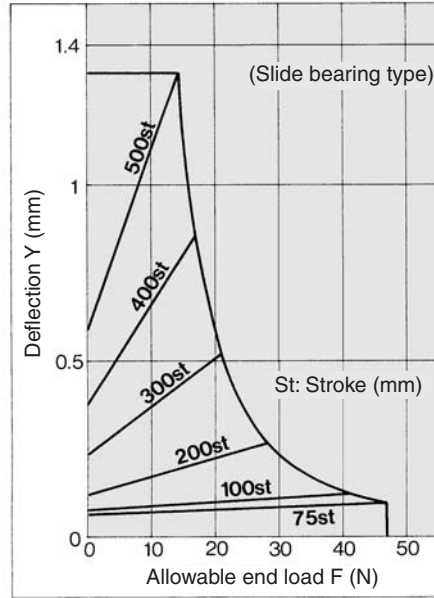

MGCM 32- Stroke -R

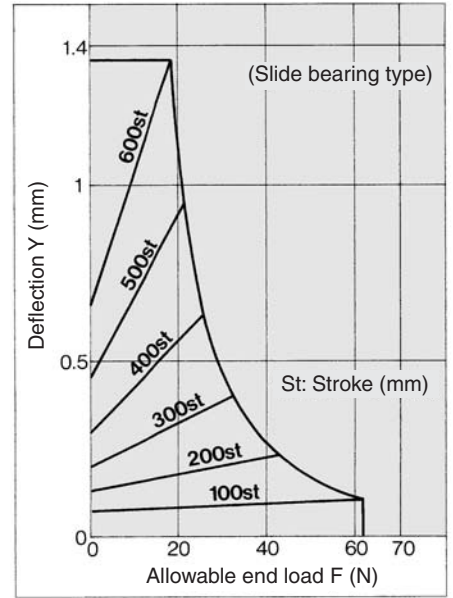

MGCM 40- Stroke -R

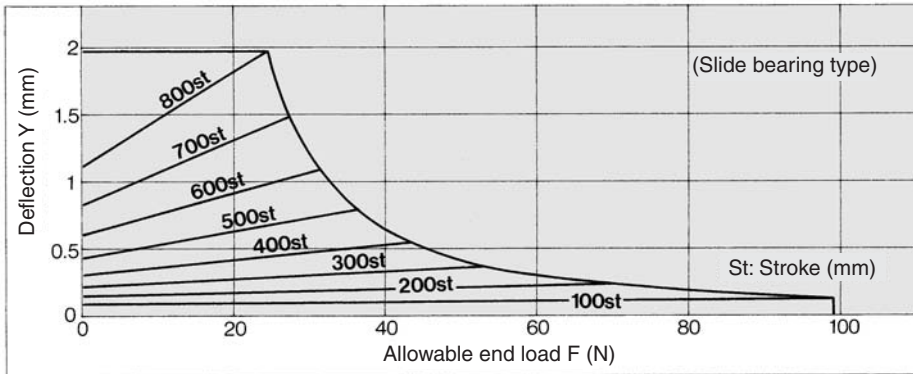

MGCM 50- Stroke -R

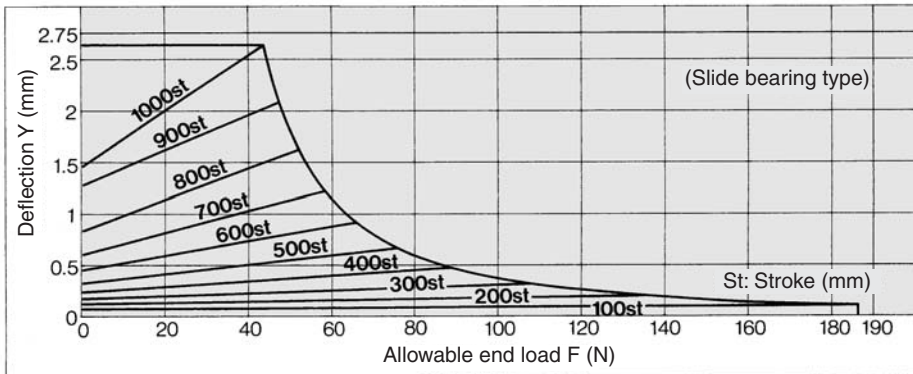

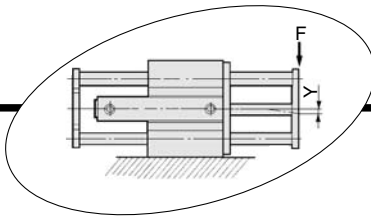

**Ball Bushing Bearing
Allowable End Load and Deflection**

MGCL 20-Stroke-R

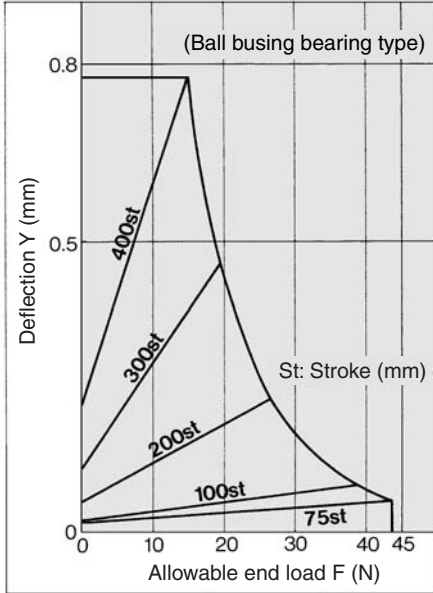

MGCL 25-Stroke-R

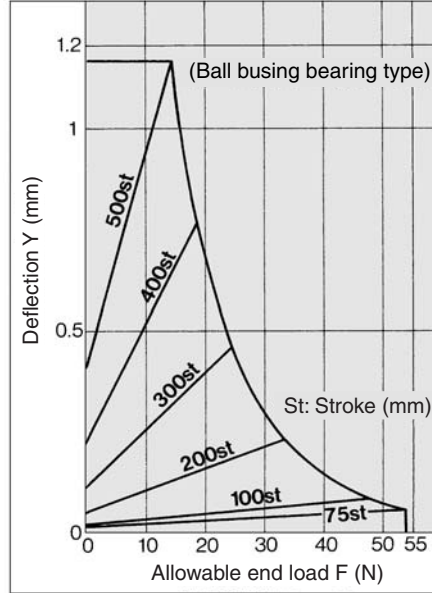

MGCL 32-Stroke-R

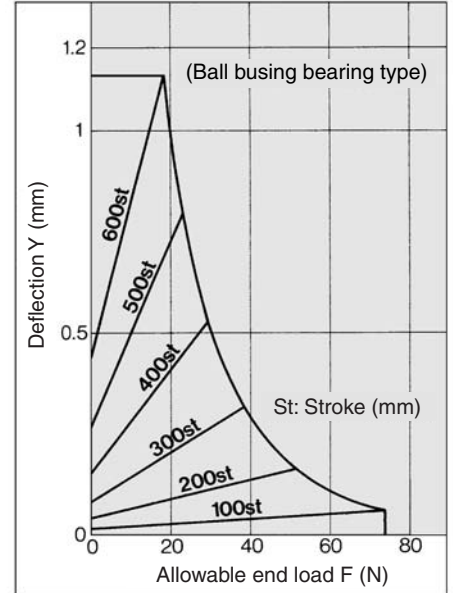

MGCL 40-Stroke-R

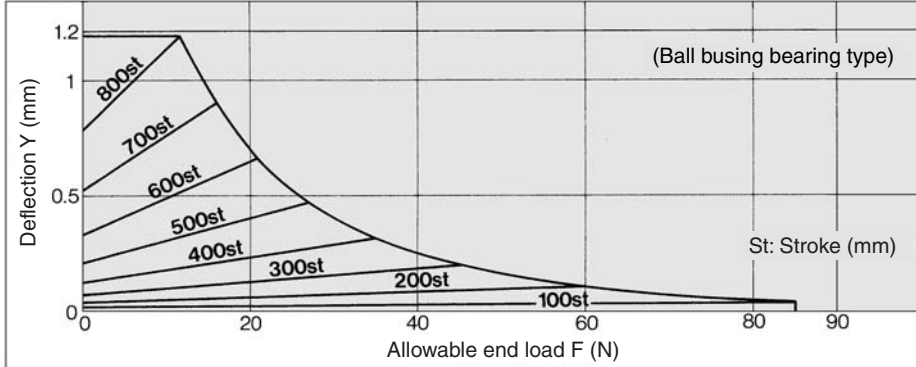

MGCL 50-Stroke-R

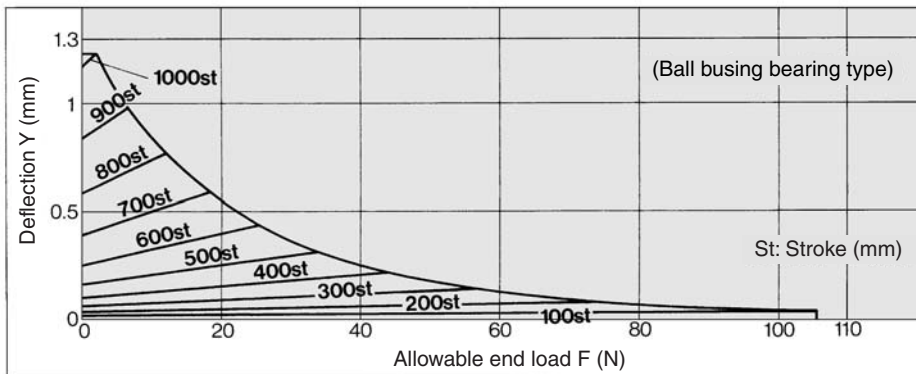

MGJ

MGP

MGQ

MGG

MGC

MGF

MGZ

MGT

D-□

-X□

Individual
-X□

Series MGC

Allowable Eccentric Load

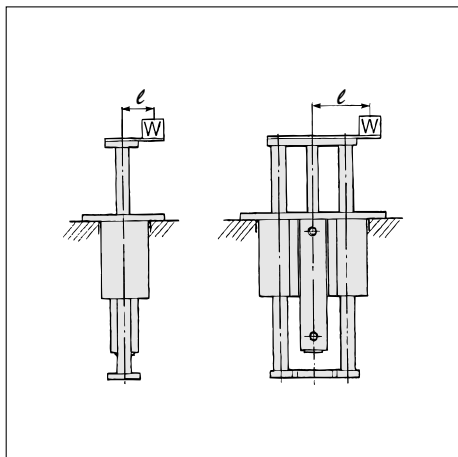

Slide bearing/
MGCM □□-Stroke-R

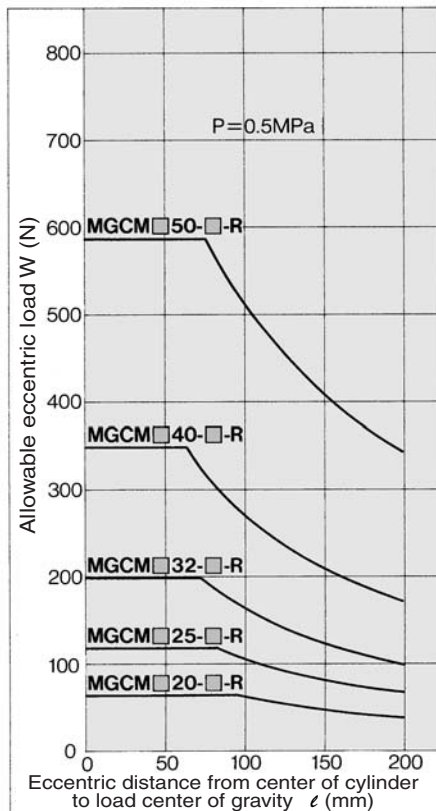

(Set the maximum allowable load so that it does not exceed the following percentages of the theoretical output: 40% for $\phi 20$, 50% for $\phi 25$ and $\phi 32$, 55% for $\phi 40$ and 60% or less for $\phi 50$, respectively.)

Ball bushing bearing/
MGCL □□-Stroke-R

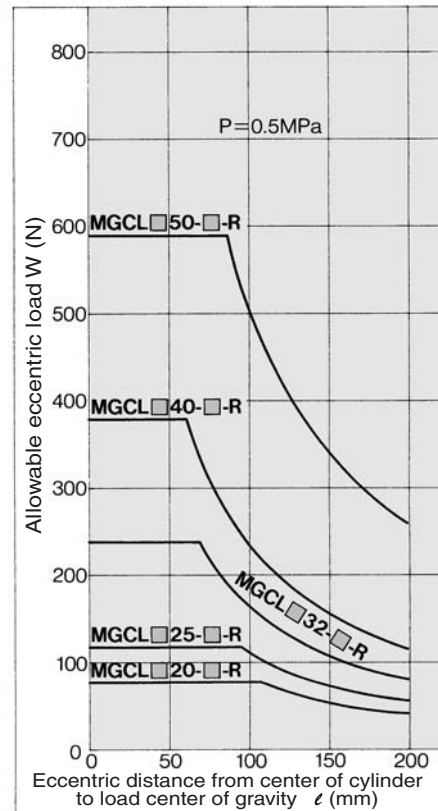

(Set the maximum allowable load so that it does not exceed the following percentages of the theoretical output: 40% for $\phi 20$, 50% for $\phi 25$ and $\phi 32$, 55% for $\phi 40$ and 60% or less for $\phi 50$, respectively.)

Construction: With Rear Plate

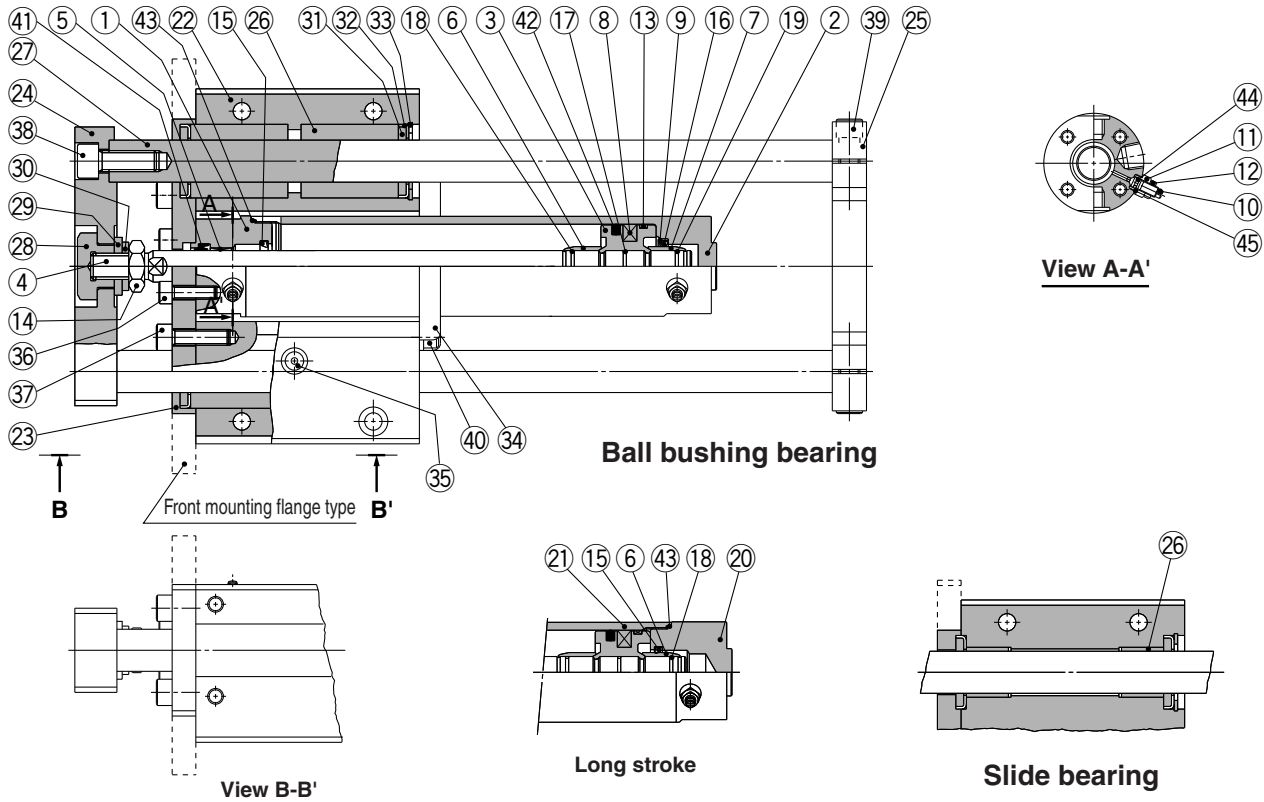

Component Parts

No.	Description	Material	Note
1	Rod cover	Aluminum alloy	Clear hard anodized
2	Tube cover	Aluminum alloy	Clear hard anodized
3	Piston	Aluminum alloy	Chromated
4	Piston rod	Carbon steel	Hard chrome plated $\phi 20, \phi 25$ are stainless steel
5	Bushing	Bearing alloy	
6	Cushion ring A	Brass	
7	Cushion ring B	Brass	(Note 1)
8	Magnet	—	
9	Seal retainer	Rolled steel	Nickel plated (Nothing for long stroke)
10	Cushion valve	Rolled steel	Electroless nickel plated
11	Valve retainer	Rolled steel	Electroless nickel plated
12	Lock nut	Rolled steel	Nickel plated
13	Wear ring	Resin	
14	Rod end nut	Rolled steel	Nickel plated
15	Cushion seal A	Urethane	
16	Cushion seal B	Urethane	(Note 2)
17	Piston gasket	NBR	
18	Cushion ring gasket A	NBR	
19	Cushion ring gasket B	NBR	W/ cushion ring gasket A: Except standard $\phi 20$ and $\phi 25$
20	Head cover	Aluminum alloy	Clear hard anodized For long stroke
21	Cylinder tube	Aluminum alloy	Hard anodized
22	Guide body	Aluminum alloy	White anodized
23	Small flange	Rolled steel	Flat nickel plated For basic type
23	Large flange		For front mounting flange style
24	Front plate	Rolled steel	Flat nickel plated
25	Rear plate	Cast iron	Platinum sliver
26	Slide bearing	Bearing alloy	For slide bearing
26	Ball bushing bearing	—	For ball bushing bearing
27	Guide rod	Carbon steel	Hard chrome plated For slide bearing
27		High carbon chrome bearing steel	Quenched, hard chrome plated For ball bushing bearing
28	End bracket	Carbon steel	Flat nickel plated
29	Washer	Rolled steel	Nickel plated

Note 1) Common with cushion ring A: Except standard $\phi 20$ and $\phi 25$
 Note 2) Common with cushion packing A: Except standard $\phi 20$ and $\phi 25$
 Note 3) In the case of the one without rear plate, 25 and 39 will not be required.

Component Parts

No.	Description	Material	Note
30	Spring washer	Steel wire	Nickel plated
31	Felt	Felt	
32	Holder	Stainless steel	
33	Type C retaining ring for hole	Carbon tool steel	Nickel plated
34	Bracket	Stainless steel	
35	Nipple	—	Nickel plated
36	Hexagon socket head cap screw	Chromium molybdenum steel	Nickel plated For cylinder mounting
37	Hexagon socket head cap screw	Chromium molybdenum steel	Nickel plated Small/Large flange mounting
38	Hexagon socket head cap screw	Chromium molybdenum steel	Nickel plated For front plate mounting
39	Hexagon socket head cap screw	Chromium molybdenum steel	Nickel plated For rear plate mounting
40	Hexagon socket head cap screw	Chromium molybdenum steel	Nickel plated For bracket mounting
41	Rod seal	NBR	
42	Piston seal	NBR	
43	Tube gasket	NBR	
44	Valve seal	NBR	
45	Valve retainer gasket	NBR	

Replacement Parts/Seal Kit

Bore size (mm)	Kit no.	Contents
20	CG1A20-PS	Set of nos. above 41, 42, 43, 44, 45
25	CG1A25-PS	
32	CG1A32-PS	
40	CG1A40-PS	

* Seal kit includes 41 to 45. Order the seal kit, based on each bore size.

* Seal kit includes a grease pack (10 g). Order with the following part number when only the grease pack is needed.

Grease pack part number: GR-S-010 (10 g)

⚠ Caution

When disassembling cylinders with bore sizes of $\phi 20$ through $\phi 40$, grip the double flat part of either the tube cover or the rod cover with a vise and loosen the other side with a wrench or an adjustable angle wrench, and then remove the cover. When re-tightening, tighten approximately 2 degrees more than the original position. (Cylinders with $\phi 50$ or larger bore sizes are tightened with a large tightening torque and cannot be disassembled. Please contact SMC when disassembly is required.)

MGJ

MGP

MGQ

MGG

MGC

MGF

MGZ

MGT

D-□

-X□

Individual
-X□

Series MGC

Dimensions

Basic style: With rear plate

MGC□B□□-□-R

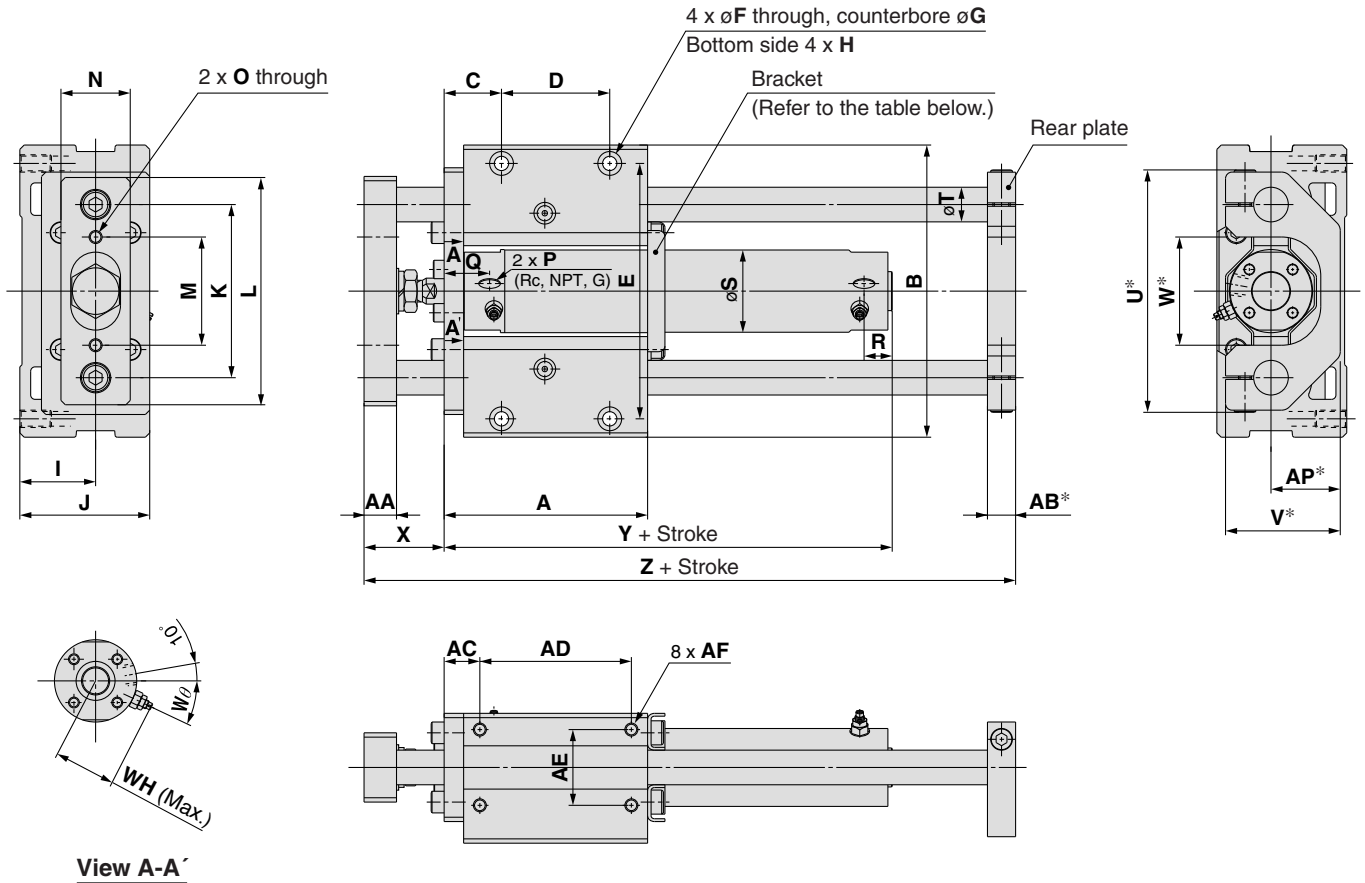

(mm)

Bore size (mm)	Stroke range (mm)	A	AA	AB	AC	AD	AE	AF	AP	B	C	D	E	F	G	H
20	75, 100, 125, 150, 200	84	12	13	15.5	62	25	M5 x 0.8 depth 10	22	106	24	45	90	5.6	9.5 depth 6	M6 x 1 depth 10
25	75, 100, 125, 150 200, 250, 300	89	16	13	16.5	65	30	M6 x 1 depth 12	27	120	26.5	45	103	6.8	11 depth 8	M8 x 1.25 depth 14
32		94	16	13	16.5	70	35	M6 x 1 depth 12	32	135	26.5	50	118	6.8	11 depth 8	M8 x 1.25 depth 14
40		107	19	16	22	75	40	M8 x 1.25 depth 16	37	160	34.5	50	140	8.6	14 depth 10	M10 x 1.5 depth 18
50		142	25	19	22	110	45	M10 x 1.5 depth 20	42	194	37	80	170	10.5	17 depth 12	M12 x 1.75 depth 21

Bore size (mm)	I	J	K	L	M	N	O	P ^{Note 2)}	Q	R	S	T	U	V	W	WH	W _θ	X	Y	Z
20	25	44	60	80	38	25	M6 x 1	M5 x 0.8	21	12	26	12	86	40	36	23	30°	30	80	140
25	30	52	70	95	46	32	M6 x 1	M5 x 0.8	21	12	31	13	98	47	44	25	30°	37	80	153
32	35	60	80	105	50	32	M6 x 1	1/8	21	12	38	16	112	53	50	28.5	25°	37	82	161
40	40	70	95	125	60	38	M8 x 1.25	1/8	25	12	47	20	132	63	60	33	20°	44	92	188
50	45	82.5	115	150	75	50	M8 x 1.25	1/4	26	14	58	25	162	73	70	40.5	20°	55	104	241

Without Rear Plate

Bore size (mm)	Z
20	119
25	131
32	136
40	156
50	202

Long Stroke

Bore size (mm)	Stroke range (mm)	R	Y
20	250 to 400	14	88
25	350 to 500	14	88
32	350 to 600	14	90
40	350 to 800	15	101
50	350 to 1000	16	116

Bracket Mounting Stroke

Bore size (mm)	Bracket mounting stroke
20	100 st or more
25	125 st or more
32	150 st or more
40	200 st or more
50	250 st or more

Note 1) Dimensions marked with "*" are not required for the one without rear plate.

Note 2) Bore sizes 20 and 25: M5 x 0.8 only. For 32 or larger bore sizes, Rc, NPT and G ports can be selected.

Dimensions

Front face mounting flange style: With rear plate

MGC□F□□-□-R

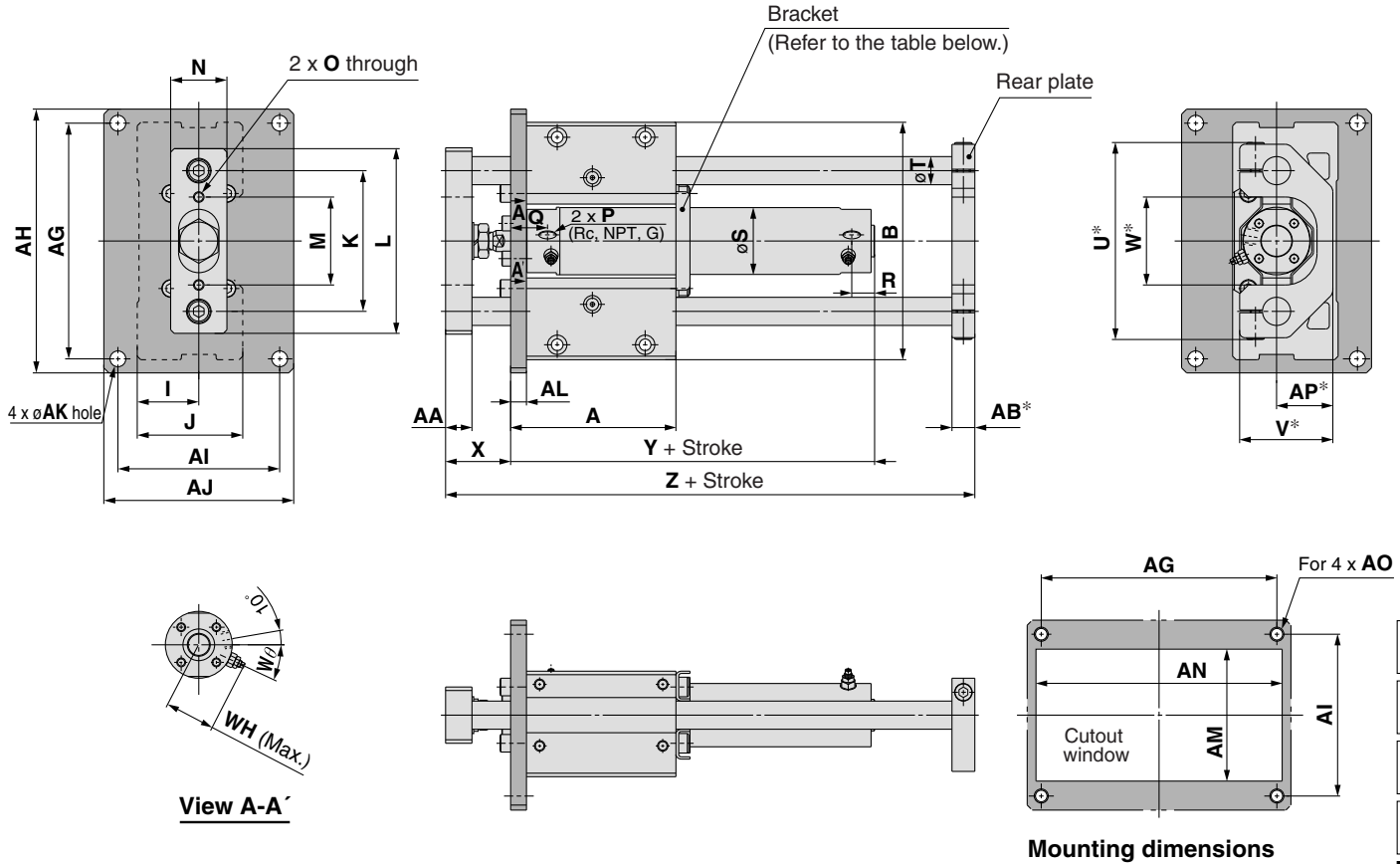

Bore size (mm)	Stroke range (mm)	A	AA	AB	AG	AH	AI	AJ	AK	AL	AM	AN	AO	AP	B	I	J	K	L	M	N
20	75, 100, 125, 150, 200	84	12	13	105	120	75	90	6.6	9	55	110	M6	22	106	25	44	60	80	38	25
25	75, 100, 125, 150 200, 250, 300	89	16	13	120	136	84	100	9	9	65	125	M8	27	120	30	52	70	95	46	32
32		94	16	13	134	150	92	108	9	9	75	140	M8	32	135	35	60	80	105	50	32
40		107	19	16	160	176	110	125	9	12	85	165	M8	37	160	40	70	95	125	60	38
50		142	25	19	190	210	115	135	11	12	95	200	M10	42	194	45	82.5	115	150	75	50

Bore size (mm)	O	P ^{Note 2)}	Q	R	S	T	U	V	W	WH	W _θ	X	Y	Z
20	M6 x 1	M5 x 0.8	21	12	26	12	86	40	36	23	30°	30	80	140
25	M6 x 1	M5 x 0.8	21	12	31	13	98	47	44	25	30°	37	80	153
32	M6 x 1	1/8	21	12	38	16	112	53	50	28.5	25°	37	82	161
40	M8 x 1.25	1/8	25	12	47	20	132	63	60	33	20°	44	92	188
50	M8 x 1.25	1/4	26	14	58	25	162	73	70	40.5	20°	55	104	241

Without Rear Plate

Bore size (mm)	Z
20	119
25	131
32	136
40	156
50	202

Long Stroke

Bore size (mm)	Stroke range (mm)	R	Y
20	250 to 400	14	88
25	350 to 500	14	88
32	350 to 600	14	90
40	350 to 800	15	101
50	350 to 1000	16	116

Bracket Mounting Stroke

Bore size (mm)	Bracket mounting stroke
20	100 st or more
25	125 st or more
32	150 st or more
40	200 st or more
50	250 st or more

Note 1) Dimensions marked with "*" are not required for the one without rear plate.
 Note 2) Bore sizes 20 and 25: M5 x 0.8 only. For 32 or larger bore sizes, Rc, NPT and G ports can be selected.

- MGJ
- MGP
- MGQ
- MGG
- MGC
- MGF
- MGZ
- MGT

- D-□
- X□
- Individual -X□

Series MGC

Auto Switch Proper Mounting Position (Detection at Stroke End) and Its Mounting Height

D-A9 D-M9/M9□W

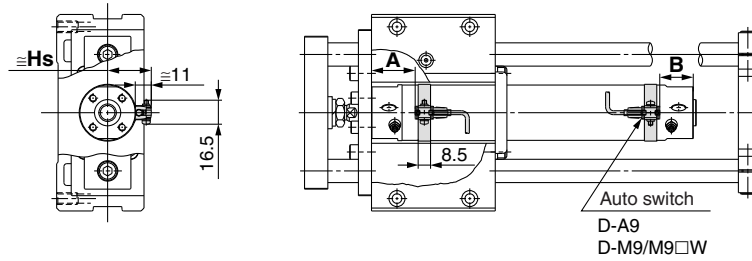

D-C7/C8/H7

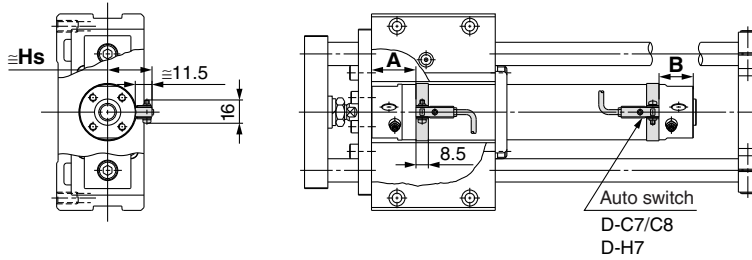

D-B5/B6/G5/K5

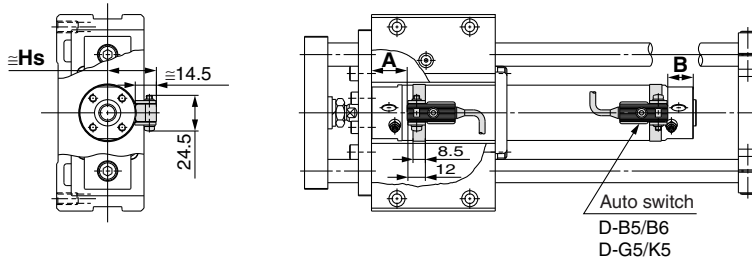

D-B7/B8/G7/K7

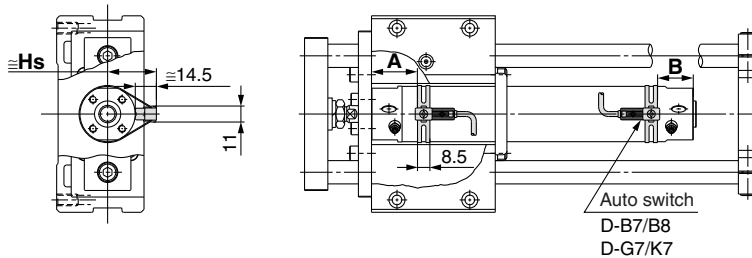

Auto Switch Proper Mounting Position

Auto switch model	D-A9□		D-M9□ D-M9□W		D-B7□/B80 D-B73C D-B80C D-G79/K79 D-K79C		D-C7□ D-C80 D-C73C D-C80C		D-B5□ D-B64		D-B59W		D-H7□W D-H7BAL D-H7□ D-H7C D-H7NF		D-G59F D-G5□W D-K59W D-G5BAL D-G5□ D-K59 D-G5NTL	
	A	B	A	B	A	B	A	B	A	B	A	B	A	B	A	B
20	29	20 (28)	33	24 (32)	30.5	21.5 (29.5)	29.5	20.5 (28.5)	23.5	14.5 (22.5)	26.5	17.5 (25.5)	28.5	19.5 (27.5)	25	16 (24)
25	29	20 (28)	33	24 (32)	30.5	21.5 (29.5)	29.5	20.5 (28.5)	23.5	14.5 (22.5)	26.5	17.5 (25.5)	28.5	19.5 (27.5)	25	16 (24)
32	30	21 (29)	34	25 (33)	31.5	22.5 (30.5)	30.5	21.5 (29.5)	24.5	15.5 (23.5)	27.5	18.5 (26.5)	29.5	20.5 (28.5)	26	17 (25)
40	35	23 (32)	39	27 (36)	36.5	24.5 (33.5)	35.5	23.5 (32.5)	29.5	17.5 (26.5)	32	20.5 (29.5)	34.5	22.5 (31.5)	31	19 (28)
50	42	28 (40)	46	32 (36)	43.5	29.5 (41.5)	42.5	28.5 (40.5)	36.5	22.5 (34.5)	39.5	25.5 (37.5)	41.5	27.5 (39.5)	38	24 (36)

Auto Switch Mounting Height

Auto switch model	D-A9□ D-M9□ D-M9□W		D-C7□/C80 D-H7□ D-H7NF D-H7BAL		D-C73C D-C80C		D-B7□/B80 D-B73C D-B80C D-G79/K79 D-K79C D-G59F		D-G5□/K59 D-G5□W D-K59W D-B5□/B64 D-B59W D-H7C D-G5BAL D-G5NTL	
Bore size (mm)	Hs	Hs	Hs	Hs	Hs	Hs	Hs	Hs	Hs	
20	24	24.5	27	27.5						
25	26.5	27	29.5	30						
32	30	30.5	33	33.5						
40	34.5	35	37.5	38						
50	40	40.5	43	43.5						

* () : Set values for long stroke, double rod
 Note) Adjust the auto switch after confirming the operating conditions in the actual setting.

Minimum Auto Switch Mounting Stroke

n: No. of auto switches (mm)

Auto switch model	No. of auto switches mounted		
	1 pc.	2 pcs.	"n" pcs.
		Same surface	Same surface
D-A9□ D-M9□ D-M9□W	10	45 ^{Note)}	45 + 45 (n-2)
D-C7□ D-C80	10	50	50 + 45 (n-2)
D-H7□ D-H7□W D-H7BAL D-H7NF	10	60	60 + 45 (n-2)
D-C73C D-C80C D-H7C	10	65	65 + 50 (n-2)
D-B5□ D-B64 D-G5□ D-K59□ D-B59W	10	75	75 + 55 (n-2)
D-B7□ D-B80 D-G79 D-K79	10	45	50 + 45 (n-2)

Note) For cylinders with 2 auto switches D-A93/M9□/M9□W.

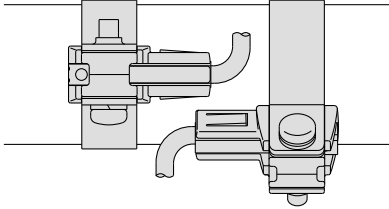
Auto switch model	With 2 auto switches	
	Same surface	
	 <p>The auto switch is mounted by slightly displacing it in a direction (cylinder tube circumferential exterior) so that the auto switch and lead wire do not interfere with each other.</p>	
D-A93	Less than 50 strokes	
D-M9□ D-M9□W	Less than 55 strokes	

- MGJ
- MGP
- MGQ
- MGG
- MGC**
- MGF
- MGZ
- MGT

- D-□
- X□
- Individual
-X□

Operating Range

Auto switch model	Bore size (mm)				
	20	25	32	40	50
D-A9□	7	6	8	8	8
D-M9□/M9□W	5	5.5	5	5.5	6.5
D-B7□/B80 D-B73C/B80C	8	10	9	10	10
D-C7□/C80 D-C73C/C80C	8	10	9	10	10
D-B5□/B64	8	10	9	10	10
D-B59W	13	13	14	14	14
D-G79/K79/K79C	8	10	9	10	10
D-H7□/H7□W D-H7BAL/H7NF	4	4	4.5	5	6
D-H7C	7	8.5	9	10	9.5
D-G5□/K59 D-G5□W/K59W D-G5NTL/G5BAL	4	4	4.5	5	6
D-G59F	5	5	5.5	6	7
D-G5NBL	35	40	40	45	45

* Since this is a guideline including hysteresis, not meant to be guaranteed (assuming approximately ±30% dispersion).
There may be the case it will vary substantially depending on an ambient environment.

Switch Mounting Bracket/Part No.

Auto switch model	Bore size (mm)				
	ø20	ø25	ø32	ø40	ø50
D-A9□ D-M9□ D-M9□W	Note) ①BMA2-020 ②BJ3-1	Note) ①BMA2-025 ②BJ3-1	Note) ①BMA2-032 ②BJ3-1	Note) ①BMA2-040 ②BJ3-1	Note) ①BMA2-050 ②BJ3-1
D-C7□/C80 D-C73C D-C80C D-H7□/H7C D-H7□W D-H7BAL D-H7NF	BMA2-020	BMA2-025	BMA2-032	BMA2-040	BMA2-050
D-B5□/B64 D-B59W D-G5□/K59 D-G5□W/K59W D-G5BAL/G59F D-G5NTL D-G5NBL	BA-01	BA-02	BA-32	BA-04	BA-05
D-B7□/B80 D-B73C/B80C D-G79/K79 D-K79C	BM1-01	BM1-02	BM1-32	BM1-04	BM1-05

Note) Two kinds of auto switch mounting brackets are used as a set.

[Mounting screw set made of stainless steel]

The following set of mounting screws made of stainless steel is available. Use it in accordance with the operating environment. (Please order the auto switch mounting bracket separately, since it is not included.)

BBA3: For D-B5/B6/G5/K5 types

BBA4: D-C7/C8/H7 types

Note) Refer to pages 1813 and 1814 for the details of BBA3 and BBA4.

D-H7BAL and G5BAL auto switches are set on the cylinder with the stainless steel screws above when shipped. When an auto switch is shipped independently, BBA3 or BBA4 is attached.

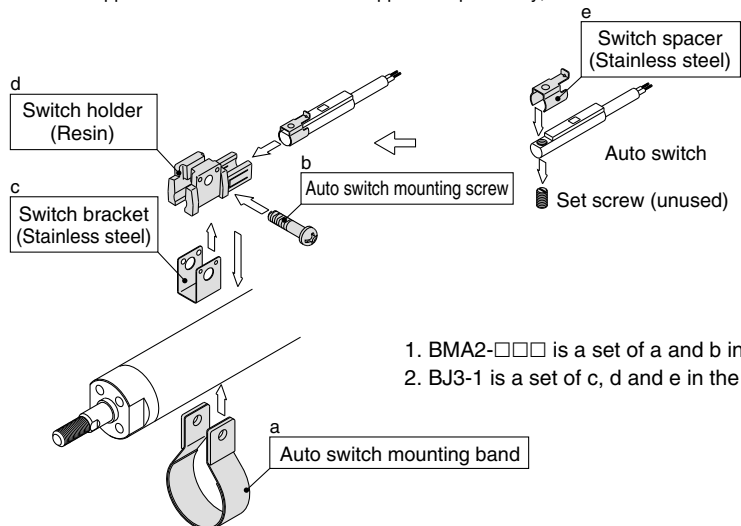

1. BMA2-□□□ is a set of a and b in the figures.
2. BJ3-1 is a set of c, d and e in the figures.

Besides the models listed in How to Order, the following auto switches are applicable. Refer to pages 1719 to 1827 for the detailed specifications.

Auto switch type	Part no.	Electrical entry (Fetching direction)	Features
Reed	D-C73, C76, B73, B73C, B76	Grommet (In-line)	—
	D-C80, B80C		Without indicator light
	D-B53		—
Solid state	D-H7A1, H7A2, H7B, G79, K79, K79C		—
	D-H7NW, H7PW, H7BW		Diagnostic indication (2-color)
	D-G5NTL		With timer

* For solid state auto switches, auto switches with a pre-wired connector are also available. Refer to pages 1784 and 1785 for details.

* Normally closed (NC = b contact) solid state auto switches (D-F9G/F9H types) are also available. Refer to page 1746 for details.

* Wide range detection type, solid state auto switches (D-G5NBL type) are also available. Refer to page 1776 for details.



Series MGC Specific Product Precautions

Be sure to read before handling.

Refer to front matters 42 and 43 for Safety Instructions and pages 3 to 11 for Actuator and Auto Switch Precautions.

Installations and Adjustment

Warning

1. Installing a protective cover (In the case of rear plate)

During mounting, handling and operation, the rear plate makes reciprocating movements. Therefore, pay careful attention not to insert your hand, etc., between the cylinder and the rear plate.

When you are going to fit this product to the outside of your equipment, take preventative measures such as installing a protective cover.

Protective cover installation

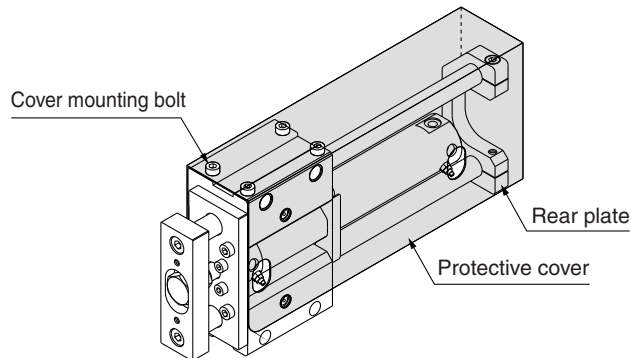
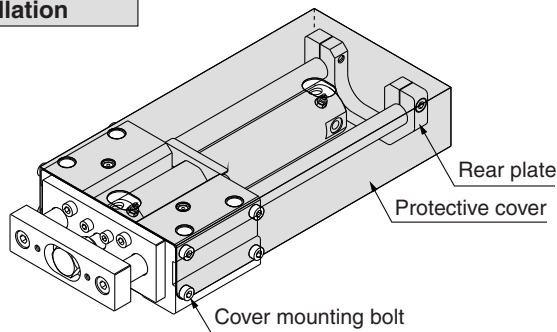

Caution

1. Use caution that no scratch or dent will be given to the slide part of the guide rod.

Because the outer circumference of the guide rod is manufactured with precise tolerances, even a slight deformation, scratch, or gouge can lead to faulty operation or reduced durability.

2. When fitting the guide body, use the guide body which has high flatness of the fitting surface.

If the guide rod has twisted, operation resistance will become abnormally higher and the bearing will wear at an early stage, thereby resulting in poor performance.

3. Mount in locations where maintenance will be easy.

Ensure enough clearance around the cylinder to allow for unobstructed maintenance and inspection work.

4. Do not adjust the rod stroke by moving the rear plates,

as doing so will cause the rear plates to come into direct contact with the guide body or the bracket mounting bolt. The resulting impact cannot be absorbed easily, the stroke position cannot be maintained, and faulty operation may result.

5. Lubrication

The bearing can be used in an oilless state, but when you are going to oil the bearings, do so by using a nipple so that no foreign matter will be mixed.

For the grease, we recommended using high-quality lithium soap-based grease no. 2.

6. Mounting orientation

For ceiling mounting (the opening of the rear plate is downward.), the rear plate may interfere with the basic cylinder head end due to the deflection of guide rods. Please consult with SMC.

MGJ

MGP

MGQ

MGG

MGC

MGF

MGZ

MGT

D-□

-X□

Individual
-X□

Guide Cylinder

Series *MLGC*

Built-in Fine Lock Cylinder Compact Type

- **Locking in both directions is possible.**

Locking in either side of cylinder stroke is possible, too.

- **Maximum piston speed: 500 mm/s**

It can be used at 50 to 500 mm/s provided that it is within the allowable kinetic energy range.

- **Air cushion is standard.**

Enables the impact to be absorbed at the stroke end when the cylinder is operated at high speeds.

- **Cylinder position can be detected.**

Built-in magnet for auto switches is provided in all models.

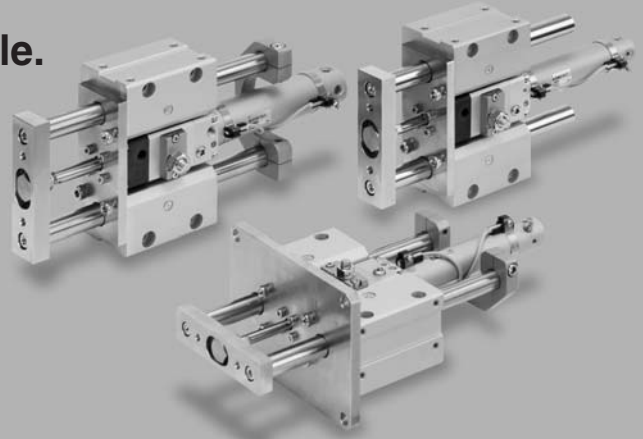

A linear transfer cylinder unit with a built-in locking mechanism and a guide rod integrated in a compact design.

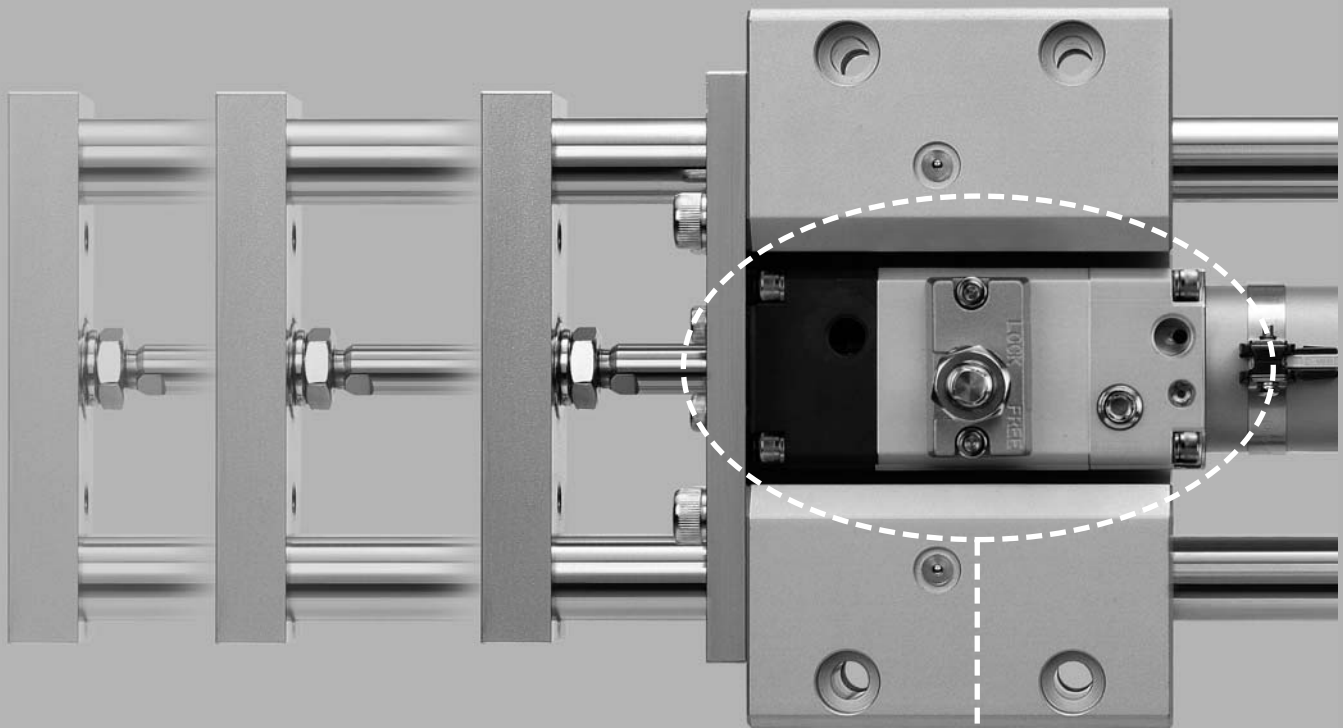

Three-types of locking mechanism

Locking method	Spring locking	Pneumatic locking	Spring and pneumatic locking
Features	<ul style="list-style-type: none"> ● Discharging the unlocking air causes the lock to operate. 	<ul style="list-style-type: none"> ● Supplying a pressure to the pressurized locking port enables the change of holding force as desired. 	<ul style="list-style-type: none"> ● Supplying a pressure to the pressurized locking port enables the change of holding force as desired. ● Discharging the unlocking air causes the lock to operate.

CLJ2

CLM2

CLG1

CL1

MLGC

CNG

MNB

CNA

CNS

CLS

CLQ

RLQ

MLU

MLGP

ML1C

D-

-X

Individual
-X

Guide Cylinder: Built-in Fine Lock Cylinder Compact Type

Series **MLGC**

ø20, ø25, ø32, ø40

How to Order

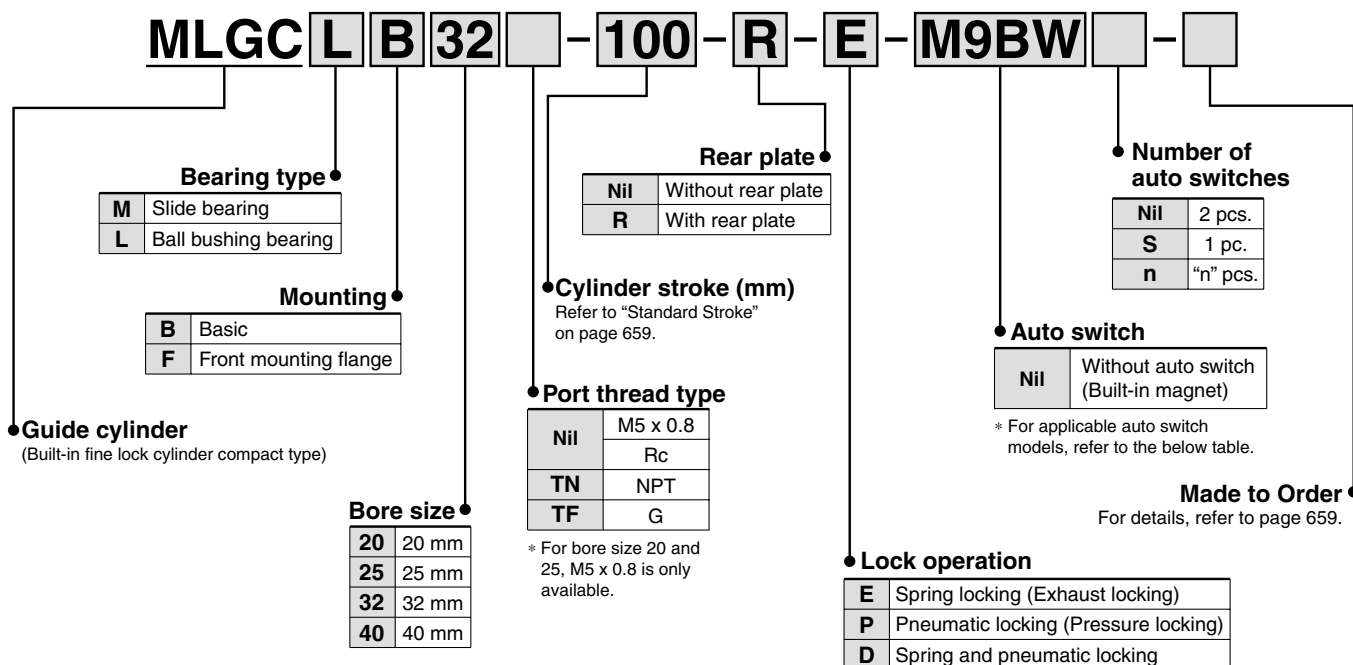

Applicable Auto Switches / For detailed auto switch specifications, refer to pages 1719 to 1827.

Type	Special function	Electrical entry	Indicator light	Wiring (Output)	Load voltage		Auto switch model			Lead wire length (m)					Pre-wired connector	Applicable load		
					DC	AC	Applicable tubing I.D.			0.5 (Nil)	1 (M)	3 (L)	5 (Z)	None (N)		IC circuit	Relay, PLC	
							ø20, ø25	ø32	ø40									
Solid state switch	Diagnostic indication (2-color indication)	Grommet	Yes	3-wire (NPN)	24 V	5 V, 12 V	—	M9N			●	—	●	○	—	○	IC circuit	Relay, PLC
				3-wire (PNP)				M9P			●	—	●	○	—	○		
		Connector	Yes	2-wire	12 V	M9B			●	—	●	○	—	○	—			
				3-wire (NPN)		H7C			●	—	●	●	●	—				
	Water resistant (2-color indication)	Grommet	Yes	3-wire (PNP)	24 V	5 V, 12 V	—	M9NW			●	●	●	○	—	○	IC circuit	
				2-wire				M9PW			●	●	●	○	—	○		
				4-wire (NPN)				M9BW			●	●	●	○	—	○		
Reed switch	Diagnostic indication (2-color indication)	Grommet	Yes	3-wire (NPN equivalent)	24 V	12 V	—	H7BA			—	—	●	○	—	○	—	
				H7NF				●	—	●	○	—	○					
				A96				●	—	●	—	—	—	—				
		Connector	Yes	None	2-wire	24 V	12 V	—	A93			●	—	●	—	—	—	IC circuit
									A90			●	—	●	—	—	—	
									(B54) B54			●	—	●	●	—	—	
		Grommet	Yes	None	2-wire	24 V	12 V	—	(B64) B64			●	—	●	—	—	—	—
C73C									●	—	●	●	●	—				
Connector	Yes	None	2-wire	24 V	12 V	—	C80C			●	—	●	●	●	—	IC circuit		
							(B59W) B59W			●	—	●	—	—	—			

* Lead wire length symbols: 0.5 m Nil (Example) M9NW
 1 m M (Example) M9NWM
 3 m L (Example) M9NWL
 5 m Z (Example) M9NWZ
 None N (Example) H7CN

* Solid state auto switches marked with "○" are produced upon receipt of order.
 * D-A9□V, M9□V, M9□WV, and D-M9□A(V) cannot be mounted.

* Since there are other applicable auto switches than listed, refer to page 666 for details.
 * For details about auto switches with pre-wired connector, refer to pages 1784 and 1785.
 * D-A9□, M9□, M9□W are shipped together (not assembled).
 (Only switch mounting bracket is assembled at the time of shipment.)

Caution

When using auto switches shown inside (), stroke end detection may not be possible depending on the One-touch fitting or speed controller model. Please contact SMC in this case.

Guide Cylinder Built-in Fine Lock Cylinder Compact Type **Series MLGC**

JIS Symbol

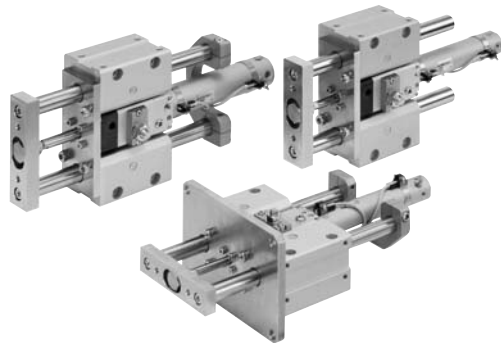
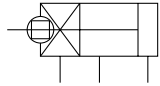

Made to Order
(For details, refer to page 1847.)

Symbol	Specifications
XC79	Machining tapped hole, drilled hole and pin hole additionally

Model / Specifications

Standard Stroke

Model (Bearing type)	Bore size (mm)	Standard stroke (mm)	Long stroke (mm)
MLGCM (Slide bearing)	20	75, 100, 125, 150, 200	250, 300, 350, 400
	25		350, 400, 450, 500
MLGCL (Ball bushing bearing)	32	75, 100, 125, 150, 200, 250, 300	350, 400, 450, 500, 600
	40		350, 400, 450, 500, 600, 700, 800

* Intermediate strokes and short strokes other than the above are produced upon receipt of order.

Specifications

Model	MLGC□□20	MLGC□□25	MLGC□□32	MLG□□40	
Basic cylinder	CDLG1BA	Bore size	Thread type	Stroke - Lock operation - Auto switch	
Bore size (mm)	20	25	32	40	
Action	Double acting				
Fluid	Air				
Proof pressure	1.5 MPa				
Maximum operating pressure	1.0 MPa				
Minimum operating pressure	0.2 MPa (Horizontal with no load)				
Ambient and fluid temperature	-10 to 60°C				
Piston speed*1	50 to 500 mm/s				
Cushion	Air cushion				
Base cylinder lubrication	Non-lube				
Stroke length tolerance	+1.9 +0.2 mm				
Non-rotating accuracy*2	Slide bearing	±0.06°	±0.05°	±0.05°	±0.04°
	Ball bushing bearing	±0.04°	±0.04°	±0.04°	±0.04°
Piping port size*3 (Rc, NPT, G)	Cylinder port	M5 x 0.8		1/8	
	Lock port	1/8			
Lock operation	<input type="checkbox"/> Spring locking (Exhaust locking) <input type="checkbox"/> Pneumatic locking (Pressure locking) <input type="checkbox"/> Spring and pneumatic locking				

*1 Constraints associated with the allowable kinetic energy are imposed on the speeds at which the piston can be locked. The maximum speed of 750 mm/s can be accommodated if the piston is to be locked in the stationary state for the purpose of drop prevention.

*2 When the cylinder is retracted (initial value), with no load or without deflection of the guide rod, the non-rotating accuracy shall be the value in the table or less.

*3 For bore size 20 and 25, M5 x 0.8 is only available.

Fine Lock Specifications

Lock operation	Spring locking (Exhaust locking)	Spring and pneumatic locking	Pneumatic locking (Pressure locking)
Fluid	Air		
Maximum operating pressure	0.5 MPa		
Unlocking pressure	0.3 MPa or more		0.1 MPa or more
Lock starting pressure	0.25 MPa or less		0.05 MPa or less
Locking direction	Both directions		

Theoretical Output



Bore size (mm)	Rod size (mm)	Operating direction	Piston area (mm ²)	Operating pressure (MPa)										
				0.2	0.3	0.4	0.5	0.6	0.7	0.8	0.9	1.0		
20	8	OUT	314	62.8	94.2	126	157	188	220	251	283	314		
		IN	264	52.8	79.2	106	132	158	185	211	238	264		
25	10	OUT	491	98.2	147	196	246	295	344	393	442	491		
		IN	412	82.4	124	165	206	247	288	330	371	412		
32	12	OUT	804	161	241	322	402	482	563	643	724	804		
		IN	691	138	207	276	346	415	484	553	622	691		
40	16	OUT	1260	252	378	504	630	756	882	1010	1130	1260		
		IN	1060	212	318	424	530	636	742	848	954	1060		

Note) Theoretical output (N) = Pressure (MPa) x Piston area (mm²)

CLJ2

CLM2

CLG1

CL1

MLGC

CNG

MNB

CNA

CNS

CLS

CLQ

RLQ

MLU

MLGP

ML1C

D-□

-X□

Individual
-X□

Series MLGC

Mass

Bore size (mm)		20	25	32	40
Basic mass	LB type (Ball bushing bearing / Basic)	2.8	4.45	4.54	8.12
	LF type (Ball bushing bearing / Front mounting flange)	3.52	5.42	5.52	9.61
	MB type (Slide bearing / Basic)	2.74	4.35	4.44	7.84
	MF type (Slide bearing / Front mounting flange)	3.45	5.31	5.42	9.33
Additional mass with rear plate		0.29	0.47	0.47	0.8
Additional mass per each 50 mm of stroke		0.21	0.32	0.34	0.54
Additional mass for long stroke		0.01	0.01	0.02	0.03

Calculation: (Example)

MLGCLB32-500-R-D

(Ball bushing bearing / Basic, ø32/500 st., with rear plate)

- Basic mass..... 4.54 (LB type)
 - Additional mass with rear plate..... 0.47
 - Additional stroke mass..... 0.34/50 st
 - Stroke..... 500 st
 - Additional mass for long stroke..... 0.02
- 4.54 + 0.47 + 0.34 x 500/50 + 0.02 = 8.43 kg

Allowable Kinetic Energy when Locking

Bore size (mm)	20	25	32	40
Allowable kinetic energy (J)	0.26	0.42	0.67	1.19

In terms of specific load conditions, the allowable kinetic energy indicated in the table above is equivalent to a 50% load ratio at 0.5 MPa, and a piston speed of 300 mm/sec. Therefore, if the operating conditions are below these values, calculations are unnecessary.

1. Apply the following formula to obtain the kinetic energy of the load.

E_k : Kinetic energy of load (J)

$$E_k = \frac{1}{2} m v^2$$

m: Load mass (kg)
(Load mass + Moving parts mass)

v: Piston speed (m/s) (Average speed x 1.2)

2. The piston speed will exceed the average speed immediately before locking. To determine the piston speed for the purpose of obtaining the kinetic energy of load, use 1.2 times the average speed as a guide.
3. The relation between the speed and the load of the respective tube bores is indicated in the diagram below. Use the cylinder in the range below the line.
4. During locking, the lock mechanism must absorb the thrust of the cylinder, in addition to the kinetic energy of the load. Therefore, in order to insure the proper braking force, even within a given allowable kinetic energy level, there is an upper limit to the size of the load. Thus, a horizontally mounted cylinder must be operated below the solid line, and a vertically mounted cylinder must be operated below the dotted line.

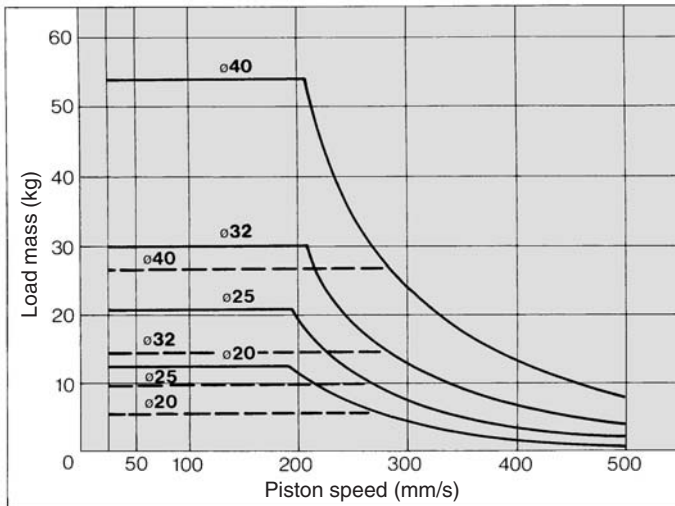

Holding Force of Spring Locking (Max. Static Load)

Bore size (mm)	20	25	32	40
Holding force (N)	196	313	443	784

(Note) Holding force at piston rod extended side decreases approximately 15%.

Moving Parts Mass

Bore size (mm)	20	25	32	40
Moving parts basic mass	0.59	1.17	1.17	2.21
Additional mass with rear plate	0.29	0.47	0.47	0.8
Additional mass per each 50 mm of stroke	0.18	0.28	0.29	0.46

Calculation: (Example)

MLGCLB32-500-R-D

- Moving parts basic mass..... 1.17
 - Additional mass with rear plate..... 0.47
 - Additional stroke mass..... 0.29/50 st
 - Stroke..... 500 st
- 1.17 + 0.47 + 0.29 x 500/50 = 4.54 kg

Holding Force of Pneumatic Locking (Max. Static Load)

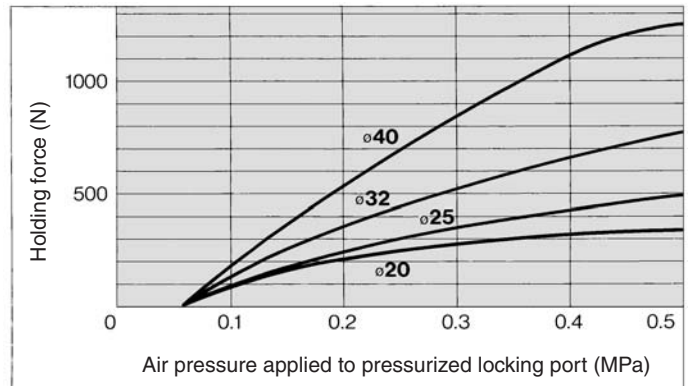

1. The holding force is the lock's ability to hold a static load that does not involve vibrations or shocks, after it is locked without a load. Therefore, to use the cylinder near the upper limit of the constant holding force, be aware of the following:

- If the piston rod slips because the lock's holding force has been exceeded, the brake shoe could become damaged, resulting in a reduced holding force or shortened life.
- To use the lock for drop prevention purposes, the load to be attached to the cylinder must be within 35% of the cylinder's holding force.
- Do not use the cylinder in the locked state to sustain a load that involves impact.

Stopping Accuracy (Not including tolerance of control system.)

Locking method	Piston speed (mm/s)			
	50	100	300	500
Spring locking (Exhaust locking)	±0.4	±0.5	±1.0	±2.0
Pneumatic locking (Pressure locking) Spring and pneumatic locking	±0.2	±0.3	±0.5	±1.5

Condition/ Load: 25% of thrust force at 0.5 MPa
Solenoid valve: mounted to the lock port

⚠ Caution

Recommended Pneumatic Circuit / Caution on Handling

For detailed specifications about the fine lock cylinder CLG1 series, refer to pages 596 to 599.

Construction: With Rear Plate

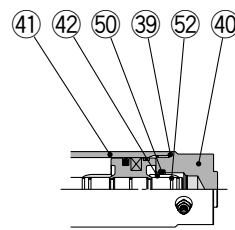
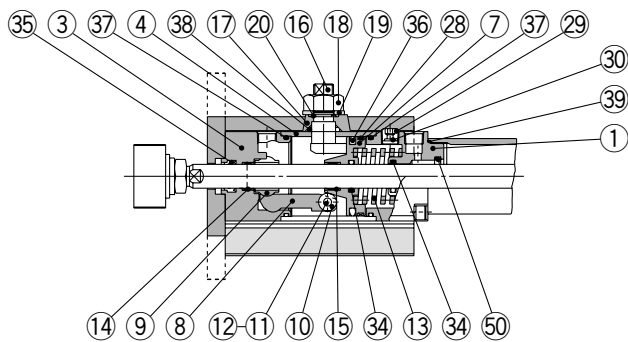
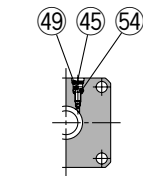
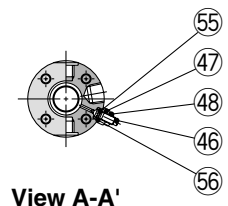
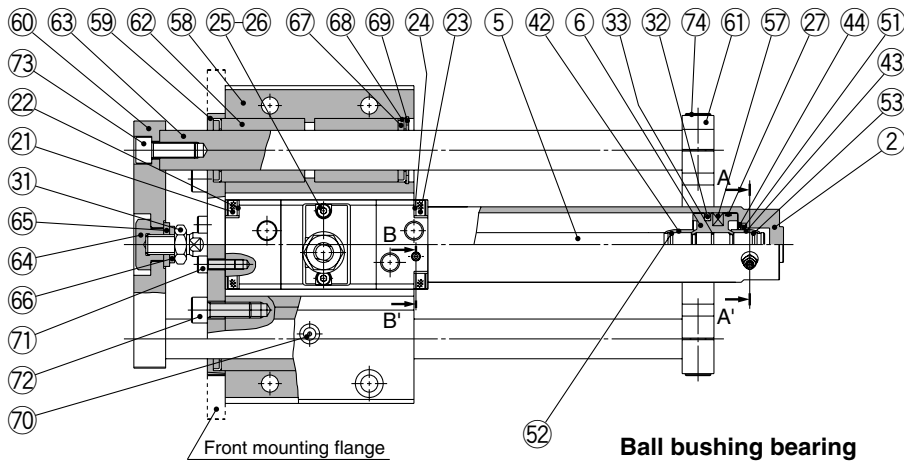

Long stroke

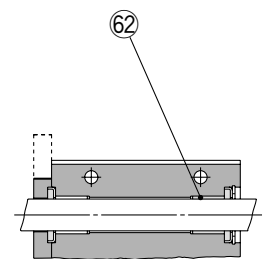

Slide bearing

Component Parts

No.	Description	Material	Description
1	Rod cover	Aluminum alloy	Clear hard anodized
2	Tube cover	Aluminum alloy	Hard anodized
3	Cover	Carbon steel	Nitrided
4	Intermediate cover	Aluminum alloy	Clear hard anodized
5	Piston rod	Carbon steel	Hard chrome plated $\phi 20, \phi 25$ are stainless steel.
6	Piston	Aluminum alloy	Chromated
7	Brake piston	Carbon steel	Nitrided
8	Brake arm	Carbon steel	Nitrided
9	Brake shoe	Special friction material	
10	Roller	Carbon steel	Nitrided
11	Pin	Carbon steel	Heat treated
12	Retaining ring	Stainless steel	
13	Brake spring	Spring steel wire	Dacrodized For spring locking, spring/pneumatic locking
14	Bushing	Oil-impregnated sintered alloy	
15	Bushing	Oil-impregnated sintered alloy	
16	Manual lock release cam	Chromium molybdenum steel	Nitrided, Nickel plated
17	Cam guide	Carbon steel	Nitrided, painted
18	Lock nut	Rolled steel	Nickel plated
19	Flat washer	Rolled steel	Nickel plated
20	Retaining ring	Stainless steel	
21	Hexagon socket head cap screw	Chromium molybdenum steel	Nickel plated
22	Spring washer	Steel wire	Nickel plated
23	Hexagon socket head cap screw	Chromium molybdenum steel	Nickel plated
24	Spring washer	Steel wire	Nickel plated
25	Hexagon socket head cap screw	Chromium molybdenum steel	Nickel plated
26	Spring washer	Steel wire	Nickel plated
27	Wear ring	Resin	
28	Wear ring	Resin	
29	Hexagon socket head plug	Carbon steel	Nickel plated For spring locking
30	Element	Bronze	
31	Rod end nut	Rolled steel	Nickel plated
32	Piston seal	NBR	
33	Piston gasket	NBR	
34	Rod seal A	NBR	
35	Rod seal B	NBR	
36	Brake piston seal	NBR	
37	Intermediate cover gasket	NBR	
38	Cam gasket	NBR	

Note) 61, 74 will not be required for without rear plate.

Component Parts

No.	Description	Material	Description
39	Cylinder tube gasket	NBR	
40	Head cover	Aluminum alloy	White hard anodized
41	Cylinder tube	Aluminum alloy	Hard anodized
42	Cushion valve A	Brass	
43	Cushion valve B	Brass	
44	Seal retainer	Rolled steel	Zinc chromated
45	Cushion valve A	Chromium molybdenum steel	Electroless nickel plated
46	Cushion valve B	Rolled steel	Electroless nickel plated
47	Valve retainer	Rolled steel	Electroless nickel plated
48	Lock nut	Rolled steel	Electroless nickel plated
49	Retaining ring	Stainless steel	
50	Cushion seal A	Urethane	
51	Cushion seal B	Urethane	
52	Cushion ring gasket A	NBR	
53	Cushion ring gasket B	NBR	
54	Valve seal A	NBR	
55	Valve seal B	NBR	
56	Valve retainer gasket	NBR	
57	Magnet	—	
58	Guide body	Aluminum alloy	Clear anodized
59	Small flange	Rolled steel	Flat nickel plated Basic
59	Large flange	Rolled steel	Flat nickel plated Front mounting flange
60	Front plate	Rolled steel	Flat nickel plated
61	Rear plate	Cast iron	Platinum silver
62	Slide bearing	Bearing alloy	For slide bearing
62	Ball bushing bearing	—	For ball bushing bearing
63	Guide rod	Carbon steel	Hard chrome plated For slide bearing
63	Guide rod	High carbon chrome bearing steel	Quenched, Hard chrome plated For ball bushing bearing
64	End bracket	Carbon steel	Flat nickel plated
65	Washer	Rolled steel	Nickel plated
66	Spring washer	Steel wire	Nickel plated
67	Felt	Felt	
68	Holder	Stainless steel	
69	Type C retaining ring for hole	Carbon tool steel	Nickel plated
70	Grease nipple	—	Nickel plated
71	Hexagon socket head cap screw	Chromium molybdenum steel	Nickel plated For cylinder mounting
72	Hexagon socket head cap screw	Chromium molybdenum steel	Nickel plated For large/small flange mounting
73	Hexagon socket head cap screw	Chromium molybdenum steel	Nickel plated For front plate mounting
74	Hexagon socket head cap screw	Chromium molybdenum steel	Nickel plated For rear plate mounting

CLJ2

CLM2

CLG1

CL1

MLGC

CNG

MNB

CNA

CNS

CLS

CLQ

RLQ

MLU

MLGP

ML1C

D-□

-X□

Individual

-X□

Series MLGC

Dimensions

Basic: With rear plate

MLGC□B□□-□-R-□

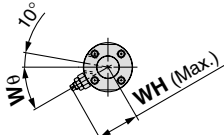
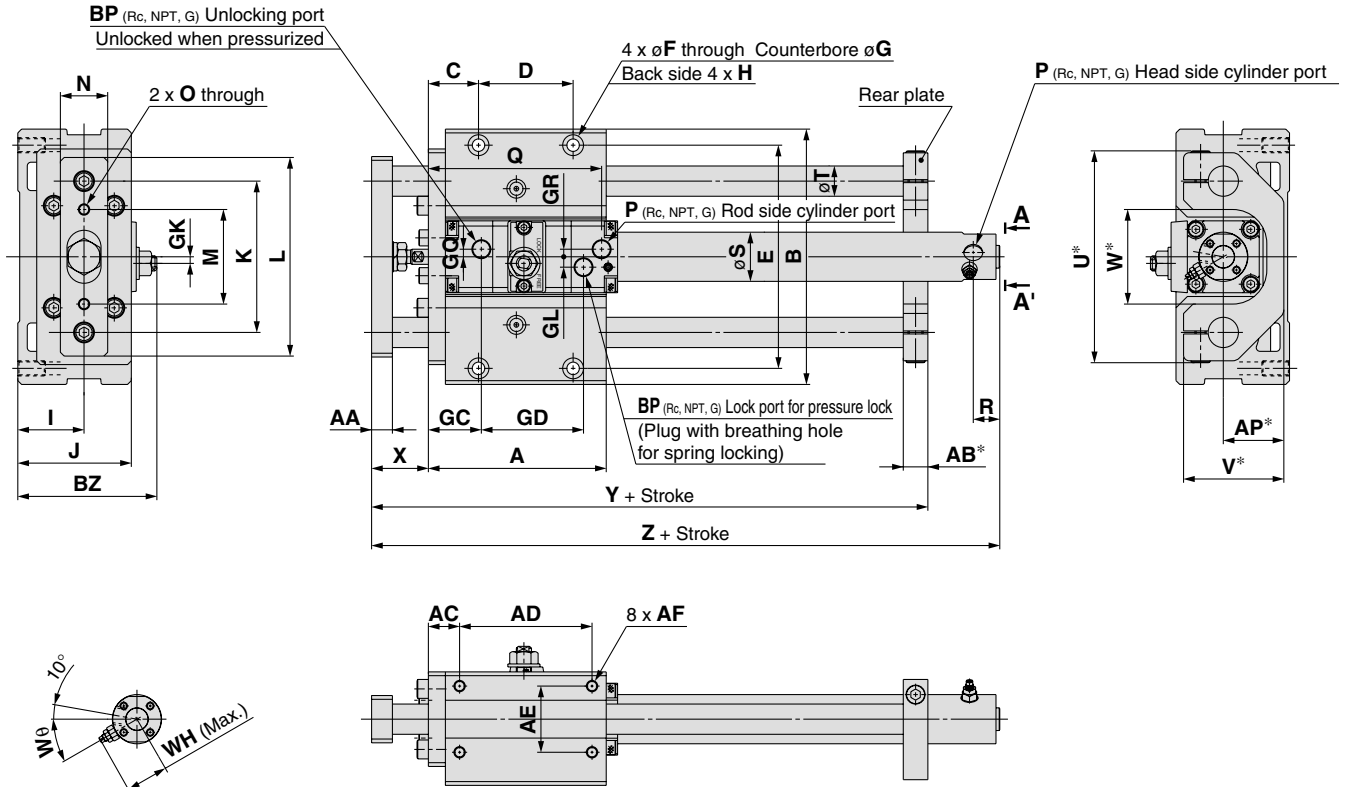

View A-A'

Standard Stroke

		(mm)																
Bore size (mm)	Stroke range (mm)	A	AA	AB	AC	AD	AE	AF	AP	B	BP ^{Note 3)}	BZ	C	D	E	F	G	GC
20	75, 100, 125, 150, 200	94	12	13	16.5	70	35	M6 x 1 depth 12	32	135	1/8	73.5	26.5	50	118	6.8	11 depth 8	28
25	75, 100, 125	104	16	16	19	75	40	M8 x 1.25 depth 16	37	160	1/8	86.5	31.5	50	140	8.6	14 depth 10	29
32	150, 200, 250	104	16	16	19	75	40	M8 x 1.25 depth 16	37	160	1/8	86.5	31.5	50	140	8.6	14 depth 10	30
40	300	142	19	19	22	110	45	M10 x 1.5 depth 20	42	194	1/8	95	37	80	170	10.5	17 depth 12	35

Bore size (mm)	GD	GK	GL	GQ	GR	H	I	J	K	L	M	N	O	P ^{Note 2)}	Q	R	S
20	54	3.5	5.5	4	4	M8 x 1.25 depth 14	35	60	80	105	50	25	M6 x 1	M5 x 0.8	94	12	26
25	62	4	9	7	7	M10 x 1.5 depth 18	40	70	95	125	60	32	M8 x 1.25	M5 x 0.8	104	12	31
32	62	4	9	7	7	M10 x 1.5 depth 18	40	70	95	125	60	32	M8 x 1.25	1/8	104	12	38
40	67	4	11	8	7	M12 x 1.75 depth 21	45	82.5	115	150	75	38	M8 x 1.25	1/8	115	12	47

Bore size (mm)	T	U	V	W	WH	Wθ	X	Y	Z
20	16	112	53	50	23	30°	30	146	182
25	20	132	63	60	25	30°	37	167	199
32	20	132	63	60	28.5	25°	37	167	202
40	25	162	73	70	33	20°	44	210	227

Without Rear Plate

Bore size (mm)	Y
20	129
25	146
32	146
40	191

Long Stroke

Bore size (mm)	Stroke range (mm)	R	Z
20	250 to 400	14	190
25	350 to 500	14	207
32	350 to 600	14	210
40	350 to 800	15	236

Note 1) Dimensions marked with "*" are not required for without rear plate.
 Note 2) For bore size 20 and 25, M5 x 0.8 is only available.
 Rc, NPT, G port are available for bore size with 32 or greater.
 Note 3) Rc, NPT, G port are available.



Dimensions

Front mounting flange: With rear plate

MLGC□F□□-□-R-□

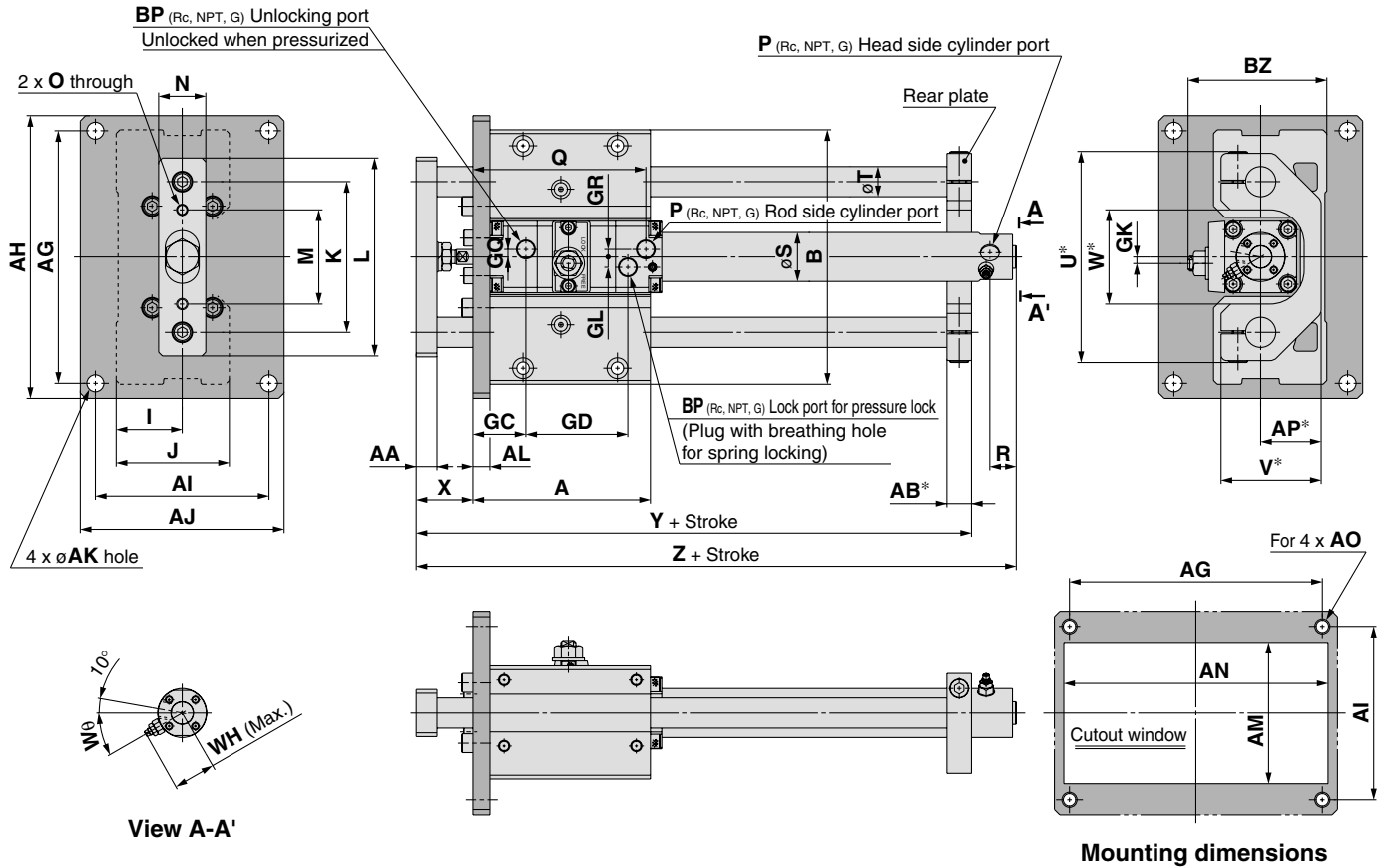

- CLJ2
- CLM2
- CLG1
- CL1
- MLGC**
- CNG
- MNB
- CNA
- CNS
- CLS
- CLQ
- RLQ
- MLU
- MLGP
- ML1C

Standard Stroke

Bore size (mm)	Stroke range (mm)	(mm)																			
		A	AA	AB	AG	AH	AI	AJ	AK	AL	AM	AN	AO	AP	B	BP ^{Note 3)}	BZ	GC	GD	GK	
20	75, 100, 125, 150, 200	94	12	13	134	150	92	108	9	9	75	140	M8	32	135	1/8	73.5	28	54	3.5	
25	75, 100, 125	104	16	16	160	176	110	125	9	9	88	165	M8	37	160	1/8	86.5	29	62	4	
32	150, 200, 250	104	16	16	160	176	110	125	9	9	88	165	M8	37	160	1/8	86.5	30	62	4	
40	300	142	19	19	190	210	115	135	11	12	96	200	M10	42	194	1/8	95	35	67	4	

Bore size (mm)	GL	GQ	GR	I	J	K	L	M	N	O	P ^{Note 2)}	Q	R	S	T	U	V	W
20	5.5	4	4	35	60	80	105	50	25	M6 x 1	M5 x 0.8	94	12	26	16	112	53	50
25	9	7	7	40	70	95	125	60	32	M8 x 1.25	M5 x 0.8	104	12	31	20	132	63	60
32	9	7	7	40	70	95	125	60	32	M8 x 1.25	1/8	104	12	38	20	132	63	60
40	11	8	7	45	82.5	115	150	75	38	M8 x 1.25	1/8	115	12	47	25	162	73	70

Bore size (mm)	WH	W θ	X	Y	Z
20	23	30°	30	146	182
25	25	30°	37	167	199
32	28.5	25°	37	167	202
40	33	20°	44	210	227

Without Rear Plate

Bore size (mm)	Y
20	129
25	146
32	146
40	191

Long Stroke

Bore size (mm)	Stroke range (mm)	R	Z
20	250 to 400	14	190
25	350 to 500	14	207
32	350 to 600	14	210
40	350 to 800	15	236

Note 1) Dimensions marked with "*" are not required for without rear plate.

Note 2) For bore size 20 and 25, M5 x 0.8 is only available.

Rc, NPT, G port are available for bore size 32 or greater.

Note 3) Rc, NPT, G port are available.

- D-□
- X□
- Individual
- X□

Series MLGC

Auto Switch Proper Mounting Position (Detection at Stroke End) and Its Mounting Height

**D-A9 type,
D-M9, M9□W type**

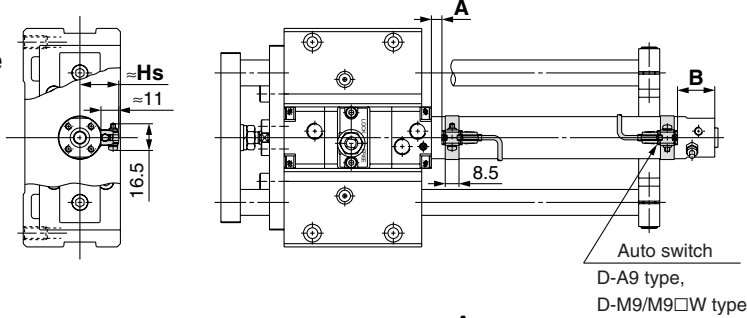

**D-C7, C8 type,
D-H7 type**

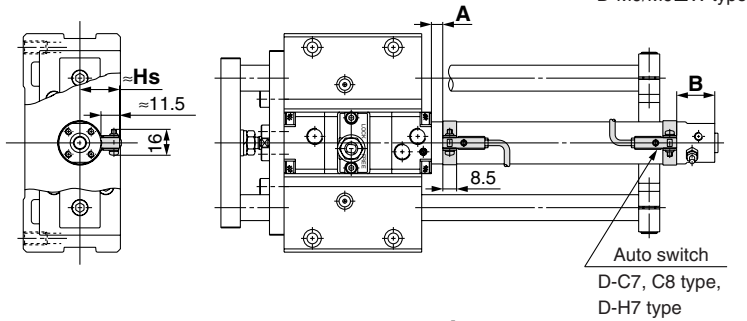

**D-B5, B6 type,
D-G5, K5 type**

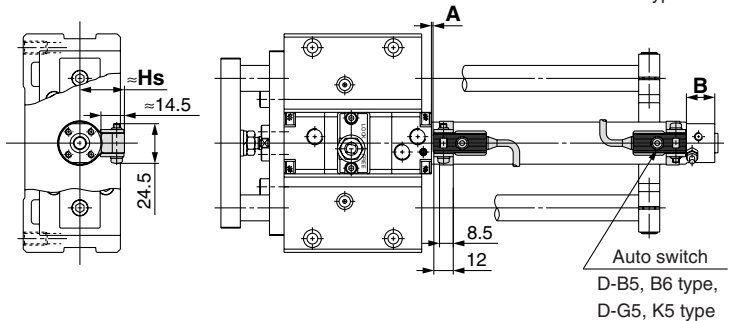

**D-B7, B8 type,
D-G7, K7 type**

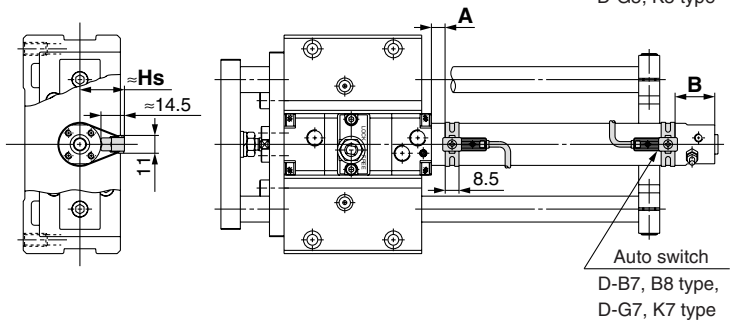

Auto Switch Proper Mounting Position

(mm) Auto Switch Mounting Height (mm)

Auto switch model	D-A9□		D-M9□ D-M9□W		D-B7□ D-B80 D-B73C D-B80C D-G79 D-K79		D-C7□ D-C80 D-C73C D-C80C		D-H7□ D-H7C D-H7□W D-H7BAL D-H7NF		D-B5□ D-B64		D-B59W		D-G5□ D-K59 D-G5NTL D-G5□W D-K59W D-G59F D-G5BAL		Auto switch model	D-A9□ D-M9□ D-M9□W		D-C7/C8 D-H7□ D-H7NF D-H7BAL		D-C73C D-C80C		D-B7/B8 D-B73C D-B80C D-K59W D-G5NTL D-B5/B6 D-B59W D-G5BAL D-G59F	
	A	B	A	B	A	B	A	B	A	B	A	B	A	B	A	B		Applicable bore size	Hs	Hs	Hs	Hs			
20	6.5	23 (31)	10.5	27 (35)	8	24.5 (32.5)	7	23.5 (31.5)	6	22.5 (30.5)	1	17.5 (25.5)	4	20.5 (28.5)	2.5	19 (27)	20	24	24.5	27	27.5				
25	6.5	23 (31)	10.5	27 (35)	8	24.5 (32.5)	7	23.5 (31.5)	6	22.5 (30.5)	1	17.5 (25.5)	4	20.5 (28.5)	2.5	19 (27)	25	26.5	27	29.5	30				
32	6.5	25 (33)	10.5	29 (37)	8	26.5 (34.5)	7	25.5 (33.5)	6	24.5 (32.5)	1	19.5 (27.5)	4	22.5 (30.5)	2.5	21 (29)	32	30	30.5	33	33.5				
40	9.5	28 (37)	13.5	32 (41)	11	29.5 (38.5)	10	28.5 (37.5)	9	27.5 (36.5)	4	22.5 (31.5)	7	25.5 (34.5)	5.5	24 (33)	40	34.5	35	37.5	38				

* (): Values for long strokes.

Note) When setting an auto switch, confirm the operation and adjust its mounting position.

Minimum Stroke for Auto Switch Mounting

n: Number of auto switches (mm)

Auto switch model	Number of auto switches mounted		
	With 1 pc.	With 2 pcs.	With n pcs.
		Same surface	Same surface
D-A9□ D-M9□ D-M9□W	10	45 <small>Note)</small>	45 + 45 (n-2)
D-C7□ D-C80	10	50	50 + 45 (n-2)
D-H7□ D-H7□W D-H7BAL D-H7NF	10	60	60 + 45 (n-2)
D-C73C/C80C D-H7C D-B73C/B80C D-K79C	10	65	65 + 50 (n-2)
D-B5□ D-B64 D-G5□ D-K59□	10	75	75 + 55 (n-2)
D-B59W	10	75	75 + 55 (n-2)
D-B7□ D-B80 D-G79 D-K79	10	45	50 + 45 (n-2)

Note) Caution when two D-A93, M9□, M9□W auto switches are used.

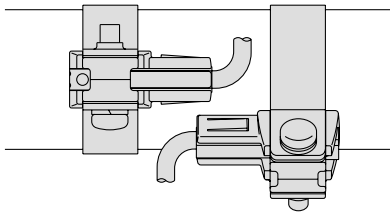
Auto switch model	With two auto switches	
	Same surface	
		
	The auto switches are offset (one auto switch is displaced more around the outside of the cylinder tube) so that the auto switches and lead wires do not interfere with each other.	
D-A93	Less than 50 stroke	
D-M9□ D-M9□W	Less than 55 stroke	

CLJ2

CLM2

CLG1

CL1

MLGC

CNG

MNB

CNA

CNS

CLS

CLQ

RLQ

MLU

MLGP

ML1C

D-□

-X□

Individual
-X□

Operating Range

Auto switch model	Bore size (mm)			
	20	25	32	40
D-A9□	7	6	8	8
D-M9□	5	5.5	5	5.5
D-M9□W				
D-B7□/B80	8	10	9	10
D-B73C/B80C				
D-C7□/C80	8	10	9	10
D-C73C/C80C				
D-B5□/B64	8	10	9	10
D-B59W				
D-G79/K79/K79C	8	10	9	10
D-H7BAL				
D-H7□/H7□W/H7NF	4	4	4.5	5
D-H7C	7	8.5	9	10
D-G5□/K59	4	4	4.5	5
D-G5□W/K59W				
D-G5NTL/G5BAL				
D-G59F	5	5	5.5	6
D-G5NBL	35	40	40	45

* Since this is a guideline including hysteresis, not meant to be guaranteed.
(Assuming approximately ±30% dispersion.)
There may be the case it will vary substantially depending on an ambient environment.

Auto Switch Mounting Bracket Part No.

Auto switch model	Bore size (mm)			
	ø20	ø25	ø32	ø40
D-A9□	Note) ①BMA2-020 ②BJ3-1	Note) ①BMA2-025 ②BJ3-1	Note) ①BMA2-032 ②BJ3-1	Note) ①BMA2-040 ②BJ3-1
D-M9□				
D-M9□W				
D-C7□/C80	BMA2-020	BMA2-025	BMA2-032	BMA2-040
D-C73C/C80C				
D-H7□/H7C				
D-H7□W				
D-H7BAL				
D-H7NF				
D-B5□/B64	BA-01	BA-02	BA-32	BA-04
D-B59W				
D-G5□/K59				
D-G5□W/K59W				
D-G5BAL				
D-G59F				
D-G5NTL				
D-G5NBL				
D-B7□/B80	BM1-01	BM1-02	BM1-32	BM1-04
D-B73C/B80C				
D-G79/K79				
D-K79C				

Note) Two types of the auto switch brackets are used as a set.

[Mounting screws set made of stainless steel]

The following set of mounting screws made of stainless steel is also available. Use it in accordance with the operating environment. (Please order the auto switch mounting bracket separately, since it is not included.)

BBA3: For D-B5, B6, G5, K5 type

BBA4: For D-C7, C8, H7 type

Note) Refer to pages 1813 and 1814 for the details of BBA3 and BBA4.

"D-H7BAL/G5BAL" switch is set on the cylinder with the stainless steel screws above when shipped.

When only a switch is shipped independently, "BBA3" or "BBA4" screws are attached.

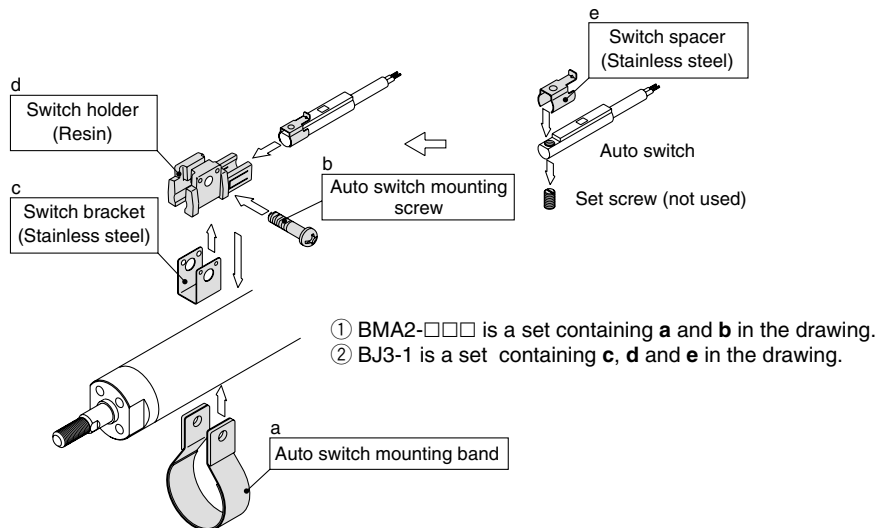

Other than the applicable auto switches listed in "How to Order", the following auto switches can be mounted.
For detailed specifications, refer to pages 1719 to 1827.

Auto switch type	Model	Electrical entry (Direction)	Features
Reed	D-C73, C76, B73, B73C, B76	Grommet (in-line)	—
	D-C80, B80C		Without indicator light
	D-B53		—
Solid state	D-H7A1, H7A2, H7B, G79, K79, K79C		—
	D-H7NW, H7PW, H7BW		Diagnostic indication (2-color indication)
	D-G5NTL		With timer

* With pre-wired connector is available for solid state auto switches. For details, refer to pages 1784 and 1785.

* Normally closed (NC = b contact), solid state auto switches (D-F9G, F9H type) are also available. For details, refer to page 1746.

* Wide range detection type, solid state auto switch (D-G5NBL type) is also available. For details, refer to page 1776.



Series MLGC Specific Product Precautions

Be sure to read before handling.

Refer to front matters 42 and 43 for Safety Instructions and pages 3 to 11 for Actuator and Auto Switch Precautions.

Mounting and Adjustment

Warning

1. Installing a protective cover (In the case of rear plate)

During mounting, handling and operation, the rear plate makes reciprocating movements. Therefore, pay careful attention not to insert your hand, etc., between the cylinder and the rear plate.

When you are going to fit this product to the outside of your equipment, take preventative measures such as installing a protective cover.

Protective cover installation example

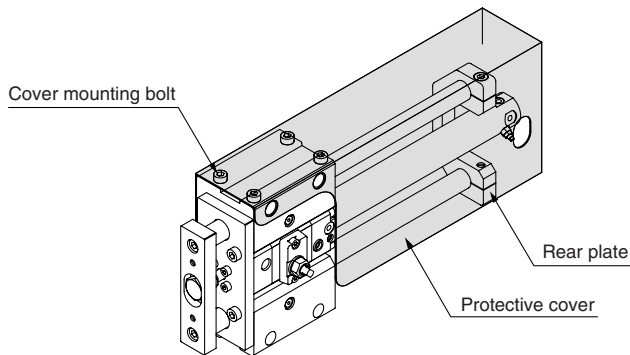
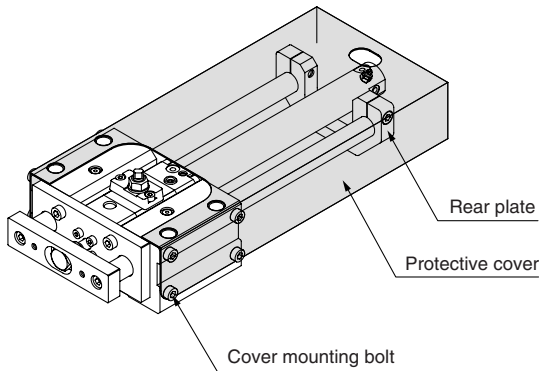

Caution on Handling the Fine Lock Cylinder

Caution

1. For details, make sure to refer to "Fine Lock Cylinder (CLG1 series)" on pages 596 to 599.

Caution

1. Use caution that no scratch or dent will be given to the slide part of the guide rod.

Because the outer circumference of the guide rod is manufactured with precise tolerances, even a slight deformation, scratch, or gouge can lead to faulty operation or reduced durability.

2. When fitting the guide body, use the guide body which has high flatness of the fitting surface.

If the guide rod has twisted, operation resistance will become abnormally higher and the bearing will wear at an early stage, thereby resulting in poor performance.

3. Allow an ample space around the cylinder.

Ensure enough clearance around the cylinder to allow for unobstructed maintenance and inspection work.

4. Do not adjust the rod stroke by moving the rear plates.

The resulting impact cannot be absorbed easily, the stroke position cannot be maintained, and faulty operation may ensue since the rear plate comes into direct contact with the guide body or the rod cover.

5. Lubrication

To prevent foreign particles from mixing with the grease, use a grease applicator that has a check valve. Use a high-quality lithium soap-based no. 2 grease.

6. Mounting orientation

For ceiling mount (opening of the rear plate face downwards), the base cylinder head end and the rear plate may interfere due to the deflection of the guide rod.

CLJ2

CLM2

CLG1

CL1

MLGC

CNG

MNB

CNA

CNS

CLS

CLQ

RLQ

MLU

MLGP

ML1C

D-□

-X□

Individual
-X□