

# IO-Link Compatible 3-Screen Display Digital Gap Checker

New



**Displayed value**

Converted value of the gap distance (Reference)  
16-bit data

**Monitoring the placement condition of the workpiece**  
Indicates failure/abnormality

**Supply pressure value**

Product supply pressure (SUP)  
16-bit data

**Outlet pressure value**

Detection nozzle side pressure (Back pressure)  
16-bit data

## NPN/PNP Switch Function

Both NPN and PNP are available.

The number of stock items can be reduced.



## 3-Screen Display (Setting)

Upper 4-digit Lower 4-digit x 2-screen

Keylock indicator

IO-Link status indicator light

OUT1 output indicator

OUT2 output indicator



Upper  
Main screen

Lower  
Sub screen

## Window Comparator Type

The gap range is adjustable.

$50 \leq \text{Pass} \leq 70$

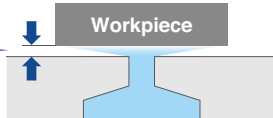

Existing

Checked only "Placed" or "Not placed"

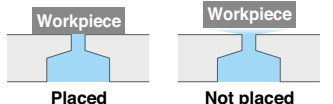

## Zero cut-off range can be changed.

The lower limit of the display/setting range has been extended.

Model	Distance [mm]					
	0	0.02	0.05	0.15	0.30	0.50
ISA3-F type	[Bar chart showing range from 0.02 to 0.05]					
ISA3-G type	[Bar chart showing range from 0.02 to 0.30]					
ISA3-H type	[Bar chart showing range from 0 to 0.30]					

Adjustable to 0

mm ÷ 25.4 = Inches

# ISA3-L Series



NAS100-125A

# Double sensor providing improved preventive and predictive maintenance (IoT) based on IO-Link

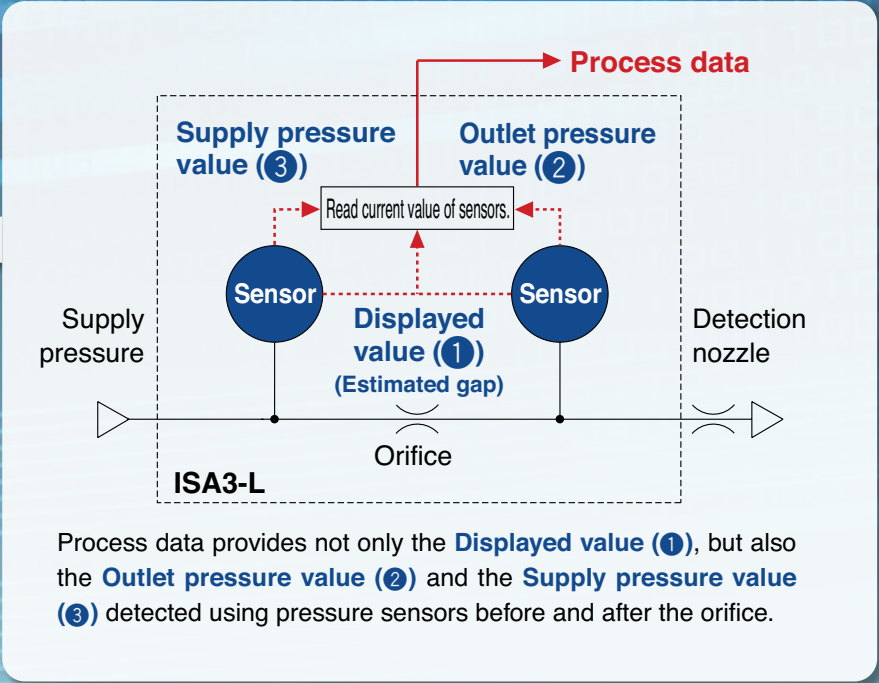
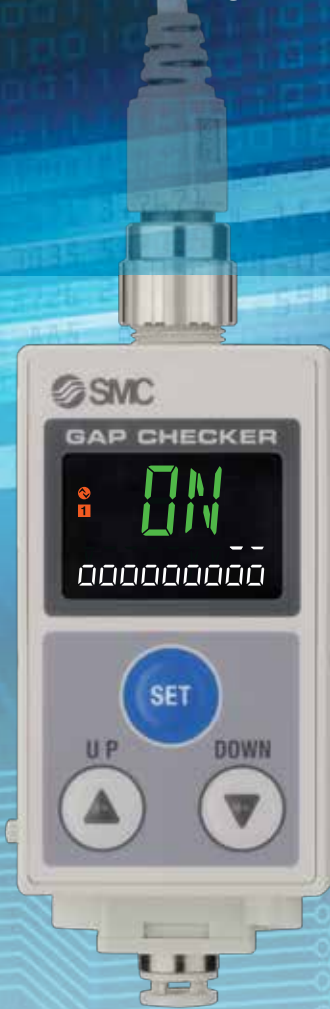

Process data provides not only the **Displayed value (1)**, but also the **Outlet pressure value (2)** and the **Supply pressure value (3)** detected using pressure sensors before and after the orifice.

### Process Data

Item	Gap size (Reference): 16 Bit signed integer																
Bit offset	63	62	61	60	59	58	57	56	55	54	53	52	51	50	49	48	
Item	Supply pressure value: 16 Bit signed integer																
Bit offset	47	46	45	44	43	42	41	40	39	38	37	36	35	34	33	32	
Item	Outlet pressure value: 16 Bit signed integer																
Bit offset	31	30	29	28	27	26	25	24	23	22	21	20	19	18	17	16	
Item	Error diagnosis	0							Pressure diagnosis	0		Outlet side SW2	Outlet side SW1	Supply side SW2	Supply side SW1	Distance detection SW2	Distance detection SW1
Bit offset	15	14	13	12	11	10	9	8	7	6	3	2	5	4	1	0	

**Diagnosis item**

- Abnormal temperature
- Display pressure range has exceeded the lower limit
- Internal product malfunction
- Outside of zero-clear range

**Diagnosis item**

- Detected pressure: Less than -20 kPa

### Example of Detection Applications Using the Switching Outputs and Value

Setting example	Outlet pressure value		Supply pressure value		Displayed value (Gap size)		Diagnosis item
	SW2	SW1	SW2	SW1	SW2	SW1	
	En_2: 5.0	EP1L: 25.0 EP1H: 50.0	SP_2: 200.0	Sn_1: 100.0	n_2: 150	n_1: 50	
Mode	Hysteresis	Window comparator	Hysteresis	Hysteresis	Hysteresis	Hysteresis	
Setting contents	Turns ON at 5 kPa or less	Turns ON at 25 to 50 kPa	Turns ON at 200 kPa or more	Turns ON at 100 kPa or less	Turns ON at 150 μm or less	Turns ON at 50 μm or less	
Output status	—	—	—	—	○	○	Confirmation of close contact: 50 μm or less
	—	—	—	—	○	—	Confirmation of approximate contact: 150 μm or less
	—	—	—	○	—	—	Insufficient supply pressure: 100 kPa or less
	—	○	—	—	—	—	Excessive supply pressure: 200 kPa or more
	○	—	—	—	—	—	Detection nozzle clogging Orifice clogging

○: The corresponding bit in the process data is "1:ON" —: The corresponding bit in the process data is "0:OFF" or not determined



# Process data provides (1) Displayed value, (2) Outlet pressure and (3) Supply pressure value.

Not only the displayed value, but also the pressure value (supply pressure, outlet pressure) which affect the detection can be transmitted in real time.



The displayed value is converted value of the gap distance and is a guideline.

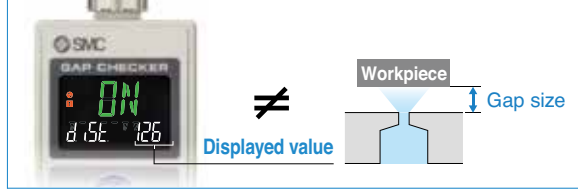

The relationship between the displayed value (gap distance guideline) and detection nozzle clogging/orifice clogging

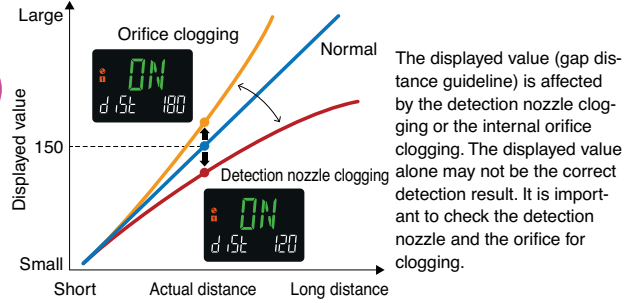

The displayed value (gap distance guideline) is affected by the detection nozzle clogging or the internal orifice clogging. The displayed value alone may not be the correct detection result. It is important to check the detection nozzle and the orifice for clogging.

## Monitoring of the outlet pressure value

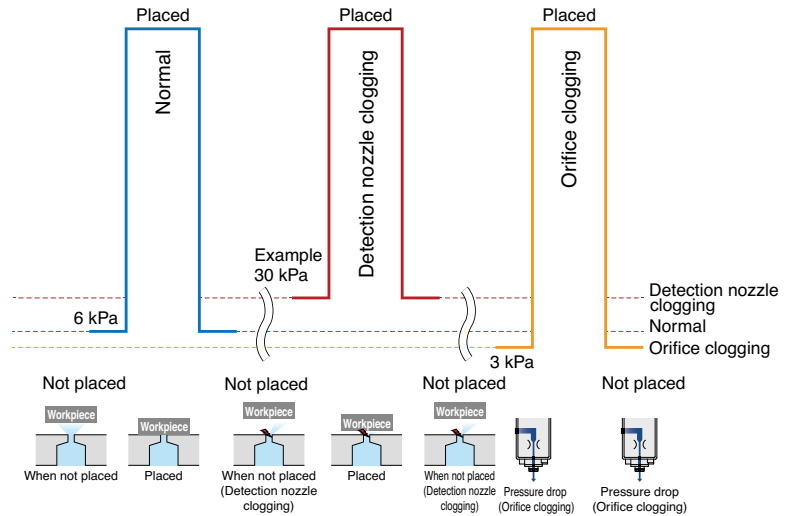
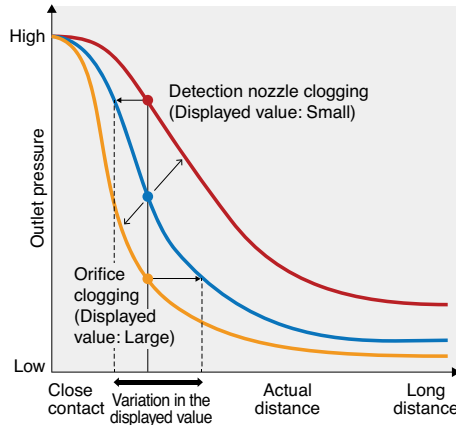

The displayed value varies if the detection nozzle or internal orifice is clogged. It is possible to detect clogging by monitoring the outlet pressure during workpiece transfer (the workpiece is not placed).

## Monitoring of the supply pressure value

Change of the outlet pressure when the supply pressure changes

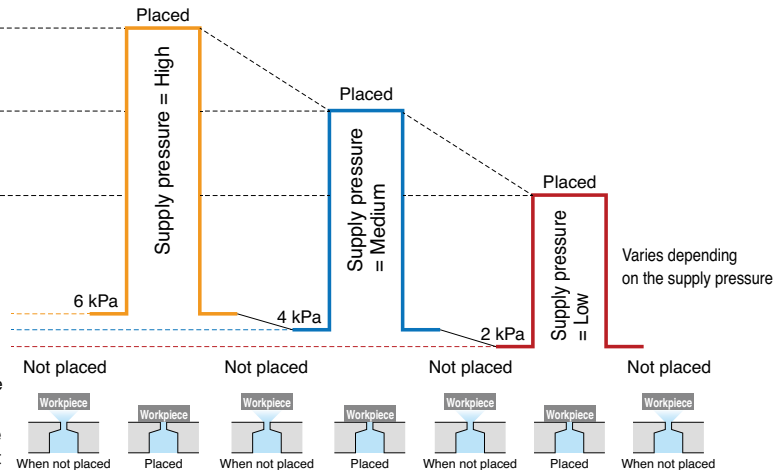
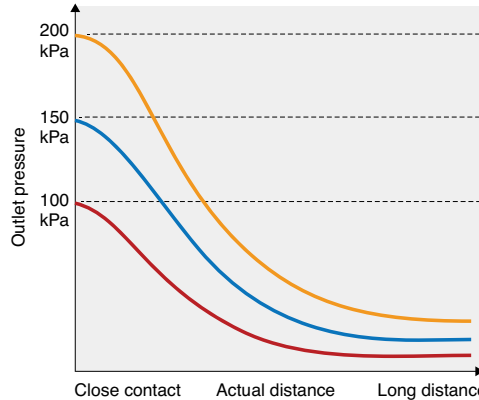

The outlet pressure while the workpiece is being transferred (not placed) also varies depending on the supply pressure. The supply pressure and the outlet pressure need to be monitored simultaneously.

Unit conversion table is located inside back cover.



IO-Link is an open communication interface technology between the sensor/actuator and the I/O terminal that is an international standard, IEC61131-9.

## Visualization of operation/equipment status Remote monitoring and control by communication

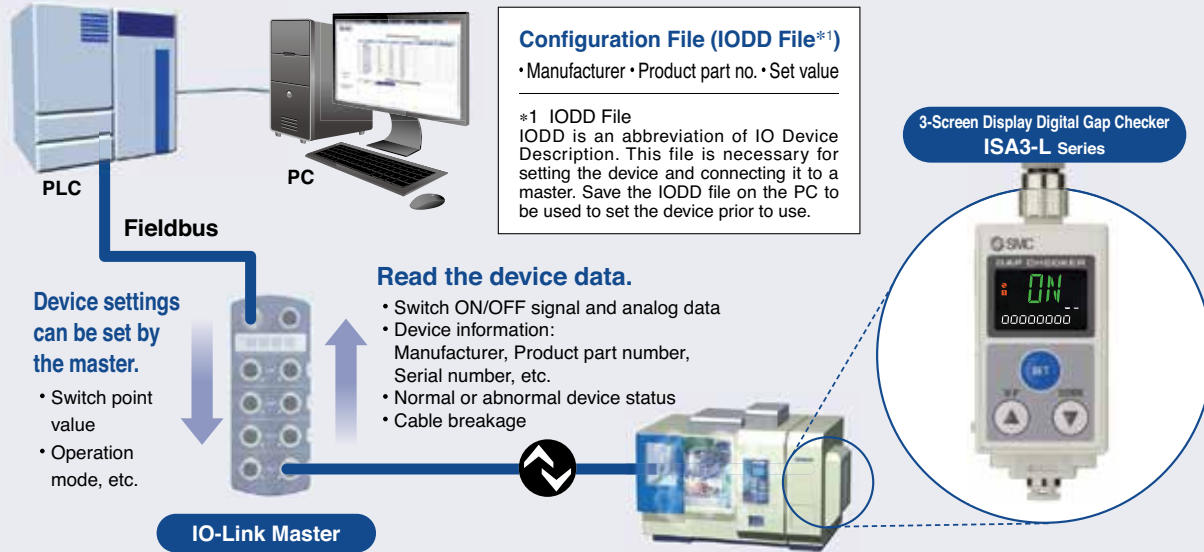

### Automatic setting function [Data storage function]

When replacing the sensor with the same type (the same device ID), the parameters (set values) stored in the IO-Link master are automatically copied (set) to the new sensor.



Displays the output communication status and indicates the presence of communication data



### Operation and Display

Communication with master	IO-Link status indicator light	Status	Screen display *2	Description	
Yes	ON *1	Normal	Operate	MODE oPE	Normal communication status (readout of measured value)  At the start of communication
			Start up	MODE StRt	
			Preoperate	MODE PrE	
No	Flashing *1 (IO-Link mode)	Abnormal	Version does not match	Er 15 V 10	IO-Link version does not match that of the master. The master uses version 1.0. * The applicable IO-Link version is 1.1.
		Abnormal	Communication disconnection	MODE oPE MODE StRt MODE PrE	Normal communication was not received for 1 second or longer.
	OFF	SIO mode	MODE S iO	General switch output	

\*1 In IO-Link mode, the IO-Link indicator is ON or flashes. \*2 When the sub screen is set to Mode  
\* "ModE LoC" is displayed when the data storage lock is enabled. (Except for version mismatch or when in SIO mode)



## Sub display improved for ease of use

### Pressure resolution improved

Values can be checked up to 0.1 kPa using 4-digits display.



### Line name display

Required characters string of 4 digits can be entered (up to 9 digits can be input) using a dual display.

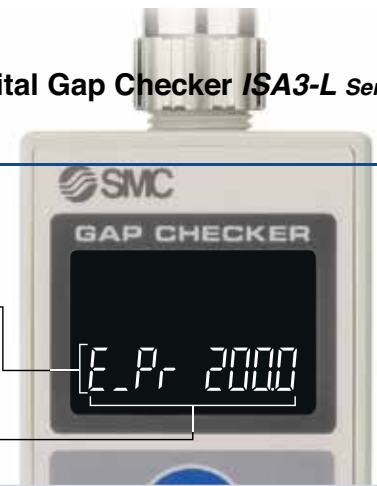

### Level meter digits increased

6 digits → 9 digits



Status can be checked in more detail due to the increase of the level meter digits.

IO-Link Compatible *ISA3-L Series*

Level meter digits increased: **9 digits**

*ISA3 Series*

Number of level meter digits: **6 digits**

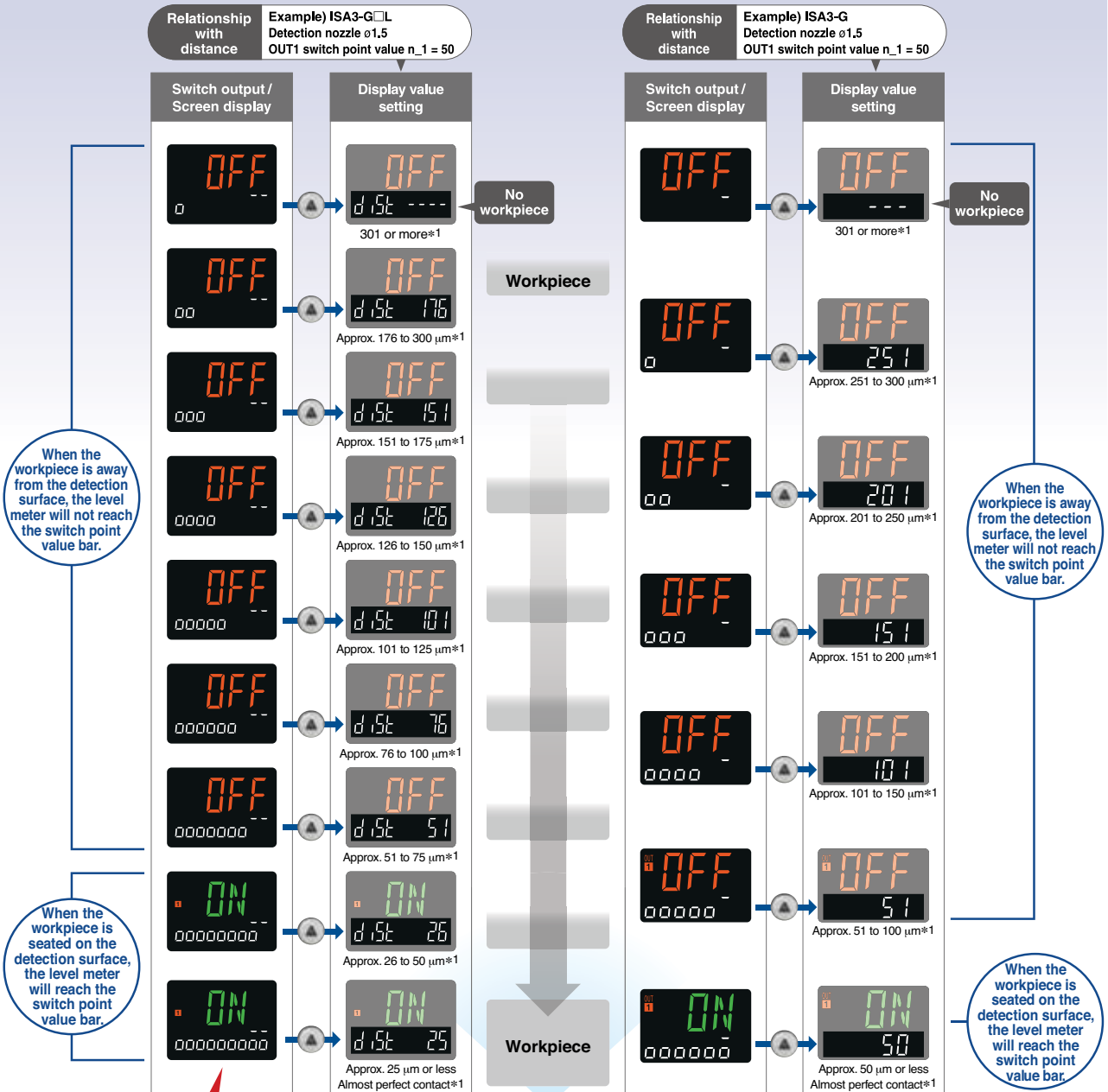

The number of level meter symbols changes depending on the clearance between the workpiece and the detection surface. Even clearances which cannot be visually confirmed are indicated on the display.

\*1 The displayed value (estimated gap distance) will vary depending on individual product differences and nozzle machining dimensions.

## 3-Step Setting (Switch Point Change Mode)

- Simple setting of the switch point value (point at which the clearance reaches the switch point value)

**Snap shot function**  
Pressing the  $\odot$  and  $\ominus$  buttons simultaneously for a minimum of 1 second then releasing the buttons when the displayed switch point value disappears will make the switch point the same as the current displayed value.

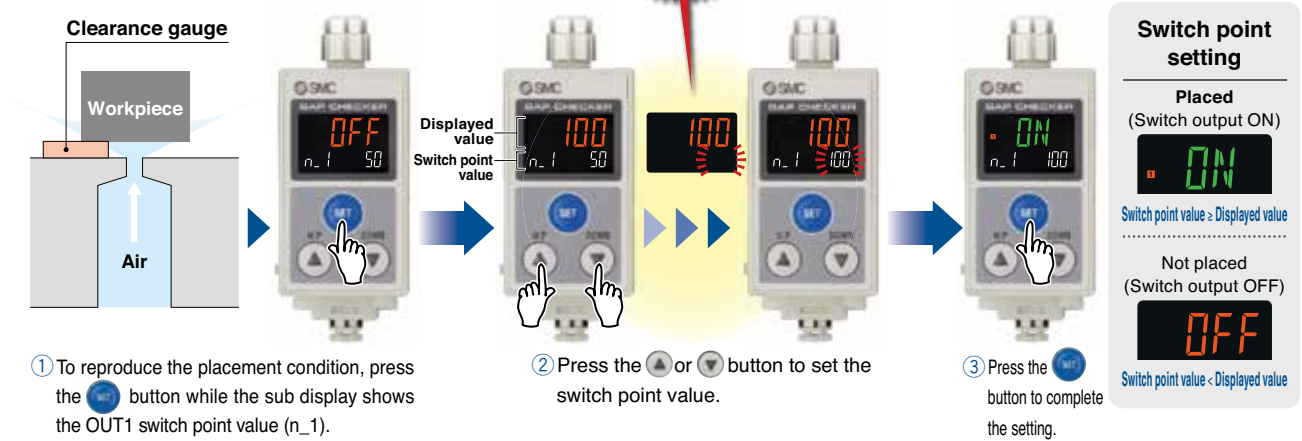

- To reproduce the placement condition, press the  $\odot$  button while the sub display shows the OUT1 switch point value (n\_1).
- Press the  $\uparrow$  or  $\downarrow$  button to set the switch point value.
- Press the  $\odot$  button to complete the setting.

\* Operation is different from products which are not IO-Link compliant (1 output, 2 outputs type).

## 3-Screen Digital Display

- The seating condition can be checked at a glance. The sub screen can display 1 of 12 display options.

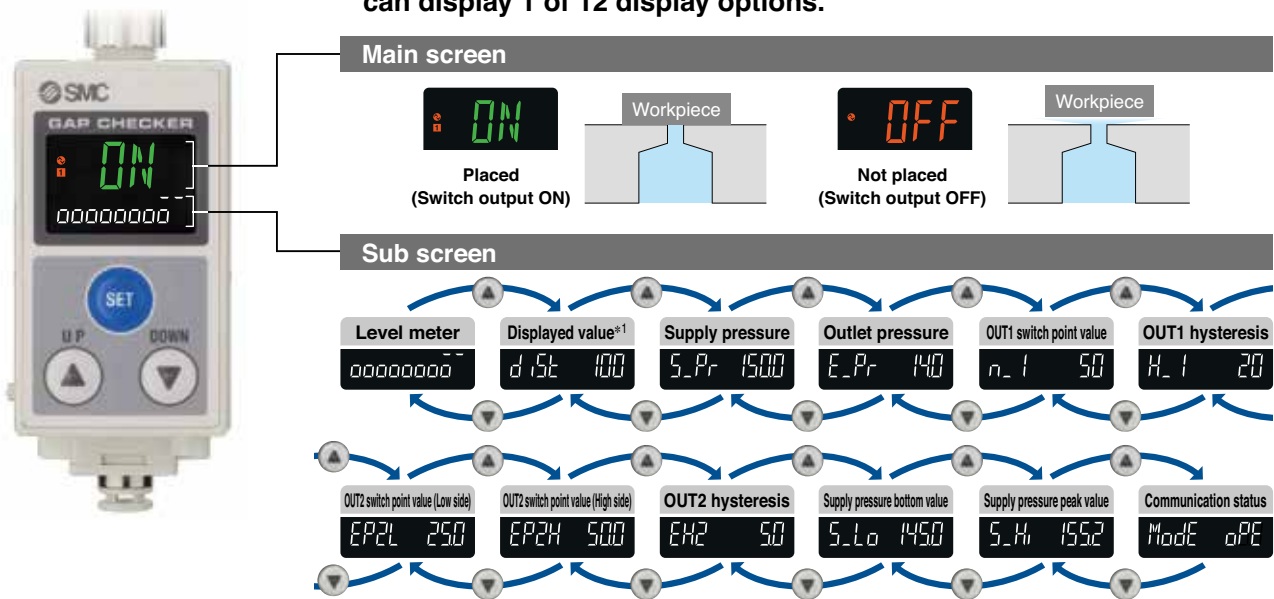

\*1 The displayed value is a reference value obtained by converting the distance between the workpiece and the detection surface into a digital numerical value. It is not displayed in units. For details, refer to the Relationship Between Displayed Value and Distance on page 18.

## Rated Distance Range: 3 types are available.

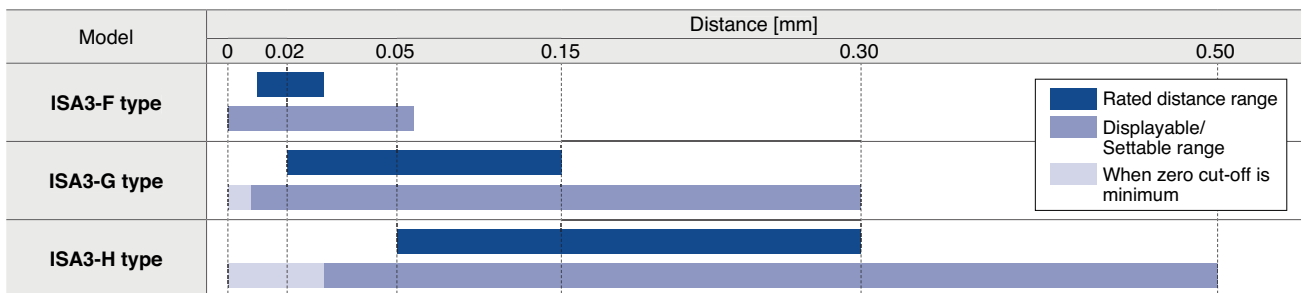

### 3 Setting Modes

Select the setting mode that best meets your needs.

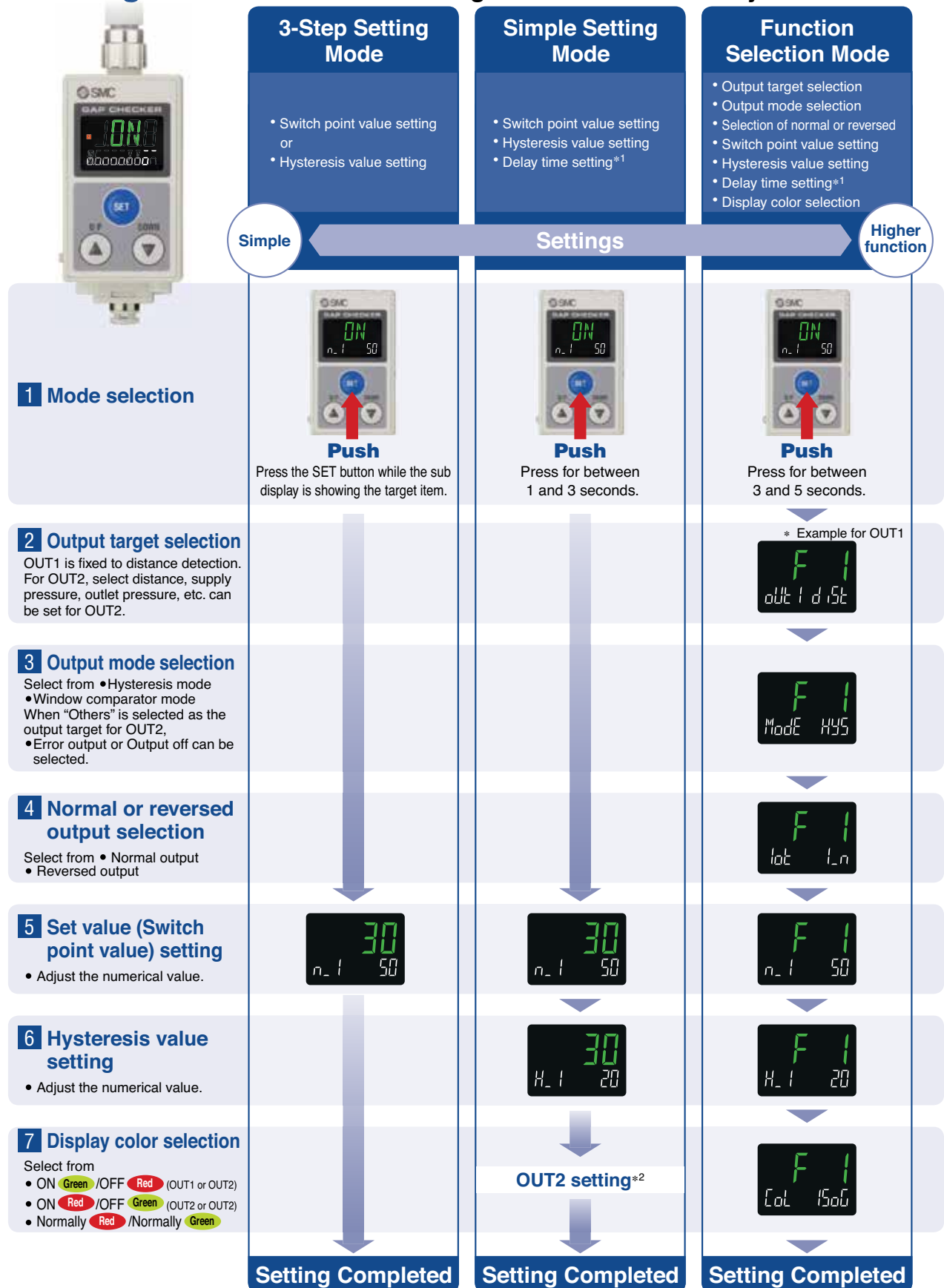

\*1 Available when OUT2 is not set for "distance." It can be set in the next step of the Hysteresis value setting.

\*2 Refer to the Operation Manual for details on setting the OUT2.



## 2 Outputs Type • (1) Displayed value, (2) Outlet pressure value, and (3) Supply pressure value can be selected in OUT2.



The pressure and gap size are detected by the pressure sensors at the front and back of the orifice before output.

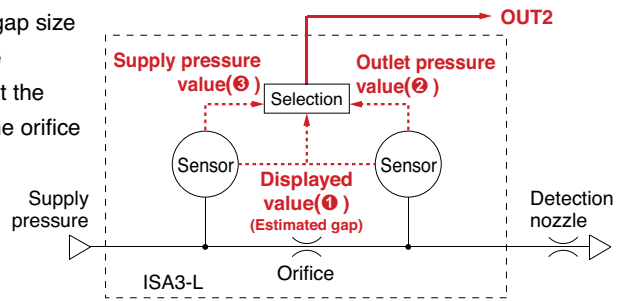

## Monitoring of the Outlet Pressure Value (2)

- **OUT2 detection of rising pressure when a workpiece is not placed that signifies detection nozzle clogging.**

Only nozzle clogging is detected by the window comparator mode and setting the response time.

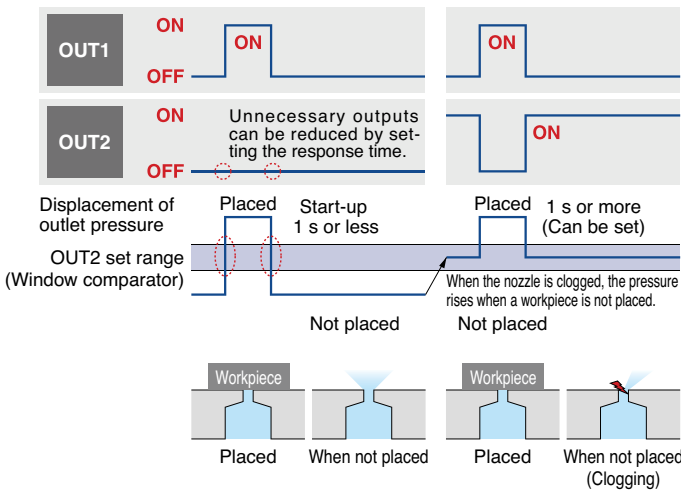

- **Can discern between 2 different types of workpiece**

Can detect raw material workpieces and defective workpieces via the **pressure (OUT2)**

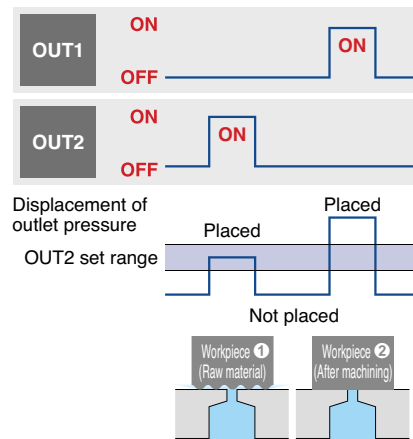

## Monitoring of the Displayed Value (Gap Size) (1)

- **Can discern between 2 different types of workpiece**

Can detect the difference between raw material workpieces and defective workpieces via the **gap size**

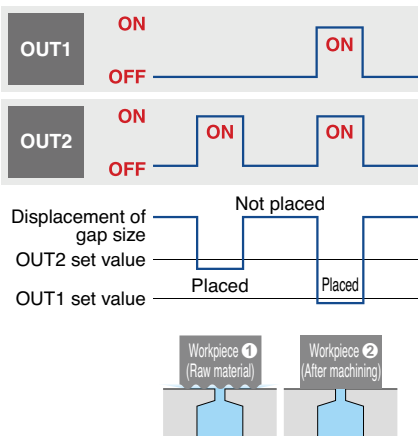

## Monitoring of the Supply Pressure Value (3)

- **Detection of rated pressure range via OUT2**

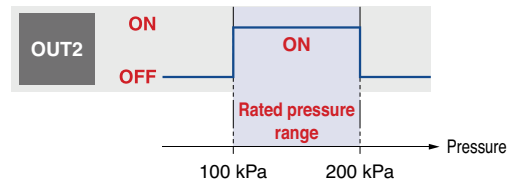

## Improved Environmental Resistance

### • Easier maintenance

The internal orifice part can be removed for cleaning. It is not necessary to remove the piping or metal connection fitting for cleaning even when the product is installed in the user's equipment.



\* Once the orifice has been removed, the switch point will need to be set again.

### • Measures against drainage

**Drainage resistance: increased by 10 times or more**

\* Based on SMC's specific testing conditions (Oil proof test)  
\* Compared with the ISA2

### • Withstand pressure increased by

**Max.: 600 kPa**

3 times\*<sup>1</sup>  
compared with the ISA2

\*<sup>1</sup> Compared with the ISA2 with a 0.2 MPa pressure gauge

### High-pressure flushing

\* The switch output will be OFF during flushing.

## Noise reduction, Energy saving, Measures against clogging

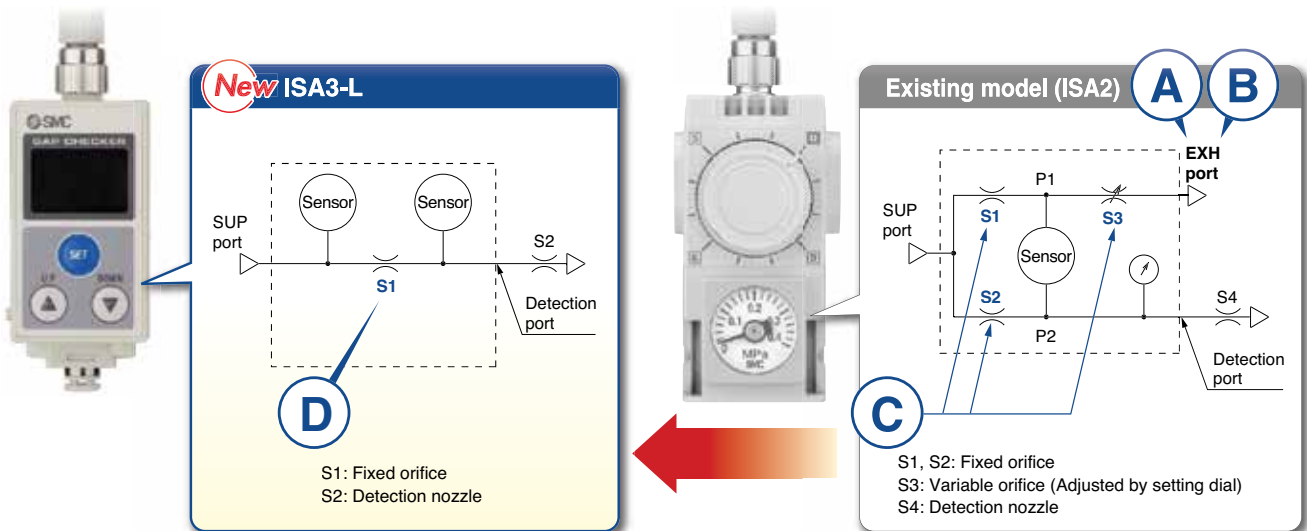

### A Exhaust noise: **Zero**

#### Noise reduction

The existing model (ISA2) needs to exhaust air from the exhaust port due to its bridge circuit. However, the ISA3 does not exhaust air from the product body. This reduces noise considerably compared with the existing model.

### B Air consumption: **60% reduction**\*<sup>1</sup>

#### Energy saving

The new detection principle eliminates the need for air to be exhausted from the product. This makes the flow consumption 0 L/min when a workpiece is seated. The result is a great reduction in air consumption compared with the existing model.

\*<sup>1</sup> Conditions: Unseated for 5 seconds and seated for 20 seconds (For the G type)

### C Number of orifices: **3 → 1**

#### Measures against clogging

By reducing the number of internal orifices from 3 to 1, there is less possibility of fluctuations in the output due to clogging. By removing the setting dial for S3, fluctuations in the detection distance can be prevented.

### D Orifice area ratio: **68% increase**\*<sup>1</sup>

#### Measures against clogging

A larger orifice area lowers the possibility of clogging. However, even if the orifice does become clogged with foreign matter, the product construction allows for the internal orifice to be removed for cleaning.

\*<sup>1</sup> Excludes the F type

## Compact & Lightweight

- Volume: **40% reduction**

Weight: **55% reduction**

(Comparison between the ISA3-GC and the existing model ISA2 with One-touch fitting)

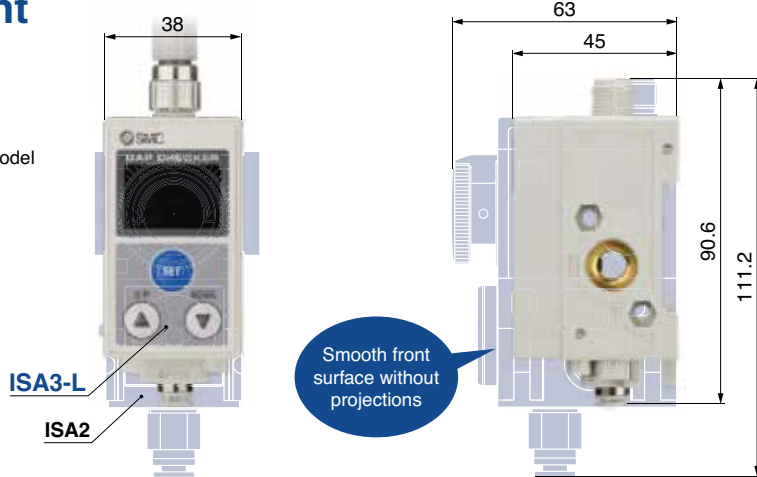

## Space saving and man-hour reduction by centralized lead wires

- Installation space: **30 mm reduction**

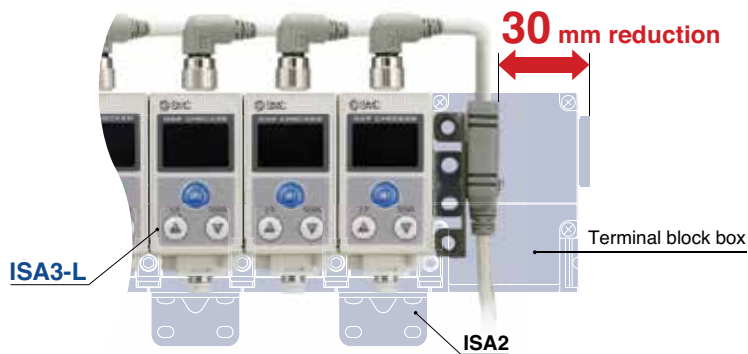

- Requires less wiring labor

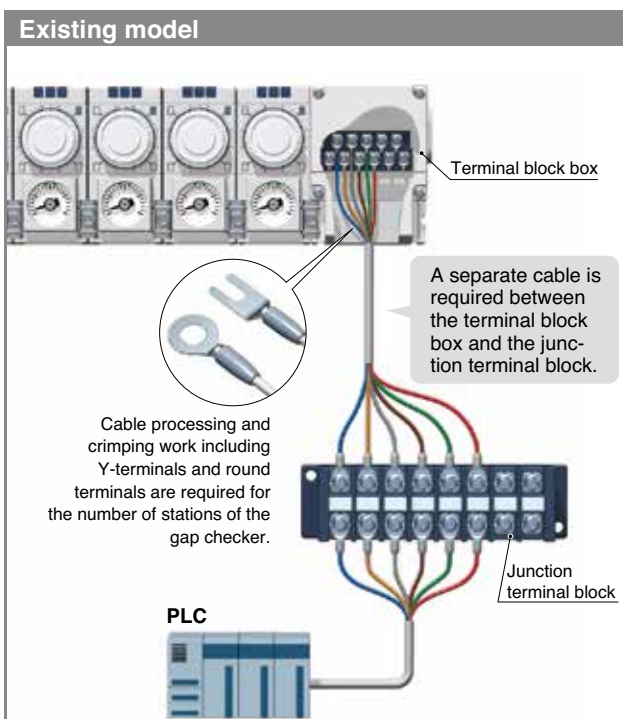
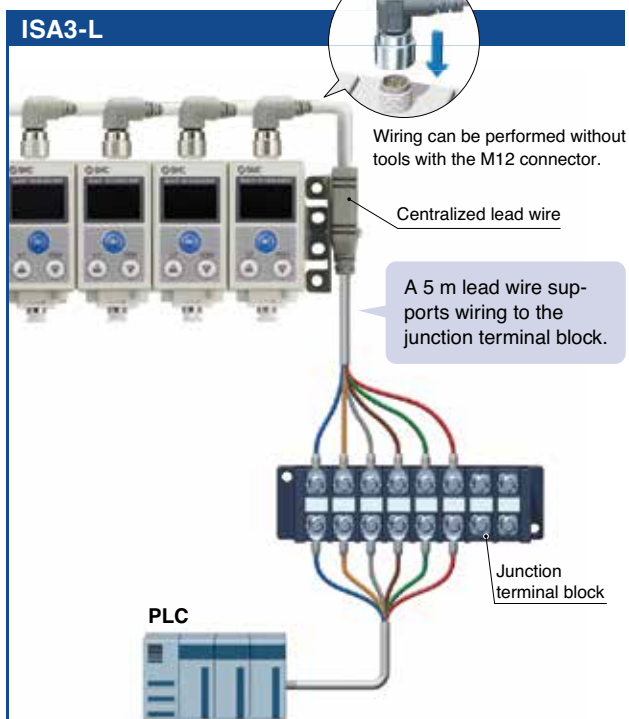



## Keylock Function

- A key LED turns ON when the product is locked and button operation is disabled to prevent unintentional changes to set values.

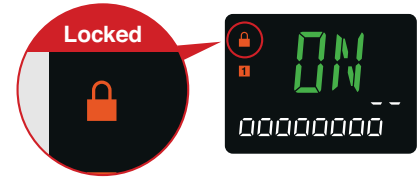

## Piping Variations

Piping specification: C type



Piping specification: F type



## Mounting

Bracket



DIN rail



## Manifold

With control unit

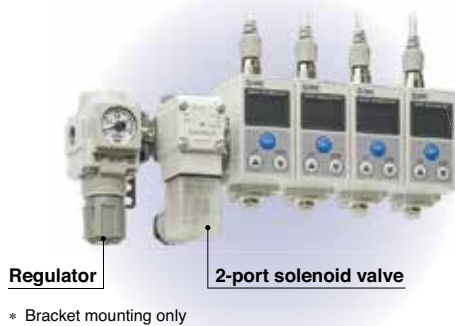

Without control unit



Supply port: Left side



Supply port: Right side



\* The electrical entry of the centralized lead wire for the M12 connector is on the right side.  
When using a right-sided supply port, arrange the centralized lead wire so that it does not interfere with the control unit.

## Application Examples

- Detection of the table and pallet seating

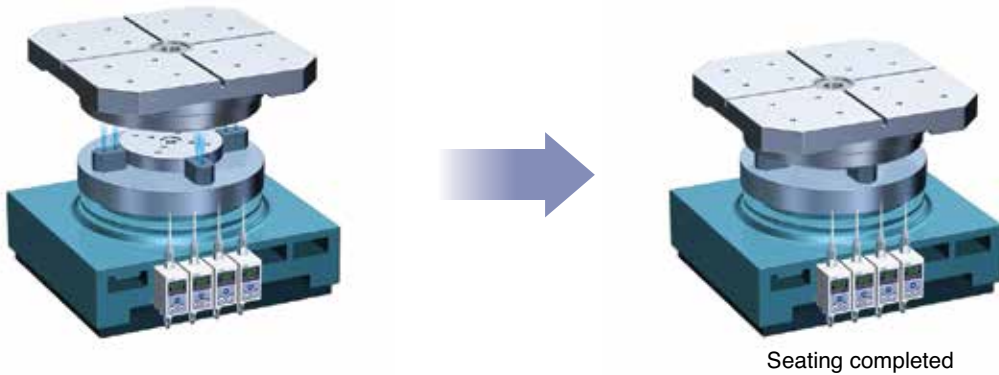

- Workpiece clamp detection

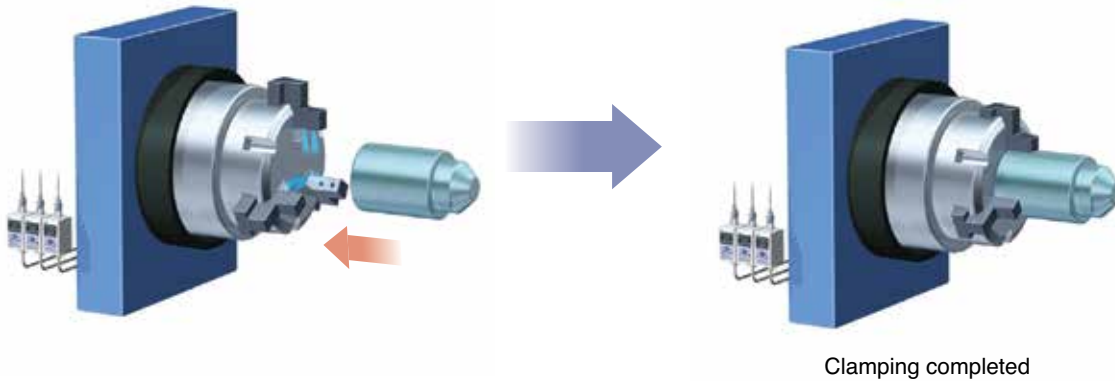

## Main Functions

### ■ Display OFF mode

Display OFF mode can be selected. The display can be turned OFF to reduce power consumption.



### ■ Security code

When the security code is activated, the code needs to be entered before the product can be operated.

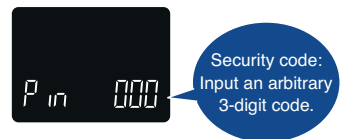

### ■ Display color

The color of the main display can be set to change depending upon the output activity. The display color change makes visual identification of the output ON/OFF easier.

When ON: Green	When OFF: Orange
When ON: Orange	When OFF: Green
Normally: Orange	
Normally: Green	

### ■ Displayed value compensation

The displayed value can be corrected within  $\pm 20\%$  R.D. of the displayed value at the time of shipment.

### ■ Forced output

The output can be fixed to an ON/OFF state when starting the system or during maintenance. This enables the confirmation of the wiring and prevents system errors due to unexpected output.

### ■ Unit selection function

the pressure unit displayed on the sub screen can be changed.

Display unit	kPa	bar	psi
Minimum setting resolution	0.1	0.001	0.02

### ■ Zero-clear of pressure value

The pressure value displayed on the sub screen can be cleared to zero.

## Series Variations

		ISA3-L	ISA3
Number of display digits	Main	4	3
	Sub	9	6
Output specifications		IO-Link communication/ OUT1 + OUT2	1 output      2 outputs
OUT1	OUT1	● SIO mode	●      ●
	IO-Link communication	●	—      —
	OUT1 Window comparator mode	●	—      —
	OUT1 Normal/Reversed output setting	●	—      —
OUT2	OUT2	●	—      ●
	OUT2 Window comparator mode	●	—      ● (Cannot be selected when the output target is distance)
	OUT2 Normal/Reversed output setting	●	—      ● (Cannot be selected when the output target is distance)
	OUT2 Error output, Output OFF setting	●	—      —
	OUT2 Delay time setting	● ON/OFF dual (variable type)	—      ● (Selectable)
Setting mode	3-step setting mode	● * Depends on the sub screen	●
	Simple setting mode	●	—
	Function selection mode	●	●
Function	Display fine adjustment	●	●
	Dual display	●	—
	Line name display	● Dual display is available.	—
	Zero cut-off range can be changed.	●	—
	Display OFF function	●	●
	Security code	●	●
	Setting of all functions	●	●
	Pressure zero-clear	●	●
	Pressure span adjustment	●	—
	Test output	●	●
	Initialization	●	●

Unit conversion table is located inside back cover.



# 3-Screen Display Digital Gap Checker Without Control Unit

## ISA3-L Series

RoHS

### How to Order

ISA3-**G****C****L**-**M****2**

#### Rated distance range

<b>F</b>	0.01 to 0.03 mm
<b>G</b>	0.02 to 0.15 mm
<b>H</b>	0.05 to 0.30 mm

#### Piping specification

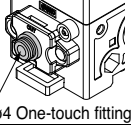
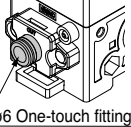
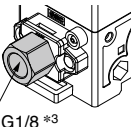
	Supply side	Detection side
<b>C</b>	Rc1/8	 ø4 One-touch fitting *1
		 ø6 One-touch fitting *2
<b>F</b>	G1/8 *3	 G1/8 *3

- \*1 When F is selected for the rated distance range
- \*2 When G or H is selected for the rated distance range
- \*3 Conforming to ISO 1179-1

#### Output specification

**L** IO-Link: Switch output 1 + Switch output 2 (Switch output: NPN or PNP switching type)

OUT1: Gap size detection  
OUT2: Gap size, outlet pressure, supply pressure detection (Select from the above.)

#### Unit specification of pressure value

<b>Nil</b>	With unit selection function *9
<b>M</b>	Fixed SI unit *10

- \*9 Under the New Measurement Act, digital gap checkers with the unit selection function are no longer allowed for use in Japan.
- \*10 Unit: kPa

#### Stations

<b>1</b>	1 station
<b>2</b>	2 stations
<b>3</b>	3 stations
<b>4</b>	4 stations
<b>5</b>	5 stations
<b>6</b>	6 stations

#### Option 1 (Cable)

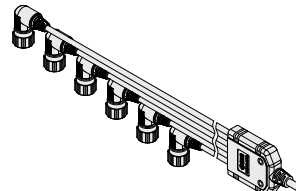
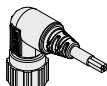
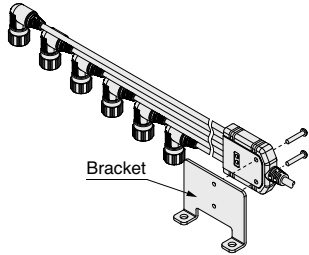
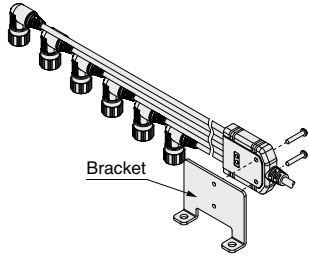
<b>Nil</b>	Straight *5 *6 	<b>S</b>	Centralized lead wire (Lead wire only) *4 *5 
<b>L</b>	Right angle *5 *6 		Centralized lead wire (With bracket) *4 *5 
<b>N</b>	None	<b>T</b>	Centralized lead wire (With bracket) *4 *5 
<ul style="list-style-type: none"> <li>*4 Cannot be selected for 1 station. One set is provided per manifold. A centralized lead wire is provided with M12 connectors for the number of stations. Refer to page 25 for details.</li> <li>*5 At the factory, the options are not attached to the product, but packed together with it for shipment.</li> <li>*6 Cables are provided for the number of stations.</li> </ul>			Bracket

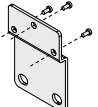

#### Option 2 (Bracket)

<b>Nil</b>	None (DIN rail mounting) *7
<b>B</b>	With bracket *5 *8 

- \*7 Order DIN rail separately. (Refer to page 21.)
- \*8 About the number of brackets, 1 station: 1 piece is packed, 2 stations or more: 2 pieces are packed.

#### Bracket mounting position

**2 stations**  
(Mount to 1st and 2nd stations)



**n stations**  
(Mount to 1st and nth stations)



mm ÷ 25.4 = Inches

# 3-Screen Display Digital Gap Checker With Control Unit ISA3-L Series



## How to Order

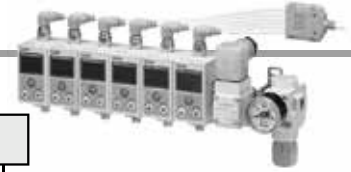

ISA3-GCL-M2 B-L1

### Rated distance range

F	0.01 to 0.03 mm
G	0.02 to 0.15 mm
H	0.05 to 0.30 mm

### Piping specification

	Supply side	Detection side
C	Rc1/8	$\phi 4$ One-touch fitting *1
		$\phi 6$ One-touch fitting *2
F	G1/8 *3	G1/8 *3

\*1 When F is selected for the rated distance range

\*2 When G or H is selected for the rated distance range

\*3 Conforming to ISO 1179-1

### Output specification

**L** IO-Link: Switch output 1 + Switch output 2 (Switch output: NPN or PNP switching type)

OUT1: Gap size detection  
OUT2: Gap size, outlet pressure, supply pressure detection (Select from the above.)

### Unit specification of pressure value

Nil	With unit selection function *12
M	Fixed SI unit *13

\*12 Under the New Measurement Act, digital gap checkers with the unit selection function are no longer allowed for use in Japan.

\*13 Unit: kPa

### Stations

1	1 station
2	2 stations
3	3 stations
4	4 stations
5	5 stations
6	6 stations

### Option 1 (Cable)

Nil	Straight *5 *6 	S	Centralized lead wire (Lead wire only) *4 *5 
L	Right angle *5 *6 		
N	None	T	Centralized lead wire (With bracket) *4 *5 

\*4 Cannot be selected for 1 station. One set is provided per manifold. A centralized lead wire is provided with M12 connectors for the number of stations. Refer to page 25 for details.

\*5 At the factory, the options are not attached to the product, but packed together with it for shipment.

\*6 Cables are provided for the number of stations.

### 2-port solenoid valve rated voltage

Nil	24 VDC
1 *11	100 VAC
2 *11	110 VAC

\*11 Produced upon receipt of order

### Regulator (Refer to page 22.)

N *10	Without regulator		
0 *10	Without pressure gauge		
1	With regulator	Round type pressure gauge	0.4 MPa
		Square type pressure gauge	
		Round type pressure gauge	0.2 MPa
		Square type pressure gauge	
5 *10	Round type pressure gauge	0.4 MPa	MPa-psi double notation
6 *10	Square type pressure gauge		
7 *10	Round type pressure gauge	0.2 MPa	MPa-psi double notation
8 *10	Square type pressure gauge		

\*10 Produced upon receipt of order

### Control unit (Regulator, 2-port valve)

L	Control unit (Supply port: Left side) 
R	Control unit (Supply port: Right side) 

### Control unit piping specification \*8

Gap checker piping specification	Supply port piping specification
C	Rc1/4
F	G1/4 *9

\*8 When the control unit is mounted, the piping specifications of the supply port will be changed due to piping specification of the gap checker.

\*9 Conforming to ISO 16030

### Option 2 (Bracket)

B	With bracket *7 
---	---------------------

\*7 The bracket for control unit is shipped mounted on the product.

# ISA3-L Series

For gap checker precautions and specific product precautions, refer to the "Operation Manual" on the SMC website.

## Specifications

Model		ISA3-FL	ISA3-GL	ISA3-HL
<b>Applicable fluid</b>		Dry air (Filtered through a 5 µm filter)		
<b>OUT1 OUT2 *6</b>	<b>Rated distance range</b>	0.01 to 0.03 mm	0.02 to 0.15 mm	0.05 to 0.30 mm
	<b>Displayable/Settable range (Distance reference) *1</b>	0 to 60 *2	0 to 300 *2 *3	0 to 500 *2 *4
	<b>Minimum display resolution (Distance reference) *1</b>	1		
	<b>Rated pressure range</b>	100.0 to 200.0 kPa		
	<b>Displayable range (Pressure value) *5</b>	-20.0 to 220.0 kPa		
	<b>Repeatability</b>	0.005 mm or less	0.010 mm or less	0.020 mm or less
	<b>Temperature characteristics (Reference: 25°C)</b>	0.010 mm or less	0.015 mm or less	0.030 mm or less
<b>Hysteresis</b>	0 to variable (Default: 3)	0 to variable (Default: 20)		
<b>OUT2 *7</b>	<b>Rated pressure range</b>	0.0 to 200.0 kPa		
	<b>Set pressure range</b>	-20.0 to 220.0 kPa		
	<b>Minimum display/setting resolution</b>	0.1 kPa		
	<b>Repeatability</b>	±0.5% F.S. ±1 digit		
	<b>Temperature characteristics (Reference: 25°C)</b>	±2% F.S.		
<b>Hysteresis</b>	0 to variable *8			
<b>Withstand pressure</b>		600 kPa		
<b>Detection nozzle</b>		ø1.5 *9		
<b>Consumption flow rate</b>		5 L/min or less	12 L/min or less	22 L/min or less
<b>Electrical</b>	<b>Power supply voltage</b>	When used as a switch output device: 24 VDC ±10% with 10% voltage ripple or less When used as an IO-Link device: 18 to 30 VDC, including ripple (p-p) 10%		
	<b>Current consumption</b>	25 mA or less		
	<b>Protection</b>	Power supply polarity protection		
<b>Switch output</b>		Select from NPN or PNP open collector output.		
	<b>Maximum load current</b>	10 mA		
	<b>Maximum applied voltage</b>	30.0 V		
	<b>Residual voltage</b>	1 V or less (at 10 mA)		
	<b>Short-circuit protection</b>	Provided		
<b>Display</b>		2-screen display (3 types of display are available: Sub screen: 4-digit x 2) Main screen: 4-digit 7-segment, 2-color (Orange/Green) Sub screen: 9-digit (Upper 9-digit, 4-digit, 3-digit 11-segment, 7-segment for other) IP67 equivalent *10		
<b>Environmental resistance</b>	<b>Enclosure</b>	IP67 equivalent *10		
	<b>Operating temperature range</b>	Operating: 0 to 50°C, Stored: -20 to 70°C (No condensation or freezing)		
	<b>Operating humidity range</b>	Operating/stored: 35 to 85% RH (No condensation)		
	<b>Withstand voltage</b>	1000 VAC or more (in 50/60 Hz) for 1 minute between terminals and housing		
<b>Insulation resistance</b>		2 MΩ or more (500 VDC measured via megohmmeter) between terminals and housing		
<b>Piping</b>	<b>For C type</b>	<b>Supply port</b>	Rc1/8	
		<b>Detection port</b>	ø4 One-touch fitting	ø6 One-touch fitting
	<b>For F type</b>	<b>Supply port</b>	G1/8 (Conforming to ISO 1179-1)	
		<b>Detection port</b>	G1/8 (Conforming to ISO 1179-1)	
<b>Cable</b>	<b>Lead wire with connector</b>	M12 lead wire with 4 pin connector, 4 cores, ø4, 5 m Conductor O.D.: 0.72 mm, Insulator O.D.: 1.14 mm		
	<b>Centralized lead wire</b>	M12 lead wire with 4 pin connector part, 4 cores, ø4, Insulator O.D.: 1.14 mm Centralized lead wire part, 2 to 3 stations: 8 cores, ø6, 5 m, 4 to 6 stations: 14 cores, ø6, 5 m Conductor O.D.: 0.50 mm, Insulator O.D.: 1.00 mm (2 to 6 stations common)		
<b>Weight</b>		113 g (Cable not included, One-touch fitting)		
<b>Standards</b>		CE marking (EMC Directive, RoHS Directive)		
<b>Communication (IO-Link mode)</b>	<b>IO-Link type</b>	Device		
	<b>IO-Link version</b>	V1.1		
	<b>Communication speed</b>	COM2 (38.4 kbps)		
	<b>Configuration file</b>	IODD file *11		
	<b>Minimum cycle time</b>	4.2 ms		
	<b>Process data length</b>	Input data: 8 bytes, Output data: 0 bytes		
	<b>On request data communication</b>	Yes		
	<b>Data storage function</b>	Yes		
	<b>Event function</b>	Yes		
<b>Vendor ID</b>	131 (0 x 0083)			

\*1 For details, refer to the Relationship Between Displayed Value and Distance on page 18.

\*2 If hysteresis is set to 3 (Default setting), the "Displayable/Settable range" of the F type is limited to 57. If hysteresis is set to 20 (Default setting), the G type is limited to 280 and the H type is limited to 480. (Reversed output: Factory default value)

\*3 Due to the zero-cut function, the values of 8 and under are displayed as 0 at factory default setting.

\*4 Due to the zero-cut function, the values of 29 and under are displayed as 0 at factory default setting.

\*5 The pressure value will be the indicated on the sub screen.

\*6 Refers to when OUT2 is set to detect the distance

\*7 Refers to when OUT2 is set to detect the pressure

\*8 If the applied pressure fluctuates around the set value, the hysteresis must be set to a value more than the fluctuating width, otherwise chattering will occur.

\*9 For details on the detection nozzle, refer to the figures on page 18.

\*10 Only applies to the digital gap checker body excluding the control unit.

\*11 The configuration file can be downloaded from the SMC website.

\* Products with tiny scratches, marks, or display color or brightness variations which do not affect the performance of the product are verified as conforming products.

### Rated Distance Range and Displayable/Settable Range



The displayed value is a reference value obtained by converting the distance between the workpiece and the detection surface into a digital numerical value. It is not displayed in units. For details, refer to the Relationship Between Displayed Value and Distance on page 18.

Rated distance range: Distance range within which the product meets the specifications

Displayable/Settable range: Range within which it is possible to display or set values, (Not guaranteed to meet the specifications)

Model	Distance				
	0 mm	0.02 mm	0.05 mm	0.15 mm	0.30 mm
ISA3-F type	[Bar chart showing ranges for ISA3-F type]				
ISA3-G type	[Bar chart showing ranges for ISA3-G type]				
ISA3-H type	[Bar chart showing ranges for ISA3-H type]				

■ Rated distance range    ▨ Displayable/Settable range    ⋯⋯⋯ When zero cut-off is minimum





### Supply Pressure Dependence Characteristics

The distance for the product to turn ON varies depending on the supply pressure.

The graphs below show the variation of the distance for the product to turn ON, for 3 types of gap, by changing the supply pressure ( $\pm 50$  kPa) when the product is set to turn ON at 150 kPa supply pressure.

<b>Test conditions</b>	<b>Detection nozzle:</b> $\phi 1.5$ <b>Piping:</b> F type $\phi 4 \times \phi 2.5$ tube/G, H type $\phi 6 \times \phi 4$ tube <b>Reference pressure:</b> 150 kPa
------------------------	---

\* Use within the rated pressure range (100 kPa to 200 kPa).  
 It will be impossible to measure the gap when the operating pressure is less than 80 kPa or over 220 kPa. And the output will be OFF.  
 (Refer to the Relationship Between Supply Pressure and Display on page 26.)

#### ISA3-FL

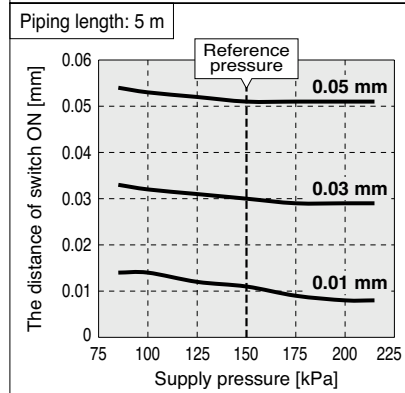
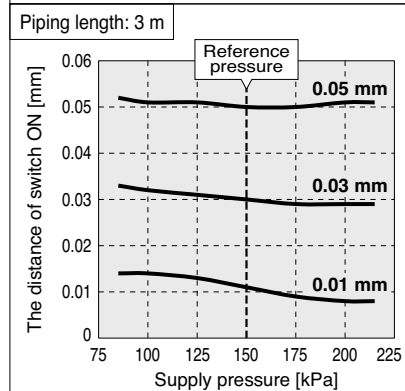
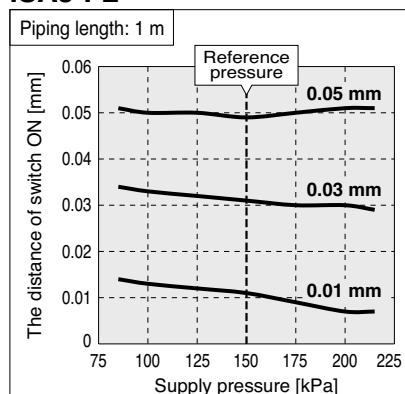

#### ISA3-GL

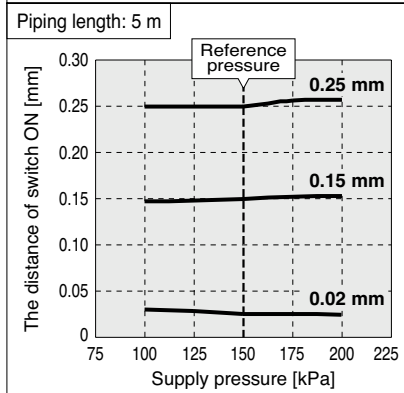
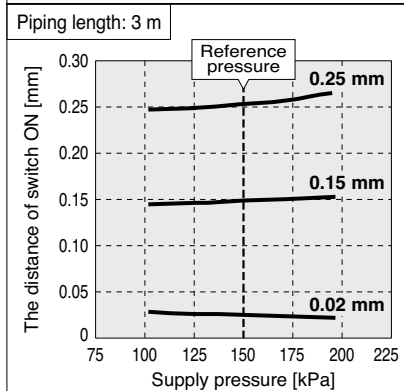
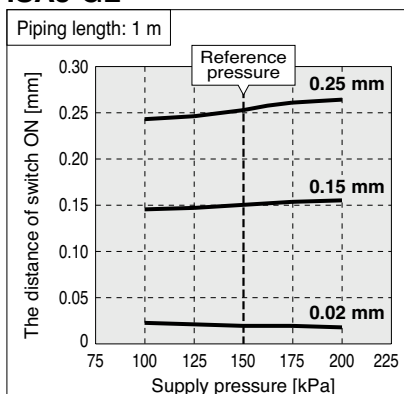

#### ISA3-HL

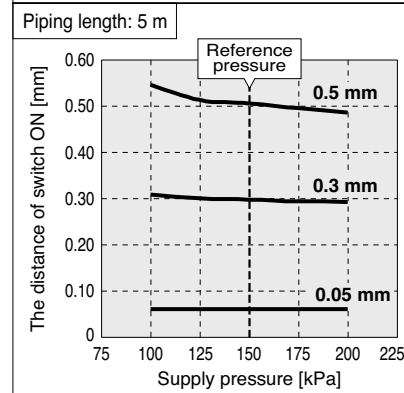
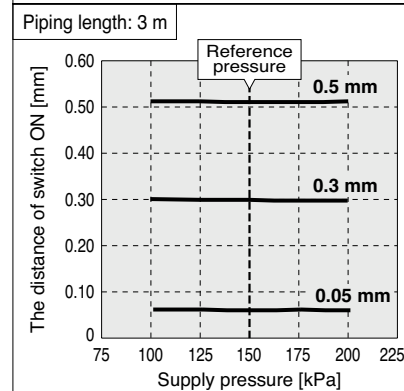
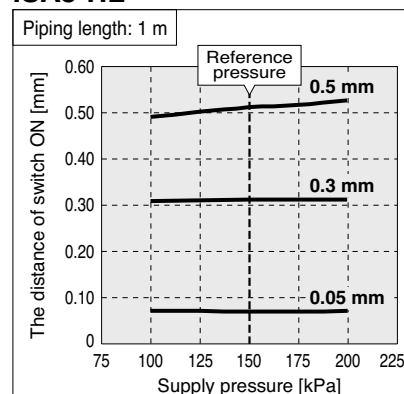

# ISA3-L Series

## Response Time

Response time is the elapsed time between the pressure supply and the turning ON of the switch output.

The response time varies depending on the piping length from the OUT port to the detection nozzle, and the seating condition of the workpiece. The graphs below show the response time when the workpiece is approached at 90% distance and 0% distance (close contact). (\* The switch point is 100% distance.)

(Example: When the switch point is set to 0.1 mm, the response time when the workpiece is at 0.09 mm and 0 mm are measured.)

<b>Test conditions</b>	<b>Detection nozzle:</b> $\phi 1.5$ <b>Piping:</b> F type $\phi 4 \times \phi 2.5$ tube/G, H type $\phi 6 \times \phi 4$ tube <b>Supply pressure:</b> 200 kPa
------------------------	--

— Response time when the workpiece is set at 90% distance  
- - - Response time for close contact of workpiece

### ISA3-FL

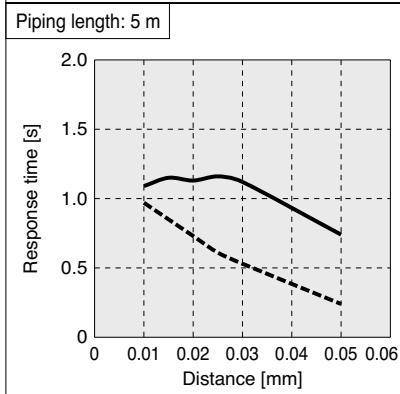
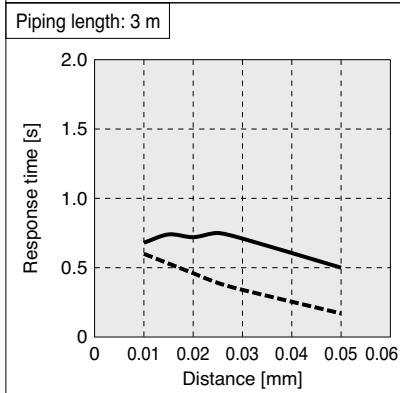
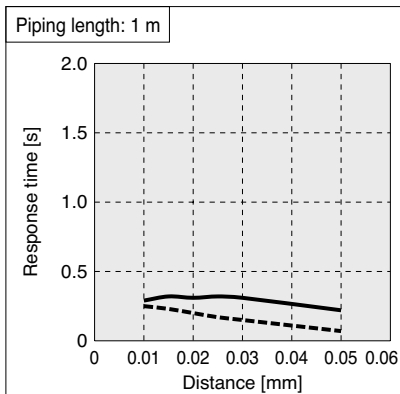

### ISA3-GL

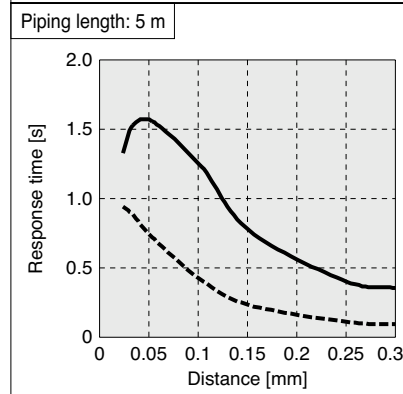
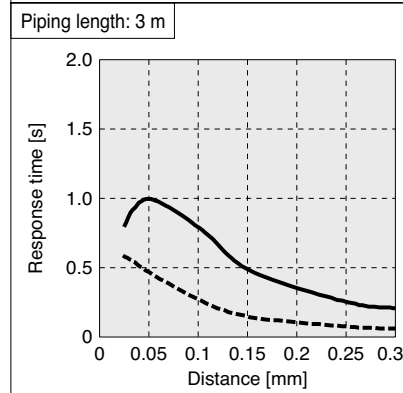
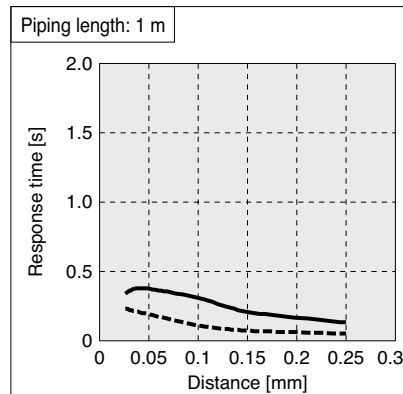

### ISA3-HL

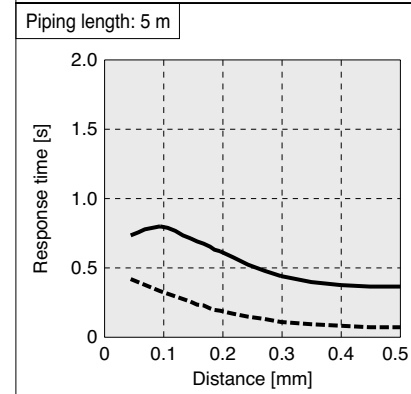
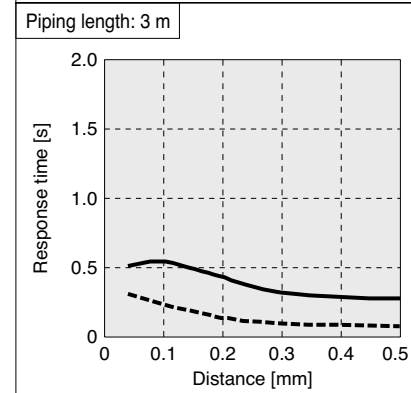
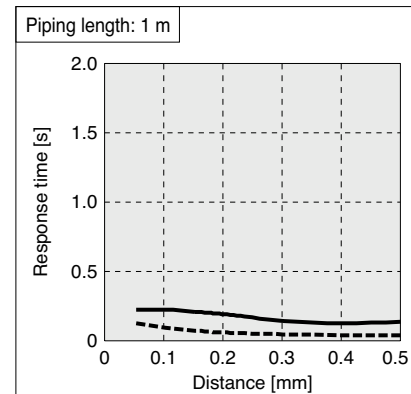

### Relationship Between Displayed Value and Distance

The graphs below show the relationship between the displayed value and distance.

- The data shown below are for reference. They change depending on the individual product differences and machining dimensions of the nozzle.
- The zero-cut function forcibly displays 0 when the value is less than the set value. Although the zero cut-off range can be set to 0, it may not be 0 even in close contact, due to the characteristics of the product.

Test conditions	Detection nozzle: $\phi 1.5$
	Detection nozzle piping: F type $\phi 4 \times \phi 2.5$ tube 1 m, 3 m, 5 m / G, H type $\phi 6 \times \phi 4$ tube 1 m, 3 m, 5 m
	Supply pressure: 200 kPa

#### ISA3-FL

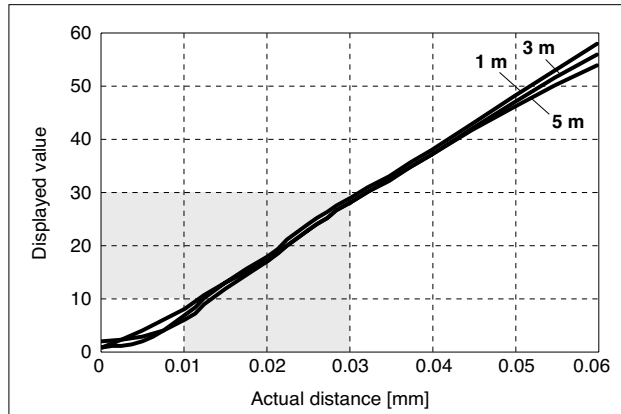

#### ISA3-GL

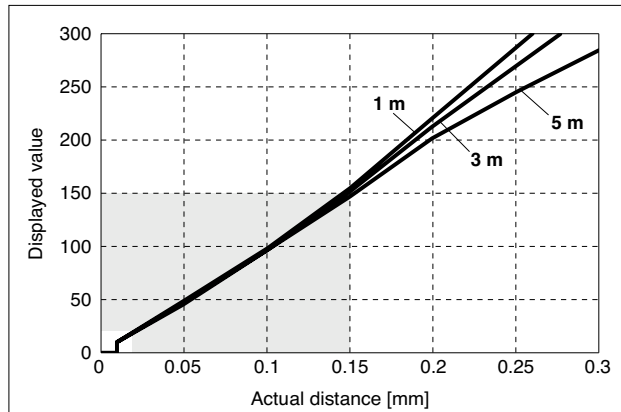

\* Default setting: Values of 8 and under are displayed as "0."

#### ISA3-HL

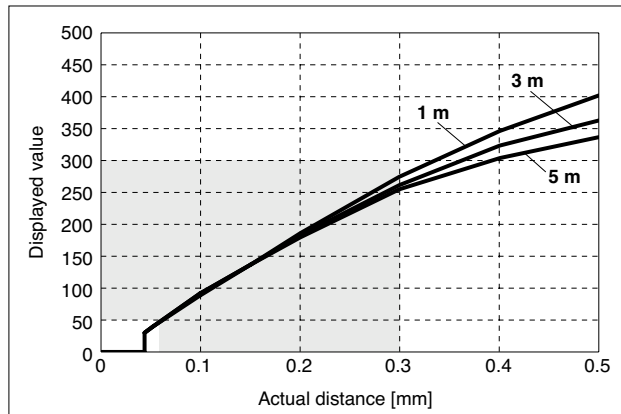

\* Default setting: Values of 29 and under are displayed as "0."

Unit conversion table is located inside back cover.

### Detection Nozzle Shape

The nozzle shape must be similar to Fig. 1.

Do not chamfer the nozzle as shown in Fig. 2, as the characteristics will be affected.

Fig. 1: Recommended nozzle shape

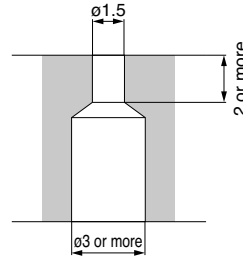
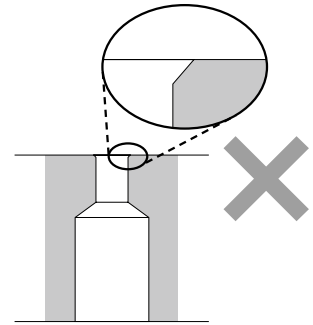

Fig. 2: Unsuitable nozzle shape



### Internal Circuits and Wiring Examples

#### When used as a switch output device

\* The numbers in the circuit diagrams show the connector pin layout.

##### Setting of NPN open collector 2 outputs

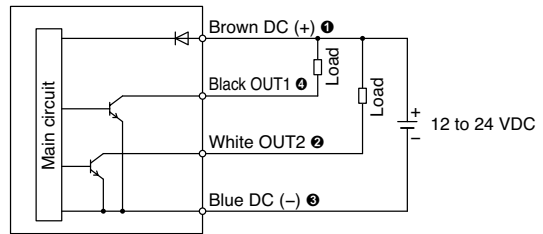

##### Setting of PNP open collector 2 outputs

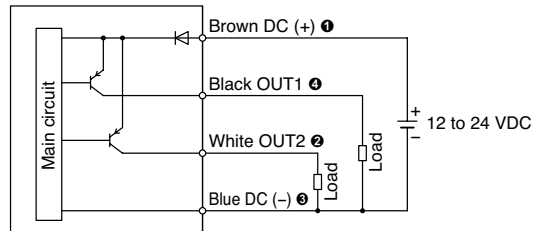

#### When used as an IO-Link device

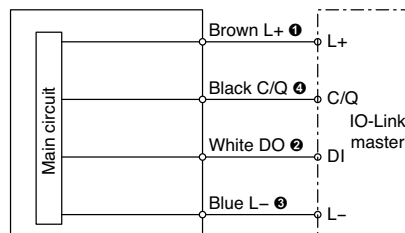

\* Refer to the **Web Catalog** for wiring details of the VX2 series (2-port solenoid valve).

# ISA3-L Series

## Construction Diagram

### Without control unit

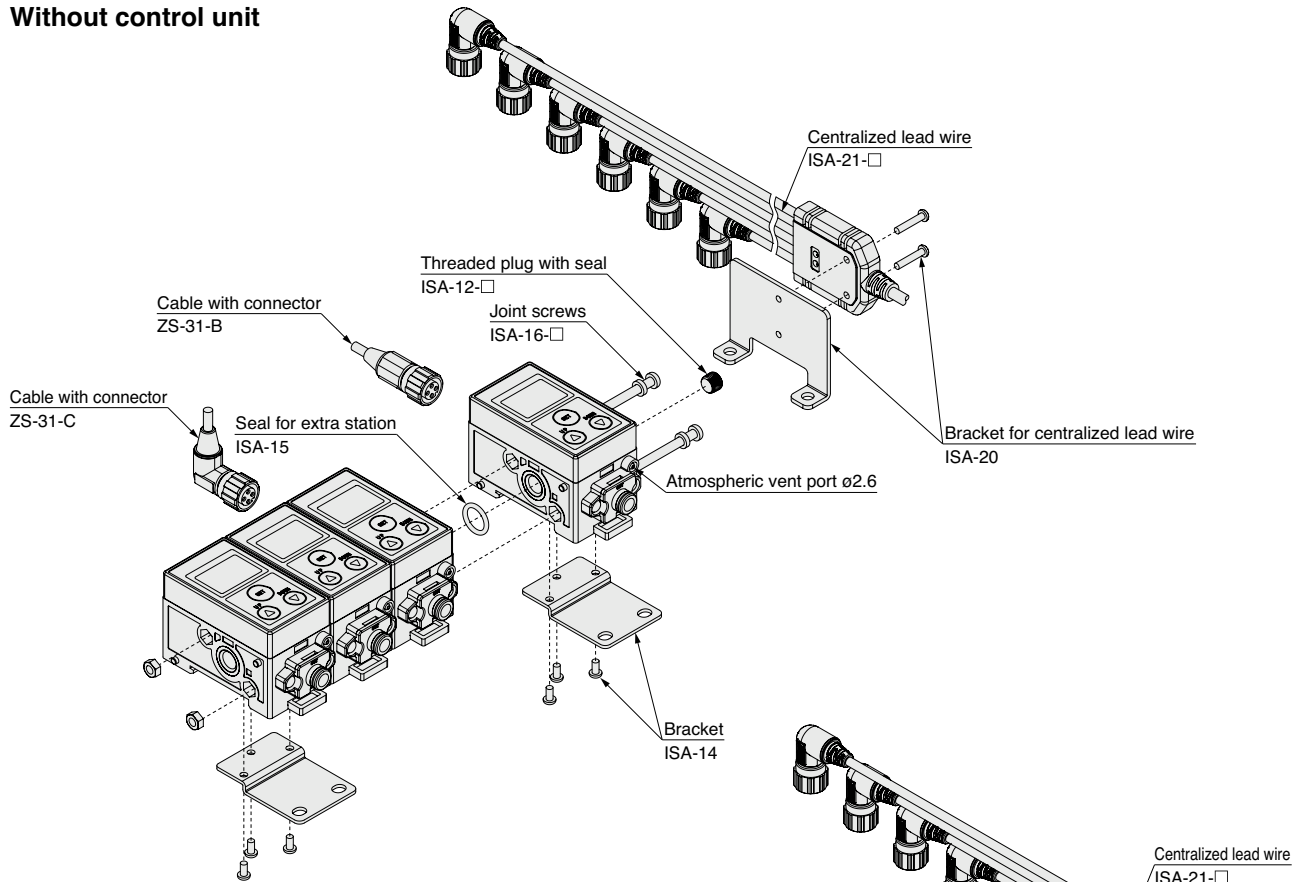

### With control unit Supply port: Left side

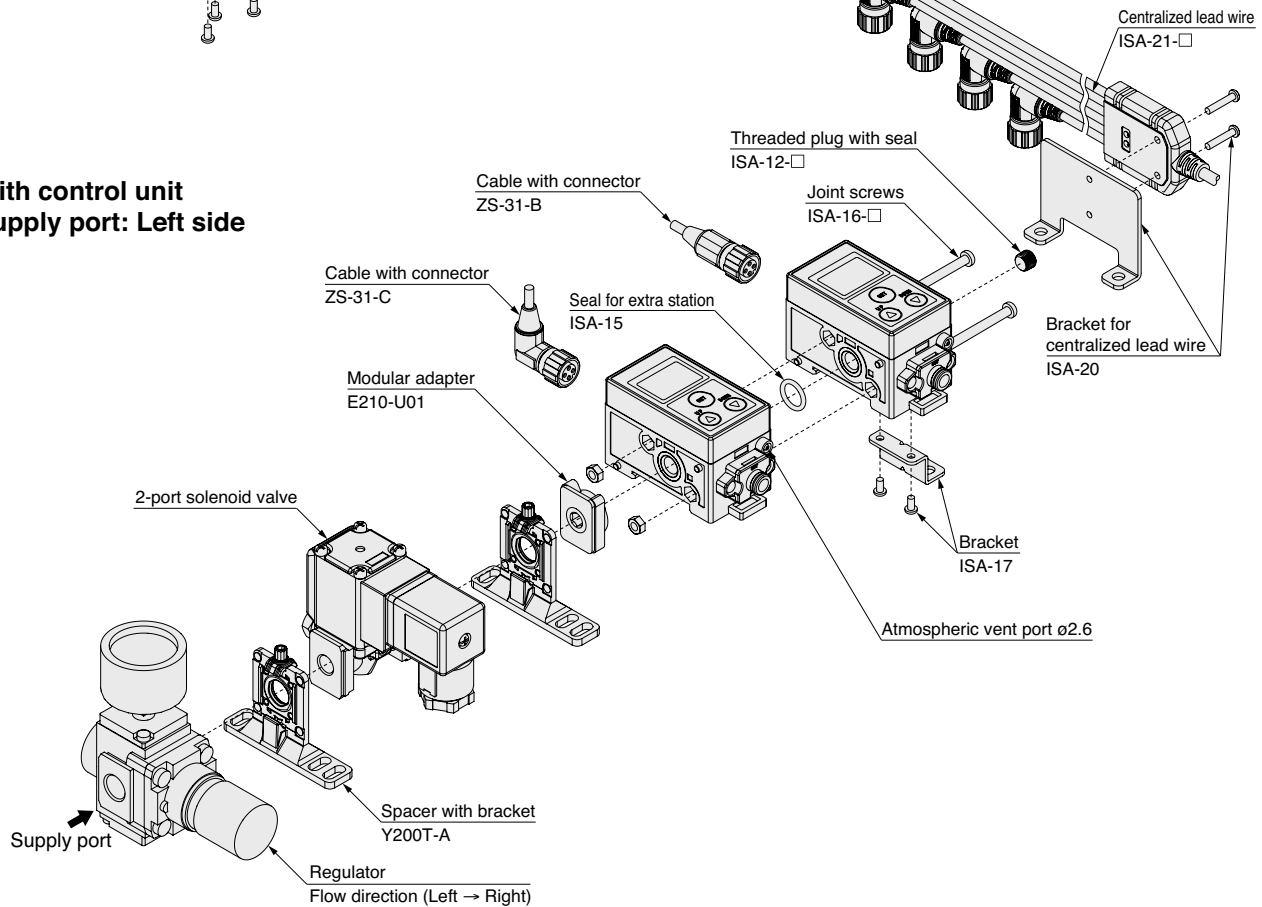



**Construction Diagram**

With control unit  
Supply port: Right side

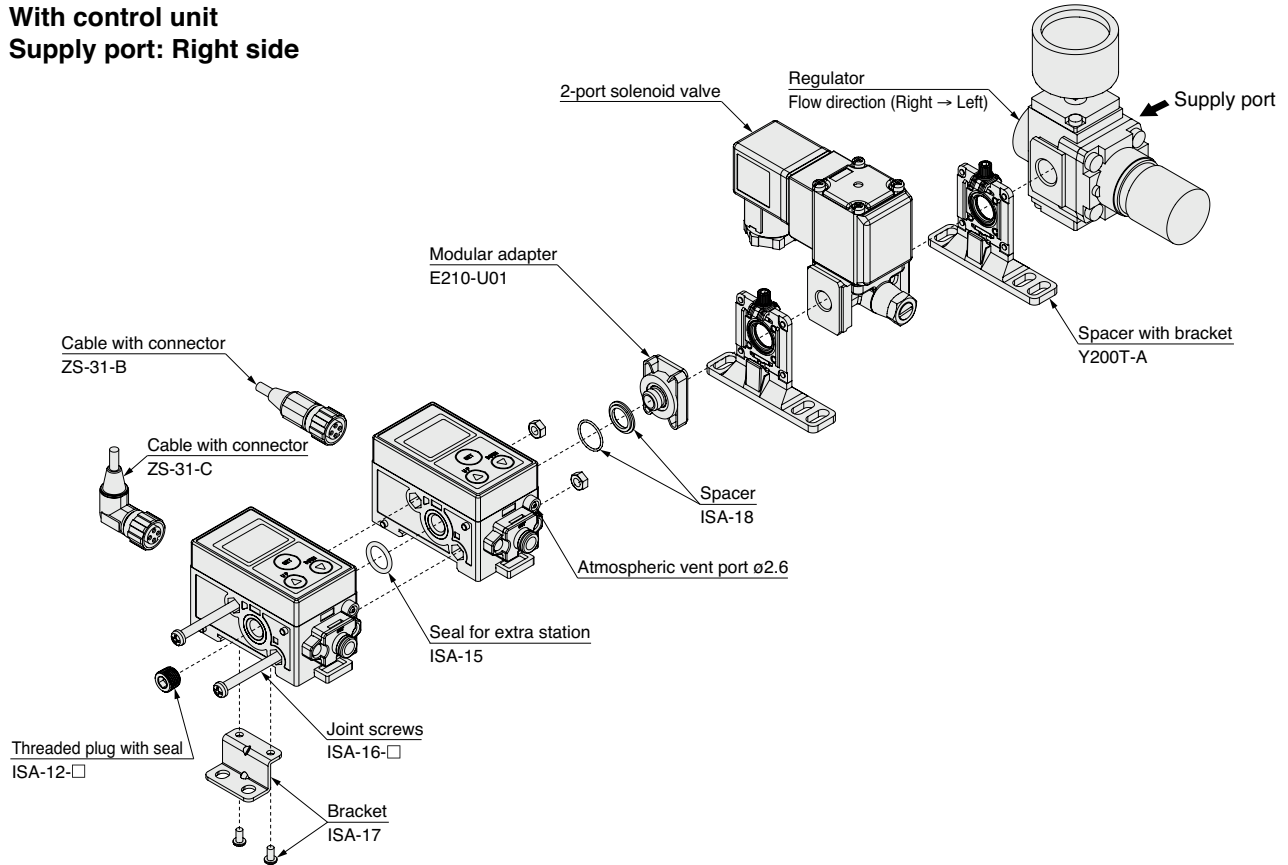

If there is a possibility that the atmospheric vent port of the gap checker will be exposed to water or dust, insert a tube into the atmospheric vent port and route the other end of the tube to a safe place away from water or dust.

\* For tubing, please use the SMC TU0425 (polyurethane, O.D.  $\phi 4$ , I.D.  $\phi 2.5$ ) for the gap checker.

**⚠ Caution**

**SMC products are not intended for use as instruments for legal metrology.**

Measurement instruments that SMC manufactures or sells have not been qualified by type approval tests relevant to the metrology (measurement) laws of each country. Therefore, SMC products cannot be used for business or certification ordained by the metrology (measurement) laws of each country.

# ISA3-L Series

## Parts List

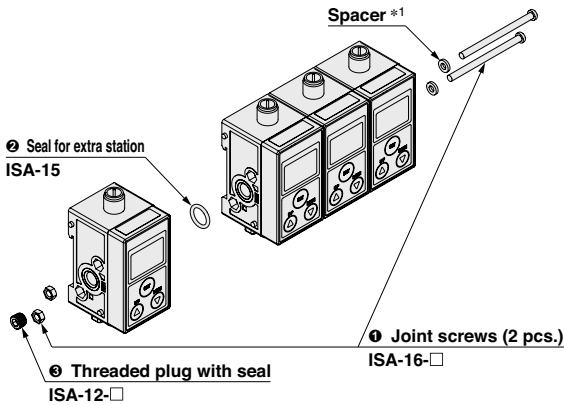

\*1 Spacers are included for 4 and 6 stations.

① Joint screws  
2 screws,  
2 spacers, 2 nuts

Stations	Part no.
2	ISA-16-2
3	ISA-16-3
4 *1	ISA-16-4
5	ISA-16-5
6 *1	ISA-16-6

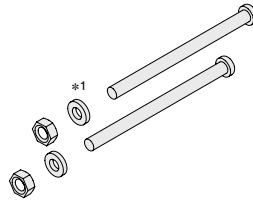

② Seal for extra station  
ISA-15 1 pc.



③ Threaded plug with seal  
ISA-12-□ 1 pc.

Piping	Part no.
Rc1/8	ISA-12-A
G1/8	ISA-12-C



### ■ Bracket ISA-14

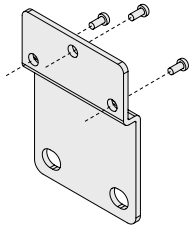

With 3 tapping screws (3 x 8)

### ■ DIN rail ISA-5-1

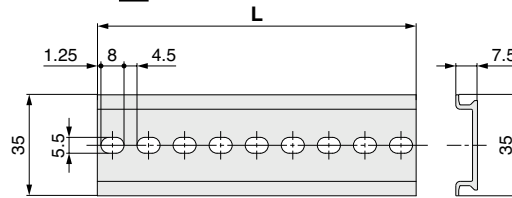

Stations	Part no.	L
1	ISA-5-1	73.0
2	ISA-5-2	135.5
3	ISA-5-3	173.0
4	ISA-5-4	210.5
5	ISA-5-5	248.0
6	ISA-5-6	285.5

### ■ Lead wire with connector ZS-31-B      ZS-31-C

Straight 5 m

Right angle 5 m

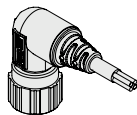

### ■ Centralized lead wire ISA-21-2

Stations	Part no.	L
2	ISA-21-2	139
3	ISA-21-3	177
4	ISA-21-4	215
5	ISA-21-5	253
6	ISA-21-6	291

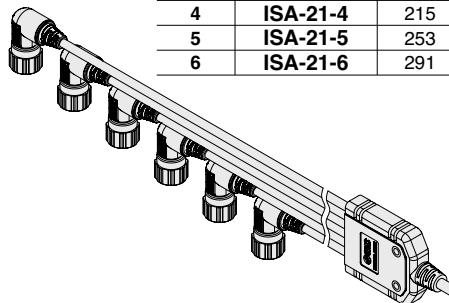

### ■ Bracket for centralized lead wire ISA-20

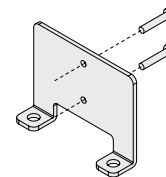

\* With 2 mounting screws (M3 x 16L)

### Parts List (Control Unit)

#### ■ Regulator

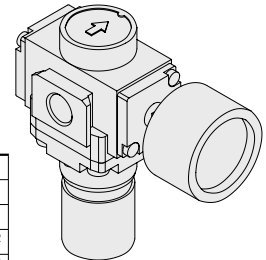
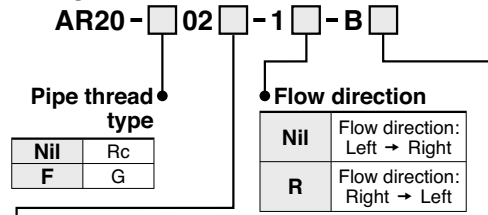

#### ● Option (Pressure gauge shape)

Option	Description	Max. display pressure of the pressure gauge
Nil	Without pressure gauge	Nil
E	With square embedded type pressure gauge (With limit indicator)	Nil
		-X2105
		-X2176
G*1	With round type pressure gauge (With limit indicator, MPa single notation)	Nil
		-X2105
P*1	With round type pressure gauge (With limit indicator, MPa-psi double notation*2)	Nil
		-X2105

\*1 The pressure gauge port is 1/8. The pressure gauge is included in the package, but not assembled.

\*2 This product is for overseas use only according to the New Measurement Act. (The SI unit type is provided for use in Japan.)

For details, refer to the [Web Catalog](#).

#### ■ 2-port solenoid valve

VX210  Z  Z2A  X276

● Body material/Port size/Orifice diameter

Symbol	Body material	Port size	Orifice diameter
Z	Aluminum	No thread machining (1/8)	ø4
B*1		Rc1/4	
D*1		G1/4	

\*1 Produced upon receipt of order

● Specification

Symbol	Specification
X276	With restrictor

● Voltage/Electrical entry

Symbol	Voltage	Electrical entry
Z2A	24 VDC	DIN terminal with light (With surge voltage suppressor)
Z2B*2	100 VAC	
Z2C*2	110 VAC	

\*2 Produced upon receipt of order  
When 100 VAC and 110 VAC are selected, the product without thread machining (symbol: Z) cannot be selected.

Restrictor needle

For specifications other than X276, refer to the [Web Catalog](#).

#### ■ Bracket (when control unit fitted) ISA-17

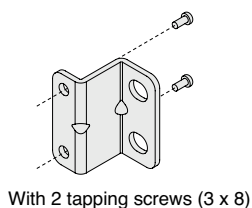

#### ■ Spacer with bracket Y200T-A

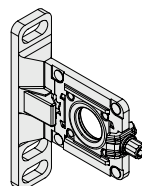

#### ■ Modular adapter E210-U01

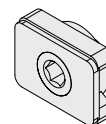

#### ■ Spacer ISA-18

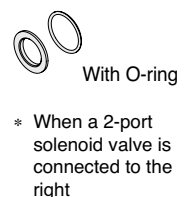

# ISA3-L Series

## Dimensions

### ISA3-□□L-□□□□B (Bracket mounting)

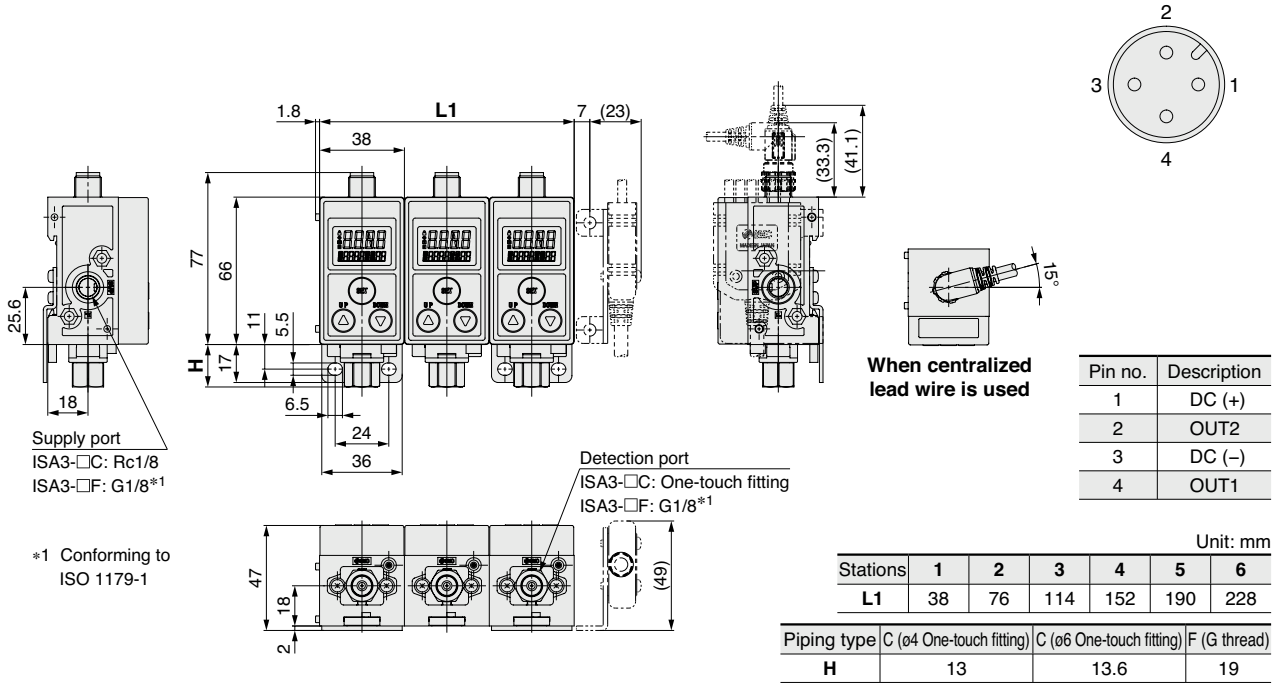

### ISA3-□□L-□□□□ (DIN rail mounting)

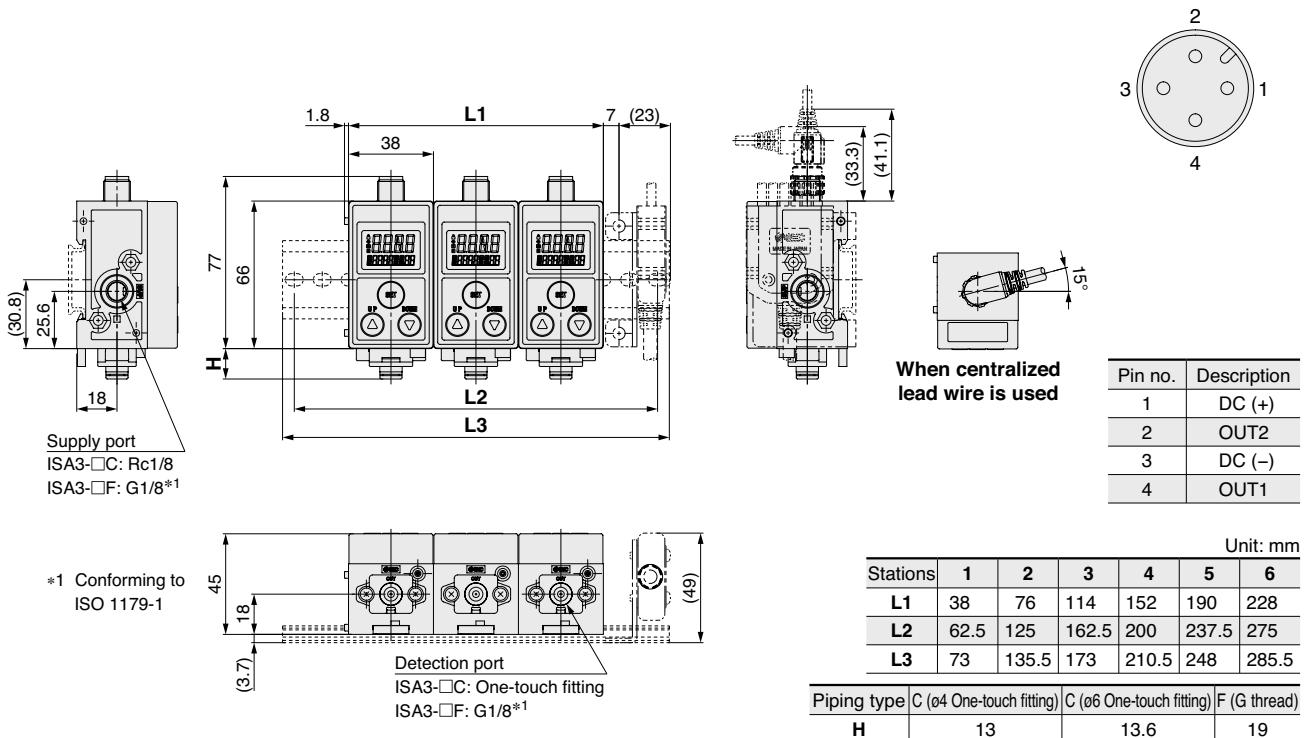



## Dimensions

### ISA3-□□L-□□□B-L □ (With control unit)

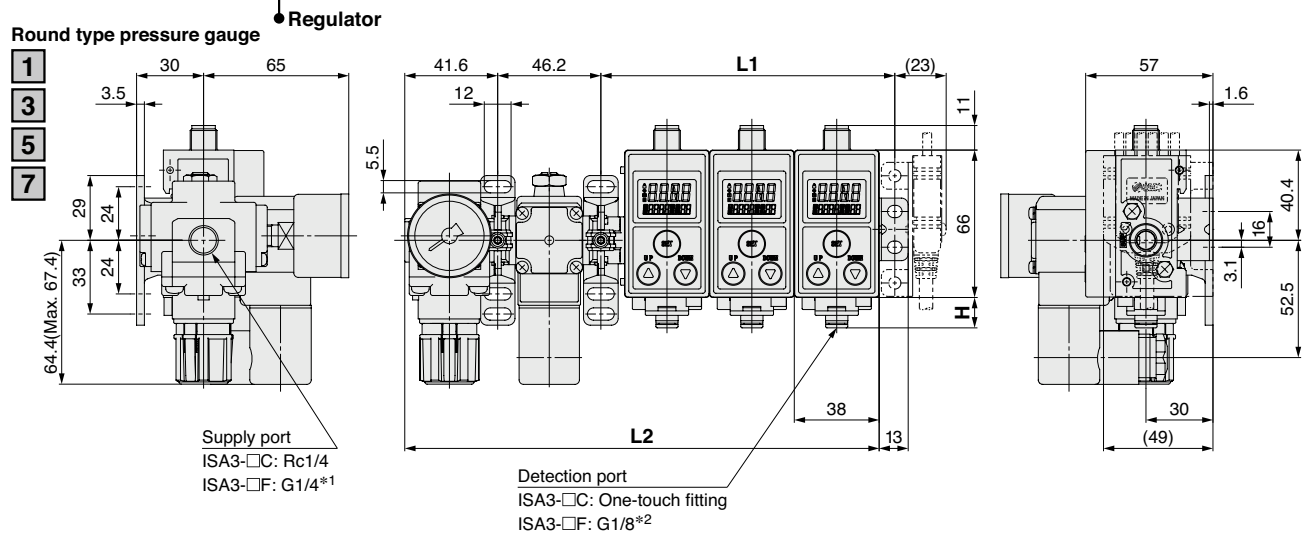

### ISA3-□□L-□□□B-R □

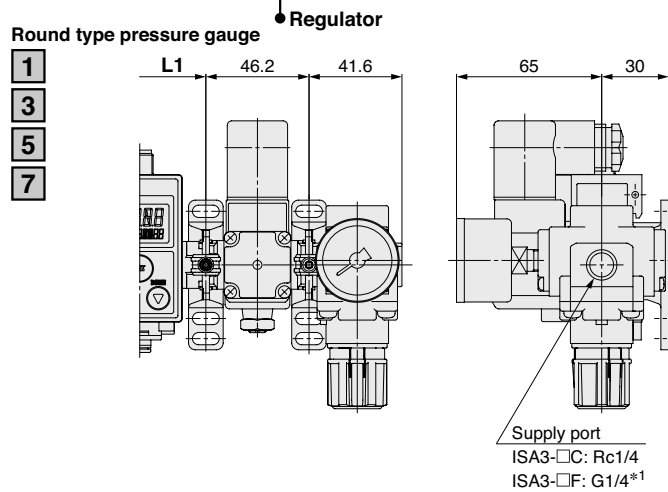

### ISA3-□□L-□□□B-R □

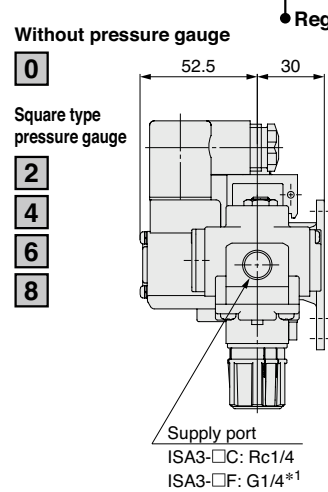

### ISA3-□□L-□□□B-LN □

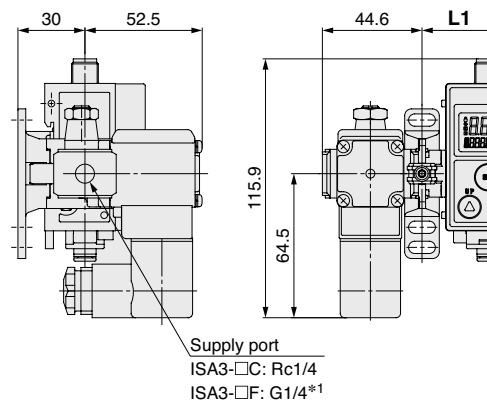

### ISA3-□□L-□□□B-RN □

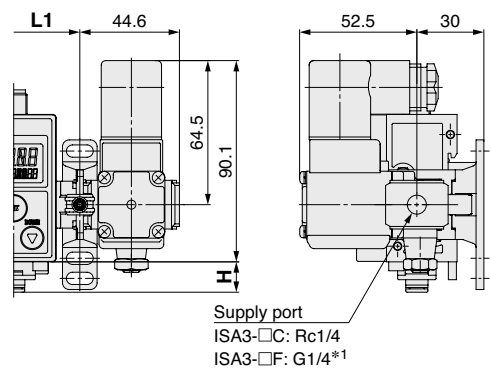

Unit: mm

Stations	1	2	3	4	5	6
L1	55.6	93.6	131.6	169.6	207.6	245.6
L2	136.4	174.4	212.4	250.4	288.4	326.4
H	13		13.6		19	

\*1 Conforming to ISO 16030

\*2 Conforming to ISO 1179-1

\* Bracket mounting only

Unit conversion table is located inside back cover.

# ISA3-L Series

## Dimensions

### ZS-31-B (Cable with connector)

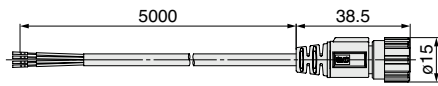

### Connector pin no.



### ZS-31-C (Cable with connector)

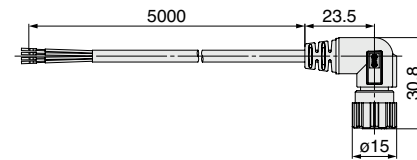

Pin no.	Lead wire color	Description	Pin no.	Lead wire color	Description
1	Brown	DC(+)	3	Blue	DC(-)
2	White	OUT2	4	Black	OUT1

### ISA-21-□ (Centralized lead wire)

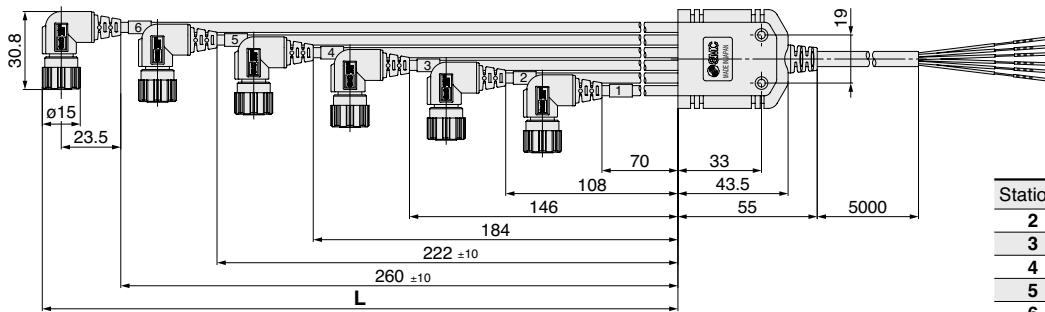

Unit: mm

Stations	Part no.	L
2	ISA-21-2	139
3	ISA-21-3	177
4	ISA-21-4	215
5	ISA-21-5	253
6	ISA-21-6	291

#### For 2 to 3 Stations

M12 connector no.	Pin no.	Description	Output lead wire color
1	1	DC(+)	Brown*1 Orange
	2	OUT2	
	3	DC(-)	Blue*1 Black
	4	OUT1	
2	1	DC(+)	Brown*1 Red
	2	OUT2	
	3	DC(-)	Blue*1 White
	4	OUT1	
3	1	DC(+)	Brown*1 Green
	2	OUT2	
	3	DC(-)	Blue*1 Gray
	4	OUT1	

#### For 4 to 6 Stations

M12 connector no.	Pin no.	Description	Output lead wire color
1	1	DC(+)	Brown*1 Yellow
	2	OUT2	
	3	DC(-)	Blue*1 Black
	4	OUT1	
2	1	DC(+)	Brown*1 Purple
	2	OUT2	
	3	DC(-)	Blue*1 White
	4	OUT1	
3	1	DC(+)	Brown*1 Gray/Black
	2	OUT2	
	3	DC(-)	Blue*1 Gray
	4	OUT1	

M12 connector no.	Pin no.	Description	Output lead wire color
4	1	DC(+)	Brown*1 Orange/Black
	2	OUT2	
	3	DC(-)	Blue*1 Orange
	4	OUT1	
5	1	DC(+)	Brown*1 Red/Black
	2	OUT2	
	3	DC(-)	Blue*1 Red
	4	OUT1	
6	1	DC(+)	Brown*1 Green/Black
	2	OUT2	
	3	DC(-)	Blue*1 Green
	4	OUT1	

\*1 Brown and blue are connected inside the product.

### ISA-14 (Bracket when control unit not fitted)

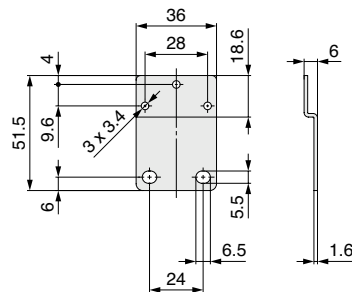

### Y200T-A (Spacer with bracket)

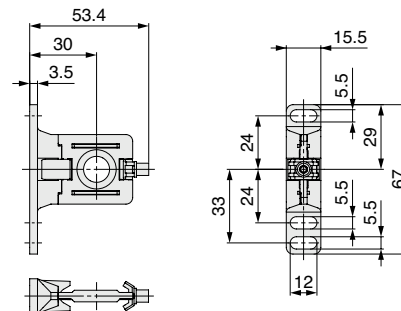

### ISA-17 (Bracket when control unit fitted)

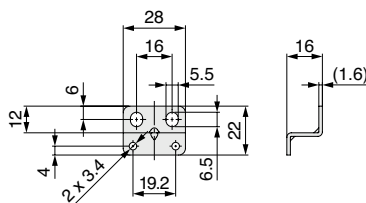

### ISA-20 (Bracket for centralized lead wire)

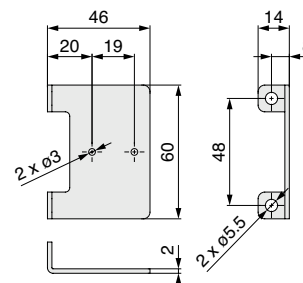

### Error Indication

Main screen	Name	Description	Measures
- - - -	Supply pressure error	Displayed when supply pressure is outside the range of 80 kPa to 220 kPa. Measurement is not possible.	Supply rated pressure (100 kPa to 200 kPa). The product will return to measurement mode automatically.
- - - -	Outside of the displayable range (Switch point change mode)	The workpiece is outside the displayable range.	Move the workpiece closer to the detection nozzle.
Er 1 oC1	OUT1 over current error	The switch output (OUT1) load current of 80 mA or more flows.	Turn the power OFF and remove the cause of the over current. Then turn the power ON again.
Er 2 oC2	OUT2 over current error	The switch output (OUT2) load current of 80 mA or more flows.	Turn the power OFF and remove the cause of the over current. Then turn the power ON again.
Er 3 ZEro	Zero clear error	Zero clear was not performed at atmospheric pressure. (Pressure outside of $\pm 14$ kPa was supplied present.)	Perform zero clear at atmospheric pressure.
Er 30 FSC2	Pressure adjustment error during calibration	Fine adjustment of the pressure display at the OUT port was not performed correctly during calibration. (When the pressure after the adjustment is below the supply pressure lower limit (80 kPa) or exceeds the display set range upper limit (220 kPa))	Keep the SUP port pressure and OUT port pressure the same and perform fine adjustment of the OUT port pressure display value. Set the pressure within 80 kPa to 220 kPa.
Er 0 Er 4 to Er 9 Er 40	System error	An internal data error has occurred.	Turn the power OFF and turn it ON again.
Er 15 V10	Version does not match	IO-Link version does not match that of the master. The master uses version 1.0.	Ensure that the master IO-Link version matches the device version.
Sub screen	Name	Description	Measures
HHH	Supply pressure error (When [SUP side pressure value display] is set to the sub screen)	Pressure exceeding 220 kPa is supplied.	Keep the supply pressure within the displayable range of -20 kPa to 220 kPa.
LLL		Vacuum pressure (less than -20 kPa) is supplied.	

### Relationship Between Supply Pressure and Display

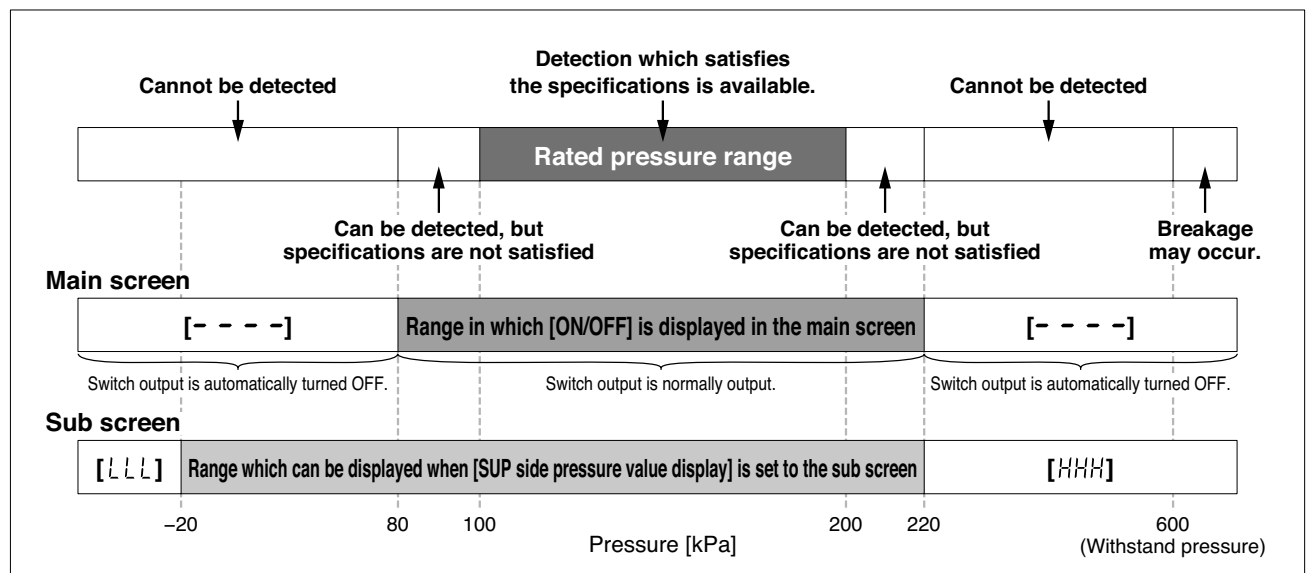

## Safety Instructions

These safety instructions are intended to prevent hazardous situations and/or equipment damage. These instructions indicate the level of potential hazard with the labels of “**Caution**,” “**Warning**” or “**Danger**.” They are all important notes for safety and must be followed in addition to International Standards (ISO/IEC)\*1), and other safety regulations.

 **Caution:** Caution indicates a hazard with a low level of risk which, if not avoided, could result in minor or moderate injury.

 **Warning:** Warning indicates a hazard with a medium level of risk which, if not avoided, could result in death or serious injury.

 **Danger:** Danger indicates a hazard with a high level of risk which, if not avoided, will result in death or serious injury.

\*1) ISO 4414: Pneumatic fluid power – General rules relating to systems.  
ISO 4413: Hydraulic fluid power – General rules relating to systems.  
IEC 60204-1: Safety of machinery – Electrical equipment of machines.  
(Part 1: General requirements)  
ISO 10218-1: Manipulating industrial robots – Safety.  
etc.

### Warning

#### 1. The compatibility of the product is the responsibility of the person who designs the equipment or decides its specifications.

Since the product specified here is used under various operating conditions, its compatibility with specific equipment must be decided by the person who designs the equipment or decides its specifications based on necessary analysis and test results. The expected performance and safety assurance of the equipment will be the responsibility of the person who has determined its compatibility with the product. This person should also continuously review all specifications of the product referring to its latest catalog information, with a view to giving due consideration to any possibility of equipment failure when configuring the equipment.

#### 2. Only personnel with appropriate training should operate machinery and equipment.

The product specified here may become unsafe if handled incorrectly. The assembly, operation and maintenance of machines or equipment including our products must be performed by an operator who is appropriately trained and experienced.

#### 3. Do not service or attempt to remove product and machinery/equipment until safety is confirmed.

1. The inspection and maintenance of machinery/equipment should only be performed after measures to prevent falling or runaway of the driven objects have been confirmed.
2. When the product is to be removed, confirm that the safety measures as mentioned above are implemented and the power from any appropriate source is cut, and read and understand the specific product precautions of all relevant products carefully.
3. Before machinery/equipment is restarted, take measures to prevent unexpected operation and malfunction.

#### 4. Contact SMC beforehand and take special consideration of safety measures if the product is to be used in any of the following conditions.

1. Conditions and environments outside of the given specifications, or use outdoors or in a place exposed to direct sunlight.
2. Installation on equipment in conjunction with atomic energy, railways, air navigation, space, shipping, vehicles, military, medical treatment, combustion and recreation, or equipment in contact with food and beverages, emergency stop circuits, clutch and brake circuits in press applications, safety equipment or other applications unsuitable for the standard specifications described in the product catalog.
3. An application which could have negative effects on people, property, or animals requiring special safety analysis.
4. Use in an interlock circuit, which requires the provision of double interlock for possible failure by using a mechanical protective function, and periodical checks to confirm proper operation.

### Caution

#### 1. The product is provided for use in manufacturing industries.

The product herein described is basically provided for peaceful use in manufacturing industries.  
If considering using the product in other industries, consult SMC beforehand and exchange specifications or a contract if necessary.  
If anything is unclear, contact your nearest sales branch.

### Limited warranty and Disclaimer/ Compliance Requirements

The product used is subject to the following “Limited warranty and Disclaimer” and “Compliance Requirements”.

Read and accept them before using the product.

#### Limited warranty and Disclaimer

1. The warranty period of the product is 1 year in service or 1.5 years after the product is delivered, whichever is first.\*2)  
Also, the product may have specified durability, running distance or replacement parts. Please consult your nearest sales branch.
2. For any failure or damage reported within the warranty period which is clearly our responsibility, a replacement product or necessary parts will be provided. This limited warranty applies only to our product independently, and not to any other damage incurred due to the failure of the product.
3. Prior to using SMC products, please read and understand the warranty terms and disclaimers noted in the specified catalog for the particular products.

##### \*2) Vacuum pads are excluded from this 1 year warranty.

A vacuum pad is a consumable part, so it is warranted for a year after it is delivered. Also, even within the warranty period, the wear of a product due to the use of the vacuum pad or failure due to the deterioration of rubber material are not covered by the limited warranty.

#### Compliance Requirements

1. The use of SMC products with production equipment for the manufacture of weapons of mass destruction (WMD) or any other weapon is strictly prohibited.
2. The exports of SMC products or technology from one country to another are governed by the relevant security laws and regulations of the countries involved in the transaction. Prior to the shipment of a SMC product to another country, assure that all local rules governing that export are known and followed.

### Caution

#### SMC products are not intended for use as instruments for legal metrology.

Measurement instruments that SMC manufactures or sells have not been qualified by type approval tests relevant to the metrology (measurement) laws of each country. Therefore, SMC products cannot be used for business or certification ordained by the metrology (measurement) laws of each country.







## UNIT CONVERSIONS

	unit	conversion	result
length	m	x 3.28	ft
	mm	x 0.04	in
mass	g	x 0.04	oz
volume	cm <sup>3</sup>	÷ 16.387	in <sup>3</sup>
	L	x 61.024	in <sup>3</sup>
speed	mm/s	÷ 25.4	in/s
pressure	MPa	x 145	psi
	kPa	÷ 6.895	psi
temperature	°C	x1.8 then add 32	°F
torque	N·m	x 0.738	ft·lb
force	N	÷ 4.448	lbf
flow	L/min	÷ 28.317	cfm

# Global Manufacturing, Distribution and Service Network

## Worldwide Subsidiaries

### EUROPE

**AUSTRIA**  
SMC Pneumatik GmbH (Austria)

**BELGIUM**  
SMC Pneumatics N.V./S.A.

**BULGARIA**  
SMC Industrial Automation Bulgaria EOOD

**CROATIA**  
SMC Industrijska Automatika d.o.o.

**CZECH REPUBLIC**  
SMC Industrial Automation CZ s.r.o.

**DENMARK**  
SMC Pneumatik A/S

**ESTONIA**  
SMC Pneumatics Estonia

**FINLAND**  
SMC Pneumatics Finland OY

**FRANCE**  
SMC Pneumatique S.A.

**GERMANY**  
SMC Pneumatik GmbH

**GREECE**  
SMC Hellas EPE

**HUNGARY**  
SMC Hungary Ipari Automatizálási Kft.

**IRELAND**  
SMC Pneumatics (Ireland) Ltd.

**ITALY**  
SMC Italia S.p.A.

**KAZAKHSTAN**  
LLP "SMC Kazakhstan"

**LATVIA**  
SMC Pneumatics Latvia SIA

**LITHUANIA**  
UAB "SMC Pneumatics"

**NETHERLANDS**  
SMC Pneumatics B.V.

**NORWAY**  
SMC Pneumatics Norway AS

**POLAND**  
SMC Industrial Automation Polska Sp. z o.o.

**ROMANIA**  
SMC Romania S.r.l.

**RUSSIA**  
SMC Pneumatik LLC.

**SLOVAKIA**  
SMC Priemyselná Automatizácia, Spol s.r.o.

**SLOVENIA**  
SMC Industrijska Avtomatika d.o.o.

**SPAIN / PORTUGAL**  
SMC España, S.A.

**SWEDEN**  
SMC Pneumatics Sweden AB

**SWITZERLAND**  
SMC Pneumatik AG

**TURKEY**  
SMC Pnömatik Sanayi Ticaret ve Servis A.Ş.

**UK**  
SMC Pneumatics (U.K.) Ltd.

### ASIA / OCEANIA

**AUSTRALIA**  
SMC Pneumatics (Australia) Pty. Ltd.

**CHINA**  
SMC (China) Co., Ltd.  
SMC Pneumatics (Guangzhou) Ltd.

**HONG KONG**  
SMC Pneumatics (Hong kong) Ltd.

**INDIA**  
SMC Pneumatics (India) Pvt. Ltd.

**INDONESIA**  
PT. SMC Pneumatics Indonesia

**JAPAN**  
SMC Corporation

**MALAYSIA**  
SMC Pneumatics (S.E.A.) Sdn. Bhd.

**NEW ZEALAND**  
SMC Pneumatics (N.Z.) Ltd.

**PHILIPPINES**  
Shoketsu SMC Corporation

**SINGAPORE**  
SMC Pneumatics (S.E.A.) Pte. Ltd.

**SOUTH KOREA**  
SMC Pneumatics Korea Co., Ltd.

**TAIWAN**  
SMC Pneumatics (Taiwan) Co., Ltd.

**THAILAND**  
SMC (Thailand) Ltd.

**UNITED ARAB EMIRATES**  
SMC Pneumatics Middle East FZE

**VIETNAM**  
SMC Pneumatics (VN) Co., Ltd

### AFRICA

**SOUTH AFRICA**  
SMC Pneumatics (South Africa) Pty Ltd

### NORTH, CENTRAL & SOUTH AMERICA

**ARGENTINA**  
SMC Argentina S.A.

**BOLIVIA**  
SMC Pneumatics Bolivia S.R.L.

**BRAZIL**  
SMC Pneumáticos do Brasil Ltda.

**CANADA**  
SMC Pneumatics (Canada) Ltd.

**CHILE**  
SMC Pneumatics (Chile) S.A.

**COLOMBIA**  
SMC Colombia Sucursal de SMC Chile, S.A.

**MEXICO**  
SMC Corporation (Mexico) S.A. de C.V.

**PERU**  
SMC Corporation Peru S.A.C.

**USA**  
SMC Corporation of America

**VENEZUELA**  
SMC Neumatica Venezuela S.A.

## U.S. & Canadian Sales Offices

### WEST

Austin  
Dallas  
Los Angeles  
Phoenix  
Portland  
San Jose

### CENTRAL

Chicago  
Cincinnati  
Cleveland  
Detroit  
Des Moines  
Grand Rapids  
Indianapolis  
Kansas City  
Milwaukee  
Minneapolis  
St. Louis

### EAST

Albany  
Atlanta  
Birmingham  
Boston  
Charlotte  
Knoxville  
Nashville  
New Jersey  
Rochester  
Tampa

### CANADA

Montreal  
Quebec City  
Toronto  
Vancouver  
Windsor

