



Wide Type Parallel Style Air Gripper

ø10, ø16, ø20, ø25 ø32, ø40

RoHS

Weight

Max. 10% reduction ø16, Opening/Closing stroke: 1.18 in (30 mm)
 20.64 oz (585 g) → **18.52 oz (525 g)**



Weight reduced by changing the body shape and internal construction

- **Dust-resistant option now available.**
(Made to order: -X85, -X86□)
- **Closing width adjusting option now available.**
(Made to order: -X28)
- **Small auto switches can be directly mounted.**
 - Mounting brackets are not required. This reduces assembly labor.
 - Direct mounting is now possible due to the new groove shape.
 - Solid state auto switch: D-M9□
- **Performance and mounting dimensions are interchangeable with the existing model.**



3 Types of Stroke Variations

[mm]

Opening/Closing stroke	Stroke					
	ø10	ø16	ø20	ø25	ø32	ø40
Short: MHL2-□D 	0.79	1.18	1.57	1.97	2.75	3.94
Medium: MHL2-□D1 	1.57	2.36	3.15	3.94	4.72	6.30
Long: MHL2-□D2 	2.36	3.15	3.94	4.72	6.30	7.87

New Added: ø32, ø40



MHL2 Series

Wide Type Parallel Style Air Gripper *MHL2 Series*

Lightweight

Lightweight body achieved by changing the body shape

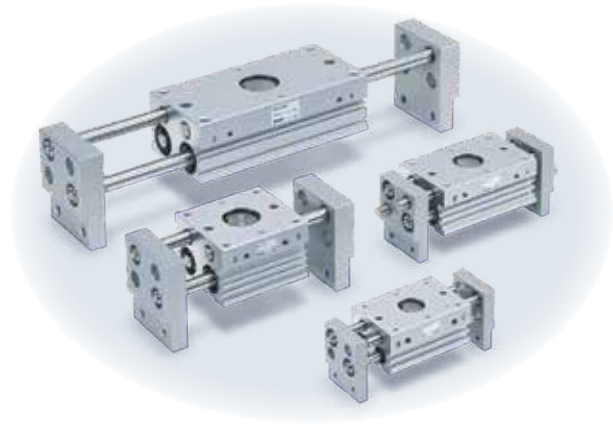

Model	MHL2-□Z	MHL2	Reduction rate
MHL2-10D	280	280	0.0%
MHL2-16D	525	585	10.3%
MHL2-20D	940	1025	8.3%
MHL2-25D	1565	1690	7.4%
MHL2-32D	2875	2905	1.0%
MHL2-40D	5230	5270	1.0%

Built-in dust protection mechanism (Standard)

All rod rotating parts now feature a scraper with a dust lip.

Dust-resistant option now available. (Made to order) Pages 21 to 24

- In micro-powder (10 to 100 μm) environments → With double Lube-retainer (-X85)
 - * Prevents particles and foreign matter from entering the gripper
 - The Lube-retainer ensures a consistent film of grease, improving gripper endurance.
- In dusty environments → With heavy duty scraper + Lube-retainer (-X86□)
 - * Applicable for environments containing particles or foreign matter
 - A grease film is formed on the rod by the Lube-retainer in order to improve endurance.
 - * Seal material can be NBR or fluororubber.

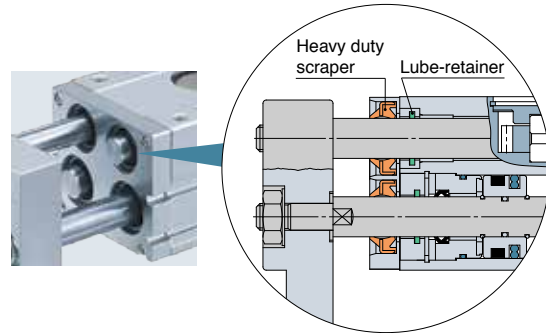
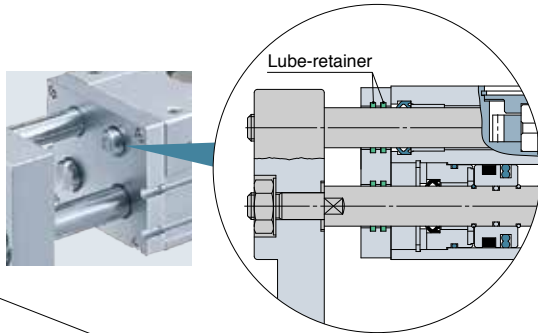

Fingers synchronized by a rack and pinion mechanism

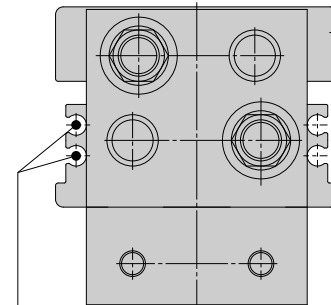
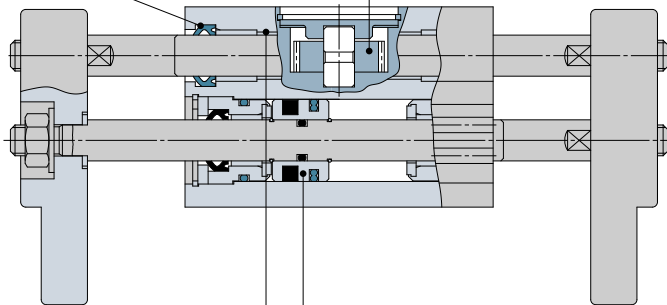

Double-end type oil-impregnated resin bearings are used for all shafts.

A large amount of gripping force is provided, through the use of a double piston mechanism, while maintaining a compact design.

An auto switch can be mounted in 4 locations.

Series Variations

Series	Action	Bore size [mm]						Made to order
		10	16	20	25	32	40	
MHL2-□Z	Double acting	●	●	●	●	●	●	-X4: Heat resistant (-10 to 100°C) -X5: Fluororubber seal -X28: With bolt for adjusting the closing width -X50: Without magnet -X53: Ethylene propylene rubber seal (EPDM) -X63: Fluorine grease -X79: Grease for food processing machines: Fluorine grease -X79A: Grease for food processing machines: Aluminum complex soap base grease -X85: Fine-particle proof specification (MHL2-□Z only) -X86: With heavy duty scraper + Stable lubrication function (Lube-retainer) (NBR seals) (MHL2-□Z only) -X86A: With heavy duty scraper + Stable lubrication function (Lube-retainer) (Fluororubber seals) (MHL2-□Z only)

CONTENTS

Wide Type Parallel Style Air Gripper *MHL2 Series*

How to Order	Page 3
Specifications	Page 4
Model Selection	Page 5
Construction	Page 7
Dimensions	Pages 8 to 13
Auto Switch Installation Examples and Mounting Positions	Pages 14, 15
Auto Switch Hysteresis	Page 15
Prior to Use Auto Switch Connections and Examples	Page 16
Made to Order	Pages 17 to 24
Specific Product Precautions	Page 25
Safety Instructions	Back cover

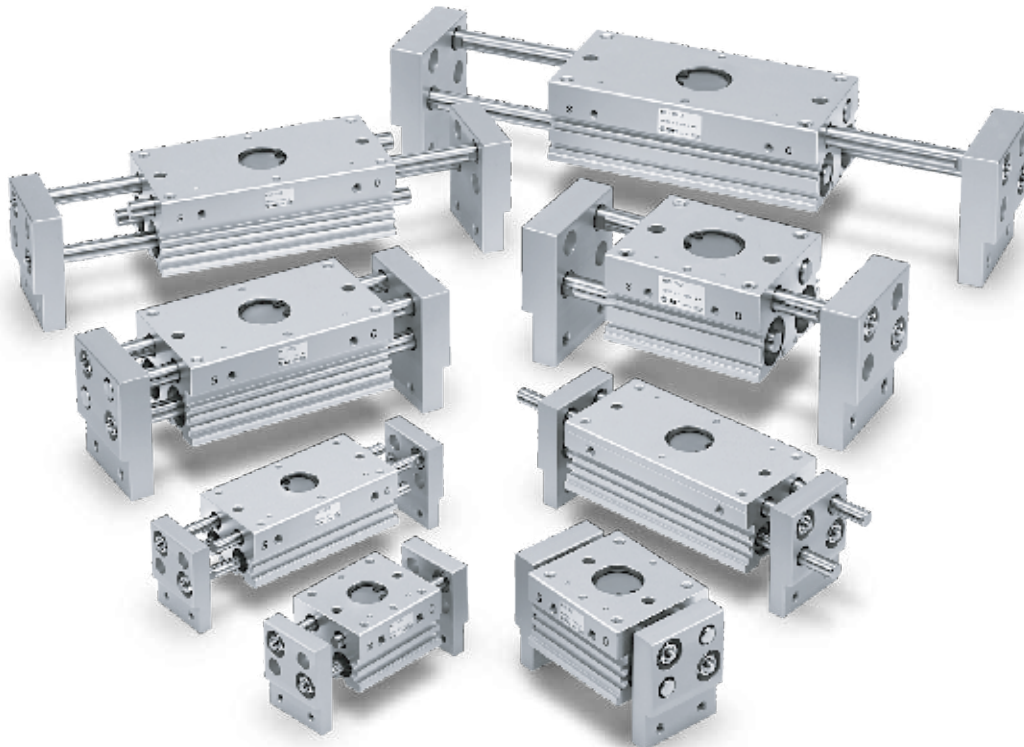

How to Order

MHL2-16-D-Z-M9BW

Wide type

Number of fingers

2	2
---	---

Bore size

10	10 mm
16	16 mm
20	20 mm
25	25 mm
32	32 mm
40	40 mm

Port thread type

Symbol	Type	Cylinder bore
Nil	M thread	ø10 to ø25
	Rc	
TN	NPT	ø32 to ø40
TF	G	

Action

D	Double acting
---	---------------

Made to order
Refer to page 4 for details.

Number of auto switches

Nil	2
S	1
n	n

Auto switch

Nil	Without auto switch (Built-in magnet)
-----	---------------------------------------

* For applicable auto switches, refer to the table below.

Opening/Closing stroke [mm]

Symbol	ø10	ø16	ø20	ø25	ø32	ø40
Short: MHL2-□D	20	30	40	50	70	100
Medium: MHL2-□D1	40	60	80	100	120	160
Long: MHL2-□D2	60	80	100	120	160	200

Applicable Auto Switches/Refer to the **Web Catalog** or Best Pneumatics for further information on auto switches.

Type	Special function	Electrical entry	Indicator/light	Wiring (Output)	Load voltage		Auto switch model		Lead wire length [m] ^{*1}				Pre-wired connector	Applicable load	
					DC	AC	Perpendicular	In-line	0.5 (Nil)	1 (M)	3 (L)	5 (Z)			
Solid state auto switch	—	Grommet	Yes	3-wire (NPN)	24 V	5 V, 12 V	—	M9NV	M9N	●	●	●	○	○	Relay, PLC
				3-wire (PNP)				M9PV	M9P	●	●	●	○	○	
				2-wire	M9BV	M9B	●	●	●	○	○				
				3-wire (NPN)	M9NVV	M9NV	●	●	●	○	○				
	3-wire (PNP)			M9PVV	M9PV	●	●	●	○	○					
	2-wire			M9BVV	M9BV	●	●	●	○	○					
	3-wire (NPN)			M9NAV ^{*2}	M9NA ^{*2}	○	○	●	○	○					
	3-wire (PNP)			M9PAV ^{*2}	M9PA ^{*2}	○	○	●	○	○					
	2-wire			M9BAV ^{*2}	M9BA ^{*2}	○	○	●	○	○					

*1 Lead wire length symbols: 0.5 m..... Nil (Example) M9NW
 1 m..... M (Example) M9NWM
 3 m..... L (Example) M9NWL
 5 m..... Z (Example) M9NWZ

*2 Water resistant type auto switches can be mounted on the above models, but SMC cannot guarantee water resistance.
 * Solid state auto switches marked with "O" are produced upon receipt of order.
 * When using the 2-color indicator type, please make the setting so that the indicator is lit in red to ensure the detection at the proper position of the air gripper.

Wide Type Parallel Style Air Gripper *MHL2 Series*

Long stroke

One unit can handle workpieces with various diameters.

A large amount of gripping force is provided, through the use of a double piston mechanism, while maintaining a compact design.

Double-end type oil-impregnated resin bearings are used for all shafts.

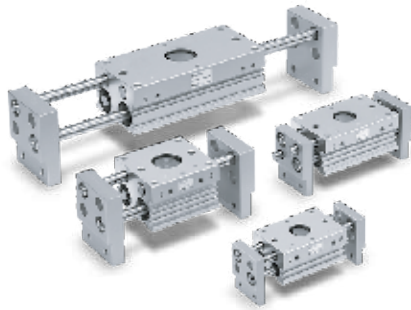

Symbol

Double acting: Internal grip Double acting: External grip

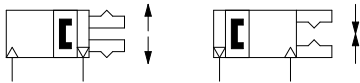

Made to Order

(For details, refer to pages 17 to 24.)

Symbol	Specifications
-X4	Heat resistant (-10 to 100°C)
-X5	Fluororubber seal
-X28	With bolt for adjusting the closing width
-X50	Without magnet
-X53	Ethylene propylene rubber seal (EPDM)
-X63	Fluorine grease
-X79	Grease for food processing machines: Fluorine grease
-X79A	Grease for food processing machines: Aluminum complex soap base grease
-X85	Fine-particle proof specification
-X86	With heavy duty scraper + Stable lubrication function (Lube-retainer) (Seal material: NBR, Fluororubber)

Refer to pages 14 and 15 for cylinders with auto switches.

- Auto Switch Installation Examples and Mounting Positions
- Auto Switch Hysteresis

Specifications

Bore size [mm]	10	16	20	25	32	40
Fluid	Air					
Action	Double acting					
Operating pressure [MPa]	0.15 to 0.6		0.1 to 0.6			
Ambient and fluid temperatures	-10 to 60°C (No freezing)					
Repeatability	±0.1					
Lubricant	Non-lube					
Effective gripping force [N]*1 at 0.5 MPa	14	45	74	131	228	396

*1 Gripping point distance = Bore size 10, 16, 20, 25: 40 mm, Bore size 32, 40: 80 mm

Model/Stroke

Model	Bore size [mm]	Max. operating frequency [c.p.m]	Opening/Closing stroke [mm] (L2-L1)	Closing width [mm] (L1)	Opening width [mm] (L2)	Weight [g]
MHL2-10DZ	10	60	20	56	76	280
MHL2-10D1Z		40	40	78	118	355
MHL2-10D2Z			60	96	156	430
MHL2-16DZ	16	60	30	68	98	525
MHL2-16D1Z		40	60	110	170	725
MHL2-16D2Z			80	130	210	845
MHL2-20DZ	20	60	40	82	122	940
MHL2-20D1Z		40	80	142	222	1335
MHL2-20D2Z			100	162	262	1520
MHL2-25DZ	25	60	50	100	150	1565
MHL2-25D1Z		40	100	182	282	2295
MHL2-25D2Z			120	200	320	2525
MHL2-32DZ	32	30	70	150	220	2875
MHL2-32D1Z		20	120	198	318	3770
MHL2-32D2Z			160	242	402	4585
MHL2-40DZ	40	30	100	188	288	5230
MHL2-40D1Z		20	160	246	406	6760
MHL2-40D2Z			200	286	486	7825

* The opening and closing widths represent the value when gripping the exterior of a workpiece.

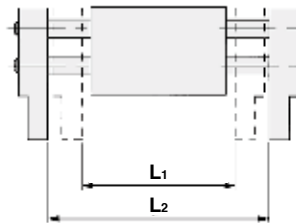

⚠ Specific Product Precautions

Be sure to read this before handling the products. Refer to page 25 for details.

Wide Type Parallel Style Air Gripper MHL2 Series

Model Selection

Step 1 Check the gripping force. → **Step 2** Check the gripping point.

Step 1 Check the gripping force.

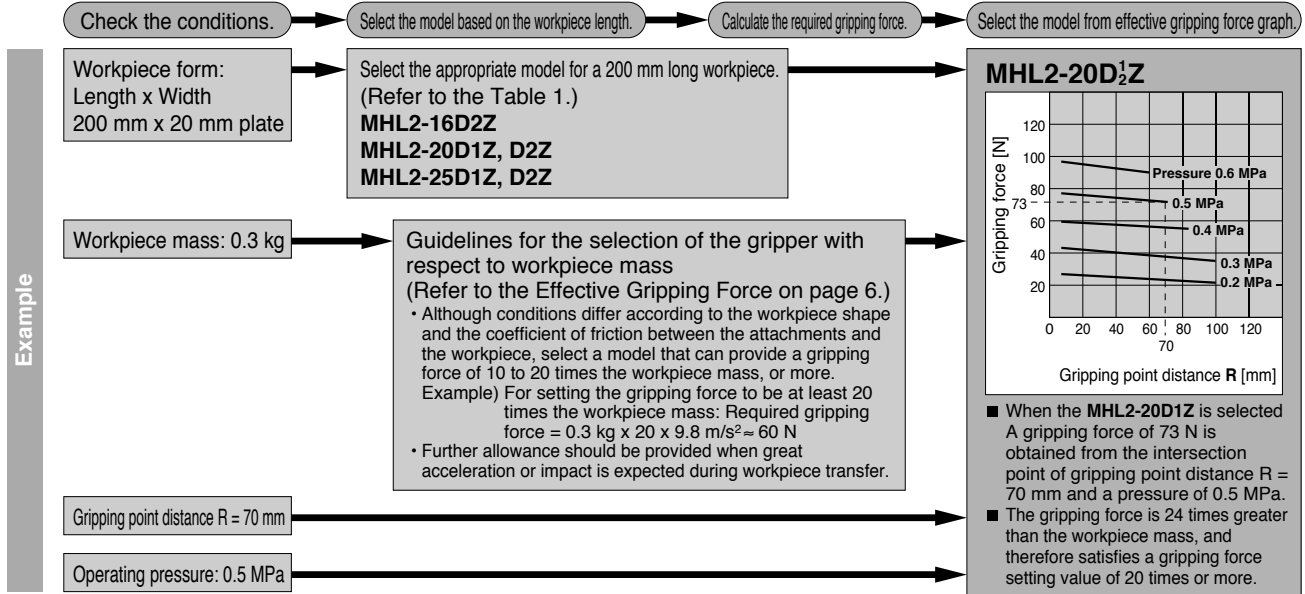
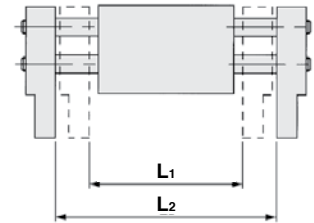

Table 1

Model	Bore size [mm]	Closing width [mm] (L1)	Opening width [mm] (L2)	Model	Bore size [mm]	Closing width [mm] (L1)	Opening width [mm] (L2)
MHL2-10DZ	10	56	76	MHL2-25DZ	25	100	150
MHL2-10D1Z		78	118	MHL2-25D1Z		182	282
MHL2-10D2Z		96	156	MHL2-25D2Z		200	320
MHL2-16DZ	16	68	98	MHL2-32DZ	32	150	220
MHL2-16D1Z		110	170	MHL2-32D1Z		198	318
MHL2-16D2Z		130	210	MHL2-32D2Z		242	402
MHL2-20DZ	20	82	122	MHL2-40DZ	40	188	288
MHL2-20D1Z		142	222	MHL2-40D1Z		246	406
MHL2-20D2Z		162	262	MHL2-40D2Z		286	486



* The opening and closing widths represent the value when gripping the exterior of a workpiece.

Calculation of Required Gripping Force

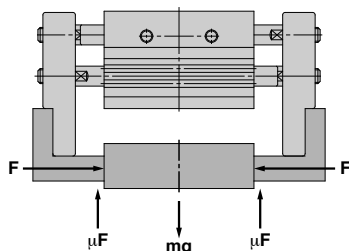

“Gripping force at least 10 to 20 times the workpiece weight”

• The “10 to 20 times or more of the workpiece weight” recommended by SMC is calculated with a margin of “a” = 4, which allows for impacts that occur during normal transportation, etc.

When $\mu = 0.2$	When $\mu = 0.1$
$F = \frac{mg}{2 \times 0.2} \times 4$ $= 10 \times mg$	$F = \frac{mg}{2 \times 0.1} \times 4$ $= 20 \times mg$

10 x Workpiece weight

20 x Workpiece weight

When gripping a workpiece as in the figure to the left, and with the following definitions,

- F** Gripping force [N]
- μ Coefficient of friction between the attachments and the workpiece
- m** Workpiece mass [kg]
- g** Gravitational acceleration (= 9.8 m/s²)
- mg**: Workpiece weight [N]

the conditions under which the workpiece will not drop are

$$2 \times \mu F > mg$$

Number of fingers

and therefore,

$$F > \frac{mg}{2 \times \mu}$$

With “a” representing the margin, “F” is determined by the following formula:

$$F = \frac{mg}{2 \times \mu} \times a$$

- Even in cases where the coefficient of friction is greater than $\mu = 0.2$, for reasons of safety, select a gripping force which is at least 10 to 20 times greater than the workpiece weight, as recommended by SMC.
- If high acceleration or impact forces are encountered during motion, a further margin should be considered.

Model Selection

Effective Gripping Force

- **Indication of effective gripping force**

The gripping force shown in the tables represents the gripping force of one finger when all fingers and attachments are in contact with the workpiece.

F = One finger thrust

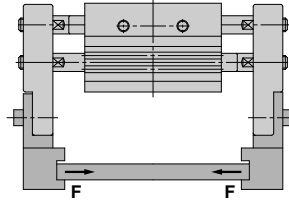

MHL2-10DZ

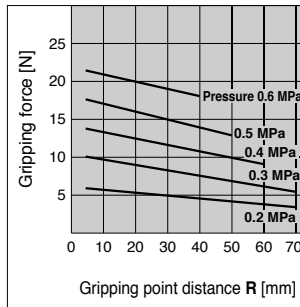

MHL2-10D₁Z

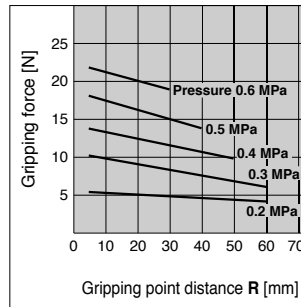

MHL2-16DZ

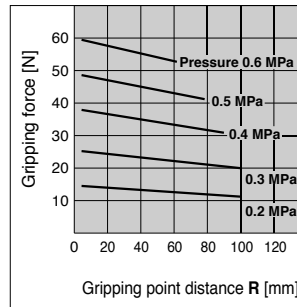

MHL2-16D₁Z

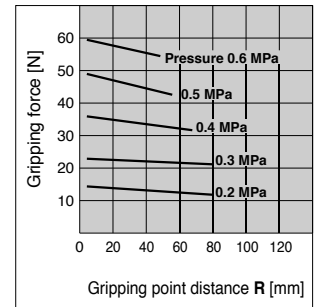

MHL2-20DZ

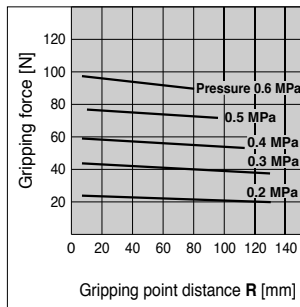

MHL2-20D₁Z

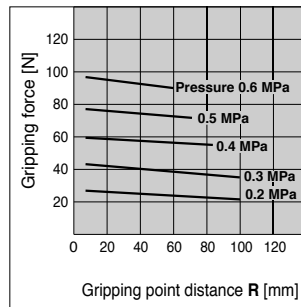

MHL2-25DZ

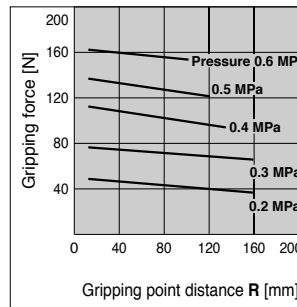

MHL2-25D₁Z

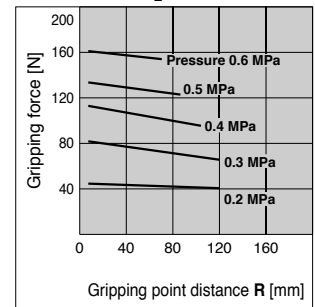

MHL2-32DZ

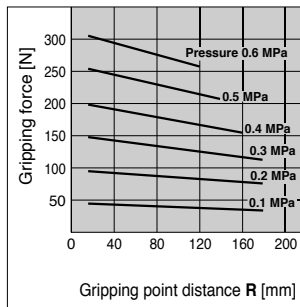

MHL2-32D₁Z

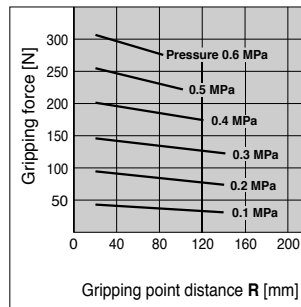

MHL2-40DZ

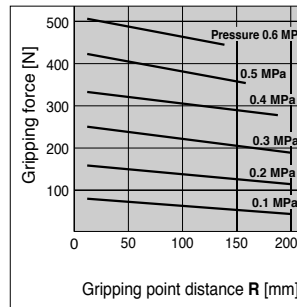

MHL2-40D₁Z

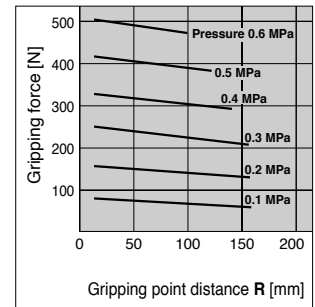

Step 2 Check the gripping point.

- The workpiece gripping point distance should be within the gripping force ranges given for each pressure in the effective gripping force graphs above.
- If operated with the workpiece gripping point beyond the indicated ranges, the load that will be applied to the fingers or the guide will become excessively unbalanced. As a result, the fingers could become loosened and adversely affect the service life of the unit.

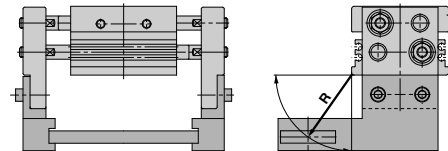

R: Gripping point distance [mm]

Wide Type Parallel Style Air Gripper *MHL2 Series*

Construction

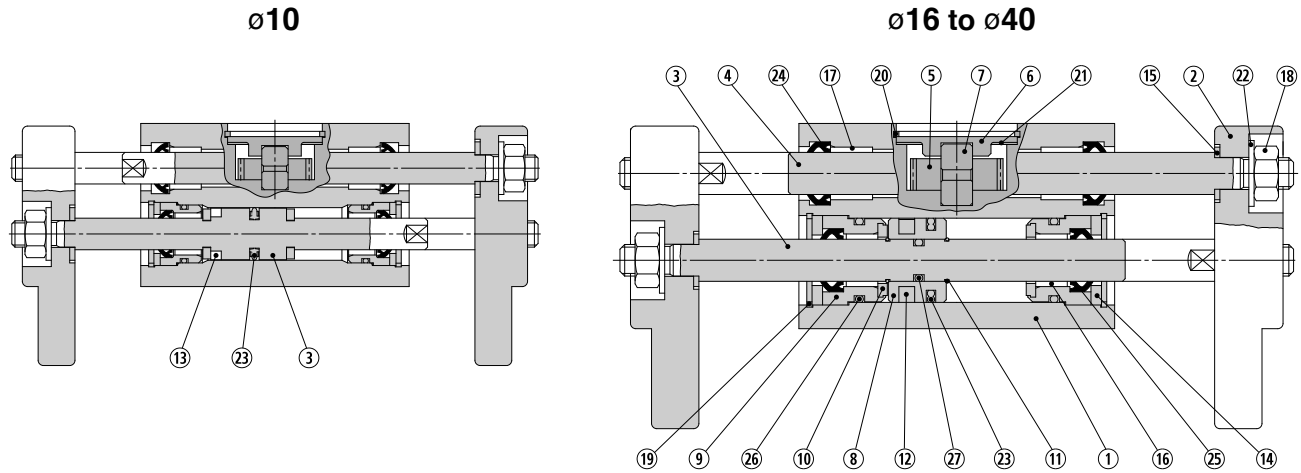

Component Parts

No.	Description	Material	Note
1	Body	Aluminum alloy	Hard anodized
2	Finger	Aluminum alloy	Hard anodized
3	Piston rod	Stainless steel	
4	Rack	Stainless steel	
5	Pinion	Carbon steel	
6	Pinion cover	Carbon steel	Electroless nickel plating
7	Pinion axis	Stainless steel	
8	Piston	Aluminum alloy	Hard anodized
9	Rod cover	Aluminum alloy	Trivalent chromated
10	Bumper	Urethane rubber	
11	Clip	Stainless steel spring wire	
12	Rubber magnet	Synthetic rubber	
13	Magnet	—	Nickel plating
14	Rod seal cover B	Cold rolled carbon steel sheet	Electroless nickel plating

No.	Description	Material	Note
15	Washer	Stainless steel	
16	Bearing	Oil containing polyacetal	
17	Bearing	Oil containing polyacetal	
18	U-nut	Carbon steel	Trivalent chromated
19	Inverted internal retaining ring	Carbon steel	Phosphate coating
20	C type retaining ring	Carbon steel	Phosphate coating
21	Wave washer	Steel for spring	Phosphate coating
22	Conical spring washer	Carbon steel	
23	Piston seal	NBR	
24	Rod seal	NBR	
25	Rod seal	NBR	
26	Gasket	NBR	
27	Gasket	NBR	

Replacement Parts

Description	MHL2-10□Z	MHL2-16□Z	MHL2-20□Z	MHL2-25□Z	MHL2-32□Z	MHL2-40□Z	Contents	
Seal kit	MHL10-PS	MHL16-PS	MHL20-PS	MHL25-PS	MHL32-PS	MHL40-PS	23, 24, 25, 26, 27	
Piston assembly	MHL2-□□DZ	MHL-AA1001	MHL-AA1601	MHL-AA2001	MHL-AA2501	MHL-AA3201	MHL-AA4001	ø10: 3, 10, 13, 23
	MHL2-□□D1Z	MHL-AA1002	MHL-AA1602	MHL-AA2002	MHL-AA2502	MHL-AA3202	MHL-AA4002	ø16 to ø40: 3, 8, 11, 12, 23,
	MHL2-□□D2Z	MHL-AA1003	MHL-AA1603	MHL-AA2003	MHL-AA2503	MHL-AA3203	MHL-AA4003	27
Rack	MHL2-□□DZ	MHL-AA1004	MHL-AA1604	MHL-AA2004	MHL-AA2504	MHL-AA3204	MHL-AA4004	4
	MHL2-□□D1Z	MHL-AA1005	MHL-AA1605	MHL-AA2005	MHL-AA2505	MHL-AA3205	MHL-AA4005	
	MHL2-□□D2Z	MHL-AA1006	MHL-AA1606	MHL-AA2006	MHL-AA2506	MHL-AA3206	MHL-AA4006	
Rod cover assembly	MHL-AA1007	MHL-AA1607	MHL-AA2007	MHL-AA2507	MHL-AA3207	MHL-AA4007	ø10: 9, 14, 16, 19, 25, 26 ø16 to ø40: 9, 10, 14, 16, 19, 25, 26	
Finger assembly	MHL-AA1008	MHL-AA1608	MHL-AA2008	MHL-AA2508	MHL-AA3208	MHL-AA4008	2, 15, 18, 22	
Pinion assembly	MHL-AA1009	MHL-AA1609	MHL-AA2009	MHL-AA2509	MHL-AA3209	MHL-AA4009	5, 6, 7, 20, 21	
Nut set	MHL-A1017	MHL-A1617	MHL-A2017	MHL-A2517	MHL-A3217	MHL-A4017	15, 18, 22	
U-nut assembly	MHL-A1017A	MHL-A1617A	MHL-A2017A	MHL-A2517A	MHL-A3217A	MHL-A4017A	18, 22	

- * Order one finger assembly, pinion assembly, nut set and U-nut assembly per unit.
- * For piston assembly and rack, order 2 pieces per unit.
- * For rod cover assembly, order 4 pieces per unit.
- * The seal kit does not include a grease pack. Order it separately.

Replacement Parts/Grease Pack Part Nos.

MHL2-□□DZ (ø10 to ø20)	GR-S-010 (10 g)
MHL2-□□DZ (ø25, ø32)	GR-S-010 (10 g)
MHL2-□□DZ (ø40)	GR-S-020 (20 g)
MHL2-□□D1Z (ø10, ø16)	GR-S-010 (10 g)
MHL2-□□D1Z (ø20, ø25)	GR-S-010 (10 g)
MHL2-□□D1Z (ø32, ø40)	GR-S-020 (20 g)
MHL2-□□D2Z (ø10, ø16)	GR-S-010 (10 g)
MHL2-□□D2Z (ø20, ø25)	GR-S-010 (10 g)
MHL2-□□D2Z (ø32, ø40)	GR-S-010 (10 g), GR-S-020 (20 g) (1 pack each)

Wide Type Parallel Style Air Gripper *MHL2 Series*

Dimensions

MHL2-10D□Z

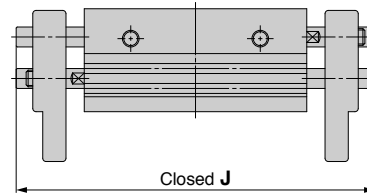
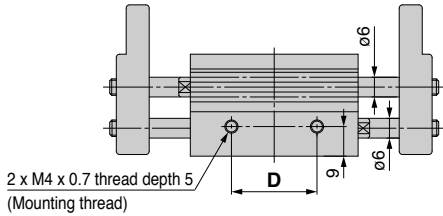

View K (Fingers closed)

* The above figure shows the MHL2-10D1Z/10D2Z.

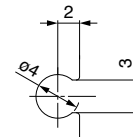
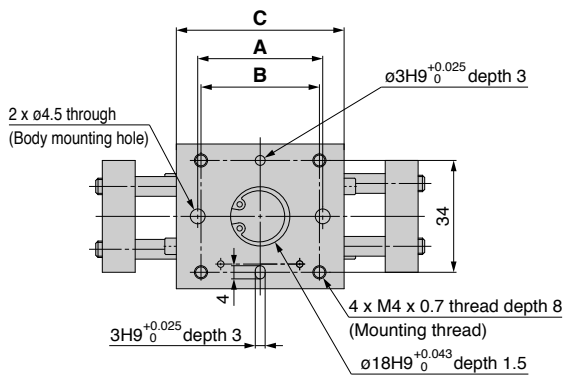

***1 Dimensions of auto switch mounting groove (Enlarged view)**

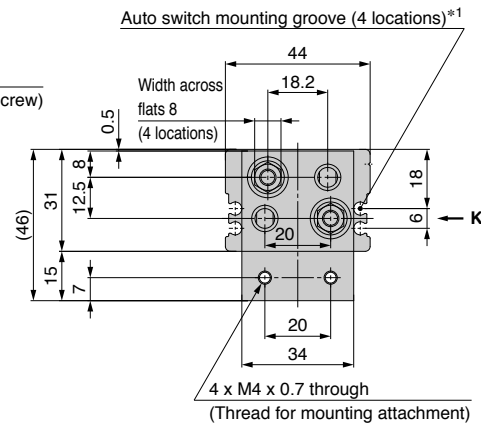
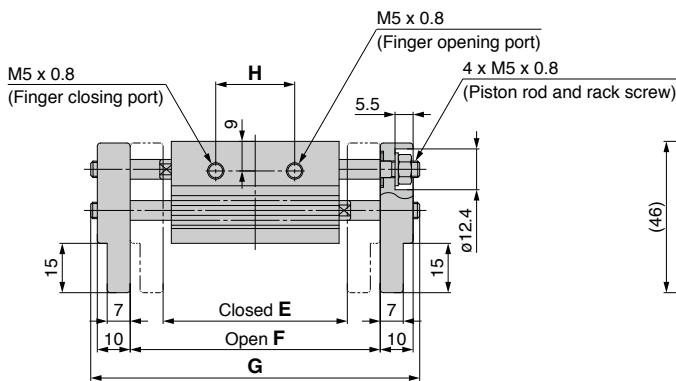

Model	A	B	C	D	E	F	G	H	J
MHL2-10DZ	38	36	51	26	56	76	100	24	80
MHL2-10D1Z	54	52	67	42	78	118	142	39	108
MHL2-10D2Z	72	70	85	60	96	156	180	57	146

* J-dimension is at fully closed.

* D1Z is different from D2Z at finger closed because shaft is ejected from finger end.
J-dimension is different from the value which is subtracted stroke from G-dimension.

Wide Type Parallel Style Air Gripper *MHL2 Series*

Dimensions

MHL2-16D□Z

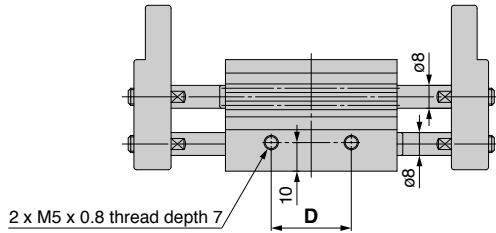

2 x M5 x 0.8 thread depth 7
(Mounting thread)

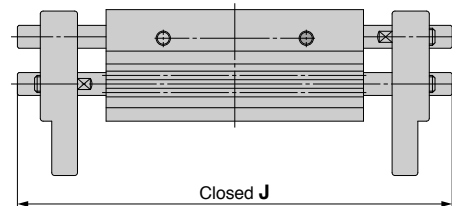

View K (Fingers closed)

* The above figure shows the MHL2-16D1Z/16D2Z.

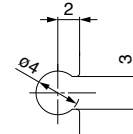
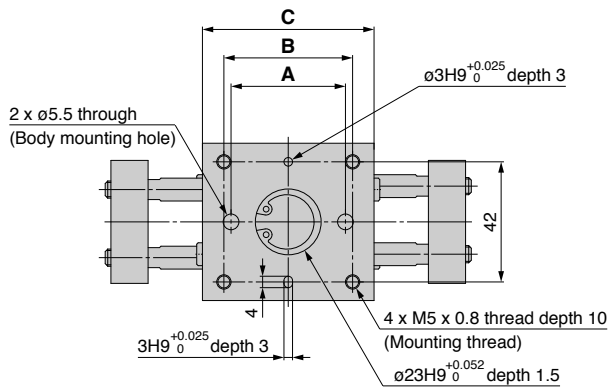

*1 Dimensions of auto switch mounting groove (Enlarged view)

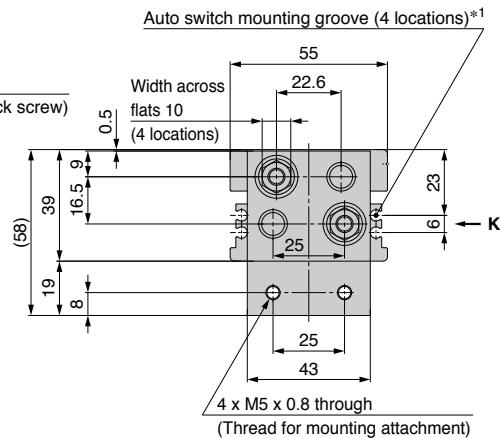
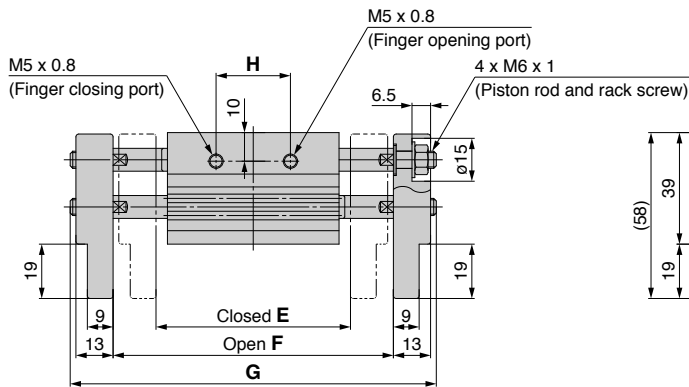

Model	A	B	C	D	E	F	G	H	J
MHL2-16DZ	40	45	60	28	68	98	128	26	98
MHL2-16D1Z	70	75	90	58	110	170	200	50	152
MHL2-16D2Z	90	95	110	78	130	210	240	70	192

* J-dimension is at fully closed.
 * D1Z is different from D2Z at finger closed because shaft is ejected from finger end.
 J-dimension is different from the value which is subtracted stroke from G-dimension.

Wide Type Parallel Style Air Gripper *MHL2 Series*

Dimensions

MHL2-25D□Z

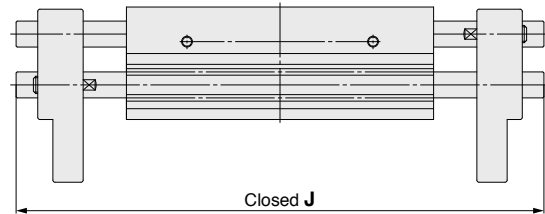
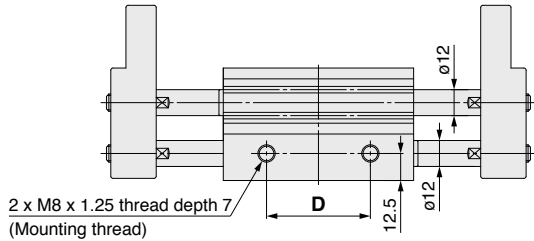

View K (Fingers closed)

* The above figure shows the MHL2-25D1Z/25D2Z.

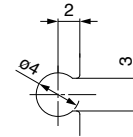
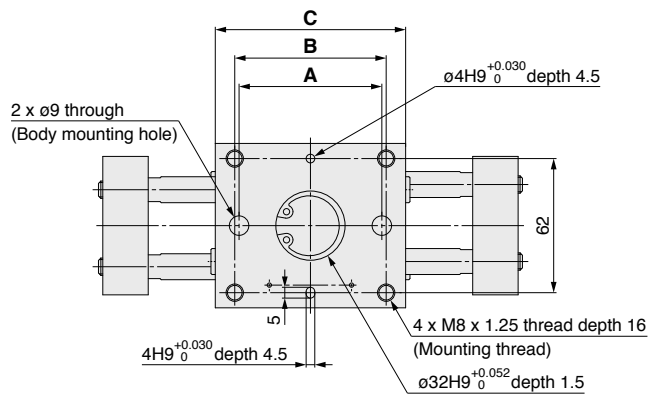

***1 Dimensions of auto switch mounting groove (Enlarged view)**

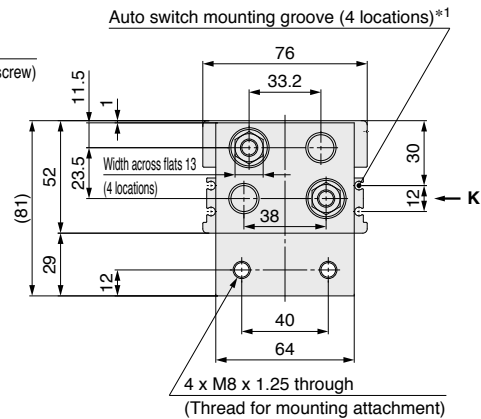
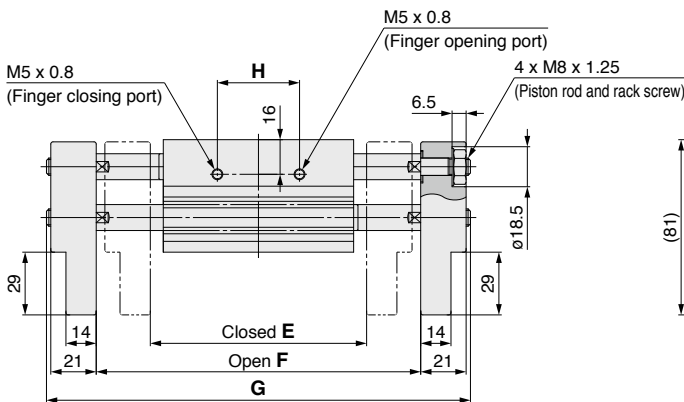

Model	A	B	C	D	E	F	G	H	J
MHL2-25DZ	66	70	88	48	100	150	196	38	146
MHL2-25D1Z	120	124	142	102	182	282	328	86	244
MHL2-25D2Z	138	142	160	120	200	320	366	104	282

* J-dimension is at fully closed.

* D1Z is different from D2Z at finger closed because shaft is ejected from finger end.
J-dimension is different from the value which is subtracted stroke from G-dimension.

Wide Type Parallel Style Air Gripper *MHL2 Series*

Dimensions

MHL2-32D□Z

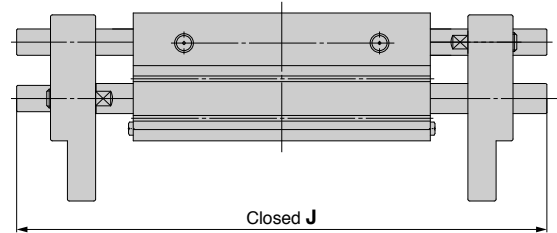
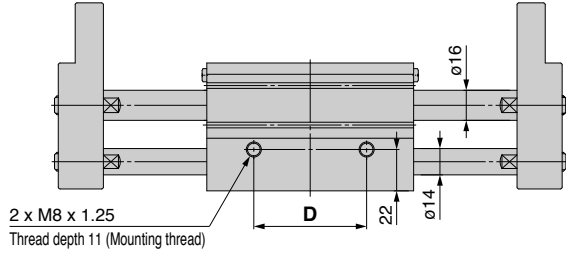

View K (Fingers closed)

* The above figure shows the MHL2-32D1Z/32D2Z.

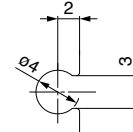
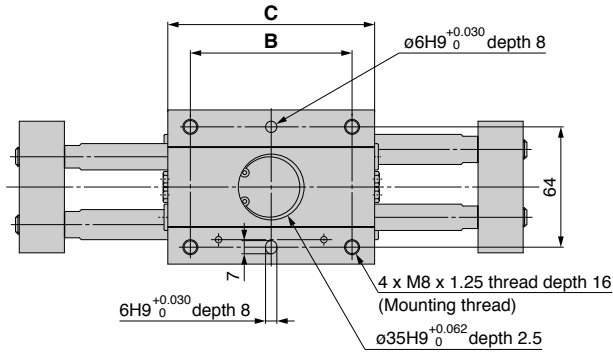

***1 Dimensions of auto switch mounting groove (Enlarged view)**

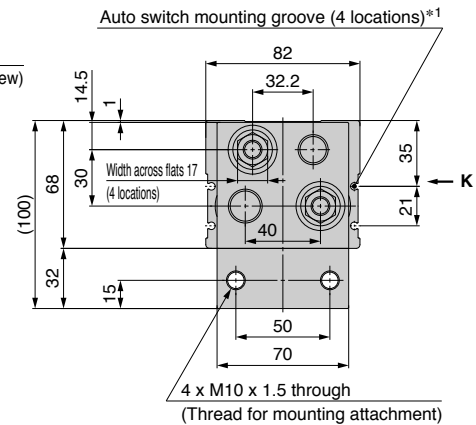
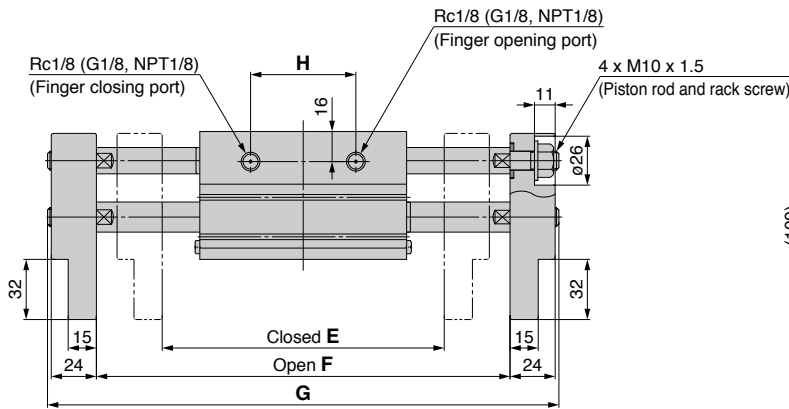

Model	B	C	D	E	F	G	H	J
MHL2-32DZ	86	110	60	150	220	272	56	202
MHL2-32D1Z	134	158	108	198	318	370	104	282
MHL2-32D2Z	178	202	152	242	402	454	148	366

* J-dimension is at fully closed.

* D1Z is different from D2Z at finger closed because shaft is ejected from finger end.

J-dimension is different from the value which is subtracted stroke from G-dimension.

Wide Type Parallel Style Air Gripper *MHL2 Series*

Dimensions

MHL2-40D□Z

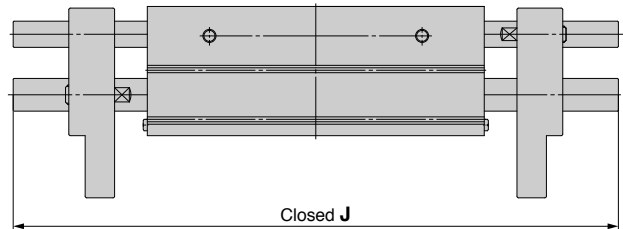
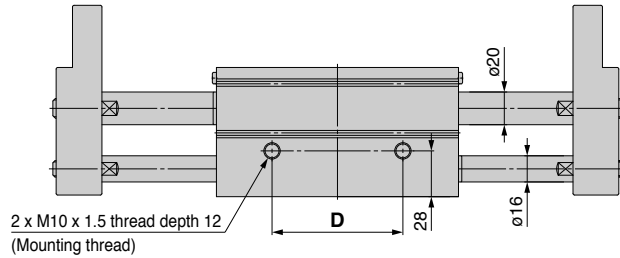

View K (Fingers closed)

* The above figure shows the MHL2-40D1Z/40D2Z.

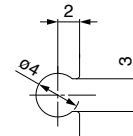
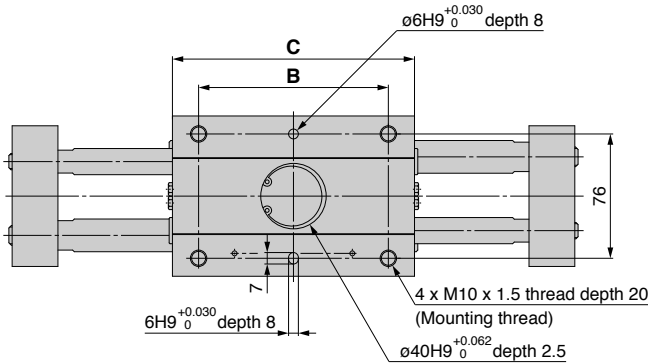

***1 Dimensions of auto switch mounting groove (Enlarged view)**

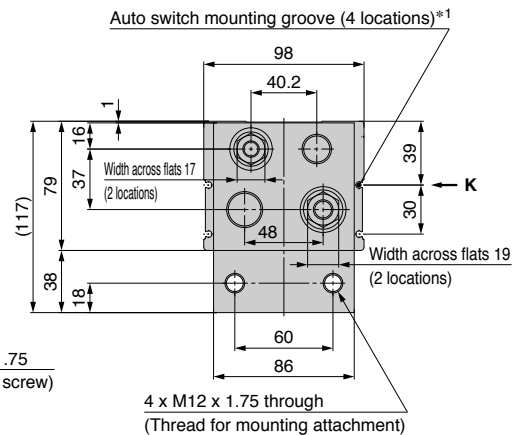
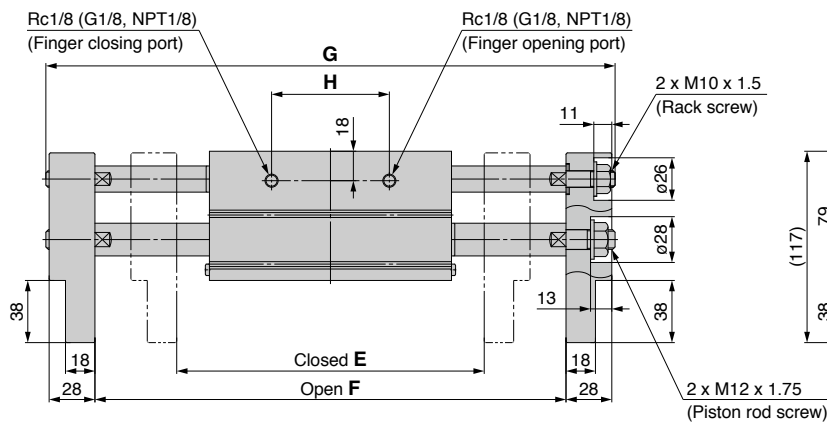

Model	B	C	D	E	F	G	H	J
MHL2-40DZ	116	148	80	188	288	348	72	252
MHL2-40D1Z	174	206	138	246	406	466	130	370
MHL2-40D2Z	214	246	178	286	486	546	170	450

* J-dimension is at fully closed.

* D1Z is different from D2Z at finger closed because shaft is ejected from finger end.



J-dimension is different from the value which is subtracted stroke from G-dimension.

MHL2 Series

Auto Switch Installation Examples and Mounting Positions

Various auto switch applications are possible through different combinations of auto switch quantities and detecting positions.

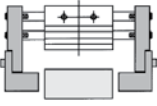
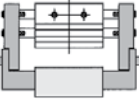
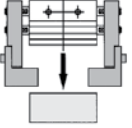
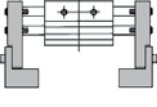
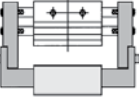
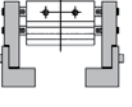
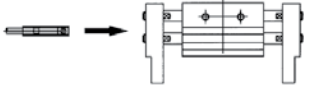
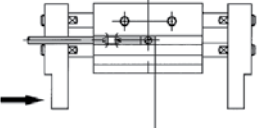
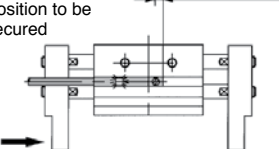
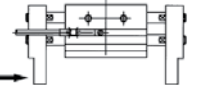
1) Detection when Gripping Exterior of Workpiece

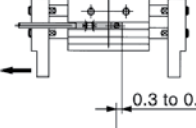
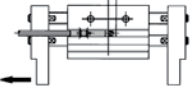
Detection example		① Confirmation of fingers in reset position	② Confirmation of workpiece held	③ Confirmation of workpiece released
Position to be detected		Position of fingers fully open 	Position when gripping a workpiece 	Position of fingers fully closed 
Operation of auto switch		When fingers return: Auto switch to turn ON (Light ON)	When gripping a workpiece: Auto switch to turn ON (Light ON)	When a workpiece is not held (Abnormal operation): Auto switch to turn ON (Light ON)
Detection combinations	One auto switch * One position, any of ①, ② and ③ can be detected.	●	●	●
	Two auto switches * Two positions of ①, ② and ③ can be detected.	●	●	—
		—	●	●
Pattern	A	●	—	—
	B	—	●	●
	C	●	—	●
How to determine auto switch installation position		Step 1) Fully open the fingers. 	Step 1) Position fingers for gripping a workpiece. 	Step 1) Fully close the fingers. 
At no pressure or low pressure, connect the auto switch to a power supply, and follow the directions.		Step 2) Insert the auto switch into the auto switch mounting groove from the direction of the arrow. 		
		Step 3) Slide the auto switch in the direction of the arrow until the indicator light illuminates and fasten it at a position 0.3 to 0.5 mm in the direction of the arrow beyond the position where the indicator light illuminates. Position where light turns ON  Position to be secured 	Step 3) Slide the auto switch in the direction of the arrow until the indicator light illuminates. 	Step 4) Slide the auto switch further in the direction of the arrow until the indicator light goes out. 
		Step 5) Slide the auto switch in the opposite direction and fasten it at a position 0.3 to 0.5 mm beyond the position where the indicator light illuminates. Position where light turns ON  Position to be secured 		





- * It is recommended that gripping of a workpiece be performed close to the center of the finger stroke.
- * When holding a workpiece close at the end of opening/closing stroke of fingers, detecting performance of the combinations listed in the above table may be limited, depending on the hysteresis of an auto switch, etc.

MHL2 Series

Auto Switch Installation Examples and Mounting Positions

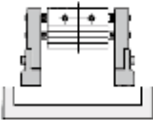
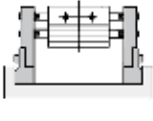
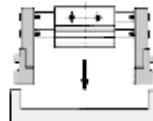
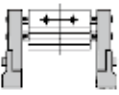
Various auto switch applications are possible through different combinations of auto switch quantities and detecting positions.

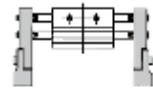
2) Detection when Gripping Interior of Workpiece

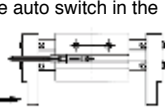
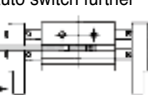
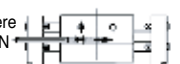
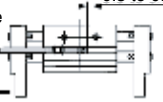
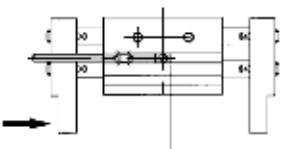
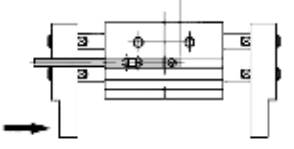
Detection example		① Confirmation of fingers in reset position	② Confirmation of workpiece held	③ Confirmation of workpiece released
Position to be detected		Position of fingers fully closed 	Position when gripping a workpiece 	Position of fingers fully open 
Operation of auto switch		When fingers return: Auto switch to turn ON (Light ON)	When gripping a workpiece: Auto switch to turn ON (Light ON)	When a workpiece is not held (Abnormal operation): Auto switch to turn ON (Light ON)
Detection combinations	One auto switch * One position, any of ①, ② and ③ can be detected.	●	●	●
	Two auto switches * Two positions of ①, ② and ③ can be detected.	Pattern A	●	—
		Pattern B	—	●
Pattern C	●	—	●	
How to determine auto switch installation position		Step 1) Fully close the fingers. 	Step 1) Position fingers for gripping a workpiece. 	Step 1) Fully open the fingers. 
At no pressure or low pressure, connect the auto switch to a power supply, and follow the directions.		Step 2) Insert the auto switch into the auto switch mounting groove from the direction of the arrow. 		
		Step 3) Slide the auto switch in the direction of the arrow until the indicator light illuminates.  Step 4) Slide the auto switch further in the direction of the arrow until the indicator light goes out.  Step 5) Slide the auto switch in the opposite direction and fasten it at a position 0.3 to 0.5 mm beyond the position where the indicator light illuminates. Position where light turns ON  Position to be secured 	Step 3) Slide the auto switch in the direction of the arrow until the indicator light illuminates and fasten it at a position 0.3 to 0.5 mm in the direction of the arrow beyond the position where the indicator light illuminates. Position where light turns ON  Position to be secured 	

- * It is recommended that gripping of a workpiece be performed close to the center of the finger stroke.
- * When holding a workpiece close at the end of opening/closing stroke of fingers, detecting performance of the combinations listed in the above table may be limited, depending on the hysteresis of an auto switch, etc.

Auto Switch Hysteresis

The auto switch hysteresis is shown in the table. Refer to the table as a guide when setting auto switch positions.

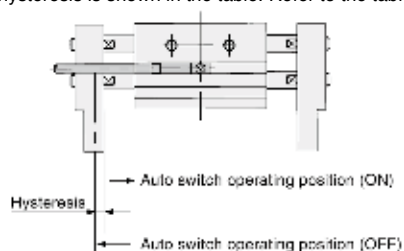

Auto switch model	[mm]	
	D-M9□(V)	D-M9□W(V)
MHL2-10D□Z	0.2	
MHL2-16D□Z	0.5	
MHL2-20D□Z	0.4	
MHL2-25D□Z	0.4	
MHL2-32D□Z	0.9	
MHL2-40D□Z	0.7	

MHL2 Series Prior to Use Auto Switch Connections and Examples

Sink Input Specifications

3-wire, NPN

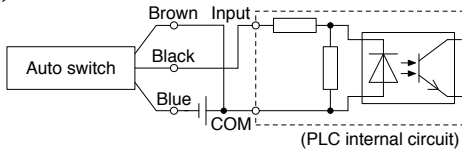

2-wire

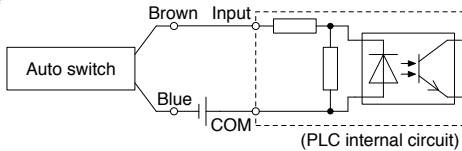

Source Input Specifications

3-wire, PNP

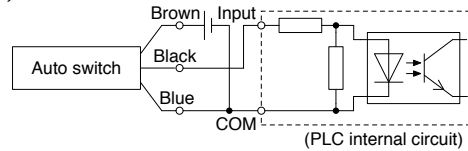

2-wire

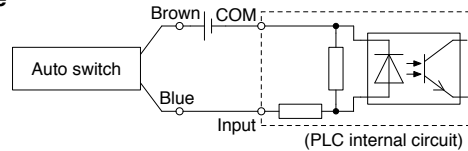

Connect according to the applicable PLC input specifications, as the connection method will vary depending on the PLC input specifications.

Examples of AND (Series) and OR (Parallel) Connections

* When using solid state auto switches, ensure the application is set up so the signals for the first 50 ms are invalid. Depending on the operating environment, the product may not operate properly.

3-wire AND connection for NPN output

(Using relays)

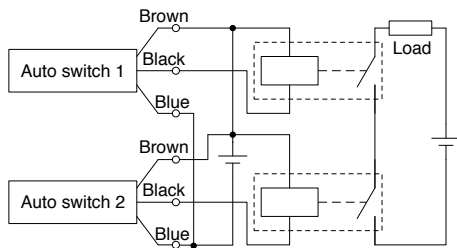

(Performed with auto switches only)

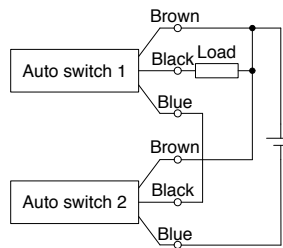

3-wire OR connection for NPN output

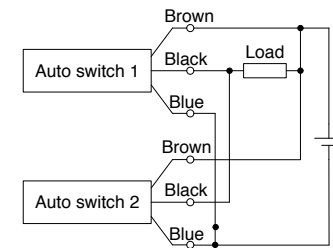

3-wire AND connection for PNP output

(Using relays)

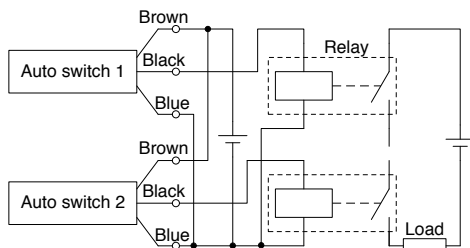

(Performed with auto switches only)

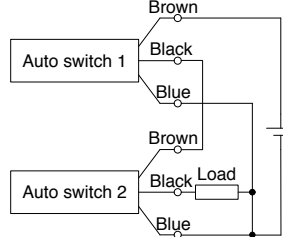

3-wire OR connection for PNP output

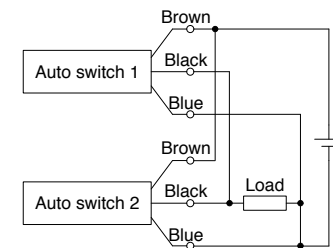

2-wire AND connection

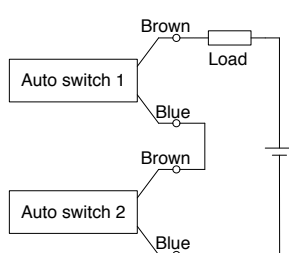

When two auto switches are connected in series, a load may malfunction because the load voltage will decline when in the ON state. The indicator lights will light up when both of the auto switches are in the ON state. Auto switches with a load voltage less than 20 V cannot be used.

$$\begin{aligned} \text{Load voltage at ON} &= \text{Power supply voltage} - \\ &\quad \text{Residual voltage} \times 2 \text{ pcs.} \\ &= 24 \text{ V} - 4 \text{ V} \times 2 \text{ pcs.} \\ &= 16 \text{ V} \end{aligned}$$

Example: Power supply is 24 VDC
Internal voltage drop in auto switch is 4 V.

2-wire OR connection

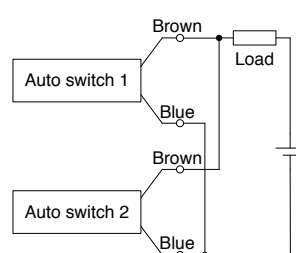

(Solid state)
When two auto switches are connected in parallel, malfunction may occur because the load voltage will increase when in the OFF state.

(Reed)
Because there is no current leakage, the load voltage will not increase when turned OFF. However, depending on the number of auto switches in the ON state, the indicator lights may sometimes grow dim or not light up, due to the dispersion and reduction of the current flowing to the auto switches.

$$\begin{aligned} \text{Load voltage at OFF} &= \text{Leakage current} \times 2 \text{ pcs.} \times \\ &\quad \text{Load impedance} \\ &= 1 \text{ mA} \times 2 \text{ pcs.} \times 3 \text{ k}\Omega \\ &= 6 \text{ V} \end{aligned}$$

Example: Load impedance is 3 kΩ.
Leakage current from auto switch is 1 mA.

Made to Order *MHL2 Series*

①-X4	Heat Resistant (-10 to 100°C)	Page 18
②-X5	Fluororubber Seal	Page 18
③-X28	With Bolt for Adjusting the Closing Width	Page 19
④-X50	Without Magnet	Page 19
⑤-X53	Ethylene Propylene Rubber Seal (EPDM)	Page 19
⑥-X63	Fluorine Grease	Page 20
⑦-X79	Grease for Food Processing Machines: Fluorine Grease	Page 20
⑧-X79A	Grease for Food Processing Machines: Aluminum Complex Soap Base Grease	Page 21
⑨-X85	Fine-particle Proof Specification	Page 21
⑩-X86□	With Heavy Duty Scraper + Stable Lubrication Function (Lube-retainer) (Seal Material: NBR, Fluororubber)	Page 23



1 Heat Resistant (-10 to 100°C)

Symbol

-X4

Seal material and grease have been changed so that the product can be used at temperatures between -10 up to 100°C.

How to Order

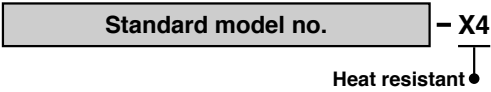

- * Magnet is built-in, but when using an auto switch, the acceptable temperature range becomes -10 to 60°C.
- * For lubrication, specialized grease GR-F is recommended.

Specifications

Ambient temperature range	-10°C to 100°C (No freezing)
Seal material	Fluororubber
Grease	Heat-resistant grease (GR-F)
Specifications/dimensions other than the above	Same as the standard type

Replacement Parts: Seal Kit

Seal kit part number
MHL□□-PS-X4

- * Enter the cylinder bore size into □□ of the seal kit part number. Refer to page 7 for the replacement parts.
- * The seal kit does not include a grease pack. Order it separately.
Grease pack part number: GR-F-005 (5 g)

**⚠ Warning
Precautions**

Be aware that smoking cigarettes after your hands have come into contact with the grease used for this product can create a gas that is hazardous to humans.

2 Fluororubber Seal

Symbol

-X5

How to Order

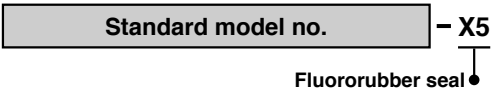

- * Please contact SMC, since the type of chemical and the operating temperature may not allow the use of this product.
- * Since the standard type magnet is built-in, please contact SMC for the product's adaptability to the operating environment.

Specifications

Seal material	Fluororubber
Specifications/dimensions other than the above	Same as the standard type

3 With Bolt for Adjusting the Closing Width

Symbol
-X28

Finger closing stroke can be fine-tuned by an adjustment bolt.

How to Order

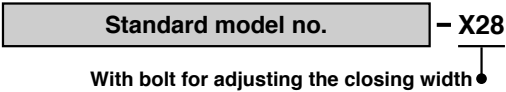

Specifications

Adjustment range/ Adjustment bolt position	Refer to the dimensions below.
Specifications other than the above	Same as the standard type
Dimensions	Refer to the dimensions below.

- * Please contact SMC for ø40.
- * The bumper at the end of the adjustment bolt is not heat resistant. Combination with high temperature type is only available with a metal stopper.

Dimensions (The dimensions other than specified below are the same as the standard type.)

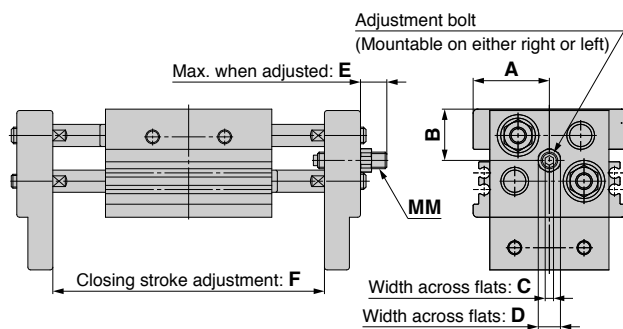

Model	A	B	C	D	E	F	MM
MHL2-10DZ-X28	22	15.5	2.5	7	4	2	M5 x 0.8
MHL2-10D1Z-X28					11	16	
MHL2-10D2Z-X28					11	16	
MHL2-16DZ-X28	27.5	18.5	3	8	9.5	9	M6 x 1
MHL2-16D1Z-X28					13.5	20	
MHL2-16D2Z-X28					13.5	20	
MHL2-20DZ-X28	32.5	21	4	12	7.5	7	M8 x 1
MHL2-20D1Z-X28					8.5	9	
MHL2-20D2Z-X28					8.5	9	
MHL2-25DZ-X28	38	26	5	14	7.5	7	M10 x 1
MHL2-25D1Z-X28				17	15	18	M10 x 1.5
MHL2-25D2Z-X28				15	18		
MHL2-32DZ-X28	41	32	6	19	32.5	51	M12 x 1.75
MHL2-32D1Z-X28					32.5		
MHL2-32D2Z-X28					32.5		

4 Without Magnet

Symbol
-X50

How to Order

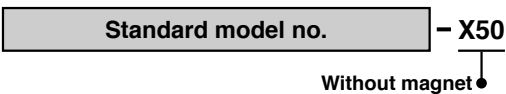

Specifications

Magnet	None
Specifications/dimensions other than the above	Same as the standard type

5 Ethylene Propylene Rubber Seal (EPDM)

Symbol
-X53

Seal material has been changed to ethylene propylene (EPDM), and grease to fluorine grease.

How to Order

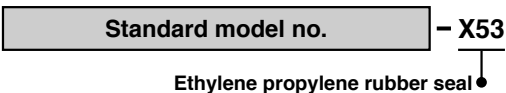

- * For lubrication, specialized grease GR-F is recommended.
Grease pack part number: GR-F-005 (5 g)

Specifications

Seal material	Ethylene propylene rubber (EPDM)
Grease	Fluorine grease (GR-F)
Specifications/dimensions other than the above	Same as the standard type

Warning Precautions

Be aware that smoking cigarettes after your hands have come into contact with the grease used for this product can create a gas that is hazardous to humans.

6 Fluorine Grease

Symbol
-X63

Standard model no. **- X63**
Fluorine grease

* For lubrication, specialized grease GR-F is recommended.
Grease pack part number: GR-F-005 (5 g)

Warning
Precautions

Be aware that smoking cigarettes after your hands have come into contact with the grease used for this product can create a gas that is hazardous to humans.

Specifications

Grease	Fluorine grease (GR-F)
Specifications/dimensions other than the above	Same as the standard type

7 Grease for Food Processing Machines: Fluorine Grease

Symbol
-X79

Use grease for food processing machines (NSF-H1 certified/fluorine grease).

How to Order

Standard model no. **- X79**
Grease for food processing machines:
Fluorine grease

* For lubrication, specialized grease GR-H is recommended.
Grease pack part number: GR-H-010 (10 g)

Warning
Precautions

Be aware that smoking cigarettes after your hands have come into contact with the grease used for this product can create a gas that is hazardous to humans.

Caution

Do not use air grippers in a food-related environment.

<Not installable>

Food zone Food may directly contact with air grippers, and is treated as food products.

<Installable>

Splash zone Food may directly contact with air grippers, but is not treated as food products.

Non-food zone Air grippers do not directly contact food.

Specifications

Grease	Grease for food processing machines (NSF-H1 certified)/Fluorine grease
Specifications/dimensions other than the above	Same as the standard type

* If the fluorine grease is not applicable to the working environment, use "X79A."

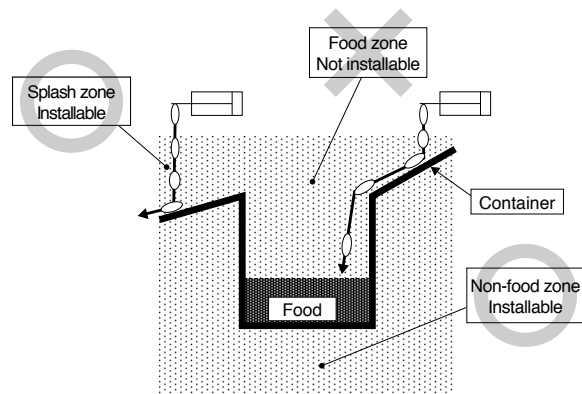

8 Grease for Food Processing Machines: Aluminum Complex Soap Base Grease

Symbol
-X79A

Use grease for food processing machines (NSF-H1 certified).

How to Order

Standard model no. **- X79A**

Grease for food processing machines:
Aluminum complex soap base grease

* For lubrication, specialized grease GR-R is recommended.
Grease pack part number: GR-R-010 (10 g)

Specifications

Grease	Grease for food processing machines (NSF-H1 certified)/Aluminum complex soap base grease
Specifications/dimensions other than the above	Same as the standard type

Caution

Do not use air grippers in a food-related environment.

<Not installable>

Food zone Food may directly contact with air grippers, and is treated as food products.

<Installable>

Splash zone Food may directly contact with air grippers, but is not treated as food products.

Non-food zone Air grippers do not directly contact food.

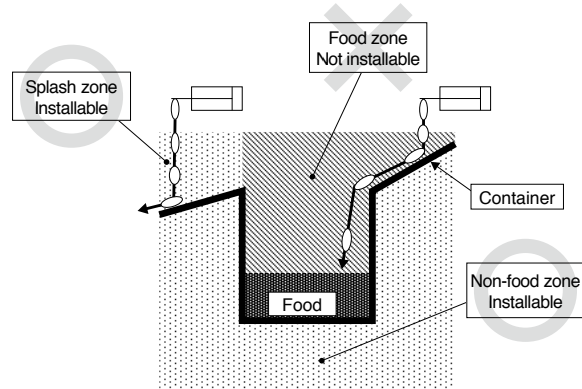

9 Fine-particle Proof Specification

Symbol
-X85

Applicable for environments with flying micro-powder (10 to 100 μm) such as ceramic powder, toner powder, paper powder, and metallic powder (excluding weld spatter)

A grease film is formed on the rod by the Lube-retainer which maintains lubrication for longer increasing gripper endurance.

How to Order

Standard model no. **- X85**

Fine-particle proof specification

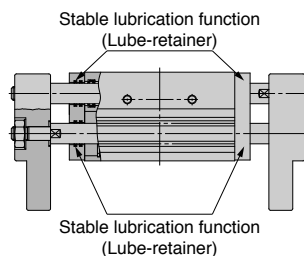

Specifications

Bore size [mm]	10	16	20	25	32	40
Dust prevention method	Stable lubrication function (Lube-retainer) type (8 locations)					
Operating pressure [MPa]	0.4 to 0.6		0.3 to 0.6			
Repeatability	±0.1					
Effective gripping force [N] ^{*1} at 0.5 MPa	14	45	74	131	228	396

*1 Gripping point distance: 40 mm

Specifications other than the above	Same as the standard type
Dimensions	Refer to the dimensions on page 23.

Gripping Point

- The workpiece gripping point distance should be within the gripping force ranges given for each pressure in the effective gripping force graphs on the next page.
- If operated with the workpiece gripping point beyond the indicated ranges, the load that will be applied to the fingers or the guide will become excessively unbalanced. As a result, the fingers could become loosened and adversely affect the service life of the unit.

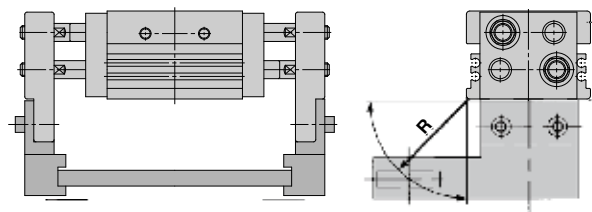

R: Gripping point distance [mm]

9 Fine-particle Proof Specification

Symbol
-X85

Effective Gripping Force

• **Indication of effective gripping force**

The gripping force shown in the tables represents the gripping force of one finger when all fingers and attachments are in contact with the workpiece.

F = One finger thrust

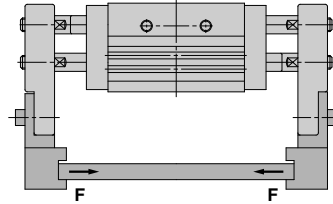

MHL2-10DZ-X85

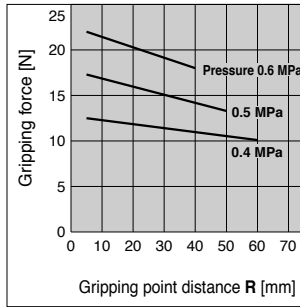

MHL2-10D¹/₂Z-X85

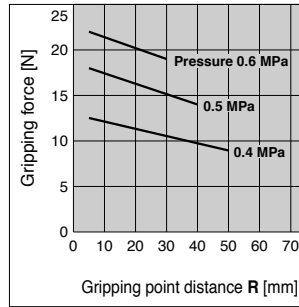

MHL2-16DZ-X85

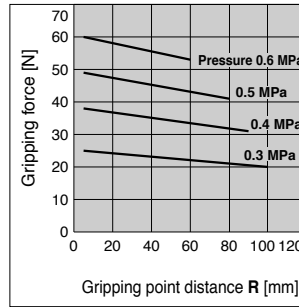

MHL2-16D¹/₂Z-X85

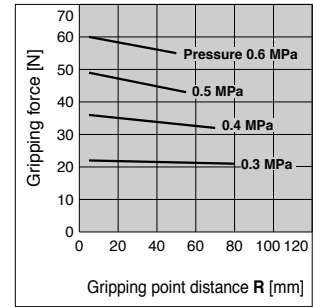

MHL2-20DZ-X85

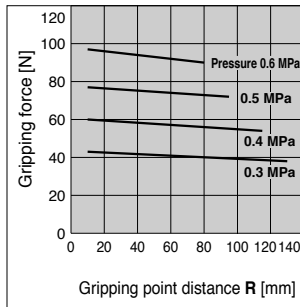

MHL2-20D¹/₂Z-X85

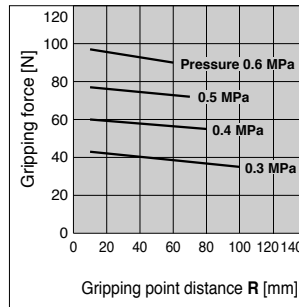

MHL2-25DZ-X85

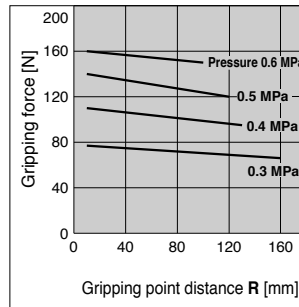

MHL2-25D¹/₂Z-X85

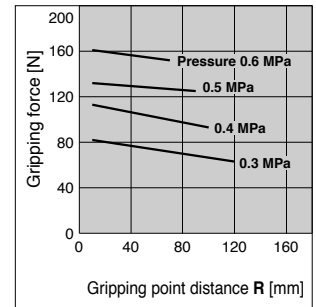

MHL2-32DZ-X85

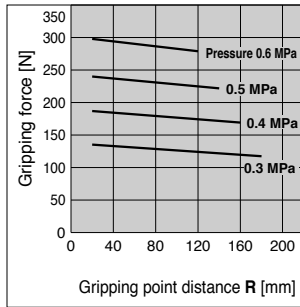

MHL2-32D¹/₂Z-X85

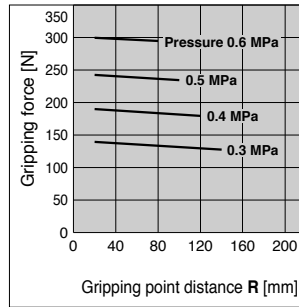

MHL2-40DZ-X85

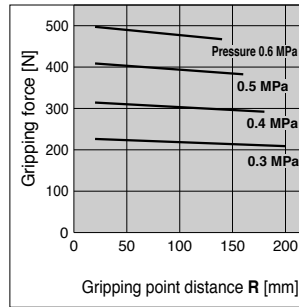

MHL2-40D¹/₂Z-X85

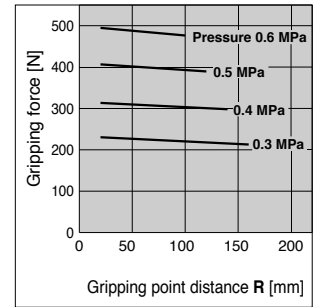

9 Fine-particle Proof Specification

Symbol
-X85

Dimensions (The dimensions other than specified below are the same as the standard type.)

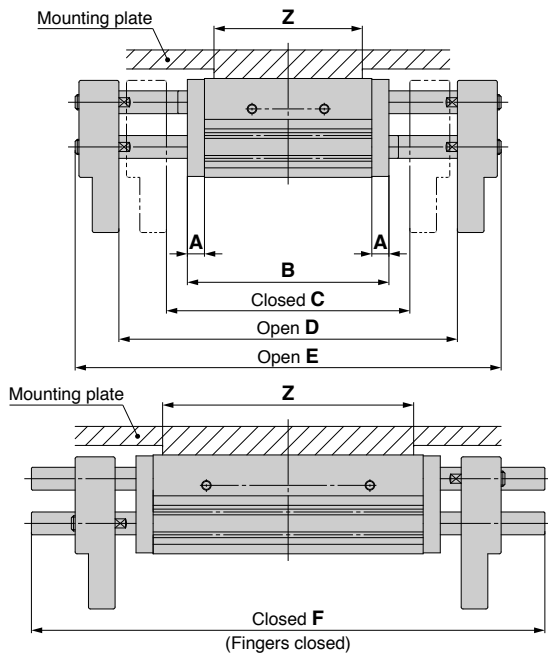

Model	A	B	C	D	E	F	Z	Weight [g]
MHL2-10DZ-X85	8	67	88	108	132	112	49	350
MHL2-10D1Z-X85	8	83	104	144	168	131	65	420
MHL2-10D2Z-X85	8	101	122	182	206	169	83	495
MHL2-16DZ-X85	9.5	79	96	126	156	126	58	650
MHL2-16D1Z-X85	9.5	109	126	186	216	179	88	840
MHL2-16D2Z-X85	9.5	129	146	226	256	219	108	965
MHL2-20DZ-X85	9	89	108	148	186	146	69	1115
MHL2-20D1Z-X85	9	131	150	230	268	221	111	1490
MHL2-20D2Z-X85	9	151	170	270	308	261	131	1675
MHL2-25DZ-X85	9	106	128	178	224	174	86	1815
MHL2-25D1Z-X85	9	160	182	282	328	270	140	2500
MHL2-25D2Z-X85	9	178	200	320	366	308	158	2730
MHL2-32DZ-X85	11.5	133	161	231	283	213	108	3255
MHL2-32D1Z-X85	11.5	181	209	329	381	311	156	4145
MHL2-32D2Z-X85	11.5	225	253	413	465	395	200	4960
MHL2-40DZ-X85	10	168	198	298	358	278	146	5685
MHL2-40D1Z-X85	10	226	256	416	476	396	204	7220
MHL2-40D2Z-X85	10	266	296	496	556	476	244	8270

* The customer's mounting plate should be attached with the Z-dimension.

10 With Heavy Duty Scraper + Stable Lubrication Function (Lube-retainer) (Seal Material: NBR, Fluororubber)

Symbol
-X86

- The cylinders are suitable for use in environments with significant amounts of dust with the heavy duty scraper on the wiper ring. In addition, the Lube-retainer creates a grease coating around the rod, which improves lubrication.
- Seal material can be NBR or fluororubber.

How to Order

Standard model no. **- X86**

With heavy duty scraper + Stable lubrication function (NBR seals)

Standard model no. **- X86A**

With heavy duty scraper + Stable lubrication function (Fluororubber seals)

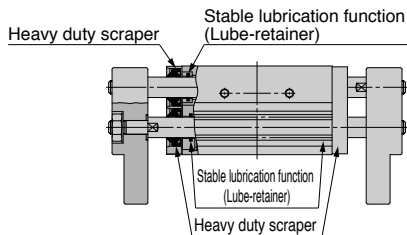

Specifications

Symbol	-X86			-X86A		
Bore size [mm]	25	32	40	25	32	40
Dust prevention method	Heavy duty scraper + Stable lubrication function (Lube-retainer) type (8 locations)					
Heavy duty scraper material	NBR			Fluororubber		
Operating pressure [MPa]	0.3 to 0.6					
Repeatability	±0.1					
Effective gripping force [N]*1 at 0.5 MPa	131	228	396	131	228	396

*1 Gripping point distance: 40 mm

* For water resistant type, please contact SMC local sales representative.

Specifications other than the above	Same as the standard type
Dimensions	Refer to the dimensions on page 24.

10 With Heavy Duty Scraper + Stable Lubrication Function (Lube-retainer) (Seal Material: NBR, Fluororubber)

Symbol

-X86

Effective Gripping Force

• **Indication of effective gripping force**

The gripping force shown in the tables represents the gripping force of one finger when all fingers and attachments are in contact with the workpiece.

F = One finger thrust

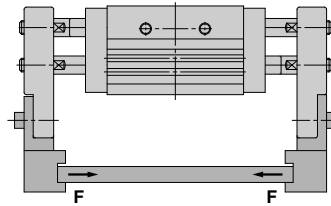

MHL2-25DZ-X86/X86A

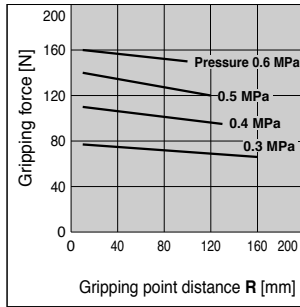

MHL2-25D $\frac{1}{2}$ Z-X86/X86A

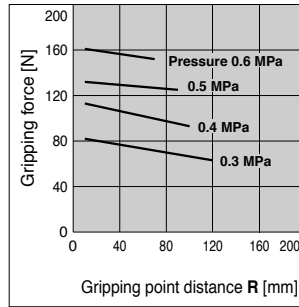

MHL2-32DZ-X86/X86A

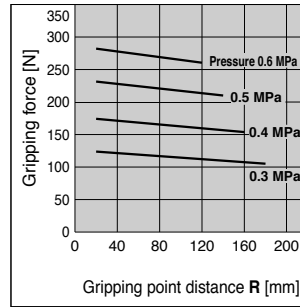

MHL2-32D $\frac{1}{2}$ Z-X86/X86A

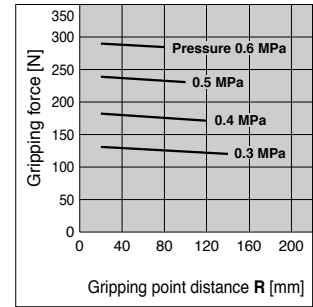

MHL2-40DZ-X86/X86A

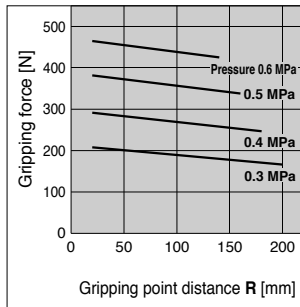

MHL2-40D $\frac{1}{2}$ Z-X86/X86A

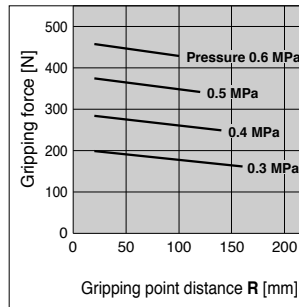

Dimensions (The dimensions other than specified below are the same as the standard type.)

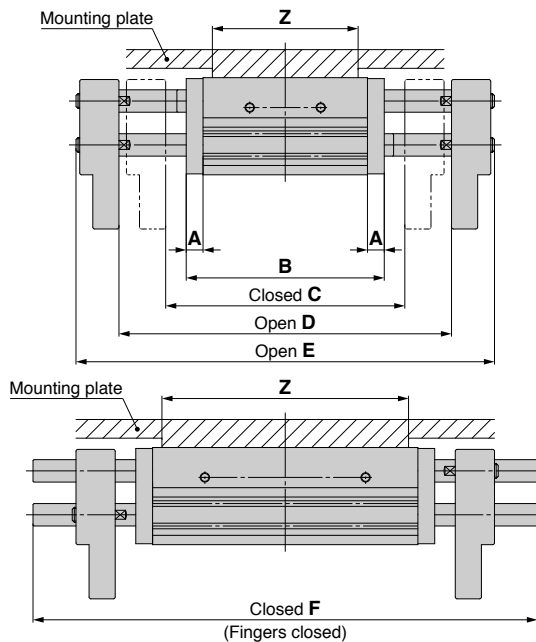

Model	A	B	C	D	E	F	Z	Weight [g]
MHL2-25DZ-X86(A)	9	106	128	178	224	174	86	1835
MHL2-25D1Z-X86(A)	9	160	182	282	328	270	140	2520
MHL2-25D2Z-X86(A)	9	178	200	320	366	308	158	2750
MHL2-32DZ-X86(A)	11.5	133	161	231	283	213	108	3250
MHL2-32D1Z-X86(A)	11.5	181	209	329	381	311	156	4150
MHL2-32D2Z-X86(A)	11.5	225	253	413	465	395	200	4960
MHL2-40DZ-X86(A)	10	168	198	298	358	278	146	5765
MHL2-40D1Z-X86(A)	10	226	256	416	476	396	204	7295
MHL2-40D2Z-X86(A)	10	266	296	496	556	476	244	8340

* The customer's mounting plate should be attached with the Z-dimension.



MHL2 Series Specific Product Precautions

Be sure to read this before handling the products. Refer to the back cover for safety instructions. For temperature control equipment precautions, refer to the “Handling Precautions for SMC Products” and the “Operation Manual” on SMC website.

Design

⚠ Warning

If a workpiece is hooked onto the attachment, make sure that excessive impact will not be created at the start and the end of the movement. Failure to observe this precaution may result in shifting or dropping the workpiece, which could be dangerous.

How to Mount Air Grippers

Possible to mount from 2 directions

Axial Mounting

• Body tapped

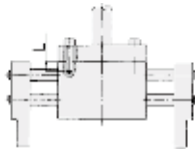

Model	Applicable bolt	Max. tightening torque [N·m]	Max. screw-in depth L [mm]
MHL2-10D□Z	M4 x 0.7	2.1	8
MHL2-16D□Z	M5 x 0.8	4.3	10
MHL2-20D□Z	M6 x 1	7.3	12
MHL2-25D□Z	M8 x 1.25	17.7	16
MHL2-32D□Z	M8 x 1.25	18	16
MHL2-40D□Z	M10 x 1.5	36	20

• Body through-hole



Model	Applicable bolt	Max. tightening torque [N·m]
MHL2-10D□Z	M4 x 0.7	2.1
MHL2-16D□Z	M5 x 0.8	4.3
MHL2-20D□Z	M6 x 1	7.3
MHL2-25D□Z	M8 x 1.25	17.7

Lateral Mounting

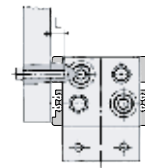

Model	Applicable bolt	Max. tightening torque [N·m]	Max. screw-in depth L [mm]
MHL2-10D□Z	M4 x 0.7	1.4	5
MHL2-16D□Z	M5 x 0.8	2.8	7
MHL2-20D□Z	M6 x 1	4.8	7
MHL2-25D□Z	M8 x 1.25	12.0	7
MHL2-32D□Z	M8 x 1.25	12.0	11
MHL2-40D□Z	M10 x 1.5	24.0	12

How to Mount Attachments to the Finger

1. Make sure that the piston rod is retracted so as to avoid twisting the piston rod when mounting an attachment to the finger.
2. Do not scratch or dent the sliding parts of the piston rod. Damage to the bearings or seals may cause air leaks or faulty operation.
3. Refer to the table on the right for the proper tightening torque on the bolt used for securing the attachment to the finger.

Model	Applicable bolt	Max. tightening torque [N·m]
MHL2-10D□Z	M4 x 0.7	1.4
MHL2-16D□Z	M5 x 0.8	2.8
MHL2-20D□Z	M6 x 1	4.8
MHL2-25D□Z	M8 x 1.25	12.0
MHL2-32D□Z	M10 x 1.5	24.0
MHL2-40D□Z	M12 x 1.75	42.2

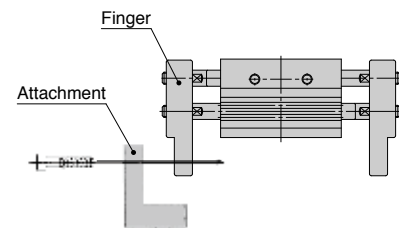

Safety Instructions

These safety instructions are intended to prevent hazardous situations and/or equipment damage. These instructions indicate the level of potential hazard with the labels of “Caution,” “Warning” or “Danger.” They are all important notes for safety and must be followed in addition to International Standards (ISO/IEC)*1), and other safety regulations.

 **Caution:** Caution indicates a hazard with a low level of risk which, if not avoided, could result in minor or moderate injury.

 **Warning:** Warning indicates a hazard with a medium level of risk which, if not avoided, could result in death or serious injury.

 **Danger:** Danger indicates a hazard with a high level of risk which, if not avoided, will result in death or serious injury.

*1) ISO 4414: Pneumatic fluid power – General rules relating to systems.
 ISO 4413: Hydraulic fluid power – General rules relating to systems.
 IEC 60204-1: Safety of machinery – Electrical equipment of machines.
 (Part 1: General requirements)
 ISO 10218-1: Manipulating industrial robots – Safety.
 etc.

Warning

1. The compatibility of the product is the responsibility of the person who designs the equipment or decides its specifications.

Since the product specified here is used under various operating conditions, its compatibility with specific equipment must be decided by the person who designs the equipment or decides its specifications based on necessary analysis and test results. The expected performance and safety assurance of the equipment will be the responsibility of the person who has determined its compatibility with the product. This person should also continuously review all specifications of the product referring to its latest catalog information, with a view to giving due consideration to any possibility of equipment failure when configuring the equipment.

2. Only personnel with appropriate training should operate machinery and equipment.

The product specified here may become unsafe if handled incorrectly. The assembly, operation and maintenance of machines or equipment including our products must be performed by an operator who is appropriately trained and experienced.

3. Do not service or attempt to remove product and machinery/equipment until safety is confirmed.

1. The inspection and maintenance of machinery/equipment should only be performed after measures to prevent falling or runaway of the driven objects have been confirmed.
2. When the product is to be removed, confirm that the safety measures as mentioned above are implemented and the power from any appropriate source is cut, and read and understand the specific product precautions of all relevant products carefully.
3. Before machinery/equipment is restarted, take measures to prevent unexpected operation and malfunction.

4. Contact SMC beforehand and take special consideration of safety measures if the product is to be used in any of the following conditions.

1. Conditions and environments outside of the given specifications, or use outdoors or in a place exposed to direct sunlight.
2. Installation on equipment in conjunction with atomic energy, railways, air navigation, space, shipping, vehicles, military, medical treatment, combustion and recreation, or equipment in contact with food and beverages, emergency stop circuits, clutch and brake circuits in press applications, safety equipment or other applications unsuitable for the standard specifications described in the product catalog.
3. An application which could have negative effects on people, property, or animals requiring special safety analysis.
4. Use in an interlock circuit, which requires the provision of double interlock for possible failure by using a mechanical protective function, and periodical checks to confirm proper operation.

Caution

1. The product is provided for use in manufacturing industries.

The product herein described is basically provided for peaceful use in manufacturing industries.
 If considering using the product in other industries, consult SMC beforehand and exchange specifications or a contract if necessary.
 If anything is unclear, contact your nearest sales branch.

Limited warranty and Disclaimer/ Compliance Requirements

The product used is subject to the following “Limited warranty and Disclaimer” and “Compliance Requirements”.

Read and accept them before using the product.

Limited warranty and Disclaimer

1. The warranty period of the product is 1 year in service or 1.5 years after the product is delivered, whichever is first.*2)
2. For any failure or damage reported within the warranty period which is clearly our responsibility, a replacement product or necessary parts will be provided. This limited warranty applies only to our product independently, and not to any other damage incurred due to the failure of the product.
3. Prior to using SMC products, please read and understand the warranty terms and disclaimers noted in the specified catalog for the particular products.

*2) Vacuum pads are excluded from this 1 year warranty.

A vacuum pad is a consumable part, so it is warranted for a year after it is delivered. Also, even within the warranty period, the wear of a product due to the use of the vacuum pad or failure due to the deterioration of rubber material are not covered by the limited warranty.

Compliance Requirements

1. The use of SMC products with production equipment for the manufacture of weapons of mass destruction (WMD) or any other weapon is strictly prohibited.
2. The exports of SMC products or technology from one country to another are governed by the relevant security laws and regulations of the countries involved in the transaction. Prior to the shipment of a SMC product to another country, assure that all local rules governing that export are known and followed.

Caution

SMC products are not intended for use as instruments for legal metrology.

Measurement instruments that SMC manufactures or sells have not been qualified by type approval tests relevant to the metrology (measurement) laws of each country. Therefore, SMC products cannot be used for business or certification ordained by the metrology (measurement) laws of each country.

 **Safety Instructions** Be sure to read the “Handling Precautions for SMC Products” (M-E03-3) and “Operation Manual” before use.

UNIT CONVERSIONS

	unit	conversion	result		unit	conversion	result
length	m	x 3.28	psi	pressure	MPa	x 145	psi
	mm	x 0.04	psi		kPa	÷ 6.895	psi
mass	g	x 0.04	°F	temperature	°C	x1.8 then add 32	°F
volume	cm ³	÷ 16.387	ft-lb	torque	N·m	x 0.738	ft-lb
	L	x 61.024	lbf	force	N	÷ 4.448	lbf
speed	mm/s	÷ 25.4	cfm	flow	L/min	÷ 28.317	cfm

Global Manufacturing, Distribution and Service Network

Worldwide Subsidiaries

EUROPE

AUSTRIA
SMC Pneumatik GmbH (Austria)

BELGIUM
SMC Pneumatics N.V./S.A.

BULGARIA
SMC Industrial Automation Bulgaria EOOD

CROATIA
SMC Industrijska Automatika d.o.o.

CZECH REPUBLIC
SMC Industrial Automation CZ s.r.o.

DENMARK
SMC Pneumatik A/S

ESTONIA
SMC Pneumatics Estonia

FINLAND
SMC Pneumatics Finland OY

FRANCE
SMC Pneumatique S.A.

GERMANY
SMC Pneumatik GmbH

GREECE
SMC Hellas EPE

HUNGARY
SMC Hungary Ipari Automatizálási Kft.

IRELAND
SMC Pneumatics (Ireland) Ltd.

ITALY
SMC Italia S.p.A.

KAZAKHSTAN
LLP "SMC Kazakhstan"

LATVIA
SMC Pneumatics Latvia SIA

LITHUANIA
UAB "SMC Pneumatics"

NETHERLANDS
SMC Pneumatics B.V.

NORWAY
SMC Pneumatics Norway AS

POLAND
SMC Industrial Automation Polska Sp. z o.o.

ROMANIA
SMC Romania S.r.l.

RUSSIA
SMC Pneumatik LLC.

SLOVAKIA
SMC Priemyselná Automatizácia, Spol s.r.o.

SLOVENIA
SMC Industrijska Avtomatika d.o.o.

SPAIN / PORTUGAL
SMC España, S.A.

SWEDEN
SMC Pneumatics Sweden AB

SWITZERLAND
SMC Pneumatik AG

TURKEY
SMC Pnömatik Sanayi Ticaret ve Servis A.Ş.

UK
SMC Pneumatics (U.K.) Ltd.

ASIA / OCEANIA

AUSTRALIA
SMC Pneumatics (Australia) Pty. Ltd.

CHINA
SMC (China) Co., Ltd.
SMC Pneumatics (Guangzhou) Ltd.

HONG KONG
SMC Pneumatics (Hong kong) Ltd.

INDIA
SMC Pneumatics (India) Pvt. Ltd.

INDONESIA
PT. SMC Pneumatics Indonesia

JAPAN
SMC Corporation

MALAYSIA
SMC Pneumatics (S.E.A.) Sdn. Bhd.

NEW ZEALAND
SMC Pneumatics (N.Z.) Ltd.

PHILIPPINES
Shoketsu SMC Corporation

SINGAPORE
SMC Pneumatics (S.E.A.) Pte. Ltd.

SOUTH KOREA
SMC Pneumatics Korea Co., Ltd.

TAIWAN
SMC Pneumatics (Taiwan) Co., Ltd.

THAILAND
SMC (Thailand) Ltd.

UNITED ARAB EMIRATES
SMC Pneumatics Middle East FZE

VIETNAM
SMC Pneumatics (VN) Co., Ltd

AFRICA

SOUTH AFRICA
SMC Pneumatics (South Africa) Pty Ltd

NORTH, CENTRAL & SOUTH AMERICA

ARGENTINA
SMC Argentina S.A.

BOLIVIA
SMC Pneumatics Bolivia S.R.L.

BRAZIL
SMC Pneumáticos do Brasil Ltda.

CANADA
SMC Pneumatics (Canada) Ltd.

CHILE
SMC Pneumatics (Chile) S.A.

COLOMBIA
SMC Colombia Sucursal de SMC Chile, S.A.

MEXICO
SMC Corporation (Mexico) S.A. de C.V.

PERU
SMC Corporation Peru S.A.C.

USA
SMC Corporation of America

VENEZUELA
SMC Neumatica Venezuela S.A.

U.S. & Canadian Sales Offices

WEST

Austin
Dallas
Los Angeles
Phoenix
Portland
San Jose

CENTRAL

Chicago
Cincinnati
Cleveland
Detroit
Des Moines
Grand Rapids
Indianapolis
Kansas City
Milwaukee
Minneapolis
St. Louis



EAST

Albany
Atlanta
Birmingham
Boston
Charlotte
Knoxville
Nashville
New Jersey
Rochester
Tampa

CANADA

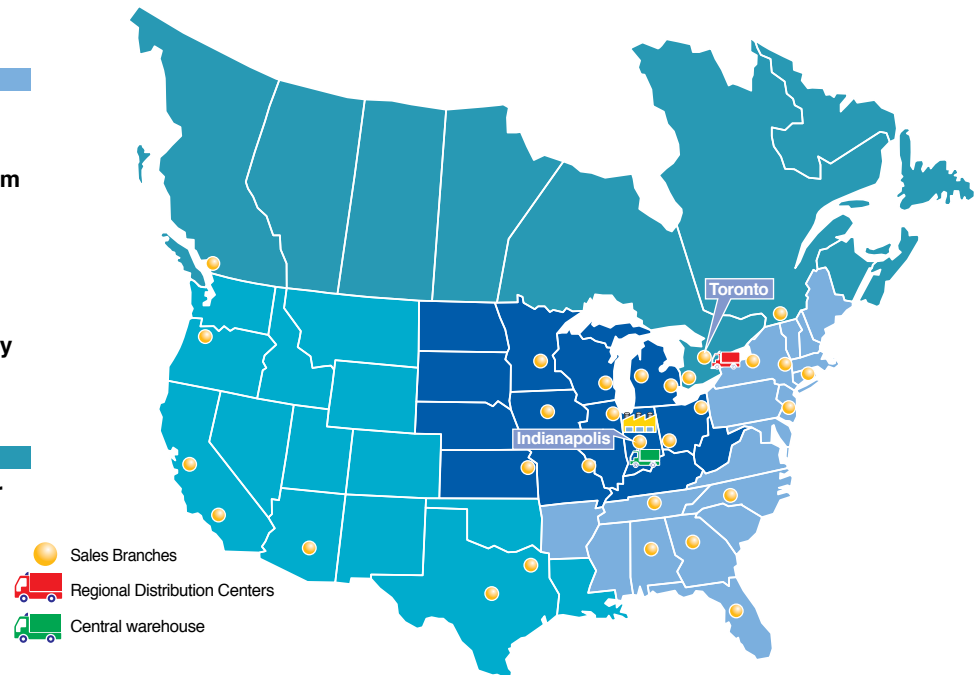
Vancouver
Toronto
Windsor
Montreal



● Sales Branches
 Regional Distribution Centers
 Central warehouse

