

Now with compact / energy saving / high-dispense-volume **Body material** polypropylene (PP)!

Compact

Height **185 mm** X Width **134 mm** X Depth **202 mm**

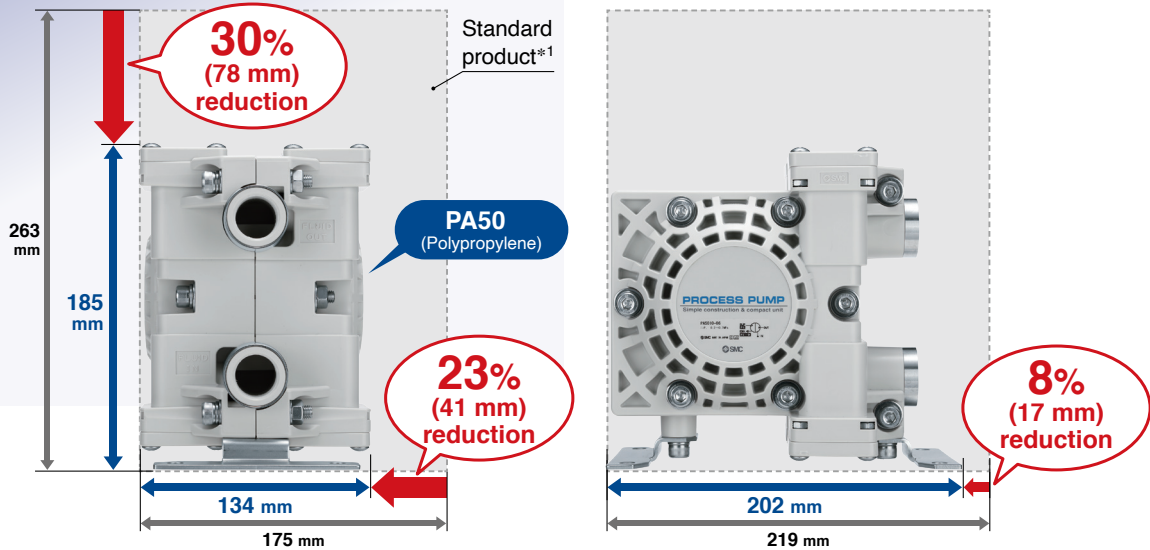

Volume 50% reduction
(10000 cm³ a 5000 cm³)

Installation area 30% reduction
(383 cm² a 270 cm²)

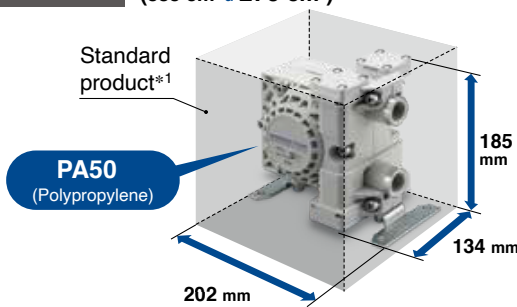

Discharge rate [L/min]

Manufacturer	Port size	Discharge rate [L/min]
SMC	3/4"	63
	1/2"	53
Standard product*1	1/2"	50

26% increase (53 vs 50)

6% increase (63 vs 50)

Air consumption [L/min (ANR)]

Discharge rate: 45 L/min

Manufacturer	Port size	Air consumption [L/min (ANR)]
SMC	3/4"	170
	1/2"	230
Standard product*1	1/2"	360

53% reduction (170 vs 360)

36% reduction (230 vs 360)

*1 Standard port size of 1/2", the average across three major domestic and overseas companies

Variations

New

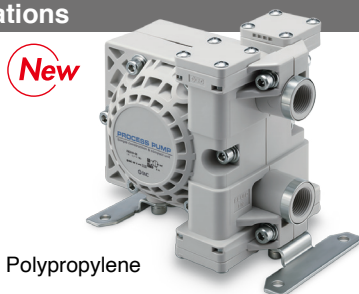

Fluid contact body material: Selectable from PP (polypropylene), aluminum or stainless steel

Body material

Body material	Port size	Discharge rate [L/min]	Diaphragm material
New Polypropylene (PP)	1/2"	5 to 53	PTFE
	3/4"	5 to 63	
Aluminum (ADC12)	1/2"	5 to 50	PTFE
	3/4"	5 to 60	NBR
Stainless steel (SCS14)	1/2"	5 to 50	PTFE
	3/4"	5 to 60	NBR

Fluid contact materials: aluminum is suitable for oils, stainless steel is suitable for solvents and industrial water, and PP is suitable for water, acids and alkali fluids.

Automatically operated type and air operated type are available.

Automatically Operated Type

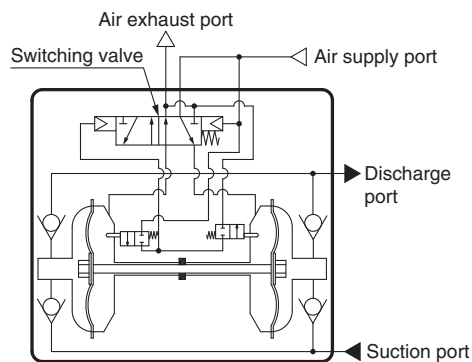

Compatible with a wide variety of fluids

Body wetted areas	Port size	Discharge rate [L/min]
Aluminum/Stainless steel	1/2"	5 to 50
	3/4"	5 to 60
Polypropylene	1/2"	5 to 53
	3/4"	5 to 63

Air Operated Type

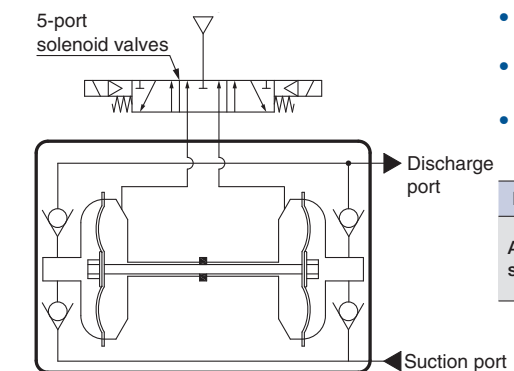



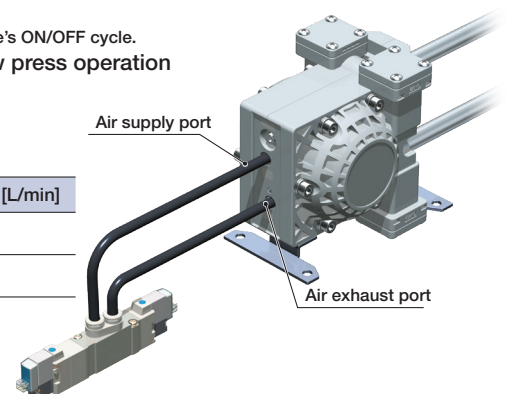

Control with external switching valve makes constant cycling possible.

- Easily control the discharge rate
Easily adjust the flow with the external solenoid valve's ON/OFF cycle.
- Easy to operate, even for minute flow, low press operation or operation involving air
- Can be used for operation with repetitive stopping

Body wetted areas	Port size	Discharge rate [L/min]
Aluminum/Stainless steel/Polypropylene	1/2"	1 to 45
	3/4"	1 to 50



Lightweight

			
	<p>Material: Polypropylene (PP)</p> <p>Weight [kg]: 3.0</p>	<p>Material: Aluminum (ADC12)</p> <p>Weight [kg]: 3.5</p>	<p>Material: Stainless steel (SCS14)</p> <p>Weight [kg]: 6.5</p>

High abrasion resistance and low particle generation

No sliding parts in wetted areas

Self-priming makes priming unnecessary

Exhausts the air inside the suction pipe to suck up liquid

Interchangeability maintained

The mounting pitches for aluminum models (PA51(13)13) and stainless steel models (PA52(13)13) are the same.

Without piping

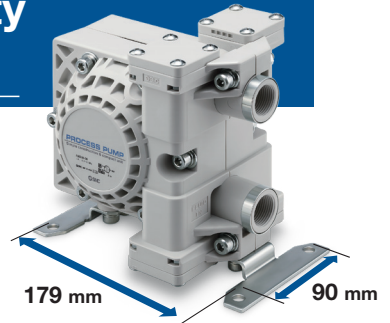

Application Examples

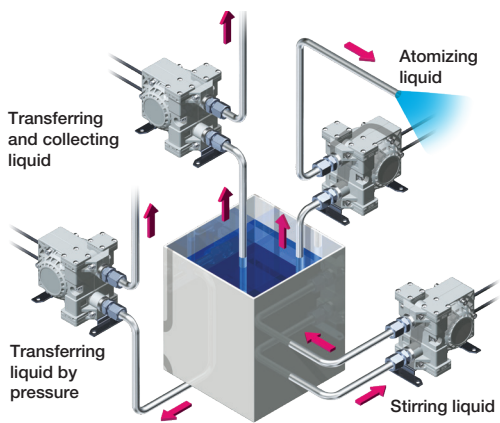

Car washing machine
Detergents transfer



Printing machines
Head cleaning liquid transfer

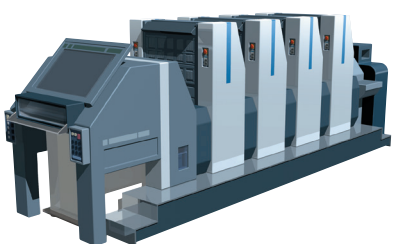

Machine tools
Coolant liquid collection

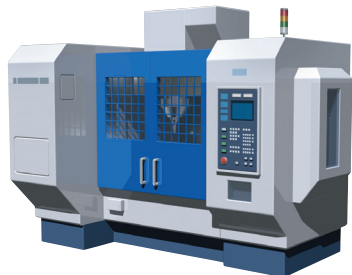

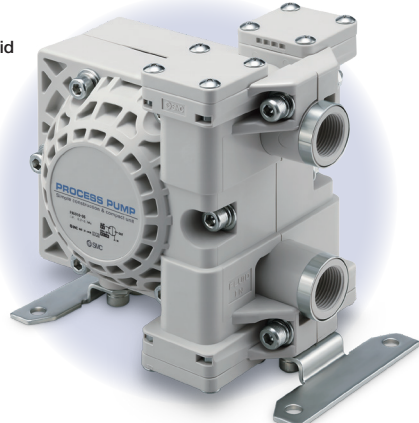

CONTENTS

Process Pump Automatically Operated Type/Air Operated Type

Internal Switching Type

External Switching Type

PA5000 Series



How to Order	p. 4
Specifications	p. 5
Performance Curve: Automatically Operated Type	p. 6
Performance Curve: Air Operated Type	p. 8
Working Principle	p. 9
Piping and Operation: Automatically Operated Type	p. 10
Piping and Operation: Air Operated Type	p. 11
Dimensions	p. 12
Made to Order Specifications	
1. Products Complying with ATEX	p. 14
2. With Air Operated Reset Port	p. 15
3. With Operating Cycle Counting Port	p. 16
Applicable Fluids	p. 17
Specific Product Precautions	p. 18

UNIT CONVERSIONS

	unit	conversion	result		unit	conversion	result
length	m	x 3.28	ft	pressure	MPa	x 145	psi
	mm	x 0.04	in		kPa	÷ 6.895	psi
mass	g	x 0.04	oz	temperature	°C	x1.8 then add 32	°F
volume	cm ³	÷ 16.387	in ³	torque	N·m	x 0.738	ft·lb
	L	x 61.024	in ³	force	N	÷ 4.448	lbf
speed	mm/s	÷ 25.4	in/s	flow	L/min	÷ 28.317	cfm

Process Pump

Automatically Operated Type (Internal Switching Type)

Air Operated Type (External Switching Type)

PA5000 Series



How to Order



PA 5 **1** **1** **0** - **04** -

Fluid contact body material

Symbol	Fluid contact body material
1	ADC12 (Aluminum)
2	SCS14 (Stainless steel)
0	PP (Polypropylene)

Option

Symbol	Option	Applicable actuation	
		Automatically operated	Air operated
Nil	Body only	●	●
N	With silencer*1	●	—

*1 For AIR EXH: AN20-□02
(For thread types, leave the □ box blank or enter N.)

Actuation

Symbol	Actuation
0	Automatically operated
3	Air operated

Port size

Symbol	Port size
04	1/2"
06	3/4"

Thread type

Symbol	Type	Applicable fluid contact body material		
		ADC12 (Aluminum)	SCS14 (Stainless steel)	PP (Polypropylene)
Nil	Rc	●	●	●
N	NPT	●	●	●
F	G	●	●	●
T	NPTF	●	●	—

Diaphragm material

Symbol	Actuation Body material Diaphragm material	Automatically operated			Air operated		
		ADC12 (Aluminum)	SCS14 (Stainless steel)	PP (Polypropylene)	ADC12 (Aluminum)	SCS14 (Stainless steel)	PP (Polypropylene)
1	PTFE	●	●	●	●	●	●
2	NBR	●	●	—	—	—	—

Symbol

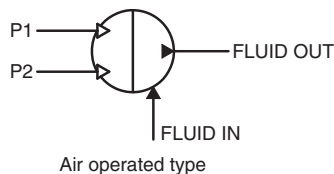
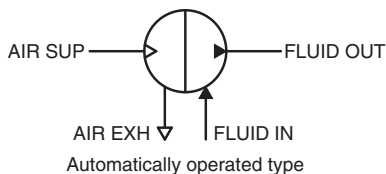

Made to Order specifications
(For details, refer to pages 14 to 16.)

Products complying with ATEX
With air operated reset port*1
With operating cycle counting port*1

*1 For automatically operated type only

PA5000 Series

Specifications

- * Each of the values is for normal temperatures and when the transferred fluid is fresh water.
- * Refer to page 9 for maintenance parts.

Automatically Operated Type

Model		PA5110-□04	PA5110-□06	PA5120-□04	PA5120-□06	PA5210-□04	PA5210-□06	PA5220-□04	PA5220-□06	PA5010-□04	PA5010-□06
Actuation		Automatically operated									
Port size	Main fluid suction discharge port	Rc, NPT, G, NPTF Female thread								Rc, NPT, G Female thread	
	Pilot air supply/exhaust port	1/2"	3/4"	1/2"	3/4"	1/2"	3/4"	1/2"	3/4"	1/2"	3/4"
Material	Body wetted areas	ADC12				SCS14				PP	
	Diaphragm	PTFE		NBR		PTFE		NBR		PTFE	
	Check valve	PTFE, PFA									
	Wetted part seal material	PTFE									
Fluid		Refer to the applicable fluids on page 17.									
Discharge rate		5 to 50 L/min	5 to 60 L/min	5 to 50 L/min	5 to 60 L/min	5 to 50 L/min	5 to 60 L/min	5 to 50 L/min	5 to 60 L/min	5 to 53 L/min	5 to 63 L/min
Average discharge pressure		0 to 0.6 MPa									
Pilot air pressure		0.2 to 0.7 MPa									
Air consumption		Refer to the flow rate characteristics on page 6.									
Suction lifting range*1	Dry	Up to 2 m (when the pump is dry)									
	Wet	Up to 6 m (when the pump is primed)									
Noise		78 dB (A) or less (Option: with silencer, AN20)									
Withstand pressure		1.05 MPa									
Diaphragm life*4		50 million times									
Operating fluid temperature		0 to 60°C (No freezing)									
Ambient temperature		0 to 60°C (No freezing)									
Maximum viscosity		5000 mPa·s									
Recommended operating cycle		-									
Pilot air solenoid valve recommended Cv factor*3		-									
Weight		3.5 kg				6.5 kg				3.0 kg	
Mounting orientation		Horizontal (with mounting foot at bottom)									
Packaging		General environment									

Air Operated Type

Model		PA5113-□04	PA5113-□06	PA5213-□04	PA5213-□06	PA5013-□04	PA5013-□06
Actuation		Air operated					
Port size	Main fluid suction discharge port	Rc, NPT, G, NPTF Female thread				Rc, NPT, G Female thread	
	Pilot air supply/exhaust port	1/2"	3/4"	1/2"	3/4"	1/2"	3/4"
Material	Body wetted areas	ADC12		SCS14		PP	
	Diaphragm	PTFE					
	Check valve	PTFE, PFA				PTFE, PP, PFA	
	Wetted part seal material	PTFE				FFKM	
Fluid		Refer to the applicable fluids on page 17.					
Discharge rate		1 to 45 L/min	1 to 50 L/min	1 to 45 L/min	1 to 50 L/min	1 to 45 L/min	1 to 50 L/min
Average discharge pressure		0 to 0.4 MPa					
Pilot air pressure		0.1 to 0.5 MPa					
Air consumption		Refer to the air consumption graph on page 8.					
Suction lifting range*1	Dry	Up to 0.5 m (when the pump is dry)					
	Wet	Up to 6 m (when the pump is primed)					
Noise		72 dB (A) or less (excluding the noise from the quick exhaust and solenoid valve)					
Withstand pressure		0.75 MPa					
Diaphragm life*4		50 million times					
Operating fluid temperature		0 to 60°C (No freezing)					
Ambient temperature		0 to 60°C (No freezing)					
Maximum viscosity		5000 mPa·s					
Recommended operating cycle		1 to 7 Hz (0.2 to 1 Hz also possible depending on conditions)*2					
Pilot air solenoid valve recommended Cv factor*3		0.45					
Weight		3.5 kg		6.5 kg		3.0 kg	
Mounting orientation		Horizontal (with mounting foot at bottom)					
Packaging		General environment					

*1 With cycles at 2 Hz or more

*2 After initial suction of liquid operating at 1 to 7 Hz, it can be used with operation at lower cycles.

Since a large quantity of liquid will be pumped out, use a suitable throttle on the discharge port if problems occur.

*3 With a low number of operating cycles, even a valve with a small Cv factor can be operated.

*4 These are reference values for room temperature and fresh water. These are not guaranteed. For details, refer to page 20.

Performance Curve: Automatically Operated Type

PA5₂¹□0-□04 Flow Rate Characteristics

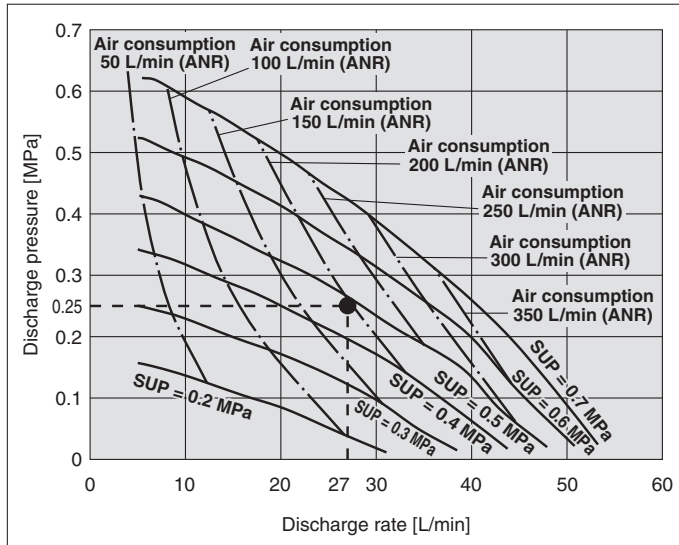

PA5₂¹□0-□06 Flow Rate Characteristics

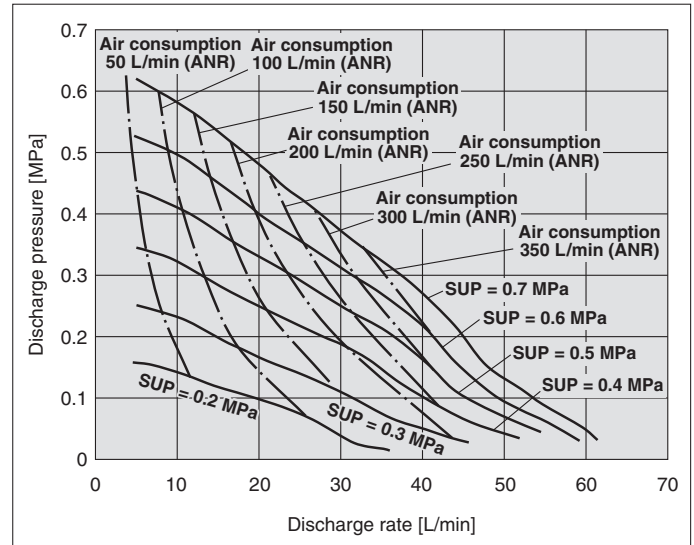

PA5010-13□04 Flow Rate Characteristics

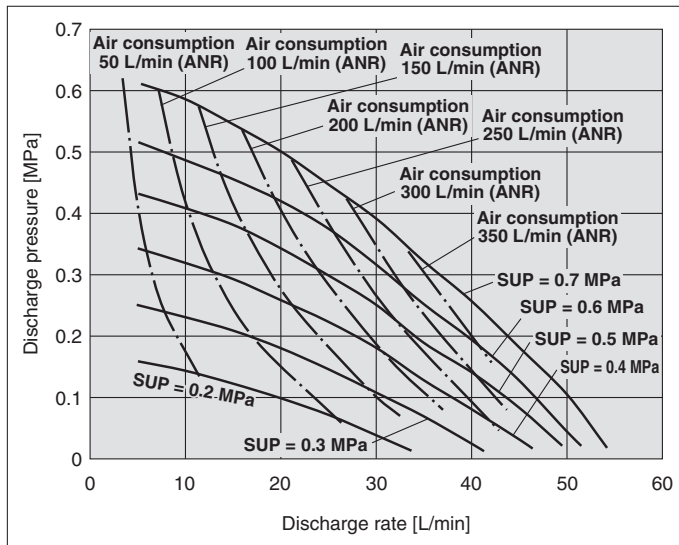

PA5010-□06 Flow Rate Characteristics

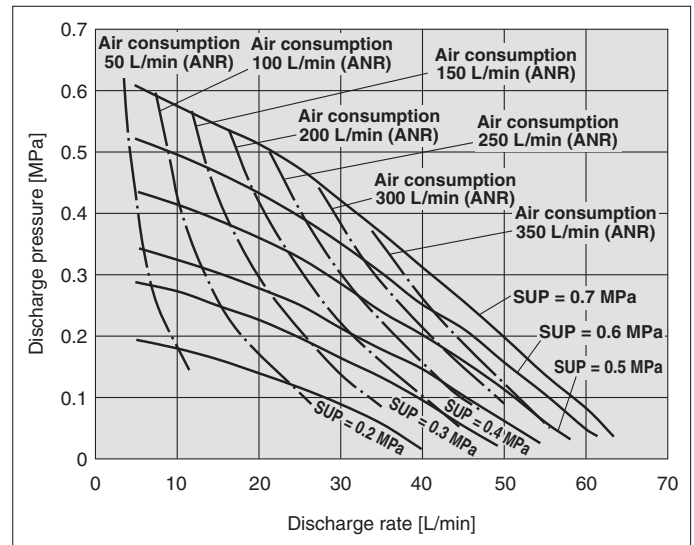

Selection from Flow Rate Characteristic Graph (PA5□□0)

Required specifications example:

Find the pilot air pressure and pilot air consumption for a discharge rate of 27 L/min and a discharge pressure of 0.25 MPa.

<The transferred fluid is fresh water (viscosity 1 mPa·s, specific gravity 1.0).>

* If the total lifting height is required instead of the discharge pressure, a discharge pressure of 0.1 MPa corresponds to a total lift of 10 m.

Selection procedures:

1. First, mark the intersection point for a discharge rate of 27 L/min and a discharge pressure of 0.25 MPa.
2. Find the pilot air pressure for the marked point. In this case, the point is between the discharge curves (solid lines) for SUP = 0.4 MPa and SUP = 0.5 MPa, and based on the proportional relationship to these lines, the pilot air pressure for this point is approx. 0.49 MPa.
3. Next, find the air consumption rate. The point is between the air consumption curves of 150 L/min (ANR) and 200 L/min (ANR). Based on its proportional relationship, the air consumption at this point is approx. 195 L/min (ANR).

⚠ Caution

1. These flow rate characteristics are for fresh water (viscosity 1 mPa·s, specific gravity 1.0).
2. The discharge rate differs greatly depending on properties (viscosity, specific gravity) of the fluid being transferred and operating conditions (lifting range, transfer distance), etc.
3. Use 0.75 kW per 100 L/min of air consumption as a guide for the relationship of the air consumption to the compressor.

PA5000 Series

Performance Curve: Automatically Operated Type

Viscosity Characteristics

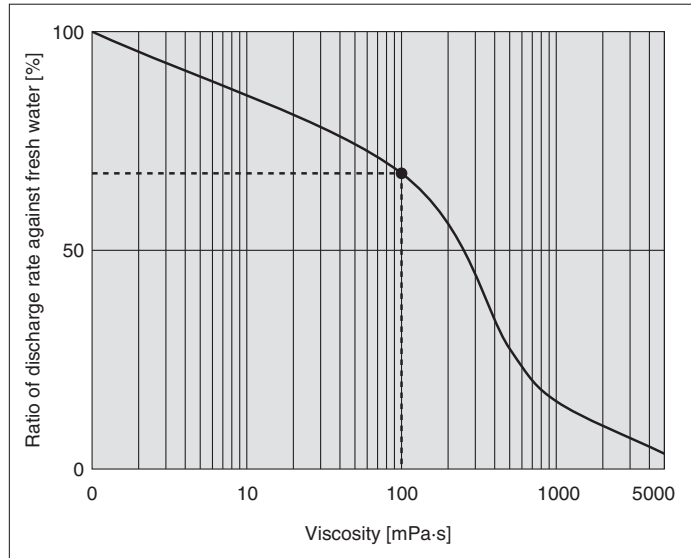

Selection from Viscosity Characteristic Graph

Required specifications example:

Find the pilot air pressure and pilot air consumption for a discharge rate of 12 L/min, discharge pressure of 0.25 MPa, and a viscosity of 100 mPa·s.

Selection procedures:

1. First, find the ratio of the discharge rate for fresh water when viscosity is 100 mPa·s from the graph above. It is determined to be 68%.
2. Next, in the required specification example, the viscosity is 100 mPa·s and the discharge rate is 12 L/min. Since this is equivalent to 68% of the discharge rate for fresh water, $12 \text{ L/min} \div 0.68 = 17.6 \text{ L/min}$, indicating that a discharge rate of 17.6 L/min is required for fresh water.
3. Finally, find the pilot air pressure and pilot air consumption based on selection from the flow characteristic graphs.

⚠ Caution

Viscosities up to 5000 mPa·s can be used.

The following equation shows the relationship between the kinematic viscosity and the dynamic viscosity.

$$\text{Kinematic viscosity } n \text{ [m}^2\text{/s]} = \frac{\text{Viscosity } m \text{ [Pa}\cdot\text{s}]}{\text{Density } r \text{ [kg/m}^3\text{]}}$$

The commonly used unit system is

$$\text{Kinematic viscosity } n \text{ [cSt]} = \frac{\text{Viscosity } m \text{ [mPa}\cdot\text{s}]}{\text{Density } r \text{ [g/cm}^3\text{]}}$$

In addition, $1 \text{ [mPa}\cdot\text{s]} = 1 \text{ [cP]}$.

Performance Curve: Air Operated Type

PA5⁰₂13-□04 Flow Rate Characteristics

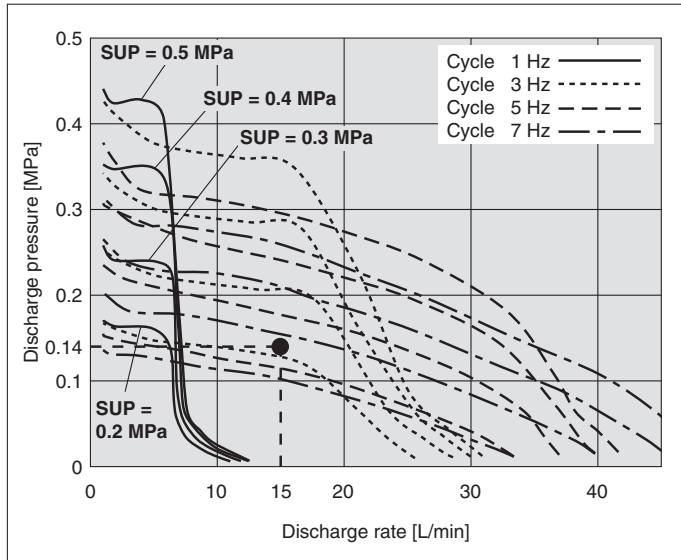

PA5⁰₂13-□06 Flow Rate Characteristics

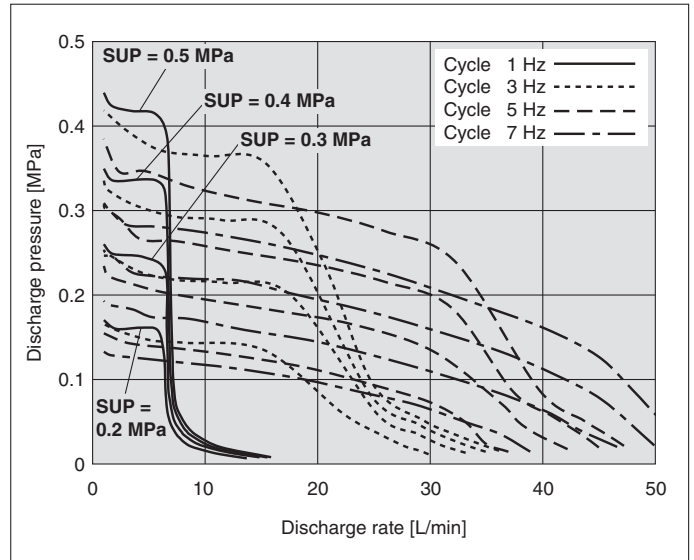

Selection from Flow Rate Characteristic Graph (PA5□13)

Required specification example:

Find the pilot air pressure for a discharge rate of 15 L/min and a discharge pressure of 0.14 MPa.

<The transferred fluid is fresh water (viscosity 1 mPa·s, specific gravity 1.0).>

If the total lifting height is required instead of the discharge pressure, a discharge pressure of 0.1 MPa corresponds to a total lift of 10 m.

Selection procedures:

1. First, mark the intersection point for a discharge rate of 15 L/min and a discharge pressure of 0.14 MPa.
2. Find the pilot air pressure for the marked point. In this case (3 Hz switching cycle), the point is between the discharge curves (dashed lines) for SUP = 0.2 MPa and SUP = 0.3 MPa, and based on the proportional relationship to these lines, the pilot air pressure for this point is approx. 0.22 MPa.

⚠ Caution

1. These flow rate characteristics are for fresh water (viscosity 1 mPa·s, specific gravity 1.0).
2. The discharge rate differs greatly depending on properties (viscosity, specific gravity) of the fluid being transferred and operating conditions (lifting range, transfer distance).

PA5⁰₂13 Air Consumption

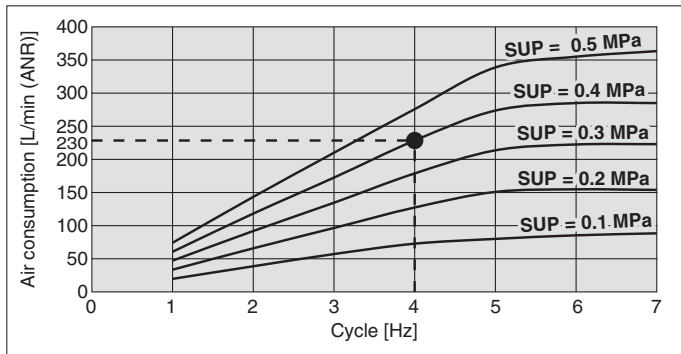

Calculating Air Consumption (PA5□13)

Find the air consumption for operation with a 4 Hz switching cycle and pilot air pressure of 0.4 MPa from the air consumption graph.

Selection procedures:

1. Look up from the 4 Hz switching cycle to find the intersection with SUP = 0.4 MPa.
2. From the point just found, draw a line to the Y-axis to find the air consumption. The result is approx. 230 L/min (ANR).

⚠ Caution

1. The air consumption differs greatly depending on properties (viscosity, specific gravity) of the fluid being transferred and operating conditions (lifting range, transfer distance).

PA5000 Series

Working Principle

Automatically Operated Type

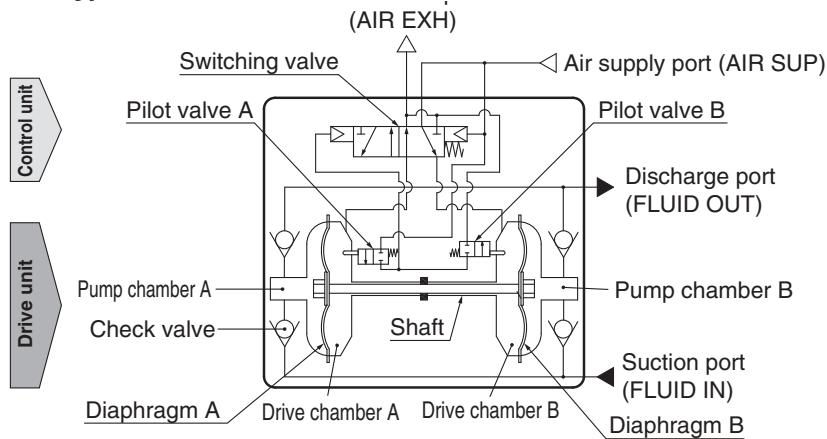

Control unit

1. When air is supplied, it passes through the switching valve and enters drive chamber B.
2. Diaphragm B moves to the right, and at the same time diaphragm A also moves to the right pushing pilot valve A.
3. When pilot valve A is pushed, air acts upon the switching valve, drive chamber A switches to a supply state, and the air which was in drive chamber B is exhausted to the outside.
4. When air enters drive chamber A, diaphragm B moves to the left pushing pilot valve B.
5. When pilot valve B is pushed, the air which was acting upon the switching valve is exhausted, and drive chamber B once again switches to a supply state. A continuous reciprocal motion is generated by this repetition.

Drive unit

1. When air enters drive chamber B, the fluid in pump chamber B is forced out, and at the same time fluid is sucked into pump chamber A.
2. When the diaphragm moves in the opposite direction, the fluid in pump chamber A is forced out, and fluid is sucked into pump chamber B.
3. Continuous suction and discharge is performed by the reciprocal motion of the diaphragm.

Air Operated Type

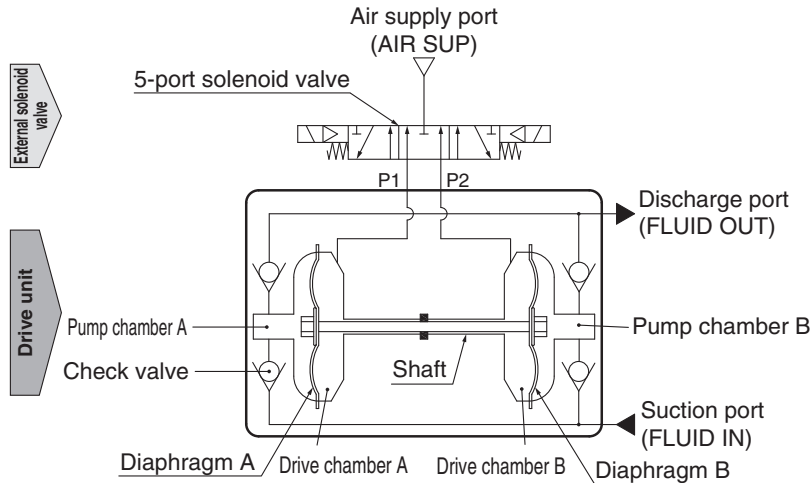

1. When air is supplied to P1 port, it enters drive chamber A.
2. Diaphragm A moves to the left, and at the same time diaphragm B also moves to the left.
3. The fluid in pump chamber A is forced out to the discharge port, and the fluid is sucked into pump chamber B from the suction port.
4. If air is supplied to the P2 port, the opposite will occur. Continuous suction and discharge of fluid is performed by repeating this process with the control of an external solenoid valve (5-port valve).

Maintenance Parts

- !** • Basically, it is not recommended to disassemble the process pump. However, if this is necessary, be sure to follow the instructions in the maintenance procedure.
- When carrying out this work, wear appropriate protective equipment.

Description	PA5000 (Aluminum/Stainless steel)			PA5000 (Polypropylene)	
	PA5 ₂ 10	PA5 ₂ 20	PA5 ₂ 13	PA5010	PA5013
Diaphragm kit	KT-PA5-31	KT-PA5-32	KT-PA5-31	KT-PA5-831	
Check valve kit	KT-PA5-36			KT-PA5-836	
Switching valve parts kit	KT-PA5-37		—	KT-PA5-37	—
Pilot valve kit	KT-PA5-38		—	KT-PA5-38	—
Manual cap assembly kit	KT-PA5-45		—	KT-PA5-45	—

Piping and Operation: Automatically Operated Type

Piping diagram

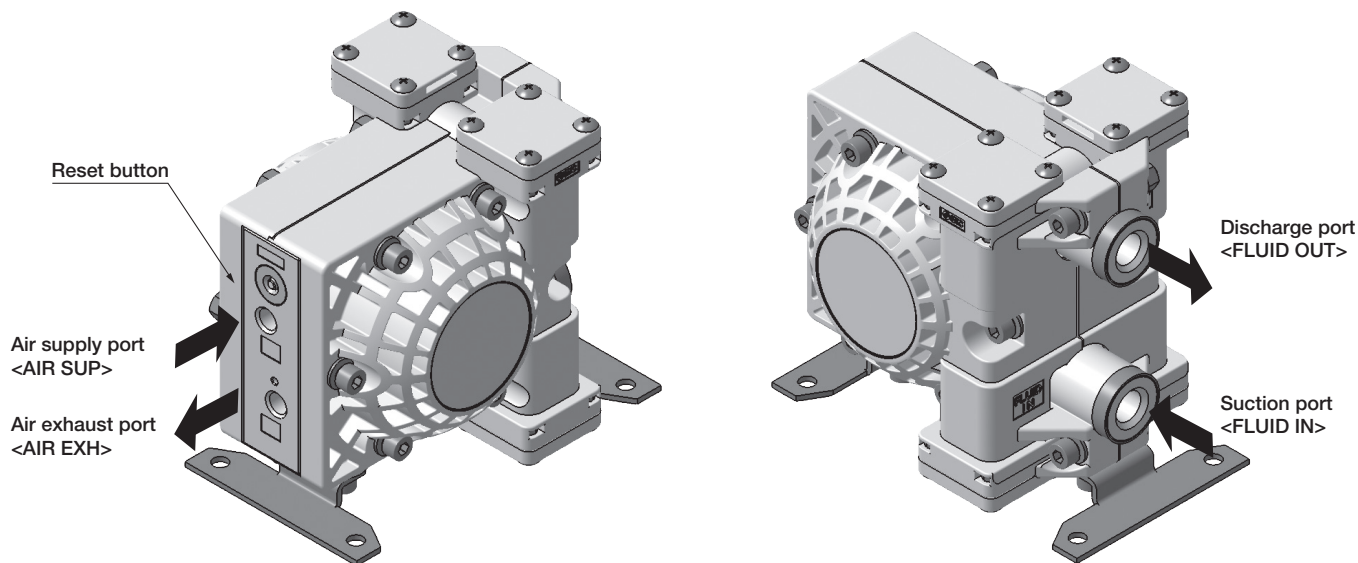

⚠ Caution

Mounting posture of the pump is set with the mounting bracket facing downward. Air to be supplied to the air supply port <AIR SUP> should be cleaned and filtered through AF filter, etc. Air with foreign matter or drainage etc. will have negative effects on the built-in directional control valve and will lead to malfunction. When air needs additional purification, use a filter (AF series), and a mist separator (AM series) together. Maintain the proper tightening torque for fittings and mounting bolts, etc. Looseness can cause problems such as fluid and air leaks, while over tightening can cause damage to threads and parts, etc.

Operation

<Starting and Stopping> Refer to circuit example (1).

1. Connect air piping to the air supply port <AIR SUP> and connect piping for the fluid to be transferred to the suction port <FLUID IN> and the discharge port <FLUID OUT>.
2. Using a regulator, set the pilot air pressure within the range of 0.2 to 0.7 MPa. Then, the pump operates when power is applied to the 3-port solenoid valve of the air supply port <AIR SUP>, the sound of exhaust begins from the air exhaust port <AIR EXH> and fluid flows from the suction port <FLUID IN> to the discharge port <FLUID OUT>.
At this time, the throttle on the discharge side is in an open state. The pump performs suction with its own power even without priming. (Dry state suction lifting range: max. 2 m) To restrict exhaust noise, attach a silencer (AN20-02: option) to the air exhaust port <AIR EXH>.
3. To stop the pump, exhaust the air pressure being supplied to the pump by the 3-port solenoid valve of the air supply port <AIR SUP>. The pump will also stop if the throttle on the discharge side is closed.

<Discharge Flow Rate Adjustment>

1. To adjust the flow rate from the discharge port <FLUID OUT>, use the throttle connected to the discharge side. Refer to circuit example (1). Note that this product cannot be used as a fixed quantity liquid dispense pump.
2. When operating with a discharge flow rate below the specification range, provide a by-pass circuit from the discharge side to the suction side to ensure the minimum flow rate inside the process pump. With a discharge flow rate below the minimum flow rate, the process pump may stop due to unstable operation. Refer to circuit example (2). (Minimum flow rate 5 L/min)

<Reset Button>

In cases where the pump does not operate even when air is supplied, etc., push the reset button in by 2 to 3 mm. The pump should restart. When the reset button needs to be pressed frequently, replacement of the whole product or maintenance of the switching valve is required.

Circuit example (1)

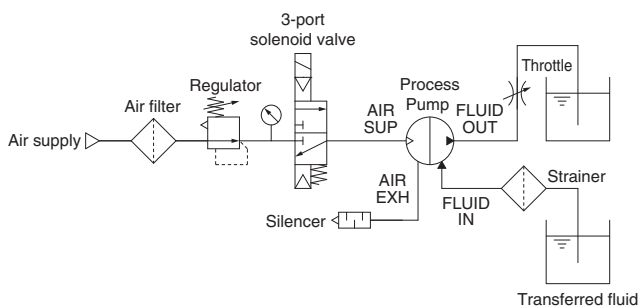

Circuit example (2)

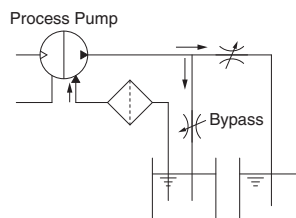

PA5000 Series

Piping and Operation: Air Operated Type

Piping diagram

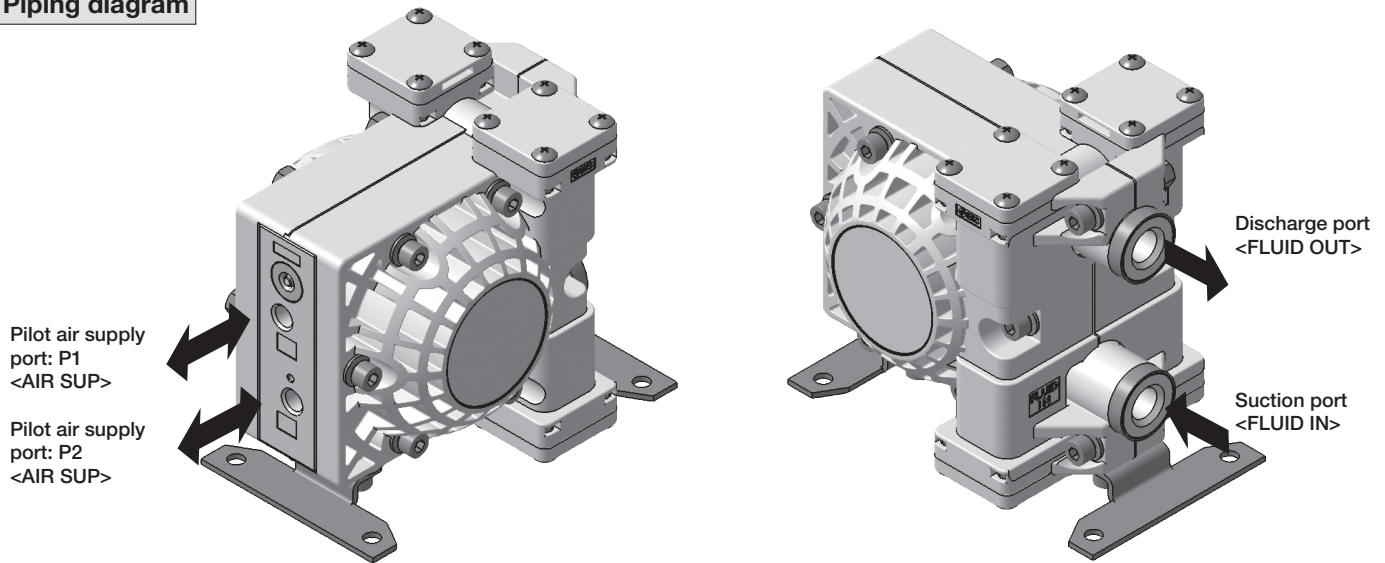

Recommended Valve

PA5□13	VQZ24□0 (Exhaust center)
--------	--------------------------

⚠ Caution

Maintain the proper tightening torque for fittings and mounting bolts, etc. Looseness can cause problems such as fluid and air leaks, while over tightening can cause damage to threads and parts, etc.

Operation

<Starting and Stopping> Refer to circuit example.

1. Connect air piping*1 to the pilot air supply port <P1>, <P2> and connect piping for the fluid to be transferred to the suction port <FLUID IN> and the discharge port <FLUID OUT>.
2. Using a regulator, set the pilot air pressure within the range of 0.1 to 0.5 MPa. Then, the pump operates when power is applied to the solenoid valve*2 of the pilot air supply port and fluid flows from the suction port <FLUID IN> to the discharge port <FLUID OUT>. At this time, the throttle on the discharge side is in an open state. The pump performs suction with its own power even without priming. (Dry state suction lifting range: Up to 0.5 m) To restrict exhaust noise, attach a silencer to the solenoid valve air exhaust port.
3. To stop the pump, exhaust the air pressure being supplied to the pump with the solenoid valve of the air supply port.

*1 When used for highly permeable fluids, the solenoid valve may malfunction due to the gas contained in the exhaust. Implement measures to keep the exhaust from going to the solenoid valve side.

*2 For the solenoid valve, use an exhaust center 5-port valve, or a combination of residual exhaust 3-port valve and a pump drive 4-port valve. If air in the drive chamber is not released when the pump is stopped, the diaphragm will be subjected to pressure and its life will be shortened.

<Discharge Flow Rate Adjustment>

1. The flow rate from the discharge port <FLUID OUT> can be adjusted easily by changing the switching cycle of the solenoid valve on the air supply port.

Circuit example (1)

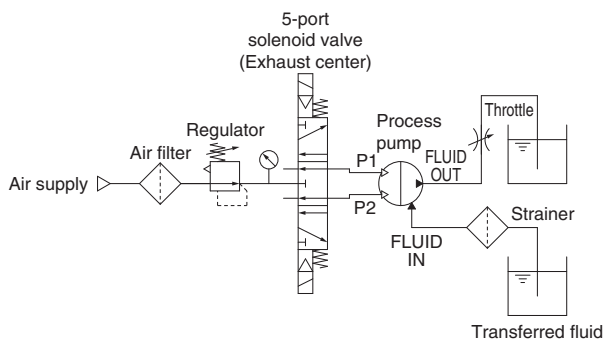

Circuit example (2)

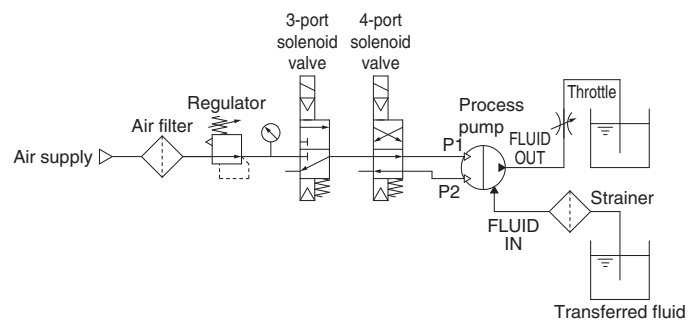

Dimensions

PA5₂¹□0/Automatically Operated Type (ADC12/SCS14 specification)

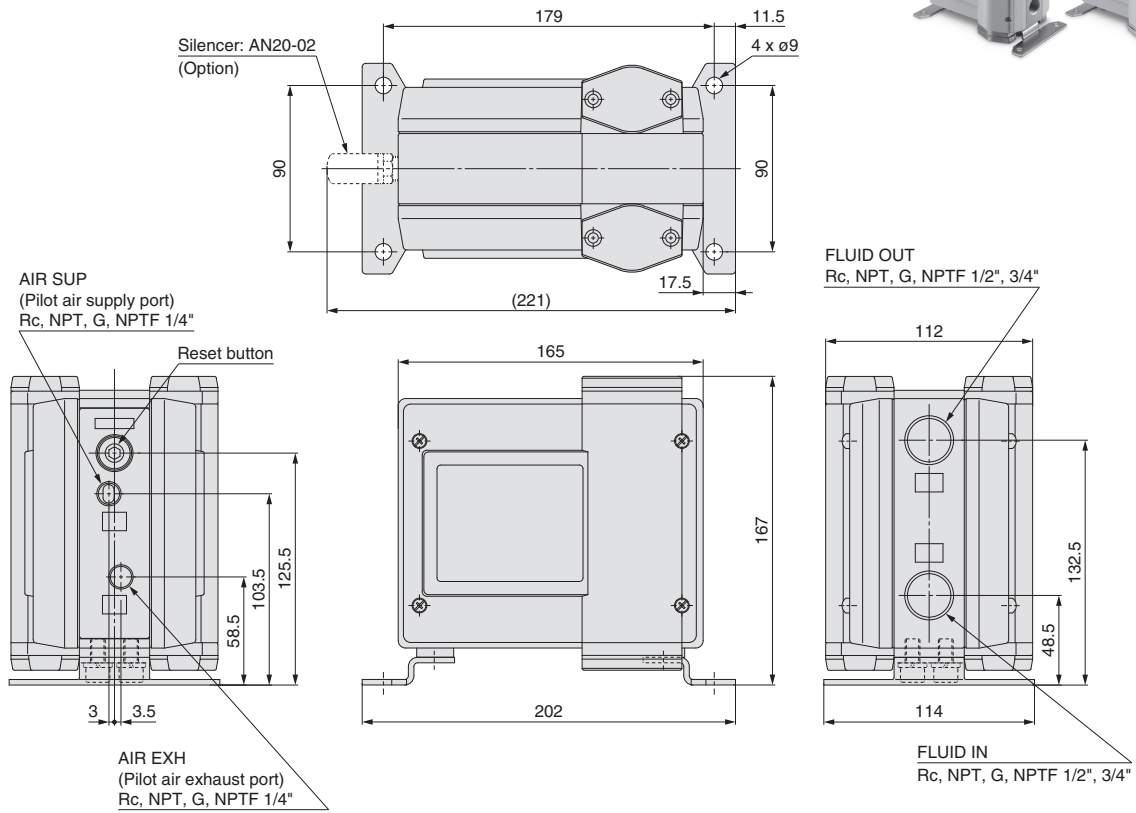

PA5₂¹13/Air Operated Type (ADC12/SCS14 specification)

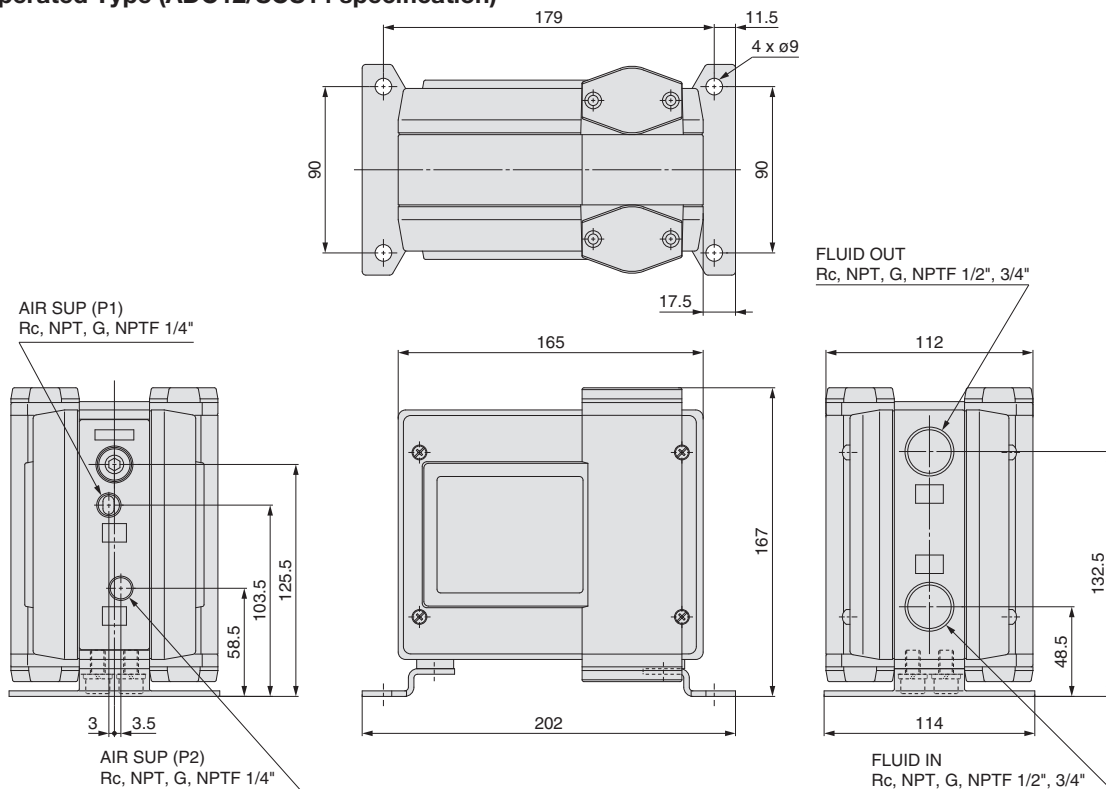

PA5000 Series

Dimensions

PA5010/Automatically Operated Type (PP specification)

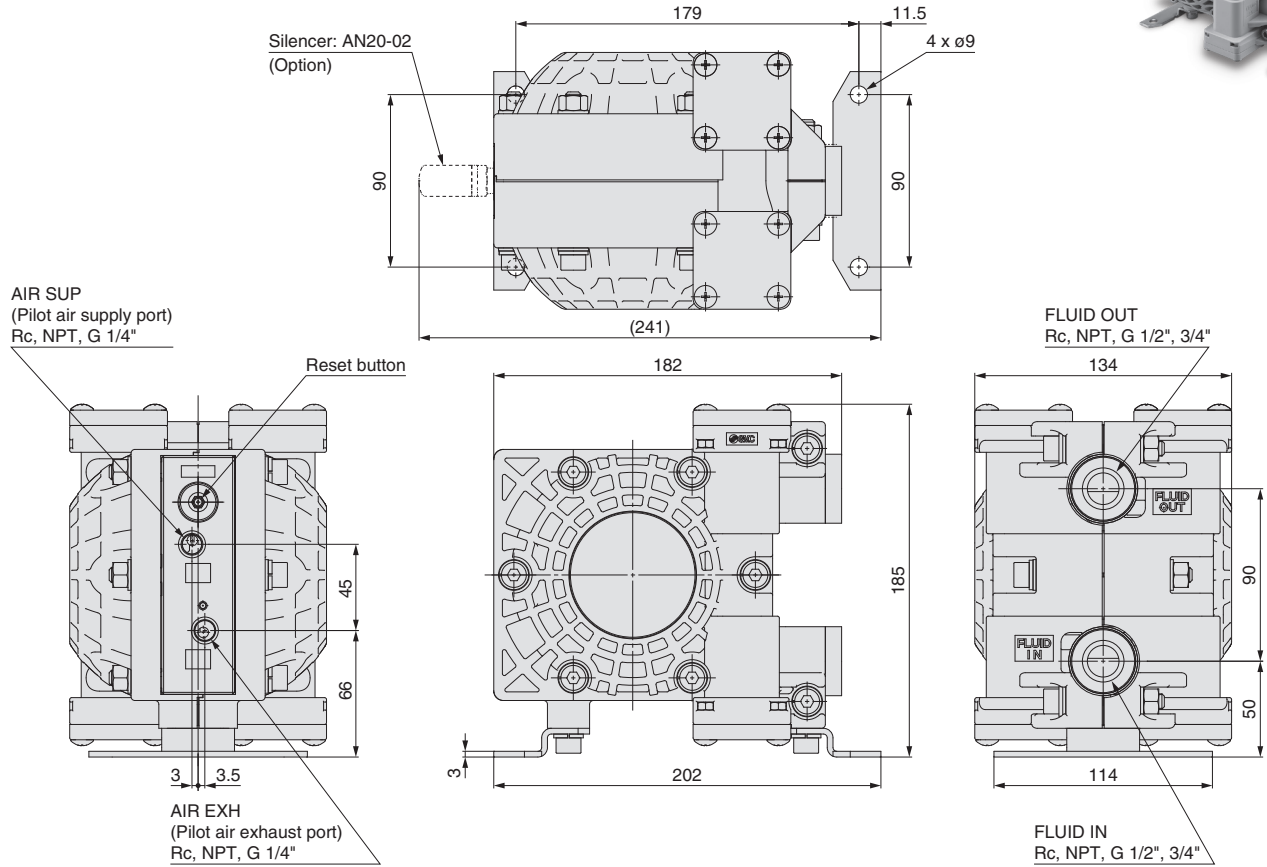
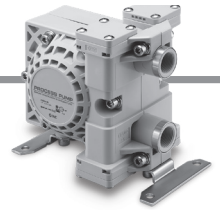

PA5013/Air Operated Type (PP specification)

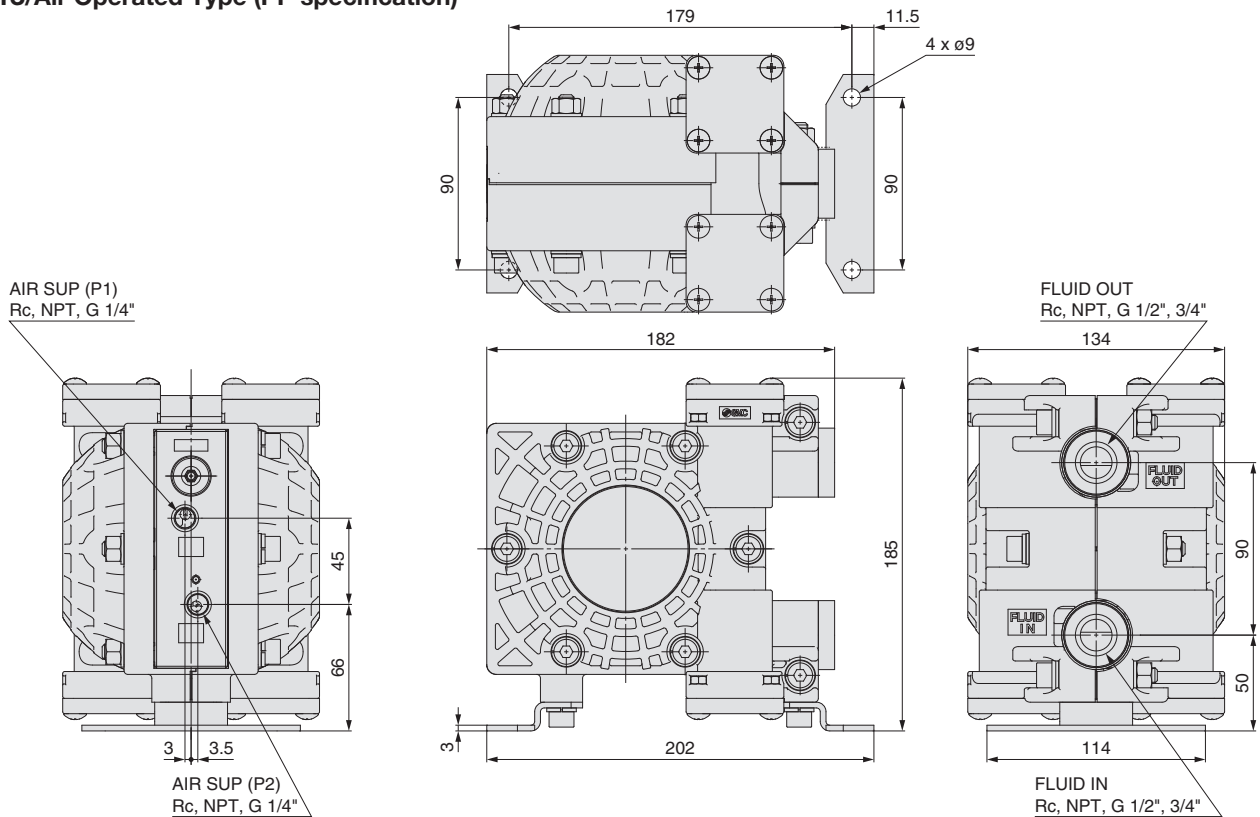

Made to Order Specifications



Please contact SMC for detailed dimensions, specifications, and delivery times.

1. Products Complying with ATEX

55 - PA5 **1** **1** **0** - **04** -

Products complying with the ATEX Directive

55	Products complying with the ATEX Directive, Category 2
56	Products complying with the ATEX Directive, Category 3

Fluid contact body material

Symbol	Fluid contact body material
1	ADC12 (Aluminum)
2	SCS14 (Stainless steel)

Diaphragm material

Symbol	Diaphragm material	Operating method	
		Automatically operated	Air operated
1	PTFE	●	●
2	NBR	●	—

* Dimensions are the same as those of the standard products.

Actuation

Symbol	Actuation
0	Automatically operated
3	Air operated

Option

Symbol	Option	Operating method	
		Automatically operated	Air operated
Nil	None	●	●
N	With silencer*1	●	—

*1 For AIR EXH

55-PA: 2504-□002

56-PA: AN20-□02

(For thread types, leave the □ box blank or enter N.)

Port size

Symbol	Port size
04	1/2"
06	3/4"

Thread type

Symbol	Type
Nil	Rc
N	NPT
F	G
T	NPTF

PA5000 Series

2. With Air Operated Reset Port

PA5 1 1 0 - 04 - X2

● Fluid contact body material

Symbol	Fluid contact body material
1	ADC12 (Aluminum)
2	SCS14 (Stainless steel)
0	PP (Polypropylene)

● Made to Order specifications

X2	With air operated reset port
----	------------------------------

● Option

Symbol	Option
Nil	None
N	With silencer*1

*1 For AIR EXH: AN20-□02
(For thread types, leave the □ box blank or enter N.)

● Port size

Symbol	Port size
04	1/2"
06	3/4"

● Thread type

Symbol	Type	Applicable fluid contact body material		
		ADC12 (Aluminum)	SCS14 (Stainless steel)	PP (Polypropylene)
Nil	Rc	●	●	●
N	NPT	●	●	●
F	G	●	●	●
T	NPTF	●	●	—

● Diaphragm material

Symbol	Diaphragm material	Applicable fluid contact body material		
		ADC12 (Aluminum)	SCS14 (Stainless steel)	PP (Polypropylene)
1	PTFE	●	●	●
2	NBR	●	●	—

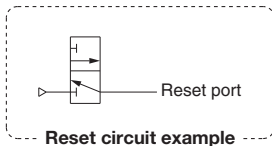

PA51□0/52□0

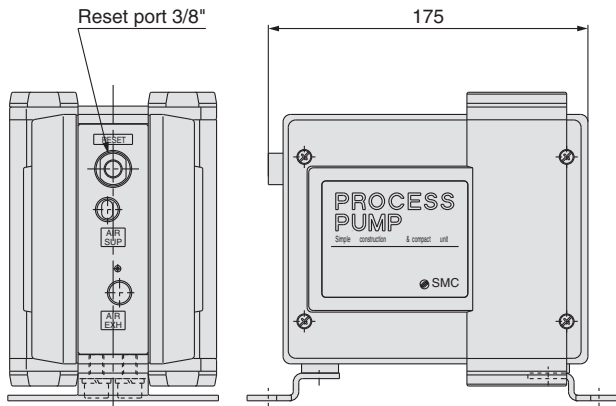

PA5010

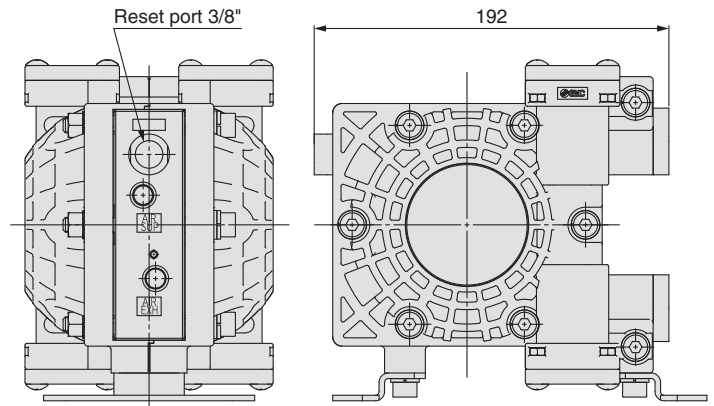

3. With Operating Cycle Counting Port

PA5 1 1 0 - [] 04 - [] - X8

● **Fluid contact body material**

Symbol	Fluid contact body material
1	ADC12 (Aluminum)
2	SCS14 (Stainless steel)
0	PP (Polypropylene)

● **Made to Order specifications**

X8	With operating cycle counting port
----	------------------------------------

● **Option**

Symbol	Option
Nil	None
N	With silencer*1

*1 For AIR EXH: AN20-[]02
(For thread types, leave the [] box blank or enter N.)

● **Port size**

Symbol	Port size
04	1/2"
06	3/4"

● **Thread type**

Symbol	Type	Applicable fluid contact body material		
		ADC12 (Aluminum)	SCS14 (Stainless steel)	PP (Polypropylene)
Nil	Rc	●	●	●
N	NPT	●	●	●
F	G	●	●	●
T	NPTF	●	●	—

● **Diaphragm material**

Symbol	Diaphragm material	Applicable fluid contact body material		
		ADC12 (Aluminum)	SCS14 (Stainless steel)	PP (Polypropylene)
1	PTFE	●	●	●
2	NBR	●	●	—

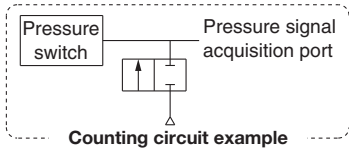

PA51[]0/52[]0

Pressure signal acquisition port M5

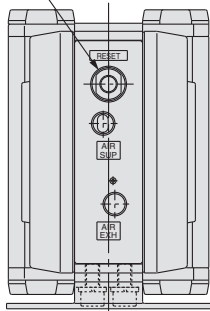

171

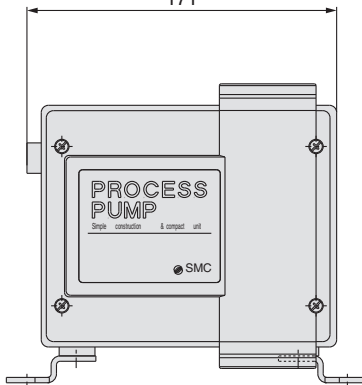

PA5010

Pressure signal acquisition port M5

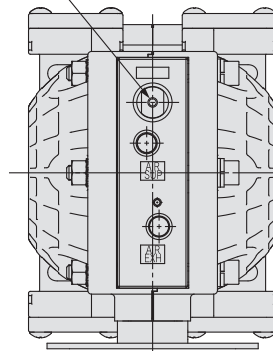

188

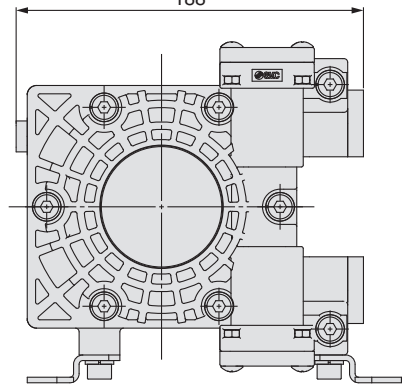



PA5000 Series Applicable Fluids

Material and Fluid Compatibility Check List for Process Pumps

- The data below is prepared based on data provided by the material manufacturers.
- SMC assumes no responsibility for the accuracy of the data or for any damages arising from the data.
- The material and fluid compatibility check list provides reference values as a guide only; therefore SMC does not guarantee the application to our product.

⚠ Caution

- Select the wetted parts materials according to the transferred liquid you use to determine the model.
 - Fluid contact materials: aluminum is suitable for oils, stainless steel is suitable for solvents and industrial water, and PP is suitable for water, acids and alkali fluids.
 - For the diaphragm material, NBR is suitable for inert liquids, and PTFE is suitable for non-permeating liquids.
 - Use fluids that will not corrode the wetted parts materials.
- These products are not suitable for medical or food use.
- The applicability may vary depending on additives. Take note also of additives.
- The applicability may vary depending on impurities. Take note also of impurities.
- Examples of transferred liquids are shown below. Since the applicability may vary depending on your operating conditions, be sure to check it by means of experimentation.
- The compatibility shown in the table is when the fluid temperature is within the product specification (60°C or less).

PA5000 Series

Table symbols ○: Can be used. ×: Cannot be used. —: Can be used under certain conditions. Please consult us.

Model		PA5110	PA5113	PA5120	PA5210	PA5213	PA5220	PA5010	PA5013	
Body material		ADC12			SCS14			PP		
Diaphragm material		PTFE		NBR	PTFE		NBR	PTFE		
Examples of applicable liquids	Water	Tap water				○			○	
		Pure water				—			—	
	Oil	Turbine oil		○			○			○
		Cutting oil	○			○				○
		Brake oil	○			○				○
	Solvent	Flux				○				—
		Toluene	○*2			○*2				—
		Methyl ethyl ketone				○*2				—
		Acetone				○*2				—
		Inert solvent					○			○*2
		Ethyl alcohol	○*2			○*2				—
		Isopropyl alcohol	○*2			○*2				—
		Sodium hypochlorite								—
		Acids								○*3
		Alkalis								○*3
		Metal corrosive liquid								×
	Highly permeating liquid								×	
	Highly penetrating liquid		○*1			○*1			○*1	

*1 The air operated types can also be used for highly penetrating liquids. However, they cannot be used if the penetrating components damage parts such as seals in the air circuit. In addition, since the exhaust air contains the gas components penetrating through the diaphragm, take measures to prevent the exhaust air from going to the solenoid valve.

*2 Static electricity may be generated. Take measures to prevent static electricity.

*3 Strong acidic chemicals, strong basic chemicals, and hydrofluoric acid are not allowed.

* These may be penetrated by fluids, and the penetrating fluids may affect parts of other materials.



PA5000 Series

Specific Product Precautions 1

Be sure to read this before handling the products.
Refer to the back cover for safety instructions.

Caution on Design

⚠ Warning

1. Confirm the specifications.

Give careful consideration to operating conditions such as the application, fluid and environment, and use the product within the operating ranges specified in this catalog.

2. Fluids

- When ignitable fluid is used, select a product with metal wetted parts (aluminum, stainless steel). Always take countermeasures against static electricity.
- For the compatibility between the materials composing the product and the fluids, check the compatibility check list. Since the compatibility of the fluid used may vary depending on its type, additives, concentration, temperature, etc., give sufficient consideration when selecting the material.
- For fluids other than those listed on the check list, please consult us. Also, use them within the range of the operating fluid temperatures.
- If foreign matter is mixed in the fluid, these may cause abrasion of the inside of the pump resulting in a problem. Use an appropriate filter (strainer) to remove them. In general, 80 to 100 mesh (150 to 180 μm) filters are recommended.
- When transferring a coagulable liquid, take measures to prevent it from coagulating in the pump.
- Please contact an SMC sales office if use with slurry is required.
- Take countermeasures to prevent the operating fluid from getting onto the body of the process pump.

3. Water hammer

If a valve is operated abruptly etc., a high pressure may be applied due to water hammer. Take measures to prevent pressures higher than specified from being applied.

<Examples of measures>

- Use a water hammer resistant valve to reduce the valve closing speed.
- Use an elastic piping material such as rubber hose or an accumulator to absorb the impact pressure.

4. Liquid seals

To ensure that fluid does not become sealed inside the process pump, when stopping the pump, relieve the discharge pressure inside it. As shown in the figure at right, make a circuit which has a relief valve installed on the system.

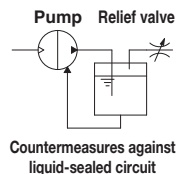

5. Fluid pressure supplied to the process pump

Feeding the fluid from the suction side into the pump under pressure, or drawing it using a negative pressure, will reduce the life of the pump.

6. Ensure space for maintenance.

Secure the space required for maintenance and inspection. Take into consideration also leakage from the product. When transferring a flammable liquid or a liquid that may affect the human body or environment, take measures including fire ban and keeping the area off limits.

7. When the diaphragm is broken, supply air will be mixed with the fluid or fluid will enter the air switching valve. When the supply air or debris contained in it affect the product performance, or the supply air is not suitable for the chemical resistance of the components, countermeasures need to be taken by the customer.

⚠ Warning

8. Use a design which prevents reverse pressure and reverse flow.

If reverse pressure or reverse flow occurs on the discharge side of the process pump, the equipment is liable to become damaged or malfunction. Take safety measures in designing the circuit.

9. Measures against static electricity

Take measures against static electricity as static electricity may occur depending on the fluid. Particularly, when circulating flammable fluid through the pump, be sure to take measures to prevent the occurrence of static electricity.

10. The pump cannot transfer gas. Do not allow it to idle for a long time.

If the pump is operated for a long time without any fluid inside or in a gas-fluid mixed state, the diaphragm may be damaged or the life may be shortened. Dry operation is only allowed during self-priming.

11. Condensation and freezing of the pilot port

The location around the switching valve and the air exhaust port of the automatically operated type and also the air supply port of the air operated type can cool down quickly due to expansion of the supply air, and this may cause condensation on the piping and the condensation may freeze during operation in winter. Take measures to ensure that water droplets from condensation are not splashed onto any electric parts or equipment.

⚠ Caution

1. Suspension of the pump operation

● PA□ series

- For the automatically operated type, use a 3-port solenoid valve and be sure to discharge the residual pressure. If the process pump is stopped while air is still being supplied to it, a load will be applied to the internal parts of the pump, reducing the life of the pump. Also, if the pump should stop while consuming the residual pressure, the built-in pilot air switching unit may become unstable and unable to be restarted. If it cannot be restarted, press the reset button.
- For the air operated type, combine an exhaust center 5-port solenoid valve or a 3-port solenoid valve for residual pressure release and a 4-port solenoid valve for driving the pump to discharge the residual pressure inside the pump when stopping it. If the pump is pressurized during suspension, its life will become shorter.

2. Use the constant pilot air pressure.

In the automatically operated type, when the pressure fluctuation of the pilot air exceeds 50 kPa, a malfunction could occur and the pump may stop.

3. Reverse flow

The check valve inside the process pump does not completely stop reverse flow (the flow from the discharge side to the suction side). For this reason, fluid may sometimes flow from the discharge side to the suction side when the pump is stationary, etc). As a countermeasure, install a 2-way valve or a check valve. However, please note that when a check valve is installed, if the cracking pressure is high, defective suction may occur. (As a guide, the cracking pressure should be 0.02 MPa or less.)



PA5000 Series

Specific Product Precautions 2

Be sure to read this before handling the products.

Refer to the back cover for safety instructions.

Mounting

⚠ Caution

1. Read the operation manual before mounting the product.

Read the operation manual carefully and understand the contents before mounting the product. The manual should also be kept where it can be referred to whenever necessary.

2. Confirm the mounting orientation of the product.

Only horizontal mounting is available. Attach the product so that the mounting feet face down.

Also, secure all specified mounting positions when using the product.

If the propagation of the vibration of the pump is not acceptable, insert vibro-isolating rubber when mounting.

Piping

⚠ Caution

1. Flush the piping.

Flush and clean the piping before connecting the product. Any dirt or scale and the like left in the piping may cause a malfunction or failure.

2. Use fittings with resin threads when connecting piping to the product with resin threads at the ports.

Using fittings with metal threads may cause damage to the ports.

3. Tighten screws with proper tightening torque.

When screwing fittings into the product, tighten them with proper tightening torque as shown below.

If loose, liquid or air leakage may occur. If overtightened, the threaded parts may be damaged.

PA5¹₂□□

Connection thread	Proper tightening torque [N·m]
Rc, NPT, G, NPTF 1/4	12 to 14
Rc, NPT, G, NPTF 1/2	28 to 30
Rc, NPT, G, NPTF 3/4	28 to 30

PA50□□

Connection thread	Proper tightening torque [N·m]
Rc, NPT, G 1/4	12 to 14
Rc, NPT, G 1/2	2 to 2.5
Rc, NPT, G 3/4	4 to 5

Air Supply

⚠ Warning

1. Use clean air.

Do not use compressed air that includes chemicals, synthetic oils containing organic solvents, salinities or corrosive gases, etc., as it can cause damage or malfunction.

2. Pay attention to avoid freezing when operating the product in low temperatures.

The equipment operates while expanding the compressed air. During this time, the temperature inside the product decreases due to adiabatic expansion. If the ambient temperature is low, using compressed air containing a lot of moisture may cause freezing because heat cannot be gained from the surroundings. In this case, take freeze prevention measures by using a membrane air dryer (such as IDG series).

⚠ Caution

1. Quality of operating air

- Be sure to use only air filtrated by a micro mist separator (such as AMD series). Use of a super mist separator (such as AME series) is recommended to extend maintenance intervals.
- Use of humid air may cause condensation inside the body. Use air which has been treated by a refrigerated air dryer (such as IDF series).
- If a pump is operated by N₂ gas, etc., the deterioration of the gaskets inside the switching valve will be accelerated and may result in substantially shortening the life span of the product.

2. Compressed air with low dew point

If compressed air with an atmospheric pressure dew point below -40°C is used, the lubrication properties inside the product can deteriorate prematurely, affecting the life of the product. When air with an atmospheric pressure dew point below -40°C is used for the operating environment or operating fluid, it is recommend that the customer tests the product under their own specific operating conditions.

Operating Environment

⚠ Warning

1. Do not use in the following environments, as this can cause failure.

- 1) Locations with an atmosphere of corrosive gases, organic solvents or chemical solutions, and where there may be contact with the same.
- 2) Locations where there is contact with sea spray, water or steam.
- 3) Locations where ultraviolet deterioration or overheating of resin may occur due to direct sunlight.
- 4) Locations near heat sources with poor ventilation (heat sources should be shielded by heat insulating material).
- 5) Locations with impact or vibration.
- 6) Locations with excessive moisture and dust.

2. The product cannot be used under water.

Do not use the product immersing it in water (liquid). Otherwise, liquid will enter the openings inside the product, resulting in a malfunction.

3. Depending on the fluid used, a flammable atmosphere may occur. Take countermeasures such as ventilation.



PA5000 Series

Specific Product Precautions 3

Be sure to read this before handling the products.
Refer to the back cover for safety instructions.

Maintenance

Warning

1. Perform maintenance after consulting the operation manual.

Obtain the operation manual for the equipment from SMC or our distributor and have sufficient knowledge of the equipment before performing maintenance. Incorrect handling may cause damage or malfunction of the equipment or system.

2. Perform maintenance work after confirming the safety of the system.

Turn off the compressed air and power supply and exhaust any remaining compressed air in the system before removing the equipment and the compressed air supply/exhaust unit. Discharge the residual liquid or sufficiently displace it as necessary. Also, when reinstalling the equipment or restarting it after replacement, confirm the safety of the product before checking that it operates normally.

3. Use appropriate protective equipment.

When touching the process pump for maintenance, wear protective equipment such as gloves which are compatible with the fluid used. There is a risk of chemical burns.

4. Do not disassemble the product, as disassembly will invalidate the product's warranty.

When disassembly is necessary, please consult with SMC or our distributor.

5. Drain discharge

Operating the system with drain accumulated in the equipment or piping may cause a malfunction of the equipment, splash over into the downstream side, or unexpected accident. Periodically discharge drain from components including the air filter.

6. Caution when transferring a high-temperature fluid

The product itself will become hot due to the high-temperature fluid. Since touching the product directly may cause burns, allow sufficient time for the product to cool down when transferring a high-temperature fluid. The measurement of the product temperature is recommended to confirm the safety of the system before performing work.

7. The bolts in this product may become loose over time due to creep of the PP housing. Retighten the bolts before operation to prevent fluid or air leakage (refer to the maintenance manual for the required tightening torque).

Caution

1. Caution when transferring a highly penetrating liquid

When transferring a liquid that is highly penetrating through fluoropolymer, components of the transferred liquid may enter the openings inside the equipment. Also, they may become attached to the external surface of the equipment. In this case, take the same measures as handling the transferred liquid.

Caution

2. Service life of diaphragm and maintenance of consumable items

- If the operating cycle of the process pump exceeds the service life of diaphragm, the diaphragm may be damaged due to deterioration. If it is damaged, the fluid will leak from the pilot air exhaust port and the air will blow out into the liquid circuit. Consider the pump operation (breathing, decline of discharge pressure, etc.) and the reference service life of diaphragm, and replace with new process pump or conduct necessary maintenance as early as possible.
- Items such as check valves, switching valves, pilot valves and manual caps may experience a malfunction earlier than the diaphragm depending on the operating conditions. Replacement of the whole product or maintenance should be performed as soon as possible.
- When conducting maintenance, obtain the necessary parts indicated in the maintenance parts list (Refer to each series), and perform work according to the maintenance and operation manuals.

3. Please understand the following concerning the inability to repair the product.

- To enable the process pump to be used with various fluids, please note that from the aspects of ensuring worker safety and also the facilities, SMC is unable to carry out repair.

[Calculation of reference service life (days) of diaphragm]

<Automatically operated type>

$$\text{Reference service life (days)} = \frac{A (\text{Amount of discharge per cycle}) \times B (\text{Reference number of cycles in service life})}{\text{Flow rate (L/min)} \times \text{Operating time per day (hour)} \times 60 (\text{min})}$$

<Air operated type>

The amount of discharge per cycle for the air operated type varies depending on the piping resistance. Therefore, calculate the service life (days) using the operating frequency of a solenoid valve.

$$\text{Reference service life (days)} = \frac{B (\text{Reference number of cycles in service life})}{\text{Operating frequency of solenoid valve (Hz)} \times 60 (\text{sec}) \times \text{Operating time per day (hour)} \times 60 (\text{min})}$$

Model	Operating method	Diaphragm material	Amount of discharge per cycle A	Reference number of cycles in service life B	Volume inside pump (wetted part)
PA5 ₂ ¹ 10	Automatically operated	PTFE	Approx. 0.10 L	50 million cycles	Approx. 315 mL
PA5 ₂ ¹ 20		NBR			
PA5 ₂ ¹ 13	Air operated	PTFE	Approx. 0.09 L*1	50 million cycles	Approx. 505 mL
PA5010	Automatically operated	PTFE	Approx. 0.10 L		
PA5013	Air operated	PTFE	Approx. 0.09 L		

*1 The amount of discharge per cycle for the air operated type is indicated assuming no piping resistance.

* These are reference values given for rated temperature and tap water and are not guaranteed.



PA5000 Series

Specific Product Precautions 4

Be sure to read this before handling the products.

Refer to the back cover for safety instructions.

Lubrication

Caution

1. The pump can be used without lubrication.

Do not lubricate the air operated type.

2. If lubricating the pump, continue lubrication.

If lubricating a pump other than the air operated type, use turbine oil Class 1 (with no additives) ISO VG32, and be sure to continue lubricating the pump.

Caution on Handling

Warning

1. Test before using with the actual equipment.

Test the pump before using it with the actual equipment. Even if there is no problem in a short-term test, the liquid may penetrate through the fluoropolymer diaphragm causing a malfunction in the pump air circuit.

2. Storage

In the case of long-term storage after use, first thoroughly remove the liquid, and clean and dry the inside to prevent deterioration of the pump materials.

3. After a long period of non-use, perform a trial run prior to operation.

4. Ensure that the bolts are not loose before operating the process pump.

5. Adjustment of the discharge amount

Connect the discharge volume adjustment valve (throttle) to the FLUID OUT port of the process pump. Adjust the volume by adjusting the opening of the valve.

6. When the discharge volume is large (flow velocity is high) depending on the fluid type and operating conditions, cavitation may lead to poor operation or failure. Increase supply air pressure or decrease the discharge volume with a throttle so that cavitation is not generated.

7. Operating environment

When dangerous fluid is used, take measures to isolate humans from the pump. External leakage of pumping fluid could cause serious injury.

8. Countermeasures against liquid leakage

There are some cases where the operating fluid will leak outside the pump, for example when the diaphragm reaches the end of the life. Measures should be taken to avoid leakage, such as installing a drain pan, so that people and equipment will not be adversely affected.

9. Caution for piping of the tube

Support the piping according to JIS B 8370 when piping the tube. Arrange the piping so that tension is not applied to the tube.

Return of Product

Warning

If the product to be returned is contaminated or is possibly contaminated with substances that are harmful to humans, for safety reasons, please contact SMC beforehand and then employ a specialist cleaning company to decontaminate the product. After the decontamination prescribed above has been carried out, submit a Product Return Request Sheet or the Detoxification/Decontamination Certificate to SMC and await SMC's approval and further instructions before attempting to return the item.

Please refer to the International Chemical Safety Cards (ICSC) for a list of harmful substances. If you have any further questions, please don't hesitate to contact your SMC sales representative.

Safety Instructions

These safety instructions are intended to prevent hazardous situations and/or equipment damage. These instructions indicate the level of potential hazard with the labels of “**Caution**,” “**Warning**” or “**Danger**.” They are all important notes for safety and must be followed in addition to International Standards (ISO/IEC)*1), and other safety regulations.

 **Caution:** **Caution** indicates a hazard with a low level of risk which, if not avoided, could result in minor or moderate injury.

 **Warning:** **Warning** indicates a hazard with a medium level of risk which, if not avoided, could result in death or serious injury.

 **Danger :** **Danger** indicates a hazard with a high level of risk which, if not avoided, will result in death or serious injury.

*1) ISO 4414: Pneumatic fluid power – General rules relating to systems.
ISO 4413: Hydraulic fluid power – General rules relating to systems.
IEC 60204-1: Safety of machinery – Electrical equipment of machines.
(Part 1: General requirements)
ISO 10218-1: Manipulating industrial robots – Safety.
etc.

Warning

1. The compatibility of the product is the responsibility of the person who designs the equipment or decides its specifications.

Since the product specified here is used under various operating conditions, its compatibility with specific equipment must be decided by the person who designs the equipment or decides its specifications based on necessary analysis and test results. The expected performance and safety assurance of the equipment will be the responsibility of the person who has determined its compatibility with the product. This person should also continuously review all specifications of the product referring to its latest catalog information, with a view to giving due consideration to any possibility of equipment failure when configuring the equipment.

2. Only personnel with appropriate training should operate machinery and equipment.

The product specified here may become unsafe if handled incorrectly. The assembly, operation and maintenance of machines or equipment including our products must be performed by an operator who is appropriately trained and experienced.

3. Do not service or attempt to remove product and machinery/equipment until safety is confirmed.

1. The inspection and maintenance of machinery/equipment should only be performed after measures to prevent falling or runaway of the driven objects have been confirmed.
2. When the product is to be removed, confirm that the safety measures as mentioned above are implemented and the power from any appropriate source is cut, and read and understand the specific product precautions of all relevant products carefully.
3. Before machinery/equipment is restarted, take measures to prevent unexpected operation and malfunction.

4. Contact SMC beforehand and take special consideration of safety measures if the product is to be used in any of the following conditions.

1. Conditions and environments outside of the given specifications, or use outdoors or in a place exposed to direct sunlight.
2. Installation on equipment in conjunction with atomic energy, railways, air navigation, space, shipping, vehicles, military, medical treatment, combustion and recreation, or equipment in contact with food and beverages, emergency stop circuits, clutch and brake circuits in press applications, safety equipment or other applications unsuitable for the standard specifications described in the product catalog.
3. An application which could have negative effects on people, property, or animals requiring special safety analysis.
4. Use in an interlock circuit, which requires the provision of double interlock for possible failure by using a mechanical protective function, and periodical checks to confirm proper operation.

Caution

1. The product is provided for use in manufacturing industries.

The product herein described is basically provided for peaceful use in manufacturing industries.
If considering using the product in other industries, consult SMC beforehand and exchange specifications or a contract if necessary.
If anything is unclear, contact your nearest sales branch.

Limited warranty and Disclaimer/ Compliance Requirements

The product used is subject to the following “Limited warranty and Disclaimer” and “Compliance Requirements”.

Read and accept them before using the product.

Limited warranty and Disclaimer

1. The warranty period of the product is 1 year in service or 1.5 years after the product is delivered, whichever is first.*2)
Also, the product may have specified durability, running distance or replacement parts. Please consult your nearest sales branch.
2. For any failure or damage reported within the warranty period which is clearly our responsibility, a replacement product or necessary parts will be provided.
This limited warranty applies only to our product independently, and not to any other damage incurred due to the failure of the product.
3. Prior to using SMC products, please read and understand the warranty terms and disclaimers noted in the specified catalog for the particular products.

*2) **Vacuum pads are excluded from this 1 year warranty.**

A vacuum pad is a consumable part, so it is warranted for a year after it is delivered.
Also, even within the warranty period, the wear of a product due to the use of the vacuum pad or failure due to the deterioration of rubber material are not covered by the limited warranty.

Compliance Requirements

1. The use of SMC products with production equipment for the manufacture of weapons of mass destruction (WMD) or any other weapon is strictly prohibited.
2. The exports of SMC products or technology from one country to another are governed by the relevant security laws and regulations of the countries involved in the transaction. Prior to the shipment of a SMC product to another country, assure that all local rules governing that export are known and followed.

Caution

SMC products are not intended for use as instruments for legal metrology.

Measurement instruments that SMC manufactures or sells have not been qualified by type approval tests relevant to the metrology (measurement) laws of each country. Therefore, SMC products cannot be used for business or certification ordained by the metrology (measurement) laws of each country.

Leading global pneumatics and industrial automation components manufacturer dedicated to sustainable factory automation.

Serving the industries of semiconductor, food & packaging, life science, automotive, machine tool, process, natural resource, and general needs for automation, controls, and process.



Global Presence

- **532 Sales Offices in 83 Countries**
- **Production Facilities in 29 Countries and Regions**
- **Technical Centers in Japan, the U.S., Europe, and China**

Extensive Product Line

- **12,000 Basic Models with over 700,000 variations**
 - *Actuators*
 - *Temperature Control*
 - *Sensors & Switches*
 - *Valves*
 - *Connectors*
 - *Air Preparation*
 - *Process Gas*
 - *Static Control*
 - *Electrical Products*
 - *Chemical Handling*
 - *Vacuum*
 - *Specialty Products*

North American Support

- **30 North American Locations**
- **Configure, Validate, and Download 3D & 2D CAD Models from www.smcusa.com/products/**
- **2.6m sqft North American headquarters of Engineering, Production, Central Distribution and Administration**

U.S. & Canadian Sales Offices

WEST	CENTRAL	EAST
Austin	Chicago	Atlanta
Dallas	Cincinnati	Birmingham
Denver	Cleveland	Boston
El Paso	Detroit	Charlotte
Los Angeles	Des Moines	Knoxville
Phoenix	Grand Rapids	Nashville
Portland	Indianapolis	New Jersey
San Jose	Kansas City	Rochester
	Milwaukee	Tampa
	Minneapolis	
	St. Louis	
CANADA		
Montreal		
Toronto		

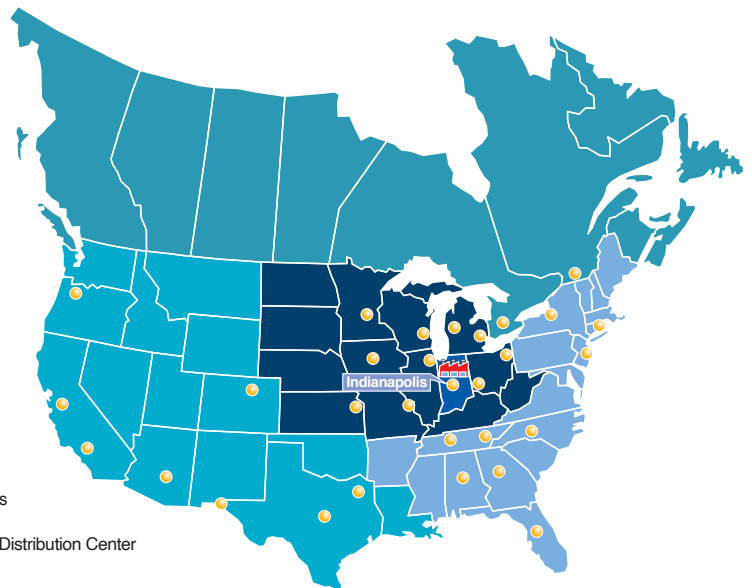

● Sales Offices
 Production/Distribution Center

o o o o e c



r s e s s c s c o
 r s c o c o

