

Air Gripper Unit for Collaborative Robots

YASKAWA Electric Corporation
collaborative robots
MOTOMAN-HC10/HC10DT compliant



Air gripper unit
for the MOTOMAN-HC10

Air gripper unit
for the MOTOMAN-HC10DT



JMHZ2-X7400B-HC10/HC10DT



More information

P-E20-21

Air Gripper Unit for Collaborative Robots

YASKAWA Electric Corporation collaborative robots

MOTOMAN-HC10/HC10DT compliant



- Compact, lightweight product with high gripping force due to air operation
- An air gripper that realizes high rigidity and high precision due to its guide-integrated construction

With high-precision linear guide

Repeatability: ± 0.01 mm

Linear guide of the higher rigidity and precision is used.

Higher rigidity (Compared with the same size of the existing MHZ2)

- 1 air supply tube and the electric wiring can be operated simply by connecting the annex cable.
- Integrated solenoid valve, speed adjustment mechanism, and auto switch
- A split protective cover for easy air gripper maintenance
Allows you to maintain the air gripper without removing the user-specific attachment

Component Parts

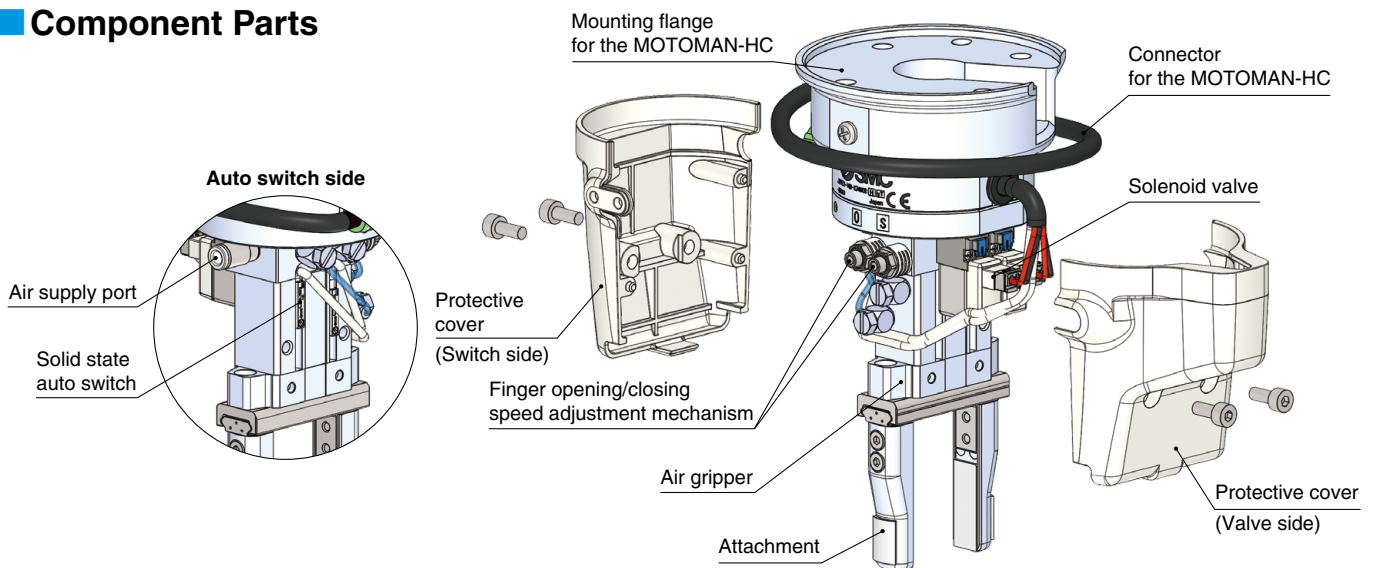

How to Order



JMHZ2-16D-X7400B-HC10-P

Compatible robot

HC10	MOTOMAN-HC10
HC10DT	MOTOMAN-HC10DT

* The supplied flange differs depending on the product number.

Auto switch output type

Symbol	Auto switch model	Output type
N	D-M9N-5	NPN
P	D-M9P-5	PNP

Specifications

Bore size [mm]	16	
Fluid	Air	
Action	Double acting	
Operating pressure [MPa]	0.1 to 0.7	
Repeatability [mm]	± 0.01	
Number of fingers	2	
Gripping force	External	32.7
	Internal	43.5
Opening/Closing stroke (Both sides) [mm]	10	
Weight [g]	720	

■ **Included parts:** Robot mounting flange, piping tube, cable fixture, accessory cable

Model Selection

Gripping force

● Indication of effective gripping force

The gripping force shown in the graphs below represents the gripping force of one finger when all fingers and attachments are in contact with the workpiece. **F** = One finger thrust

External gripping force

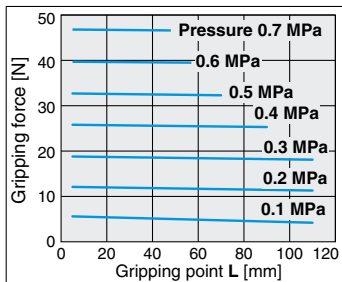
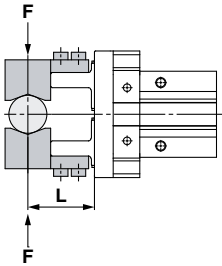

Internal gripping force

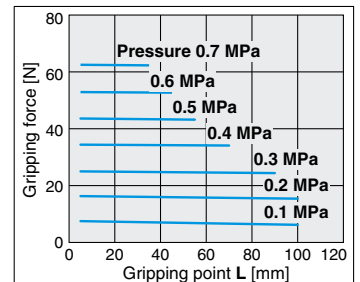
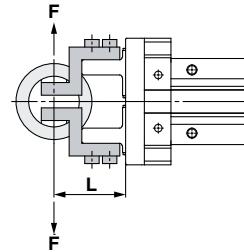

Gripping point

- The air gripper should be operated so that the workpiece gripping point "L" and the amount of overhang "H" stay within the range shown for each operating pressure given in the graphs below.
- If the workpiece gripping point goes beyond the range limits, this will have an adverse effect on the life of the air gripper.

External grip

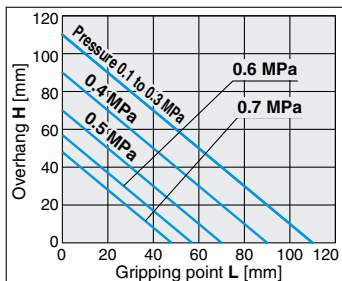
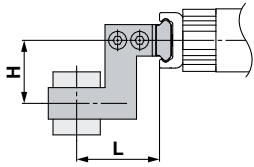

Internal grip

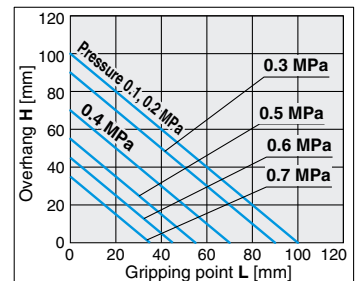
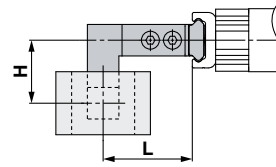

Dimensions

JMH22-16D-X7400B-HC10-□

Air gripper unit
for the MOTOMAN-HC10

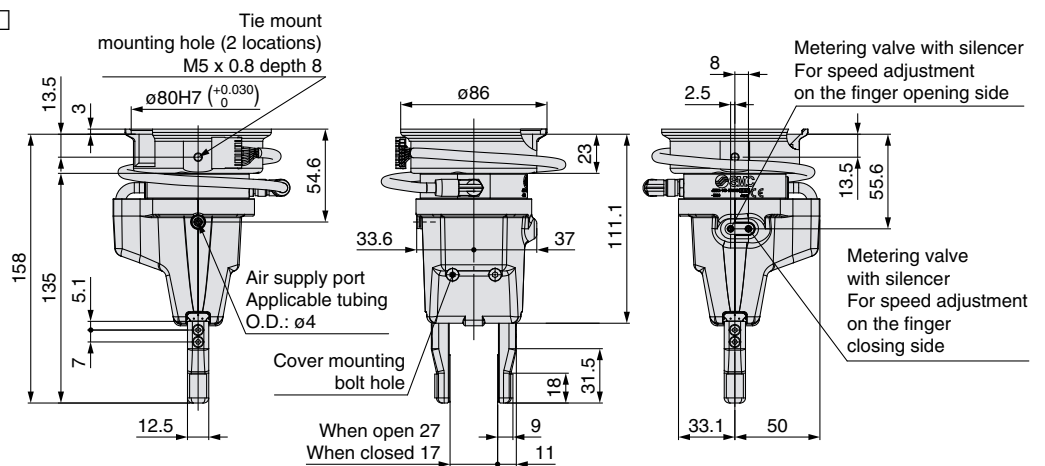

JMH22-16D-X7400B-HC10DT-□

Air gripper unit
for the MOTOMAN-HC10DT

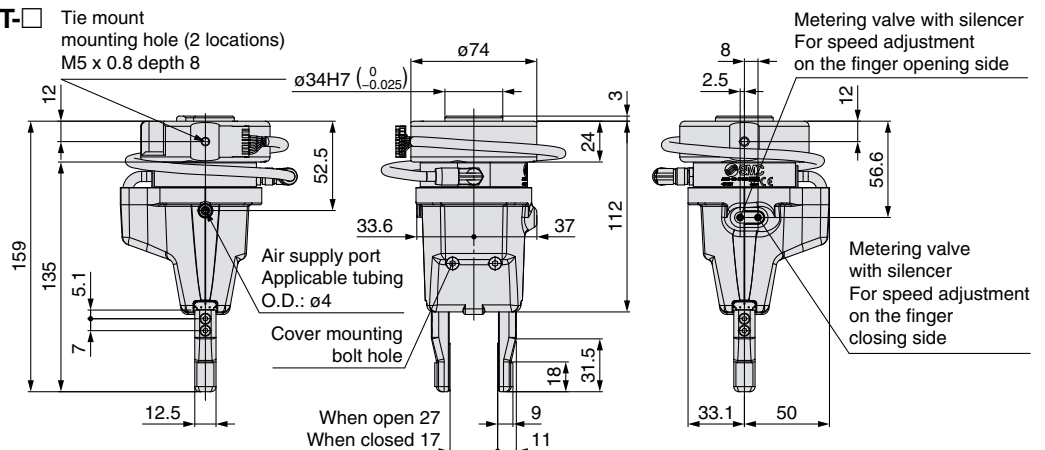



Air Gripper Unit

for Collaborative Robots

⚠ Safety Instructions Be sure to read the "Handling Precautions for SMC Products" (M-E03-3) and "Operation Manual" before use.