

Rotary Actuator

Vane Type

RoHS

Size: 10, 15, 20, 30, 40

New A **270° rotating angle specification** has been added.
Size: 10, 15, 40



Overall length

44% shorter

100 mm → **55.6 mm**

(Compared with the CDRB2□WU, Size 20)

Weight

48% lighter

222 g → **115 g**

(Compared with the CDRB2□WU, Size 20, Rotating angle 90°)

Features a compact body with a built-in

angle adjustment unit

and

auto switch unit

(Size: 20, 30, 40)

CDRBS20

CDRB2BWU20

Angle adjuster
10° (±5°)

With auto switch



55.6 mm

Angle adjustment unit

Auto switch unit



A rotation time of 0.5 s/90° is possible.

(CRB2: 0.3 s/90° * Excludes size 40)

Reduced by

44.4 mm



CRB Series



CAT.ES20-253C

Overall length

Size	CRB		CRB2		[mm]
					Reduction rate
10	46		58		21%
15	54.8		67		18%
20	55.6		100		44%
30	70		117.5		40%
40	84.2		137.2		39%
* Sizes 10 and 15 have been compared without an angle adjustment unit.					

Weight

Size	CRB	CRB2	Reduction rate
10	39	42	7%
15	62	68	9%
20	115	222	48%
30	216	387	44%
40	380	631	40%

Compared with the CRB2 (Rotating angle: 90° with an angle adjustment unit and an auto switch) (Sizes 10 and 15 have been compared without an angle adjustment unit.)

Piping, wiring, and angle adjustment can be performed on the same side for easier mounting.

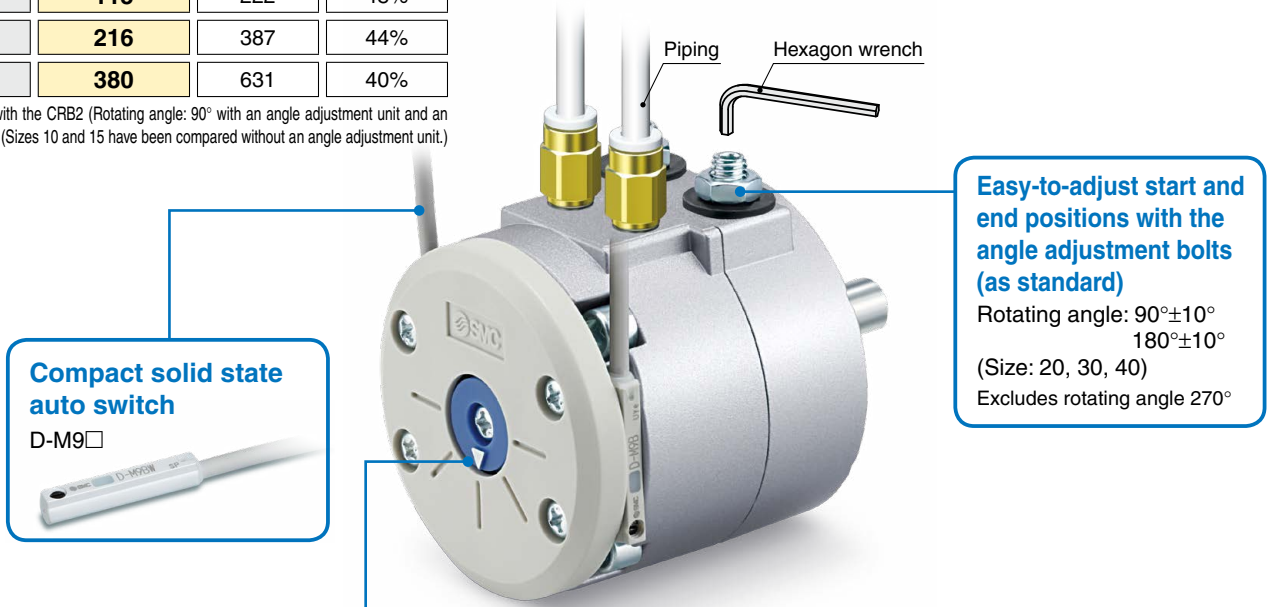

Compact solid state auto switch

D-M9□

Easy-to-adjust start and end positions with the angle adjustment bolts (as standard)

Rotating angle: 90°±10°
180°±10°
(Size: 20, 30, 40)
Excludes rotating angle 270°

The position of the chamfered portion of the shaft can be easily checked using the rotating angle indicator. (Only for the CDRB with auto switch)
Excludes rotating angle 270°

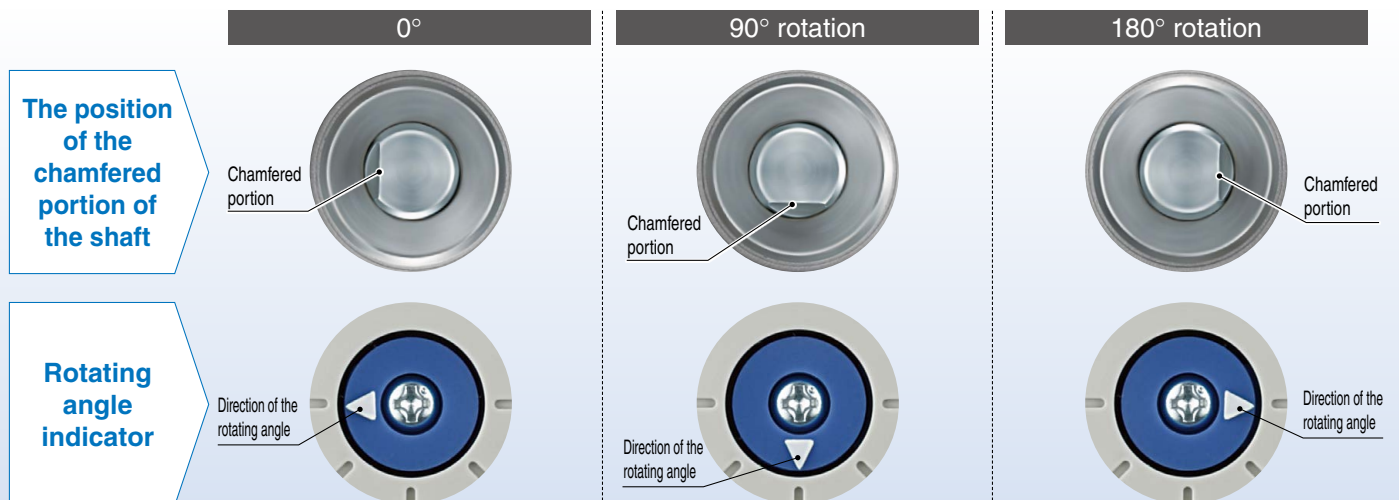

The position of the chamfered portion of the shaft

Rotating angle indicator

Shaft type variations

* If an auto switch is to be mounted, choose a single shaft (options ① and ⑤).

① Single shaft: CRBS

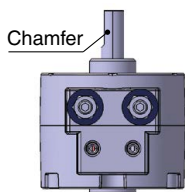

② Double shaft: CRBW

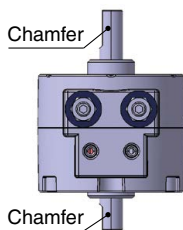

③ Double shaft: CRBJ

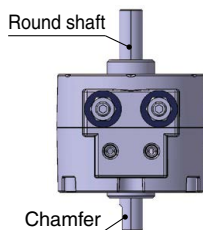

④ Double shaft: CRBK

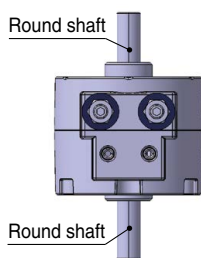

⑤ Single shaft: CRBT

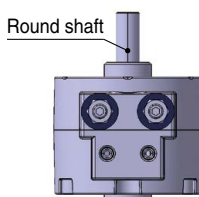

⑥ Double shaft: CRBY

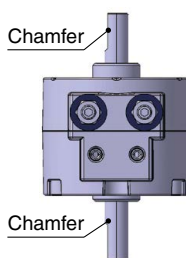

Interchangeable mounting

The mounting pitch and shaft configuration are the same as those for the CRB2.

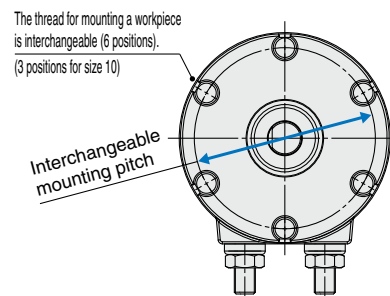

The shaft configuration is interchangeable.

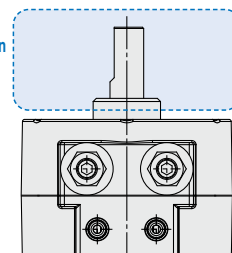

Mounting

Mounting type	Standard (Without auto switch) CRB	Standard (With auto switch) CDRB	With vertical auto switch unit CRB□-A	With angle adjustment unit CRB□-B	With vertical auto switch unit and angle adjustment unit CRB□-C
Body tapped					
Body through-hole					

* A flange mounting bracket assembly is available as an option. For details, refer to page 45.

Each of the units below for the CRB2 series can be mounted to the CRB series.

- The vertical auto switch unit and the angle adjustment unit are the same as those of the CRB2 series. Replacement of just the CRB body can be done during maintenance.
- Each of the units for the CRB2 series can be mounted to the CRB without an auto switch (CRBW).

CRB series: Body
(Without auto switch)

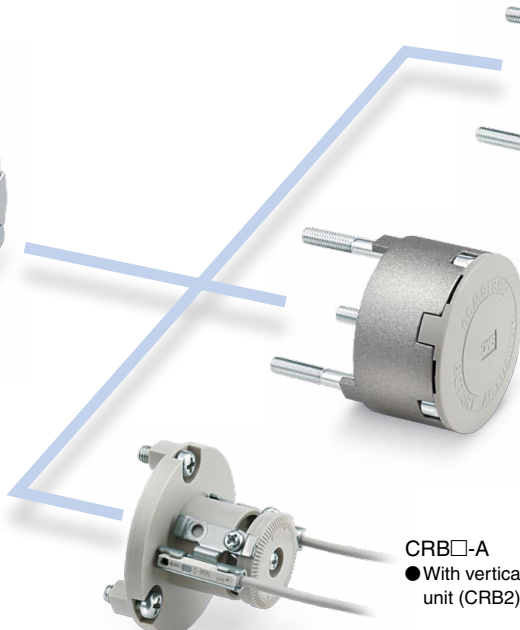

CRB□-C
● With vertical auto switch unit (CRB2) + angle adjustment unit (CRB2)*1

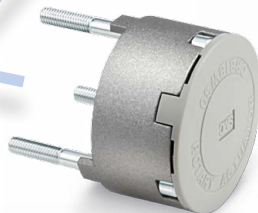

CRB□-B
● With angle adjustment unit (CRB2)

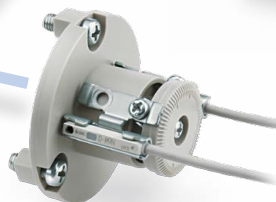





CRB□-A
● With vertical auto switch unit (CRB2)*1

*1 Applicable Auto Switches for the Vertical Auto Switch Unit

Size	Solid state auto switch	Reed auto switch
10	D-M9□(V) D-S99(V)/S9P(V) D-T99(V)	D-97/93A D-90/90A
15		
20	D-M9□(V) D-S79/S7P D-T79□	D-R73□ D-R80□
30		
40		

Refer to pages 35 and 47 to 50 for details on the angle adjustment method, auto switch mounting, and adjustment.

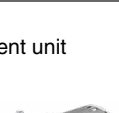
Series Variations

Model	Applicable auto switch	Vane type	Output shaft		Rotating angle	Size					Rotating angle adjustment range
			Single shaft	Double shaft		10	15	20	30	40	
CRB Standard (Without auto switch) 	—	Single vane	●	●	90°	●	●	●	●	●	90°±10° (One side ±5°) 180°±10° (One side ±5°) (Sizes 20, 30, and 40 only)
					180°	●	●	●	●	●	
					270°	●	●	●	●	●	
CDRB Standard (With auto switch) 	D-M9□	Single vane	●	—	90°	●	●	●	●	●	90°±10° (One side ±5°) 180°±10° (One side ±5°) (Sizes 20, 30, and 40 only)
					180°	●	●	●	●	●	
CRB□-A With vertical auto switch unit (CRB2) 	Refer to the applicable auto switches shown in the table above.*1	Single vane	●	—	90°	●	●	●	●	●	90°±10° (One side ±5°) 180°±10° (One side ±5°) (Sizes 20, 30, and 40 only)
					180°	●	●	●	●	●	
					270°	●	●	●	●	●	
CRB□-B With angle adjustment unit (CRB2) 	—	Single vane	●	—	90°	●	●	●	●	●	0 to 85° (90° specification) 0 to 175° (180° specification) (For sizes 10 and 15)
					180°	●	●	●	●	●	0 to 100° (90° specification) 0 to 190° (180° specification) (For sizes 20, 30, and 40)
					270°	●	●	●	●	●	0 to 230° (270° specification) (For sizes 10 and 40)
CRB□-C With vertical auto switch unit (CRB2) With angle adjustment unit (CRB2) 	Refer to the applicable auto switches shown in the table above.*1	Single vane	●	—	90°	●	●	●	●	●	0 to 85° (90° specification) 0 to 175° (180° specification) (For sizes 10 and 15)
					180°	●	●	●	●	●	0 to 100° (90° specification) 0 to 190° (180° specification) (For sizes 20, 30, and 40)
					270°	●	●	●	●	●	0 to 230° (270° specification) (For sizes 10 and 40)

CONTENTS

Vane Type Rotary Actuator *CRB Series*

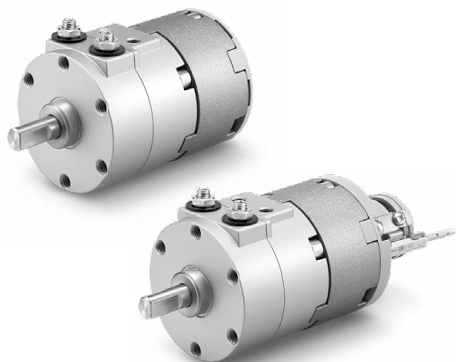

Model Selection p. 5

● **Vane Type Rotary Actuator
CRB Series**

How to Order p. 15
 Specifications p. 16
 Construction p. 18
 Dimensions p. 21

● **Vane Type Rotary Actuator
With Vertical Auto Switch Unit
CRB□-A Series**

How to Order p. 28
 Construction p. 29
 Dimensions p. 30

● **Vane Type Rotary Actuator
With Angle Adjustment Unit CRB□-B Series
With Vertical Auto Switch Unit and Angle Adjustment Unit CRB□-C Series**

How to Order p. 34
 Construction p. 36
 Dimensions p. 37

● **Component Unit** p. 46

● **Auto Switch Mounting** p. 47

● **Prior to Use** Auto Switch Connections and Examples p. 51

● **Specific Product Precautions** p. 52

● **Safety Instructions** Back cover

Model Selection

CRB

CRB□-A

CRB□-B/CRB□-C

Component Unit

Auto Switch Mounting

Rotary Actuator Model Selection

CONTENTS

1	Calculation of Moment of Inertia	p. 7
	● Equation Table of Moment of Inertia	p. 7
	● Calculation Example of Moment of Inertia	p. 8
	● Graph for Calculating the Moment of Inertia	p. 9
2	Calculation of Required Torque	p. 10
	● Load Type	p. 10
	● Effective Torque	p. 10
3	Confirmation of Rotation Time	p. 10
4	Calculation of Kinetic Energy	p. 11
	● Allowable Kinetic Energy and Rotation Time Adjustment Range	p. 11
	● Moment of Inertia and Rotation Time	p. 12
5	Confirmation of Allowable Load	p. 12
6	Calculation of Air Consumption and Required Air Flow Capacity	p. 13
	● Inner Volume and Air Consumption	p. 13
	● Air Consumption Calculation Graph	p. 14

Rotary Actuator Model Selection

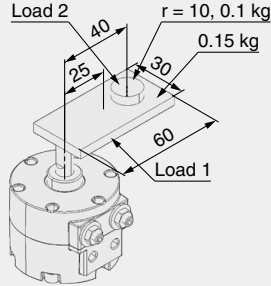
Selection Procedures	Note	Selection Example
<p>◆ List of Operating Conditions</p> <ul style="list-style-type: none"> Initially selected models Operating pressure [MPa] Mounting orientation Load type <ul style="list-style-type: none"> Static load Resistance load Inertial load Load dimensions [m] Load mass [kg] Rotation time [s] Rotating angle [rad] 	<p>The unit for the rotating angle is radian. $180^\circ = \pi \text{ rad}$ $90^\circ = \pi/2 \text{ rad}$</p>	 <p>Initially selected model: CRBS30-180 Operating pressure: 0.4 MPa Mounting orientation: Vertical Load type: Inertial load Rotation time: $t = 0.6 \text{ s}$ Rotating angle: $\theta = \pi \text{ rad} (180^\circ)$</p>
1 Calculation of Moment of Inertia		
<p>Calculate the inertial moment of load.</p>	<p>Loads are generated from multiple parts. The inertial moment of each load is calculated, and then totaled.</p>	<p>Inertial moment of load 1: I_1 $I_1 = 0.15 \times \frac{0.06^2 + 0.03^2}{12} + 0.15 \times 0.025^2 = 0.00015$ Inertial moment of load 2: I_2 $I_2 = 0.1 \times \frac{0.01^2}{2} + 0.1 \times 0.04^2 = 0.000165$ Total inertial moment: I $I = I_1 + I_2 = 0.000315 \text{ [kg}\cdot\text{m}^2]$</p>
2 Calculation of Required Torque		
<p>Calculate the required torque for each load type and confirm whether the values fall in the effective torque range.</p> <ul style="list-style-type: none"> Static load (T_s) Required torque $T = T_s$ Resistance load (T_f) Required torque $T = T_f \times (3 \text{ to } 5)$ Inertial load (T_a) Required torque $T = T_a \times 10$ 	<p>When the resistance load is rotated, the required torque calculated from the inertial load must be added.</p> <p>Required torque $T = T_f \times (3 \text{ to } 5) + T_a \times 10$</p>	<p>Inertial load: T_a $T_a = I \cdot \dot{\omega}$ $\dot{\omega} = \frac{2\theta}{t^2} \text{ [rad/s}^2]$ Required torque: T $T = T_a \times 10$ $= 0.000315 \times \frac{2 \times \pi}{0.6^2} \times 10 = 0.055 \text{ [N}\cdot\text{m}]$ $0.055 \text{ N}\cdot\text{m} < \text{Effective torque OK}$</p>
3 Confirmation of Rotation Time		
<p>Confirm whether the time falls in the rotation time adjustment range.</p>	<p>Consider the time after converted in the time per 90°. $(0.6 \text{ s}/180^\circ \text{ is converted in } 0.3 \text{ s}/90^\circ.)$</p>	<p>$0.04 \leq t \leq 0.5$ $t = 0.3 \text{ s}/90^\circ \text{ OK}$</p>
4 Calculation of Kinetic Energy		
<p>Calculate the kinetic energy of the load and confirm whether the energy is below the allowable range.</p>	<p>If the energy exceeds the allowable range, a suitable cushioning mechanism such as a shock absorber must be externally installed.</p>	<p>Kinetic energy: E $E = \frac{1}{2} \cdot I \cdot \omega^2$ $\omega = \frac{2 \cdot \theta}{t}$ $E = \frac{1}{2} \times 0.000315 \times \left(\frac{2 \times \pi}{0.6}\right)^2 = 0.01725 \text{ [J]}$ $0.01725 \text{ [J]} < \text{Allowable energy OK}$</p>
5 Confirmation of Allowable Load		
<p>Confirm whether the load applied to the product is within the allowable range.</p>	<p>If the load exceeds the allowable range, a bearing or similar must be externally installed.</p>	<p>Thrust load: M $0.15 \times 9.8 + 0.1 \times 9.8$ $= 2.45 \text{ [N]}$ $2.45 \text{ [N]} < \text{Allowable thrust load OK}$</p>
6 Calculation of Air Consumption and Required Air Flow Capacity		
<p>Air consumption and required air flow capacity are calculated when necessary.</p>		

Model Selection

CRB

CRB□-A

CRB□-B/CRB□-C

Component Unit

Auto Switch Mounting

Rotary Actuator Model Selection

1 Calculation of Moment of Inertia

The moment of inertia is a value indicating the inertia of a rotating body, and expresses the degree to which the body is difficult to rotate, or difficult to stop.

It is necessary to know the moment of inertia of the load in order to determine the value of required torque or kinetic energy when selecting a rotary actuator.

Moving the load with the actuator creates kinetic energy in the load. When stopping the moving load, it is necessary to absorb the kinetic energy of the load with a stopper or a shock absorber.

The kinetic energy of the load can be calculated using the formulas shown in **Fig.1** (for linear motion) and **Fig.2** (for rotation motion).

In the case of the kinetic energy for linear motion, the formula (1) shows that when the velocity **V** is constant, it is proportional to the mass **m**. In the case of rotation motion, the formula (2) shows that when the angular velocity ω is constant, it is proportional to the moment of inertia.

Linear motion

Fig. 1 Linear motion

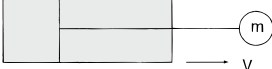

$$E = \frac{1}{2} \cdot m \cdot v^2 \dots\dots\dots (1)$$

E : Kinetic energy
m : Load mass
v : Velocity

Rotation motion

Fig. 2 Rotation motion

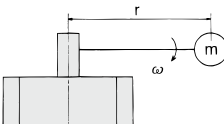

$$E = \frac{1}{2} \cdot I \cdot \omega^2 = \frac{1}{2} \cdot m \cdot r^2 \cdot \omega^2 \dots\dots\dots (2)$$

E : Kinetic energy
I : Moment of inertia (= $m \cdot r^2$)
 ω : Angular velocity
m : Mass
r : Radius of rotation

As the moment of inertia is proportional to the squares of the mass and the radius of rotation, even when the load mass is the same, the moment of inertia will be squared as the radius of rotation grows bigger. This will create greater kinetic energy, which may result in damage to the product.

When there is rotation motion, product selection should be based not on the load mass of the load, but on the moment of inertia.

Moment of Inertia Formula

The basic formula for finding a moment of inertia is shown below.

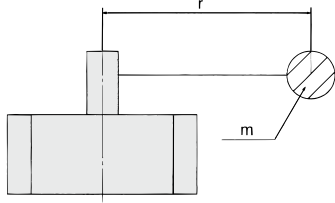

I = m · r²

m : Mass
r : Radius of rotation

This formula represents the moment of inertia for the shaft with mass **m**, which is located at distance **r** from the shaft.

For actual loads, the values of the moment of inertia are calculated depending on configurations, as shown below.

- ⇒ p. 8 Calculation example of moment of inertia
- ⇒ p. 9 Graph for calculating the moment of inertia

Equation Table of Moment of Inertia

- 1. Thin shaft**
 Position of rotational axis: Perpendicular to the shaft through the center of gravity

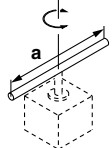
$$I = m \cdot \frac{a^2}{12}$$

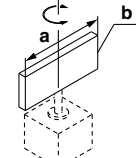
- 2. Thin rectangular plate**
 Position of rotational axis: Parallel to side b and through the center of gravity

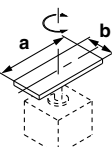
$$I = m \cdot \frac{a^2}{12}$$

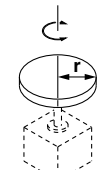
- 3. Thin rectangular plate (Including rectangular parallelepiped)**
 Position of rotational axis: Perpendicular to the plate through the center of gravity

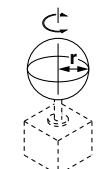
$$I = m \cdot \frac{a^2 + b^2}{12}$$

- 4. Round plate (Including column)**
 Position of rotational axis: Through the center axis

$$I = m \cdot \frac{r^2}{2}$$

- 5. Solid sphere**
 Position of rotational axis: Through the center of diameter

$$I = m \cdot \frac{2r^2}{5}$$

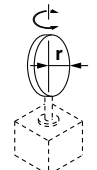
I: Moment of inertia m: Load mass

- 6. Thin round plate**
 Position of rotational axis: Through the center of diameter

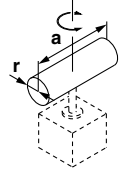
$$I = m \cdot \frac{r^2}{4}$$

- 7. Cylinder**
 Position of rotational axis: Through the center of diameter and gravity

$$I = m \cdot \frac{3r^2 + a^2}{12}$$

- 8. When the rotational axis and load center of gravity are not consistent**

$$I = K + m \cdot L^2$$

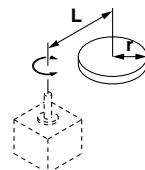
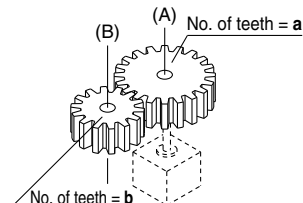
K: Moment of inertia around the load center of gravity

4. Round plate $K = m \cdot \frac{r^2}{2}$

- 9. Gear transmission**
 1. Find the moment of inertia I_B for the rotation of shaft (B).
 2. I_B is converted to the moment of inertia I_A for the rotation of the shaft (A).
$$I_A = \left(\frac{a}{b}\right)^2 \cdot I_B$$

● Calculation Example of Moment of Inertia

■ If the shaft is located at a desired point of the load:

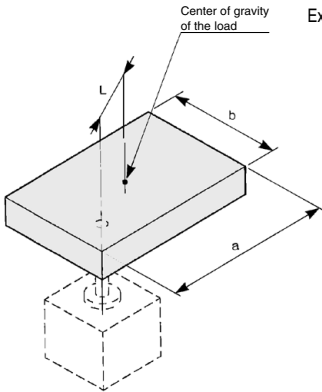

Example: ① If the load is the thin rectangular plate: Find the center of gravity of the load as I_1 , a provisional shaft.

$$I_1 = m \cdot \frac{a^2 + b^2}{12}$$

② Find the actual moment of inertia I_2 around the shaft, with the premise that the mass of the load itself is concentrated in the load's center of gravity point.

$$I_2 = m \cdot L^2$$

③ Find the actual moment of inertia I .

$$I = I_1 + I_2$$

(m : Load mass
 L : Distance from the shaft to the load's center of gravity)

Calculation Example

$a = 0.2 \text{ m}$, $b = 0.1 \text{ m}$, $L = 0.05 \text{ m}$, $m = 1.5 \text{ kg}$

$$I_1 = 1.5 \times \frac{0.2^2 + 0.1^2}{12} = 6.25 \times 10^{-3} \quad \text{kg} \cdot \text{m}^2$$

$$I_2 = 1.5 \times 0.05^2 = 3.75 \times 10^{-3} \quad \text{kg} \cdot \text{m}^2$$

$$I = (6.25 + 3.75) \times 10^{-3} = 0.01 \quad \text{kg} \cdot \text{m}^2$$

■ If a lever is attached to the shaft and a cylinder and a gripper are mounted to the tip of the lever:

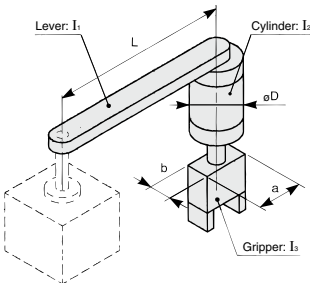

Example: ① Find the lever's moment of inertia:

$$I_1 = m_1 \cdot \frac{L^2}{3}$$

② Find the cylinder's moment of inertia:

$$I_2 = m_2 \cdot \frac{(D/2)^2}{2} + m_2 \cdot L^2$$

③ Find the gripper's moment of inertia:

$$I_3 = m_3 \cdot \frac{a^2 + b^2}{12} + m_3 \cdot L^2$$

④ Find the actual moment of inertia:

$$I = I_1 + I_2 + I_3$$

(m_1 : Mass of lever
 m_2 : Mass of cylinder
 m_3 : Mass of gripper)

Calculation Example

$L = 0.2 \text{ m}$, $\phi D = 0.06 \text{ m}$, $a = 0.06 \text{ m}$, $b = 0.03 \text{ m}$

$m_1 = 0.5 \text{ kg}$, $m_2 = 0.4 \text{ kg}$, $m_3 = 0.2 \text{ kg}$

$$I_1 = 0.5 \times \frac{0.2^2}{3} = 0.67 \times 10^{-2} \quad \text{kg} \cdot \text{m}^2$$

$$I_2 = 0.4 \times \frac{(0.06/2)^2}{2} + 0.4 \times 0.2^2 = 1.62 \times 10^{-2} \quad \text{kg} \cdot \text{m}^2$$

$$I_3 = 0.2 \times \frac{0.06^2 + 0.03^2}{12} + 0.2 \times 0.2^2 = 0.81 \times 10^{-2} \quad \text{kg} \cdot \text{m}^2$$

$$I = (0.67 + 1.62 + 0.81) \times 10^{-2} = 3.1 \times 10^{-2} \quad \text{kg} \cdot \text{m}^2$$

■ If the load is divided into multiple loads:

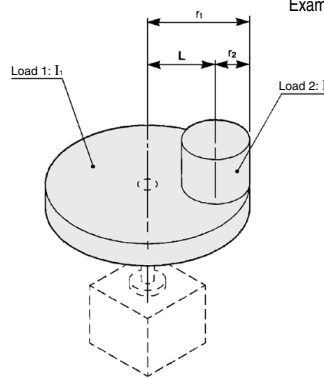

Example: ① If the load is divided into the 2 cylinders: [The center of gravity of load 1 matches the shaft] [The center of gravity of load 2 differs from the shaft] Find the moment of inertia of load 1:

$$I_1 = m_1 \cdot \frac{r_1^2}{2}$$

② Find the moment of inertia of load 2:

$$I_2 = m_2 \cdot \frac{r_2^2}{2} + m_2 \cdot L^2$$

③ Find the actual moment of inertia I :

$$I = I_1 + I_2$$

(m_1, m_2 : Mass of loads 1 and 2
 r_1, r_2 : Radius of loads 1 and 2
 L : Distance from the shaft to the center of gravity of load 2)

Calculation Example

$m_1 = 2.5 \text{ kg}$, $m_2 = 0.5 \text{ kg}$, $r_1 = 0.1 \text{ m}$, $r_2 = 0.02 \text{ m}$, $L = 0.08 \text{ m}$

$$I_1 = 2.5 \times \frac{0.1^2}{2} = 1.25 \times 10^{-2} \quad \text{kg} \cdot \text{m}^2$$

$$I_2 = 0.5 \times \frac{0.02^2}{2} + 0.5 \times 0.08^2 = 0.33 \times 10^{-2} \quad \text{kg} \cdot \text{m}^2$$

$$I = (1.25 + 0.33) \times 10^{-2} = 1.58 \times 10^{-2} \quad \text{kg} \cdot \text{m}^2$$

■ If a load is rotated through the gears:

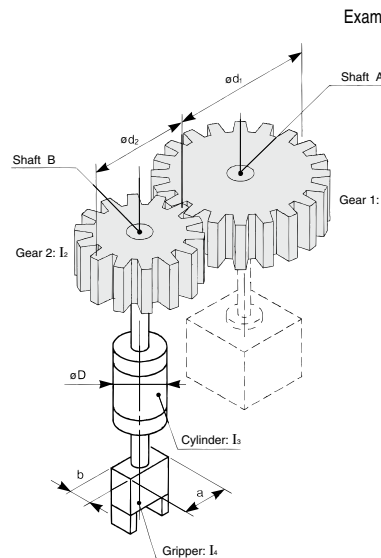

Example: ① Find the moment of inertia I_1 around shaft A:

$$I_1 = m_1 \cdot \frac{(d_1/2)^2}{2}$$

② Find moment of inertias I_2 , I_3 , and I_4 around shaft B:

$$I_2 = m_2 \cdot \frac{(d_2/2)^2}{2}$$

$$I_3 = m_3 \cdot \frac{(D/2)^2}{2}$$

$$I_4 = m_4 \cdot \frac{a^2 + b^2}{12}$$

$$I_B = I_2 + I_3 + I_4$$

③ Replace the moment of inertia I_B around shaft B with the moment of inertia I_A around shaft A.

$$I_A = (A/B)^2 \cdot I_B$$

[A/B: Ratio of the number of teeth]

④ Find the actual moment of inertia:

$$I = I_1 + I_A$$

(m_1 : Mass of gear 1
 m_2 : Mass of gear 2
 m_3 : Mass of cylinder
 m_4 : Mass of gripper)

Calculation Example

$d_1 = 0.1 \text{ m}$, $d_2 = 0.05 \text{ m}$, $D = 0.04 \text{ m}$, $a = 0.04 \text{ m}$, $b = 0.02 \text{ m}$

$m_1 = 1 \text{ kg}$, $m_2 = 0.4 \text{ kg}$, $m_3 = 0.5 \text{ kg}$, $m_4 = 0.2 \text{ kg}$, Ratio of the number of teeth = 2

$$I_1 = 1 \times \frac{(0.1/2)^2}{2} = 1.25 \times 10^{-3} \text{ kg} \cdot \text{m}^2$$

$$I_2 = 0.4 \times \frac{(0.05/2)^2}{2} = 0.13 \times 10^{-3} \text{ kg} \cdot \text{m}^2$$

$$I_3 = 0.5 \times \frac{(0.04/2)^2}{2} = 0.1 \times 10^{-3} \text{ kg} \cdot \text{m}^2$$

$$I_4 = 0.2 \times \frac{0.04^2 + 0.02^2}{12} = 0.03 \times 10^{-3} \text{ kg} \cdot \text{m}^2$$

$$I_B = (0.13 + 0.1 + 0.03) \times 10^{-3} = 0.26 \times 10^{-3} \text{ kg} \cdot \text{m}^2$$

$$I_A = 2^2 \times 0.26 \times 10^{-3} = 1.04 \times 10^{-3} \text{ kg} \cdot \text{m}^2$$

$$I = (1.25 + 1.04) \times 10^{-3} = 2.29 \times 10^{-3} \text{ kg} \cdot \text{m}^2$$

Rotary Actuator Model Selection

● Graph for Calculating the Moment of Inertia

Load Shapes

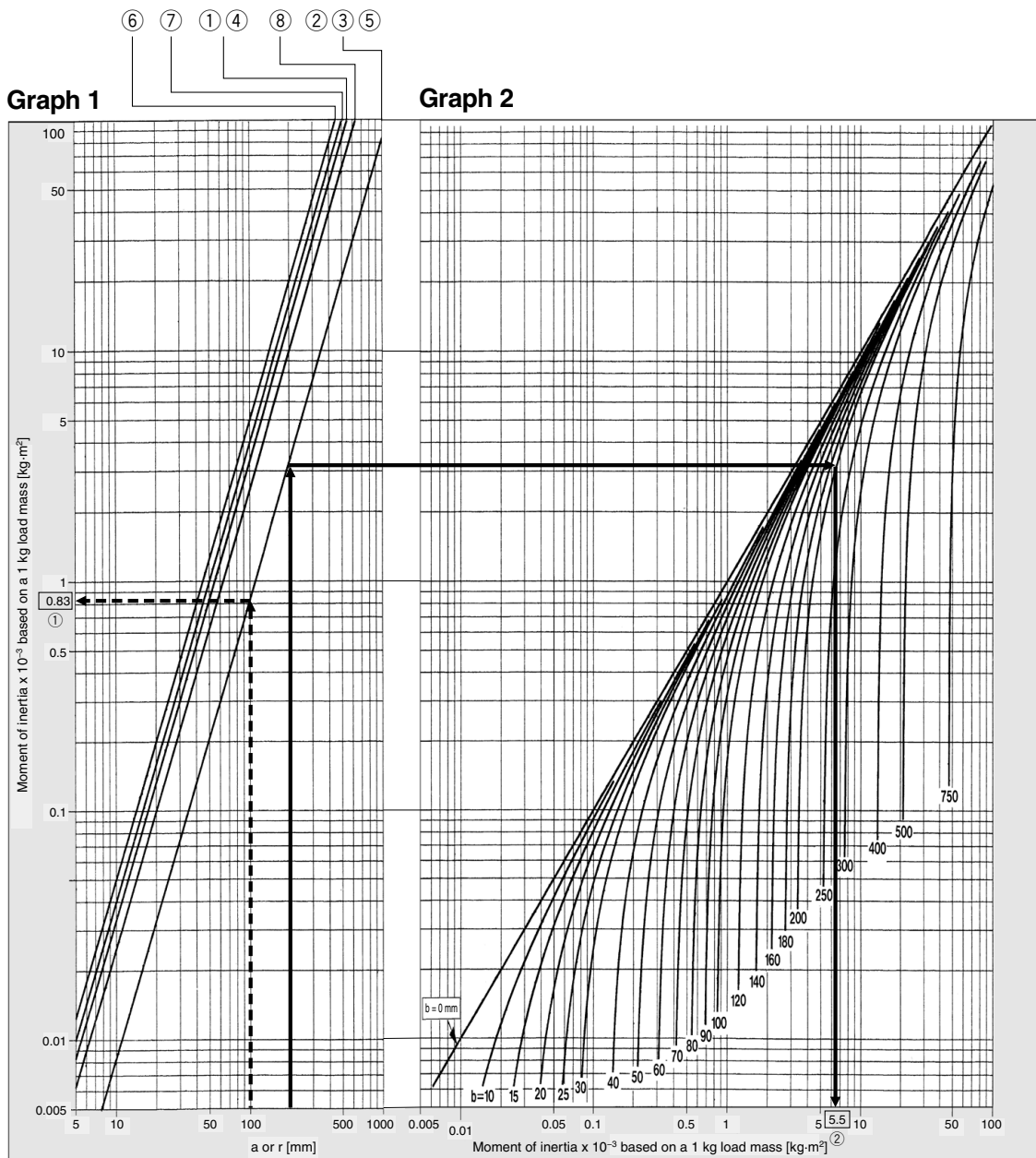
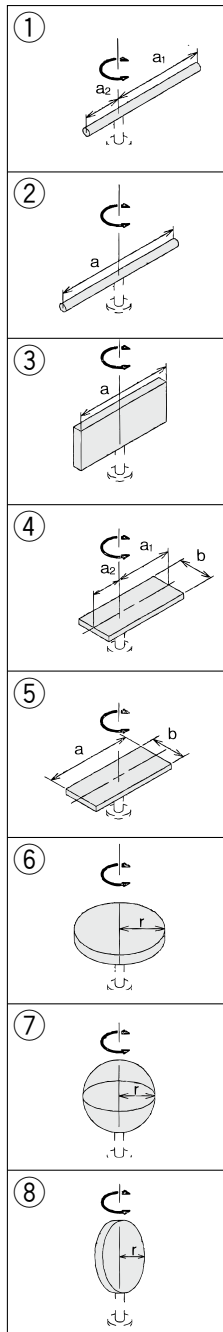

1. How to read the graph: Only when the dimension of the load is "a" or "r"

[Example] When the load shape is ②, $a = 100$ mm, and the load mass is 0.1 kg

In graph 1, the point at which the vertical line of $a = 100$ mm and the line of the load shape ② intersect indicates that the moment of inertia of the 1 kg mass is 0.83×10^{-3} kg·m².

Since the load mass is 0.1 kg, the actual moment of inertia is $0.83 \times 10^{-3} \times 0.1 = 0.083 \times 10^{-3}$ kg·m²

(Note: If "a" is divided into "a₁a₂", the moment of inertia can be found by calculating them separately.)

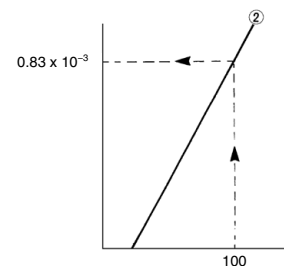

2. How to read the graph: When the dimension of the load contains both "a" and "b"

[Example] When the load shape is ⑤, $a = 200$ mm, $b = 200$ mm, and the load mass is 0.5 kg

In graph 1, find the point at which the vertical line of $a = 200$ mm and the line of the load shape ⑤ intersect. Move this intersection point to graph 2, and the point at which it intersects with the curve of $b = 200$ mm indicates that the moment of inertia of the 1 kg mass is 5.5×10^{-3} kg·m².

Since the load mass is 0.5 kg, the actual moment of inertia is $5.5 \times 10^{-3} \times 0.5 = 2.75 \times 10^{-3}$ kg·m²

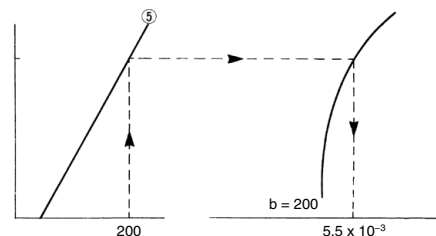

2 Calculation of Required Torque

● Load Type

The calculation method of required torque varies depending on the load type. Find the required torque referring to the table below.

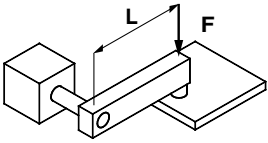
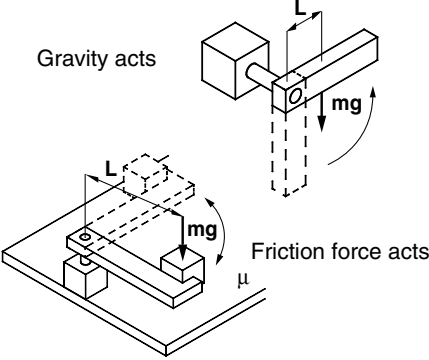
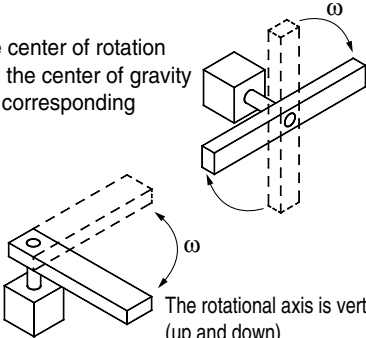
Load type		
Static load: T_s	Resistance load: T_f	Inertial load: T_a
When the pressing force is necessary (clamp, etc.)	When friction force or gravity is applied to the rotation direction	When the load with inertia is rotated
		
$T_s = F \cdot L$ T_s : Static load [N·m] F : Clamp force [N] L : Distance from the center of rotation to clamp [m]	When gravity acts to the rotation direction $T_f = m \cdot g \cdot L$ T_f : Resistance load [N·m] m : Load mass [kg] g : Gravitational acceleration 9.8 [m/s ²] L : Distance from the center of rotation to the gravity or friction force acting point [m] μ : Coefficient of friction When friction force acts to the rotation direction $T_f = \mu \cdot m \cdot g \cdot L$	$T_a = I \cdot \dot{\omega} = I \cdot \frac{2\theta}{t^2}$ T_a : Inertial load [N·m] I : Moment of inertia [kg·m ²] $\dot{\omega}$: Angular acceleration [rad/s ²] θ : Rotating angle [rad] t : Rotation time [s]
Required torque $T = T_s$	Required torque $T = T_f \times (3 \text{ to } 5)^{*1}$	Required torque $T = T_a \times 10^{*1}$
<ul style="list-style-type: none"> Resistance loads → Gravity or friction applies in the rotation direction. Example 1) The axis of rotation is in a horizontal (lateral) direction, and the center of rotation and center of gravity of the load are not the same. Example 2) The load slips against the floor while rotating. * The required torque equals the total of the resistance load and inertial load. $T = T_f \times (3 \text{ to } 5) + T_a \times 10$ Non-resistance loads → Gravity or friction does not apply in the rotation direction. Example 1) The axis of rotation is in a perpendicular (vertical) direction. Example 2) The axis of rotation is in a horizontal (lateral) direction, and the center of rotation and center of gravity of the load are the same. * The required torque equals the inertial load only. $T = T_a \times 10$ <p>*1 In order to adjust the velocity, it is necessary to have a margin of adjustment for T_f and T_a.</p>		

● Effective Torque

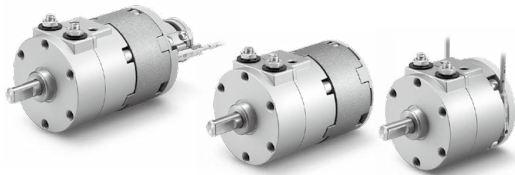

Size	Operating pressure [MPa]								
	0.2	0.3	0.4	0.5	0.6	0.7	0.8	0.9	1.0
10	0.03	0.06	0.09	0.12	0.15	0.18	—	—	—
15	0.10	0.17	0.24	0.32	0.39	0.46	—	—	—
20	0.23	0.39	0.54	0.70	0.84	0.99	—	—	—
30	0.62	1.04	1.39	1.83	2.19	2.58	3.03	3.40	3.73
40	1.21	2.07	2.90	3.73	4.55	5.38	6.20	7.03	7.86

3 Confirmation of Rotation Time

Rotation time adjustment range is specified for each product for stable operation. Set the rotation time within the rotation time specified below.

Model	Rotation time adjustment range [⁹ /90°]													
	0.02	0.03	0.05	0.1	0.2	0.3	0.5	1	2	3	4	5	10	20
CRB	Size: 10, 15, 20													
	Size: 30													
	Size: 40													

If the product is used in a low speed range which is outside the adjustment range, it may cause the stick-slip phenomenon, or the product to stick or stop.

Rotary Actuator Model Selection

4 Calculation of Kinetic Energy

Kinetic energy is generated when the load rotates. Kinetic energy applies on the product at the operating end as inertial force, and may cause the product to damage. In order to avoid this, the value of allowable kinetic energy is determined for each product. Find the kinetic energy of the load, and verify that it is within the allowable range for the product in use.

Kinetic Energy

Use the following formula to calculate the kinetic energy of the load.

$$E = \frac{1}{2} \cdot I \cdot \omega^2$$

E: Kinetic energy [J]
I: Moment of inertia [kg·m²]
ω: Angular velocity [rad/s]

⇒Below Allowable kinetic energy and rotation time adjustment range
⇒p. 12 Moment of inertia and rotation time

To find the rotation time when kinetic energy is within the allowable range for the product, use the following formula.

When the angular velocity is $\omega = \frac{2\theta}{t}$

$$t \geq \sqrt{\frac{2 \cdot I \cdot \theta^2}{E}}$$

t: Rotation time [s]
I: Moment of inertia [kg·m²]
θ: Rotating angle [rad]
E: Allowable kinetic energy [J]

Angular Velocity

$$\omega = \frac{2\theta}{t}$$

ω: Angular velocity [rad/s]
θ: Rotating angle [rad]
t: Rotation time [s]

● Allowable Kinetic Energy and Rotation Time Adjustment Range

Allowable Kinetic Energy and Rotation Time Adjustment Range

Size	Allowable kinetic energy [J]	Adjustable range of rotation time safe in operation [°/90°]
10	0.00015	0.03 to 0.5
15	0.001	
20	0.003	
30	0.020	0.04 to 0.5
40	0.040	0.07 to 0.5

Calculation Example

Load form: Round rod

Length of a₁ part : 0.12 m Rotating angle: 90°

Length of a₂ part : 0.04 m Rotation time : 0.9 ^s/_{90°}

Mass of a₁ part (= m₁): 0.09 kg

Mass of a₂ part (= m₂): 0.03 kg

$$I = m_1 \cdot \frac{a_1^2}{3} + m_2 \cdot \frac{a_2^2}{3}$$

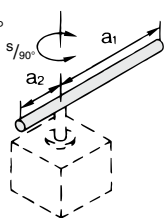

(Step 1) Find the angular velocity ω.

$$\omega = \frac{2\theta}{t} = \frac{2}{0.9} \left(\frac{\pi}{2} \right) = 3.489 \text{ rad/s}$$

(Step 2) Find the moment of inertia I.

$$I = \frac{m_1 \cdot a_1^2}{3} + \frac{m_2 \cdot a_2^2}{3} = \frac{0.09 \times 0.12^2}{3} + \frac{0.03 \times 0.04^2}{3} = 4.48 \times 10^{-4} \text{ kg}\cdot\text{m}^2$$

(Step 3) Find the kinetic energy E.

$$E = \frac{1}{2} \cdot I \cdot \omega^2 = \frac{1}{2} \times 4.48 \times 10^{-4} \times 3.489^2 = 0.00273 \text{ J}$$

Calculation Example

If the model to be used has been determined, find the threshold rotation time in which the rotary actuator can be used in accordance with the allowable kinetic energy of that model.

Model used : CRB30

Allowable kinetic energy: 0.02 J (Refer to the table above.)

Load form : Refer to the figure below.

Rotating angle : 90°

$$I = m_1 \cdot \frac{a_1^2}{3} + m_2 \cdot a_2^2 + m_2 \cdot \frac{2r^2}{5}$$

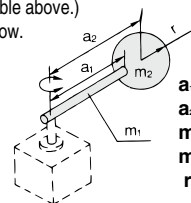

a₁: 0.1 m
a₂: 0.12 m
m₁: 0.02 kg
m₂: 0.02 kg
r: 0.03 m

(Step 1) Find the moment of inertia.

$$I = \frac{m_1 \cdot a_1^2}{3} + m_2 \cdot a_2^2 + \frac{m_2 \cdot 2r^2}{5} = \frac{0.02 \times 0.1^2}{3} + 0.02 \times 0.12^2 + \frac{0.02 \times 2 \times 0.03^2}{5} = 3.6 \times 10^{-4} \text{ kg}\cdot\text{m}^2$$

(Step 2) Find the rotation time.

$$t \geq \sqrt{\frac{2 \cdot I \cdot \theta^2}{E}} = \sqrt{\frac{2 \times 3.6 \times 10^{-4} \times (\pi/2)^2}{0.02}} = 0.30 \text{ s}$$

It is therefore evident that there will be no problem if it is used with a rotation time of less than 0.30 s. However, according to the table above, the maximum value of rotation time for stable operation is 0.5 s. Thus, the rotation time should be within the range of 0.30 ≤ t ≤ 0.50.

● Moment of Inertia and Rotation Time

How to read the graph

Example 1) When there are constraints on the moment of inertia of the load and the rotation time:

We can see from graph 3 that to operate the load at a 1×10^{-4} kg·m² moment of inertia and at the rotation time setting of $0.3 \text{ s}/90^\circ$, the model will be CRB□30.

Example 2) When there are constraints on the moment of inertia of the load but not the rotation time:

We can see from graph 3 that to operate the load at a 1×10^{-5} kg·m² moment of inertia:

(CRB15 will be 0.22 to $0.5 \text{ s}/90^\circ$)
(CRB20 will be 0.13 to $0.5 \text{ s}/90^\circ$)

[Remarks] As for the rotation times in graph 3, the lines in the graph indicate the adjustable speed ranges. However, if the speed is adjusted toward the low-speed end beyond the range of the line, the actuator may stick, or, in the case of the vane type, the operation may stop.

Graph 3 Size: 10 to 40

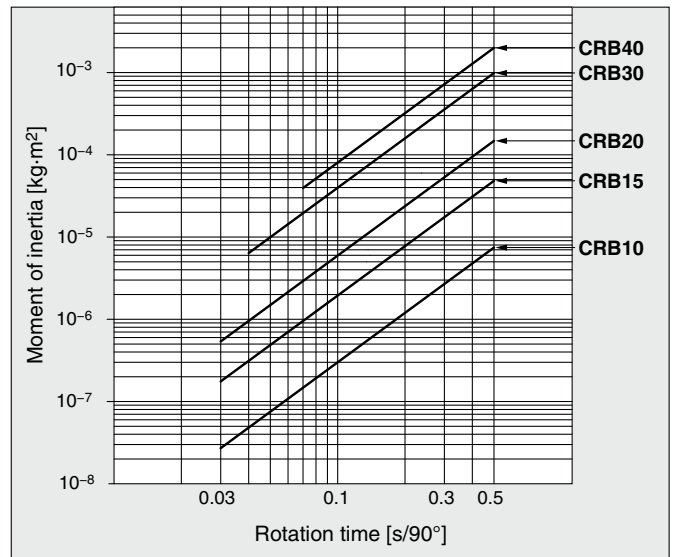

5 Confirmation of Allowable Load

Provided that a dynamic load is not generated, a load in the axial direction can be applied up to the value that is indicated in the table below. However, applications in which the load is applied directly to the shaft should be avoided as much as possible.

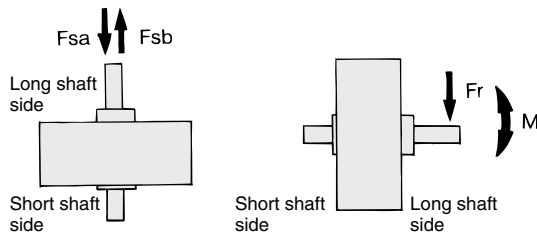

Vane Type (Single)

Series	Size	Load direction			
		Fsa [N]	Fsb [N]	Fr [N]	M [N·m]
CRB	10	9.8	9.8	14.7	0.13
	15	9.8	9.8	14.7	0.17
	20	19.6	19.6	24.5	0.33
	30	24.5	24.5	29.4	0.42
	40	40	40	60	1.02

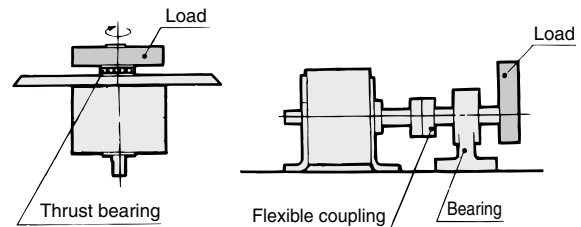

Rotary Actuator Model Selection

6 Calculation of Air Consumption and Required Air Flow Capacity

Air consumption is the volume of air which is expended by the rotary actuator's reciprocal operation inside the actuator and in the piping between the actuator and the switching valve, etc. This is necessary for selection of a compressor and for calculation of its running cost. Required air volume is the air volume necessary to make a rotary actuator operate at a required speed. It requires calculation when selecting the upstream piping diameter from the switching valve and air line equipment.

* To facilitate your calculation, the table below provide the air consumption volume (Q_{CR}) that is required each time an individual rotary actuator makes a reciprocal movement.

① Air consumption volume

Formula

Regarding QCR: With vane type, use formula (1) because the inner volume varies when ports A and B are pressurized.

$$Q_{CR} = (V_A + V_B) \times \left(\frac{P+0.1}{0.1} \right) \times 10^{-3} \dots (1)$$

$$Q_{CP} = 2 \times a \times L \times \left(\frac{P}{0.1} \right) \times 10^{-6} \dots (2)$$

$$Q_C = Q_{CR} + Q_{CP} \dots (3)$$

Q_{CR} = Amount of air consumption of rotary actuator [L (ANR)]

Q_{CP} = Amount of air consumption of tube or piping [L (ANR)]

V_A = Inner volume of the rotary actuator (when pressurized from A port) [cm³]

V_B = Inner volume of the rotary actuator (when pressurized from B port) [cm³]

P = Operating pressure [MPa]

L = Length of piping [mm]

a = Inner sectional area of piping [mm²]

Q_C = Amount of air consumption required for one cycle of the rotary actuator [L (ANR)]

To select a compressor, it is important to select one that has plenty of margin to accommodate the total air volume that is consumed by the pneumatic actuators that are located downstream. The total air consumption volume is affected by the leakage in the tube, the consumption in the drain valves and pilot valves, as well as by the reduction in air volume due to reduced temperature.

Formula

$$Q_{C2} = Q_C \times n \times \text{No. of actuators} \times \text{Safety factor} \dots (4)$$

Q_{C2} = Amount of air from a compressor [L/min (ANR)]

n = Actuator reciprocations per minute

Safety factor: From 1.5

② Required air flow capacity

Formula

$$Q_r = \left\{ V_B \times \left(\frac{P+0.1}{0.1} \right) \times 10^{-3} + a \times L \times \left(\frac{P}{0.1} \right) \times 10^{-6} \right\} \times \frac{60}{t} \dots (5)$$

$$Q_r = \left\{ V_A \times \left(\frac{P+0.1}{0.1} \right) \times 10^{-3} + a \times L \times \left(\frac{P}{0.1} \right) \times 10^{-6} \right\} \times \frac{60}{t} \dots (6)$$

Q_r = Consumed air volume for rotary actuator [L/min (ANR)]

V_A = Inner volume of the rotary actuator (when pressurized from A port) [cm³]

V_B = Inner volume of the rotary actuator (when pressurized from B port) [cm³]

P = Operating pressure [MPa]

L = Length of piping [mm]

a = Inner sectional area of piping [mm²]

t = Total time for rotation [S]

Internal Cross Section of Tubing and Steel Tube

Nominal	O.D. [mm]	I.D. [mm]	Internal cross section a [mm ²]
T□ 0425	4	2.5	4.9
T□ 0604	6	4	12.6
TU 0805	8	5	19.6
T□ 0806	8	6	28.3
1/8B	—	6.5	33.2
T□ 1075	10	7.5	44.2
TU 1208	12	8	50.3
T□ 1209	12	9	63.6
1/4B	—	9.2	66.5
TS 1612	16	12	113
3/8B	—	12.7	127
T□ 1613	16	13	133
1/2B	—	16.1	204
3/4B	—	21.6	366
1B	—	27.6	598

⇒p. 14 Air consumption calculation graph

● Inner Volume and Air Consumption

[L (ANR)]

Size	Rotating angle (degree)	Inner volume [cm ³]		Operating pressure [MPa]									
		Press. V _A port	Press. V _B port	0.2	0.3	0.4	0.5	0.6	0.7	0.8	0.9	1.0	
10	90	0.5	0.8	0.004	0.005	0.007	0.008	0.009	0.010	—	—	—	
	180	1.1	1.1	0.007	0.009	0.011	0.013	0.015	0.018	—	—	—	
	270	1.5	1.5	0.009	0.012	0.015	0.018	0.021	0.024	—	—	—	
15	90	1.4	2.1	0.011	0.014	0.018	0.021	0.025	0.028	—	—	—	
	180	2.8	2.8	0.017	0.022	0.028	0.034	0.039	0.045	—	—	—	
	270	3.8	3.8	0.023	0.030	0.038	0.046	0.053	0.061	—	—	—	
20	90	3.6	5	0.026	0.034	0.043	0.052	0.060	0.069	—	—	—	
	180	6.5	6.5	0.039	0.052	0.065	0.078	0.091	0.104	—	—	—	
	270	7.9	7.9	0.047	0.063	0.079	0.095	0.111	0.126	—	—	—	
30	90	10.1	13.3	0.070	0.094	0.117	0.140	0.164	0.187	0.211	0.234	0.257	
	180	17.4	17.4	0.104	0.139	0.174	0.209	0.244	0.278	0.313	0.348	0.383	
	270	19	19	0.114	0.152	0.190	0.228	0.266	0.304	0.342	0.380	0.418	
40	90	21.9	30	0.156	0.208	0.260	0.311	0.363	0.415	0.467	0.519	0.571	
	180	37.5	37.5	0.225	0.300	0.375	0.450	0.525	0.600	0.675	0.750	0.825	
	270	41.6	41.6	0.250	0.333	0.416	0.499	0.582	0.666	0.749	0.832	0.915	

Rotary Actuator Model Selection

● Air Consumption Calculation Graph

Step 1 Using graph 4, air consumption volume of the rotary actuator is found. From the point of intersection between the inner volume and the operating pressure (slanted line) and then looking to the side (left side) direction, the air consumption volume for 1 cycle operation of a rotary actuator is found.

Step 2 Using graph 5, air consumption volume of tubing or steel tube is found.
 (1) First determine the point of intersection between the operating pressure (slanted line) and the piping length, and then go up the vertical line perpendicularly from there.
 (2) From the point of intersection of an operating piping tube inside diameter (slanted line), then look to the side (left or right) to find the required air consumption volume for piping.

Step 3 Total air consumption volume per minute is found as follows:
 (Air consumption volume of a rotary actuator [unit: L (ANR)] + Tubing or steel tube's air consumption volume) x Cycle times per minute x Number of rotary actuators = Total air consumption volume

Example) When 10 units of a CRBS30-180 are used at a pressure of 0.5 MPa, what is the air consumption of their 5 cycles per minute? (Piping between the actuator and switching valve is a tube with an inside diameter of 6 mm and length of 2 m.)

1. Operating pressure 0.5 MPa → Inner volume of CRBS30-180 34.8 cm³ → Air consumption volume 0.21 L (ANR)
2. Operating pressure 0.5 MPa → Piping length 2 m → Inside diameter 6 mm → Air consumption volume 0.56 L (ANR)
3. Total air consumption volume = (0.21 + 0.56) x 5 x 10 = 38.5 L/min (ANR)

Graph 4 Air Consumption

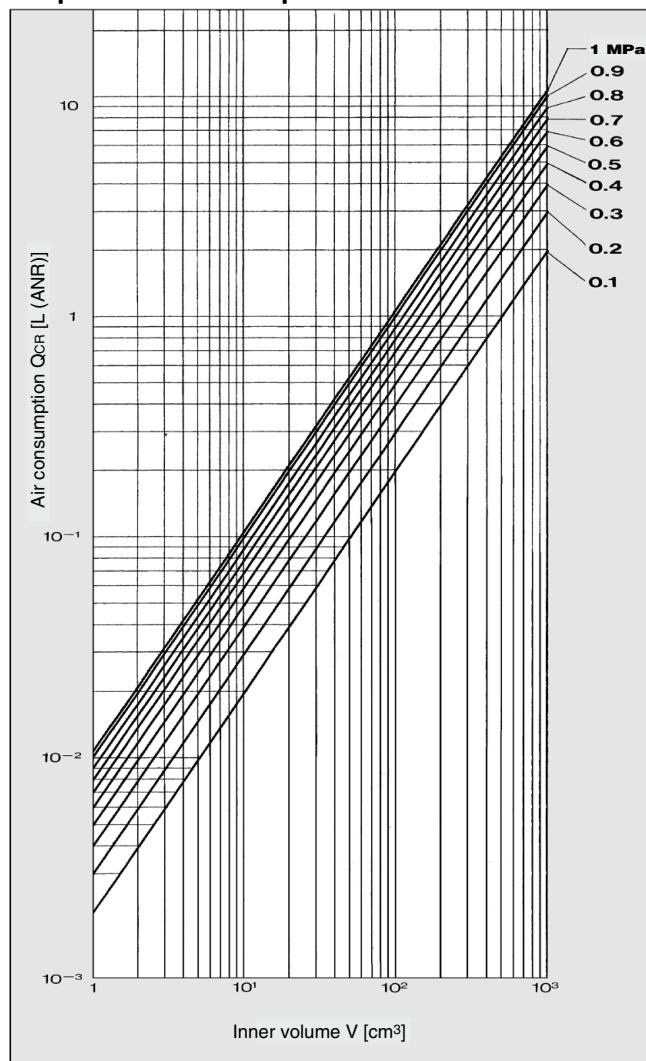

Inner Volume

1 cycle [cm³]

Size	Rotating angle		
	90°	180°	270°
10	1.3	2.2	3.0
15	3.5	5.6	7.6
20	8.6	13	15.8
30	23.4	34.8	38
40	51.9	75	83.2

Graph 5 Air Consumption of Tubing, Steel Tube (1 cycle)

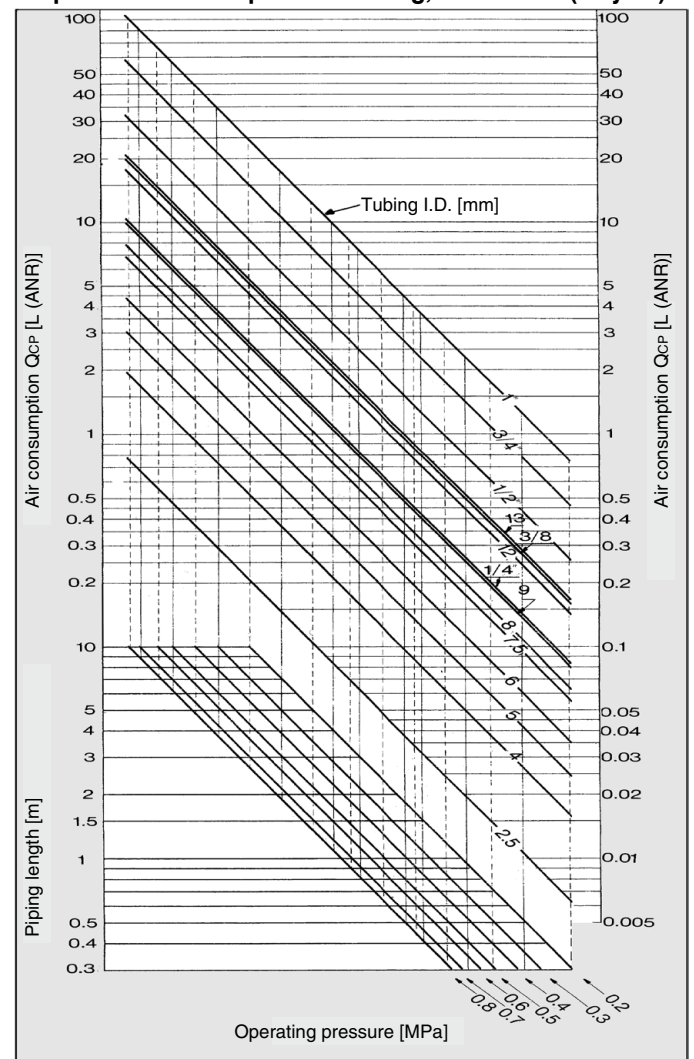

* "Piping length" indicates the length of steel tube or tubing which connects rotary actuator and switching valves (solenoid valves, etc.).
 * Refer to page 13 for the size of tubing and steel tube (inside diameter and outside diameter).

Model Selection

CRB

CRB□-A

CRB□-B/CRB□-C

Component Unit

Auto Switch Mounting

Vane Type Rotary Actuator

CRB Series

Size: 10, 15, 20, 30, 40



How to Order

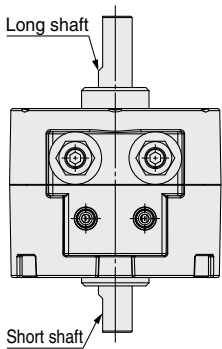
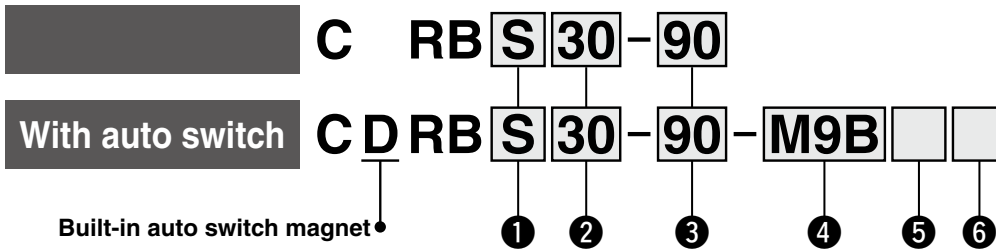

① Shaft type

Symbol	Shaft type	Shaft-end shape	
		Long shaft	Short shaft
S	Single shaft*1	Single flat*2	—
W	Double shaft	Single flat*2	Single flat
J *3	Double shaft	For details, refer to page 27.	
K *3	Double shaft		
T *3	Single shaft*1		
Y *3	Double shaft		

- *1 When an auto switch is mounted to the rotary actuator, only options "S" and "T" are available.
- *2 Size 40 has a parallel key instead of a chamfered portion.
- *3 Options "J," "K," "T," and "Y" are produced upon receipt of order.

② Size

10
15
20
30
40

③ Rotating angle

90	90°
180	180°
270	270°

* For models with an auto switch, only 90° or 180° can be selected.

④ Auto switch

Nil	Without auto switch (Built-in magnet)
------------	---------------------------------------

* For applicable auto switches, refer to the table below.

⑤ Lead wire length

Nil	Grommet/Lead wire: 0.5 m
M	Grommet/Lead wire: 1 m
L	Grommet/Lead wire: 3 m
Z *1	Grommet/Lead wire: 5 m

*1 The 5 m lead wire is produced upon receipt of order.

⑥ Number of auto switches

Nil	2
S	1

Refer to pages 47 to 50 for actuators with auto switches.

- Auto Switch Proper Mounting Position (at Rotation End Detection)
- Operating Angle and Hysteresis Angle
- Operating Range and Hysteresis
- How to Change the Auto Switch Detecting Position
- Auto Switch Mounting
- Auto Switch Adjustment

A flange mounting bracket assembly is available as an option. For details, refer to page 45.

Applicable Auto Switches/Refer to the Web Catalog for further information on auto switches.

Type	Electrical entry	Indicator/light	Wiring (Output)	Load voltage [DC]		Auto switch model	Lead wire type	Lead wire length [m]				Pre-wired connector	Applicable load	
								0.5 (Nil)	1 (M)	3 (L)	5 (Z)			
Solid state auto switch	Grommet	Yes	3-wire (NPN)	24 V	5 V, 12 V	M9N	Oilproof heavy-duty cord	●	●	●	○	○	IC circuit	Relay, PLC
			3-wire (PNP)					●	●	●	○			
			2-wire					●	●	●	○			

* Auto switches are shipped together with the product but do not come assembled.

* Auto switches marked with a "○" are produced upon receipt of order.



Symbol

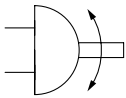

Specifications

Size	10	15	20	30	40
Rotating angle range	90 ^{+5°} ₀	90 ^{+4°} ₀	90 ^{±10°}		
	180 ^{+5°} ₀	180 ^{+4°} ₀	180 ^{±10°}		
	270 ^{+5°} ₀	270 ^{+4°} ₀	270 ^{+4°} ₀		
Fluid	Air (Non-lube)				
Proof pressure [MPa]	1.05			1.5	
Ambient and fluid temperatures	5 to 60°C				
Max. operating pressure [MPa]	0.7			1.0	
Min. operating pressure [MPa]	0.2				
Rotation time adjustment range [s/90°] ^{*1}	0.03 to 0.5			0.04 to 0.5	0.07 to 0.5
Allowable kinetic energy [J]	0.00015	0.001	0.003	0.02	0.04
Shaft load [N]	Allowable radial load	15	15	25	30
	Allowable thrust load	10	10	20	25
Port size	M5 x 0.8 (90° and 180° specifications) M3 x 0.5 (270° specification)			M5 x 0.8	

*1 Operate within the specified rotation time range. Operation below 0.5 s/90° may cause stick slip or operation failure.

It is difficult to make adjustments during use if rotation time is changed to 0.5 s/90° or lower.

Size 10 requires at least 0.35 MPa of operating pressure to reach the minimum rotation time (0.03 s/90°).

Chamfered Portion and Rotation Range: Top View from Long Shaft Side

The positions of the chamfered portion shown below illustrate the conditions of actuators when B port is pressurized.

• Operate within the adjustment range shown below.

Size: 10, 15

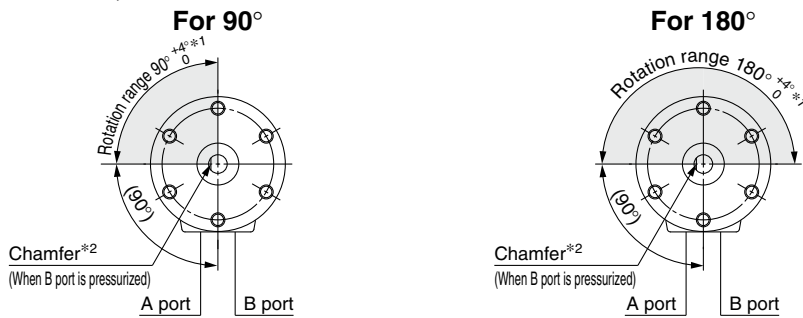

*1 For size 10, the tolerance of rotating angle of 90° and 180° will be ^{+5°}₀.

Size: 20, 30, 40

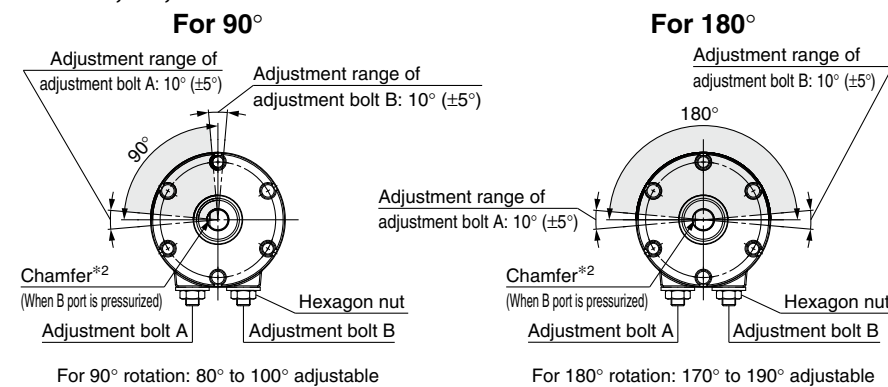

*2 For size 40 actuators, a parallel key will be used instead of a chamfer.

* The angle adjusting screw (adjustment bolt) is set at random within the adjustable rotating range. Therefore, it must be readjusted to obtain the angle that suits your application. (Refer to page 52.)

Size: 10, 15, 20, 30, 40

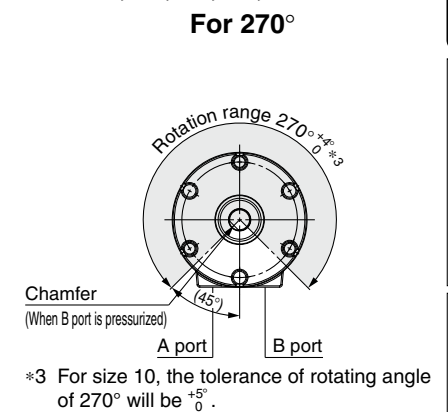

*3 For size 10, the tolerance of rotating angle of 270° will be ^{+5°}₀.

The position of the chamfered portion when A port is pressurized (when shipped from the factory)

Size: 10, 15, 20, 30, 40

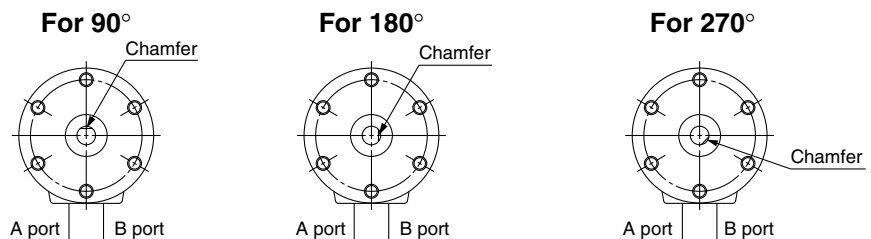

☆ Recommended tightening torque for hexagon nut to fix the adjustment bolt
Size 20: 1.5 N·m Sizes 30, 40: 3 N·m

CRB Series

Inner Volume

Size	10			15			20			30			40		
	90°	180°	270°	90°	180°	270°	90°	180°	270°	90°	180°	270°	90°	180°	270°
Rotating angle	90°	180°	270°	90°	180°	270°	90°	180°	270°	90°	180°	270°	90°	180°	270°
Inner volume	0.8 (0.5)	1.1	1.5	2.1 (1.4)	2.8	3.8	5 (3.6)	6.5	7.9	13.3 (10.1)	17.4	19	30 (21.9)	37.5	41.6

* Values inside () are inner volume of the supply side when A port is pressurized.

Weight

Size	10			15			20			30			40		
	90°	180°	270°	90°	180°	270°	90°	180°	270°	90°	180°	270°	90°	180°	270°
Rotating angle	90°	180°	270°	90°	180°	270°	90°	180°	270°	90°	180°	270°	90°	180°	270°
Basic type (S shaft)	26 (27)	25 (26)	25 (26)	46 (47)	45 (46)	45 (46)	107 (110)	105 (107)	103 (106)	198 (203)	192 (197)	190 (195)	366 (378)	354 (360)	360 (366)
With auto switch	39	38	—	62	61	—	115	112	—	216	209	—	380	367	—

(): For W shaft

Effective Output

Size 10

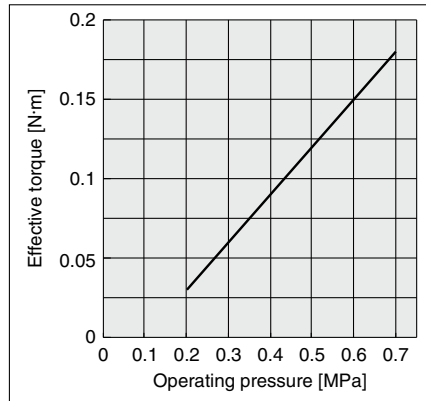

Size 15

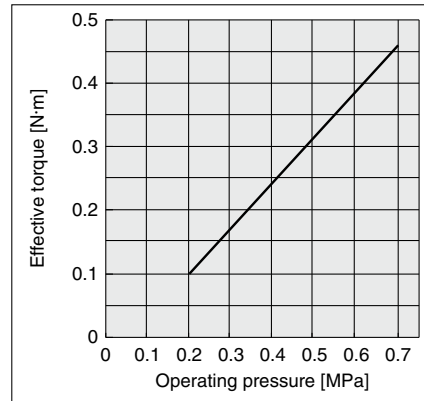

Size 20

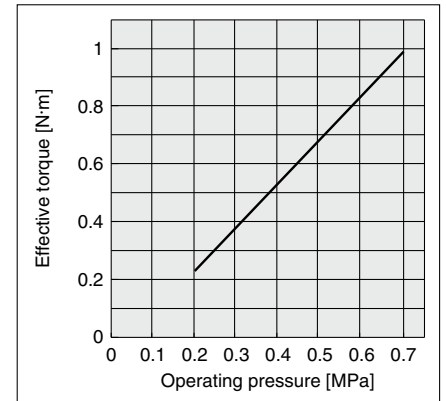

Size 30

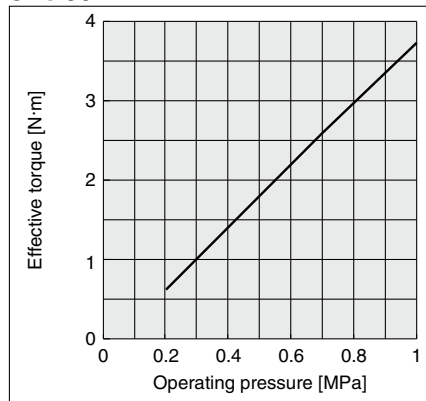

Size 40

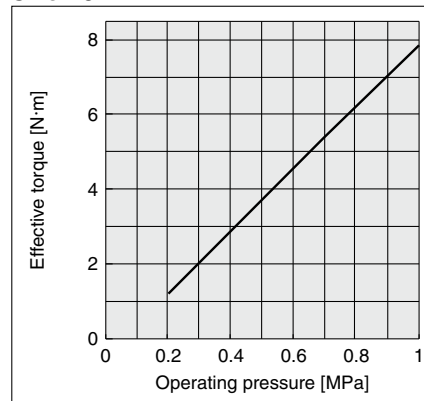

Construction: Standard Type (Without Auto Switch)

• Following figures show actuators when B port is pressurized.

Size: 10, 15

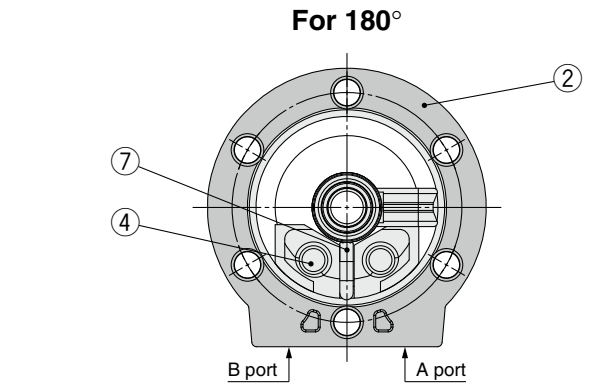
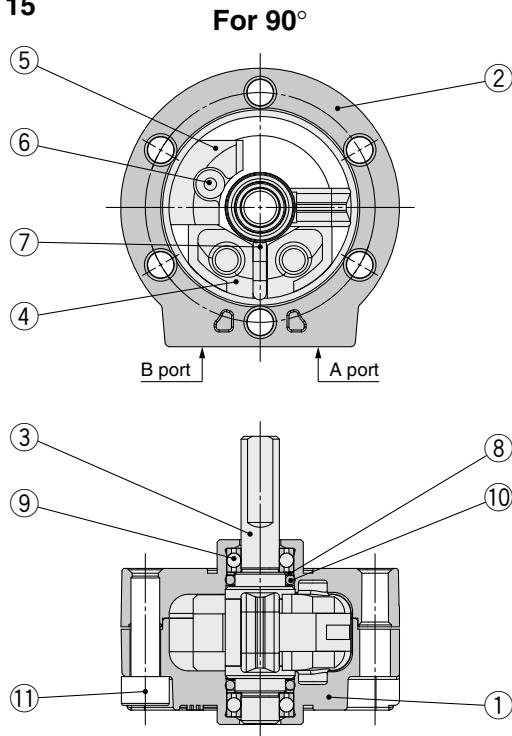

Component Parts

No.	Description	Material	Note
1	Body (A)	Aluminum alloy	Painted
2	Body (B)	Aluminum alloy	Painted
3	Vane shaft	Stainless steel	
4	Stopper	Resin	
5	Stopper for 90°	Resin	For 90°
6	Holding rubber	NBR	For 90°
7	Stopper seal	NBR	Special seal
8	Back-up ring	Stainless steel	
9	Bearing	Bearing steel	
10	O-ring	NBR	
11	Hexagon socket head cap screw	Chrome molybdenum steel	Special screw

Size: 20, 30, 40

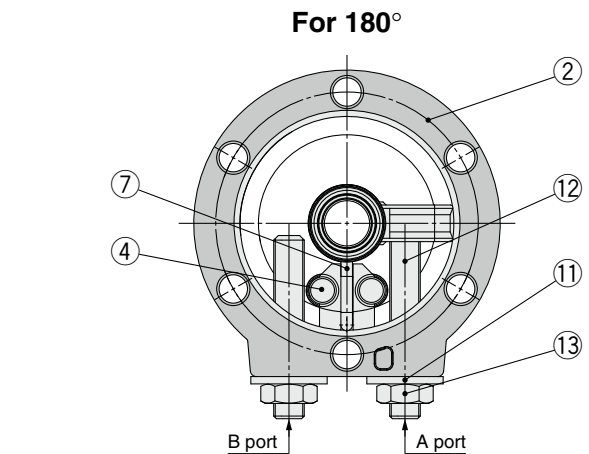
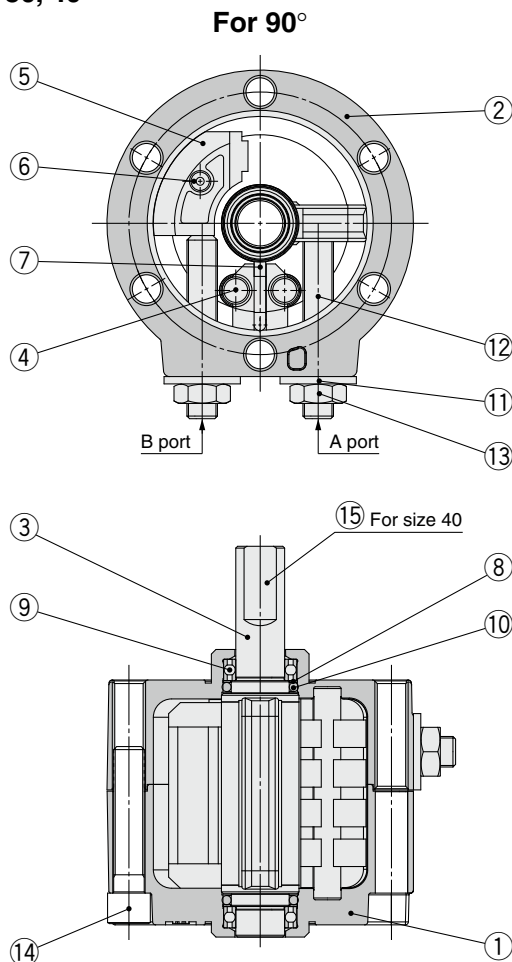

Component Parts

No.	Description	Material	Note
1	Body (A)	Aluminum alloy	Painted
2	Body (B)	Aluminum alloy	Painted
3	Vane shaft	Stainless steel*1	
4	Stopper	Resin	
5	Stopper for 90°	Resin	For 90°
6	Holding rubber	NBR	For 90°
7	Stopper seal	NBR	Special seal
8	Back-up ring	Stainless steel	
9	Bearing	Bearing steel	
10	O-ring	NBR	
11	Seal washer	NBR	
12	Adjustment bolt	Chrome molybdenum steel	
13	Hexagon nut	Steel wire	
14	Hexagon socket head cap screw	Chrome molybdenum steel	Special screw
15	Parallel key	Carbon steel	Size 40 only

*1 The material is chrome molybdenum steel for sizes 30 and 40.

CRB Series

Construction: Standard Type (Without Auto Switch)

• Following figures show the position of the ports during rotation.

Size: 10, 15, 20, 30, 40
For 270°

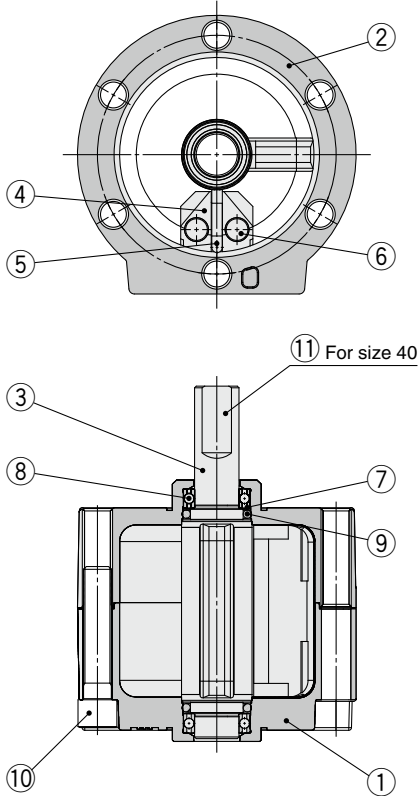

Component Parts

No.	Description	Material	Note
1	Body (A)	Aluminum alloy	Painted
2	Body (B)	Aluminum alloy	Painted
3	Vane shaft	Stainless steel*1	
4	Stopper	Resin	
5	Stopper seal	NBR	Special seal
6	Stopper pin	Bearing steel	
7	Back-up ring	Stainless steel	
8	Bearing	Bearing steel	
9	O-ring	NBR	
10	Hexagon socket head cap screw	Chrome molybdenum steel	Special screw
11	Parallel key	Carbon steel	Size 40 only

*1 The material is chrome molybdenum steel for sizes 30 and 40.

Construction: Standard Type (With Auto Switch)

• Following figures show actuators when B port is pressurized.

Size: 10, 15

Size: 20, 30, 40

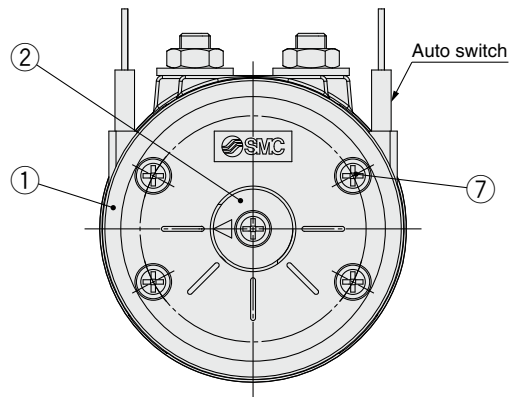
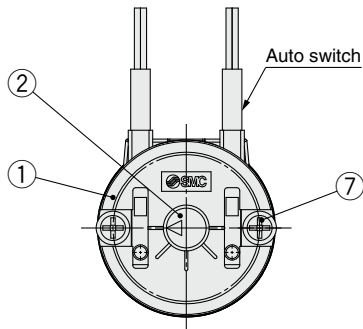
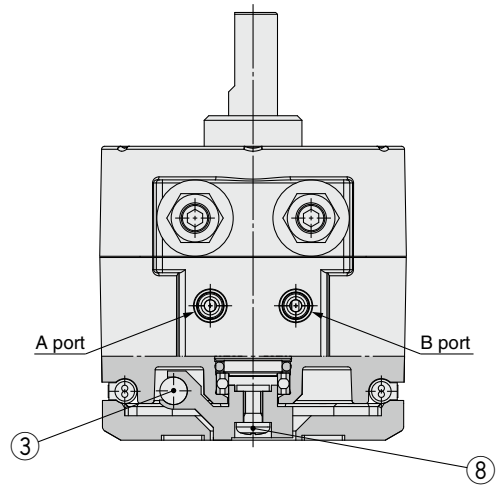
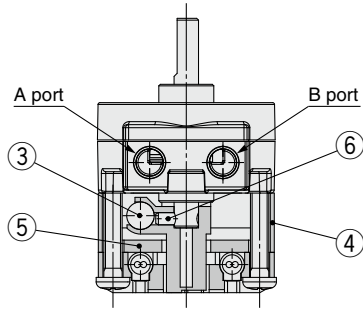

Component Parts

No.	Description	Material
1	Cover	Resin
2	Magnet holder	Resin
3	Magnet	Magnetic material
4	Body C	Resin
5	Switch plate	Aluminum alloy
6	Spring pin	Stainless steel
7	Cross recessed round head screw	Chrome molybdenum steel ^{*1}
8	Cross recessed round head screw	Chrome molybdenum steel

*1 The material is stainless steel for sizes 10 and 15.

Model Selection

CRB

CRB□-A

CRB□-B/CRB□-C

Component Unit

Auto Switch Mounting

CRB Series

Dimensions: Standard Type (Without Auto Switch) 10, 15

Single shaft: CRBS (For 90° and 180°)

• Following figures show actuators when B port is pressurized.

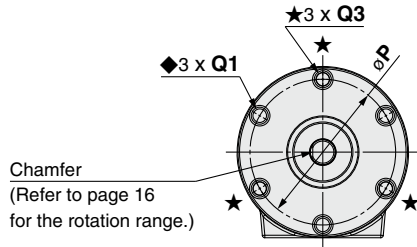

Chamfer
(Refer to page 16
for the rotation range.)

(3 mounting holes with the ★ marks are for tightening the actuator and not to be used for external mounting for size 10.)

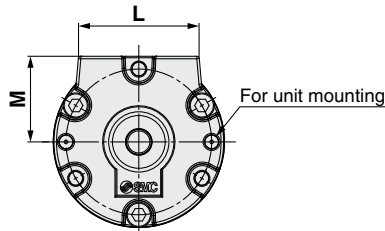
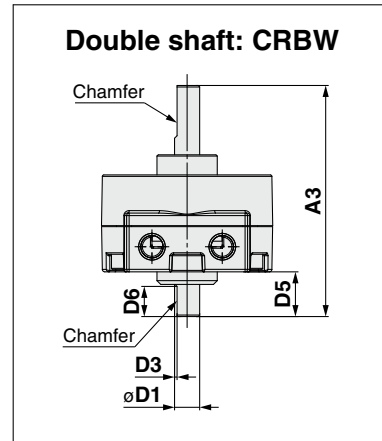
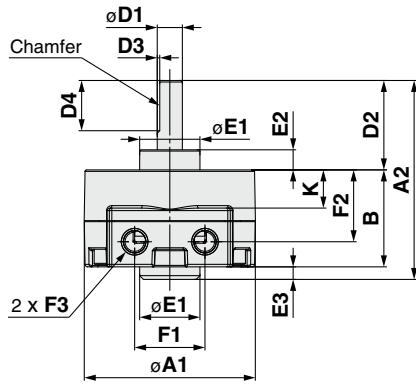
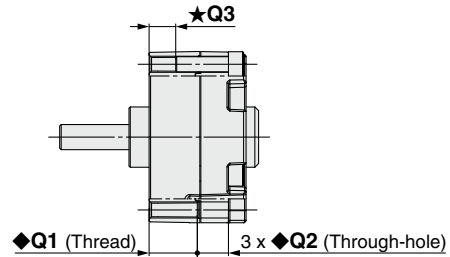

Size	A			B	D						E			F			K
	A1	A2	A3		D1 (g7)	D2	D3	D4	D5	D6	E1 (h9)	E2	E3	F1	F2	F3	
10	29	30	37	15	4 ^{-0.004} _{-0.015}	14	0.5	9	8	5	9 ⁰ _{-0.036}	3	1	12	9.8	M5 x 0.8	3.6
15	34	39.5	47	20	5 ^{-0.004} _{-0.016}	18	0.5	10	9	6	12 ⁰ _{-0.043}	4	1.5	14	14.3	M5 x 0.8	7.6

Size	L	M	P	Q		
				◆Q1	◆Q2	★Q3
10	19.8	14.6	24	M3 x 0.5 depth 6	6	—
15	24	17.1	29	M3 x 0.5 depth 10	6	M3 x 0.5 depth 5

Dimensions: Standard Type (Without Auto Switch) 10, 15

Single shaft: CRBS (For 270°)

• Following figures show the position of the ports during rotation.

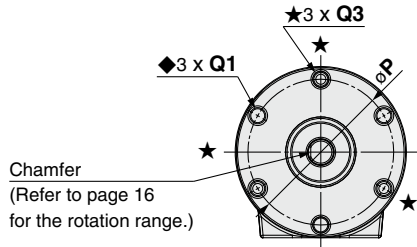

(3 mounting holes with the ★ marks are for tightening the actuator and not to be used for external mounting for size 10.)

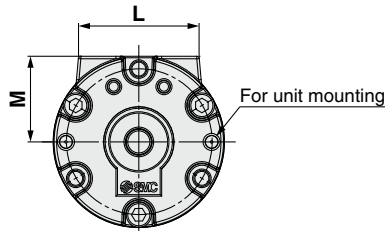
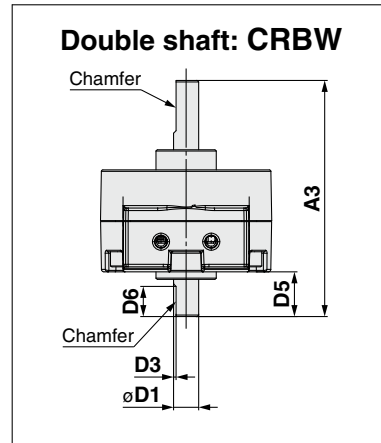
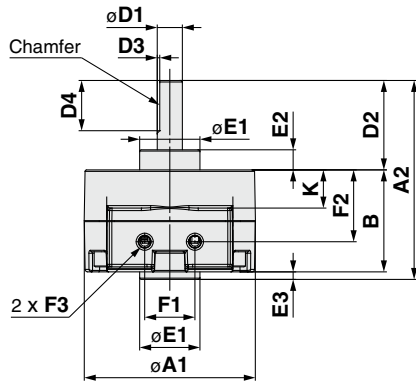
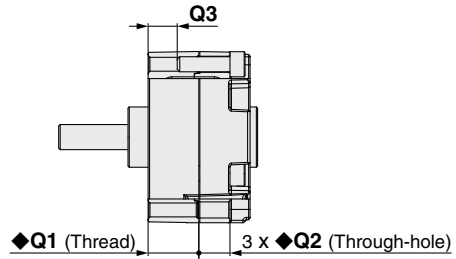

Size	A			B	D						E			F			K
	A1	A2	A3		D1(g7)	D2	D3	D4	D5	D6	E1(h9)	E2	E3	F1	F2	F3	
10	29	30	37	15	4 ^{-0.004} _{-0.015}	14	0.5	9	8	5	9 ⁰ _{-0.036}	3	1	9.5	9.8	M3 x 0.5	3.6
15	34	39.5	47	20	5 ^{-0.005} _{-0.016}	18	0.5	10	9	6	12 ⁰ _{-0.043}	4	1.5	10	14.3	M3 x 0.5	7.6

Size	L	M	P	Q		
				◆Q1	◆Q2	★Q3
10	19.8	14.6	24	M3 x 0.5 depth 6	6	—
15	24	17.1	29	M3 x 0.5 depth 10	6	M3 x 0.5 depth 5

Model Selection

CRB

CRB□-A

CRB□-B/CRB□-C

Component Unit

Auto Switch Mounting

CRB Series

Dimensions: Standard Type (Without Auto Switch) 20, 30, 40

Single shaft: CRBS (For 90° and 180°)

• Following figures show actuators when B port is pressurized.

For size 40

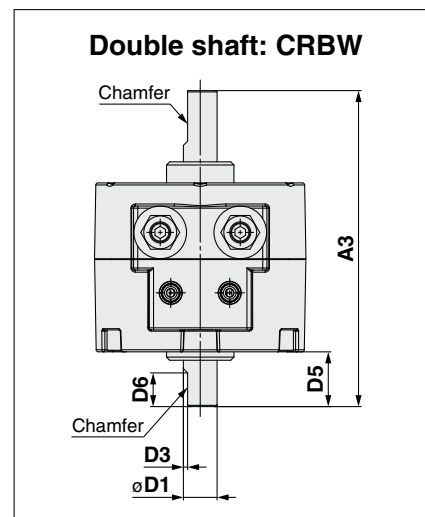
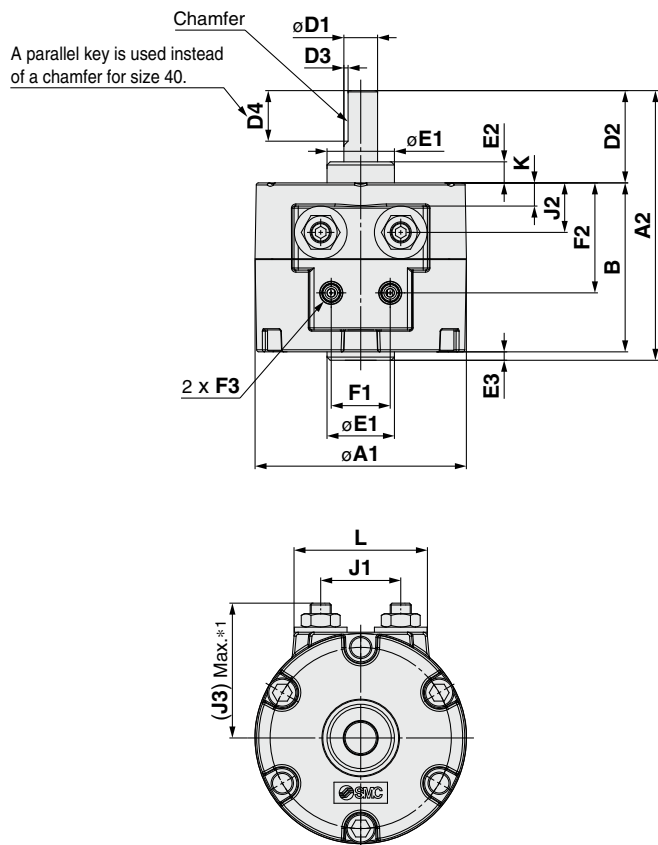
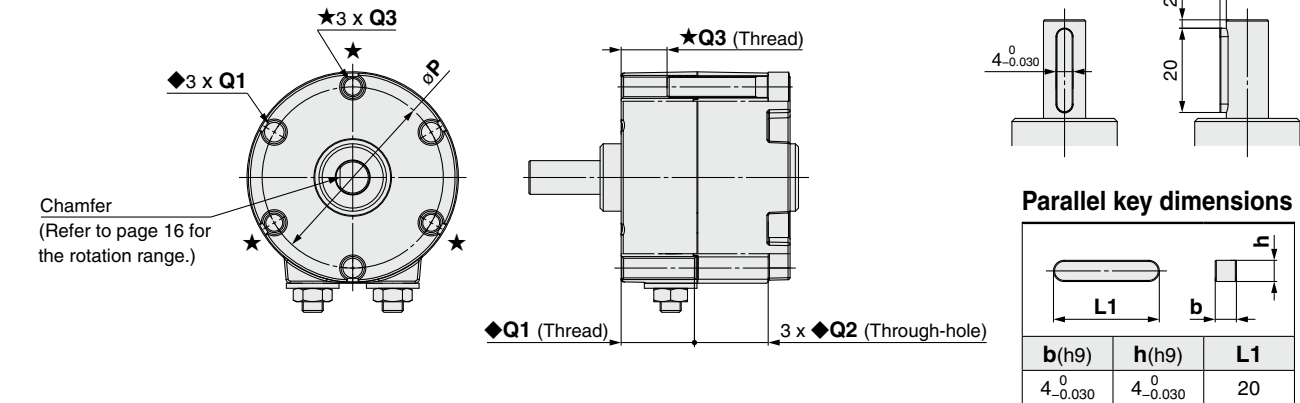

Size	A			B	D						E			F		
	A1	A2	A3		D1(g7)	D2	D3	D4	D5	D6	E1(h9)	E2	E3	F1	F2	F3
20	42	50.5	59	29	6 ^{-0.004} _{-0.016}	20	0.5	10	10	7	14 ⁰ _{-0.043}	4.5	1.5	13	18.3	M5 x 0.8
30	50	64	75	40	8 ^{-0.005} _{-0.020}	22	1	12	13	8	16 ⁰ _{-0.043}	5	2	14	26	M5 x 0.8
40	63	79.5	90	45	10 ^{-0.005} _{-0.020}	30	1	—	15	9	25 ⁰ _{-0.052}	6.5	4.5	20	31.1	M5 x 0.8

Size	J			K	L	P	Q		
	J1	J2	J3				◆Q1	◆Q2	★Q3
20	16	7.1	27.4	—	28	36	M4 x 0.7 depth 10	11	M4 x 0.7 depth 7.5
30	19	11.8	32.7	5.5	31.5	43	M5 x 0.8 depth 15	16.5	M5 x 0.8 depth 10
40	28	15.8	44.1	9.5	40	56	M5 x 0.8 depth 20	17.5	M5 x 0.8 depth 10

*1 J3-dimension is not the dimension at the time of shipment, since its dimension is for adjustment parts.

Dimensions: Standard Type (Without Auto Switch) 20, 30, 40

Single shaft: CRBS (For 270°)

• Following figures show the position of the ports during rotation.

For size 40

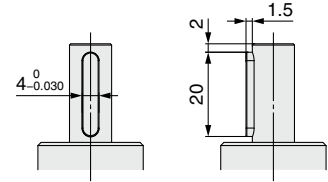
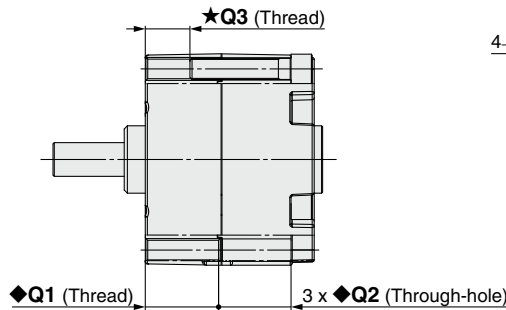
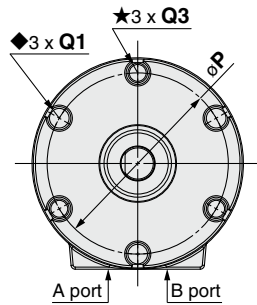

Parallel key dimensions

b(h9)	h(h9)	L1
$4_{-0.030}^0$	$4_{-0.030}^0$	20

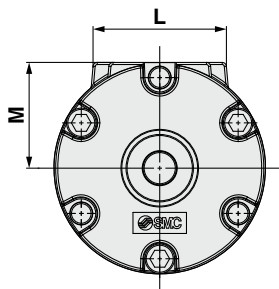
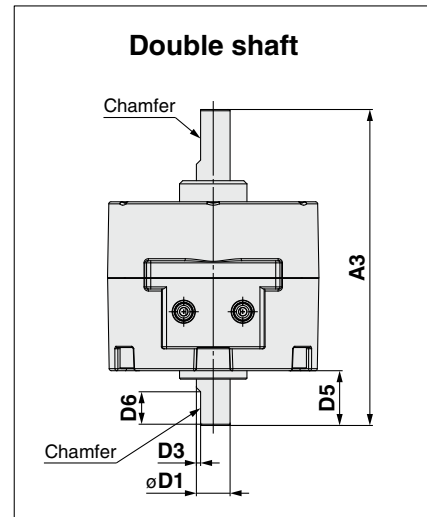
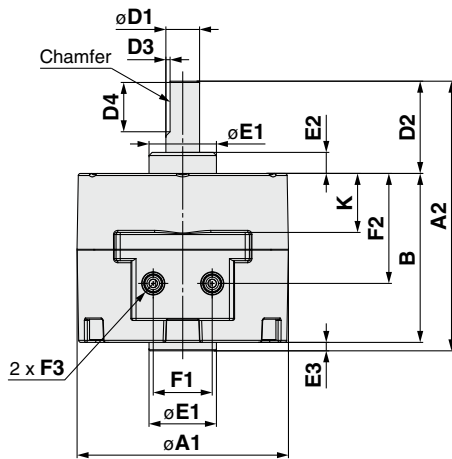

Size	A			B	D						E			F		
	A1	A2	A3		D1(g7)	D2	D3	D4	D5	D6	E1(h9)	E2	E3	F1	F2	F3
20	42	50.5	59	29	$6_{-0.016}^{-0.004}$	20	0.5	10	10	7	$14_{-0.043}^0$	4.5	1.5	13	18.3	M5 x 0.8
30	50	64	75	40	$8_{-0.020}^{-0.005}$	22	1	12	13	8	$16_{-0.043}^0$	5	2	14	26	M5 x 0.8
40	63	79.5	90	45	$10_{-0.020}^{-0.005}$	30	1	—	15	9	$25_{-0.052}^0$	6.5	4.5	20	31.1	M5 x 0.8

Size	K	L	M	P	Q		
					◆Q1	◆Q2	★Q3
20	10.5	28	21	36	M4 x 0.7 depth 10	11	M4 x 0.7 depth 7.5
30	14	31.5	25	43	M5 x 0.8 depth 15	16.5	M5 x 0.8 depth 10
40	17	40	31.6	56	M5 x 0.8 depth 20	17.5	M5 x 0.8 depth 10

Model Selection

CRB

CRB-A

CRB-B/CRB-C

Component Unit

Auto Switch Mounting

CRB Series

Dimensions: Standard Type (With Auto Switch) 10, 15

Single shaft: CDRBS (For 90° and 180°)

• Following figures show actuators when B port is pressurized.

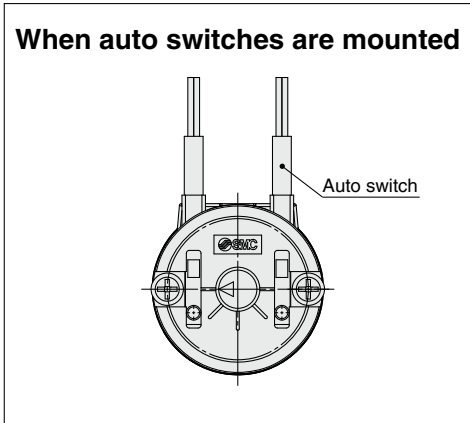
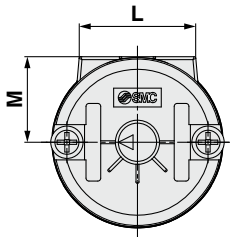
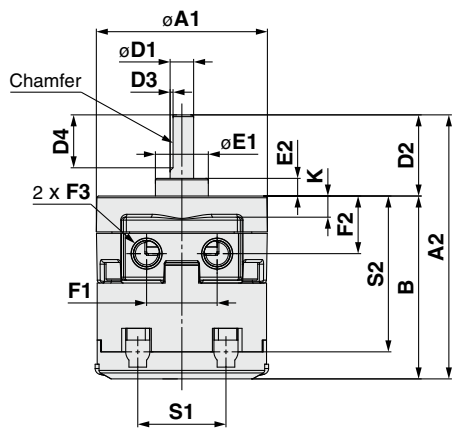
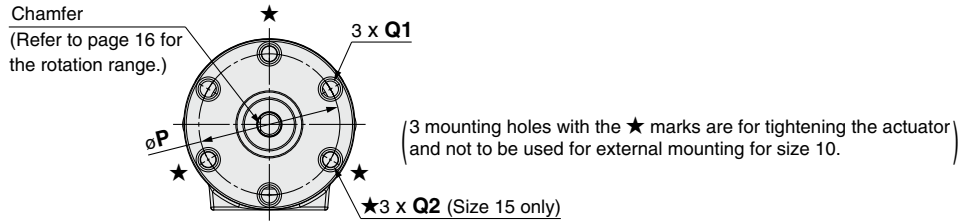

Size	A		B	D				E		F			K	L	M	P
	A1	A2		D1(g7)	D2	D3	D4	E1(h9)	E2	F1	F2	F3				
10	29	46	32	4 ^{-0.004} _{-0.015}	14	0.5	9	9 ⁰ _{-0.036}	3	12	9.8	M5 x 0.8	3.6	19.8	14.6	24
15	34	54.8	36.8	5 ^{-0.004} _{-0.016}	18	0.5	10	12 ⁰ _{-0.043}	4	14	14.3	M5 x 0.8	7.6	24	17.1	29
Size	Q		S													
	◆Q1	★Q2	S1	S2												
10	M3 x 0.5 depth 6	—	15	27												
15	M3 x 0.5 depth 10	M3 x 0.5 depth 5	19	32.2												

Dimensions: Standard Type (With Auto Switch) 20, 30, 40

Single shaft: CDRBS (For 90° and 180°)

• Following figures show actuators when B port is pressurized.

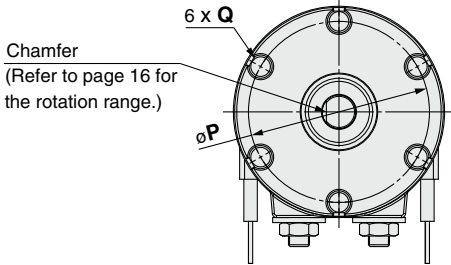

For size 40

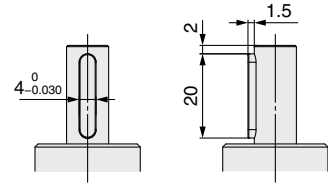

Parallel key dimensions

b(h9)	h(h9)	L1
4_{-0.030}^0	4_{-0.030}^0	20

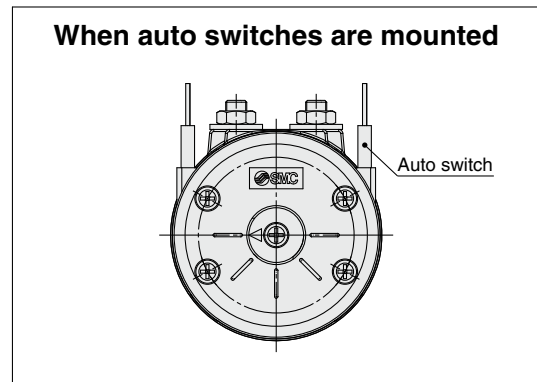
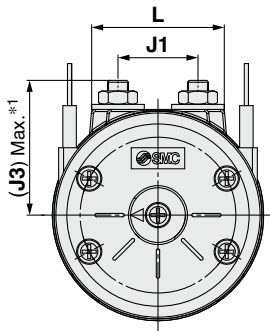
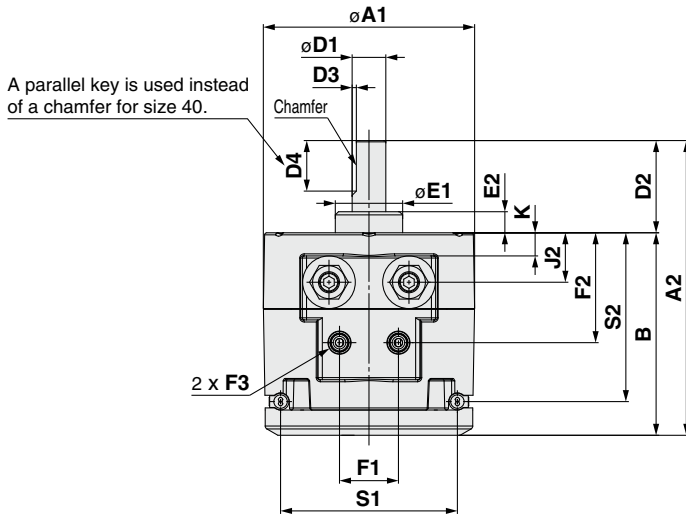

Size	A		B	D				E		F			J			K
	A1	A2		D1(g7)	D2	D3	D4	E1(h9)	E2	F1	F2	F3	J1	J2	J3	
20	42	55.6	35.6	6 ^{-0.004} _{-0.016}	20	0.5	10	14 ⁰ _{-0.043}	4.5	13	18.3	M5 x 0.8	16	7.1	27.4	—
30	50	70	48	8 ^{-0.005} _{-0.020}	22	1	12	16 ⁰ _{-0.043}	5	14	26	M5 x 0.8	19	11.8	32.7	5.5
40	63	84.2	54.2	10 ^{-0.005} _{-0.020}	30	—	—	25 ⁰ _{-0.052}	6.5	20	31.1	M5 x 0.8	28	15.8	44.1	9.5

Size	L	P	Q	S	
				S1	S2
20	28	36	M4 x 0.7 depth 10	37	28.6
30	31.5	43	M5 x 0.8 depth 15	42	40.1
40	40	56	M5 x 0.8 depth 20	52	45.2

*1 J3-dimension is not the dimension at the time of shipment, since its dimension is for adjustment parts.

Model Selection

CRB

CRB□-A

CRB□-B/CRB□-C

Component Unit

Auto Switch Mounting

CRB Series

Shaft Type Dimensions (Dimensions other than specified below are the same as those of the standard type.)

Size: 10, 15

Standard type

Double shaft: CRBJ□

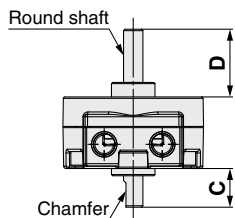

Double shaft: CRBK□

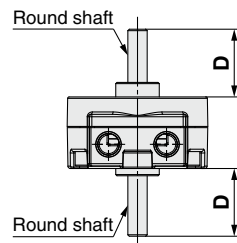

Single shaft: CRBT□

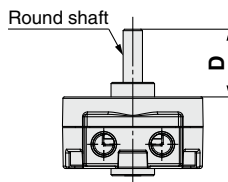

Double shaft: CRBY□

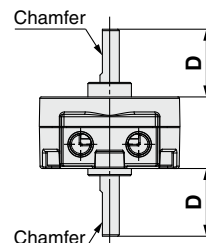

With auto switch

Single shaft: CDRBT□

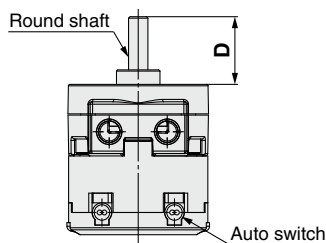

	[mm]	
Size	10	15
C	8	9
D	14	18

* The dimensions of the shaft and chamfer are the same as those of the standard type. Dimensions of parts different from the standard type conform to the general tolerance.

Size: 20, 30, 40

Standard type

Double shaft: CRBJ□

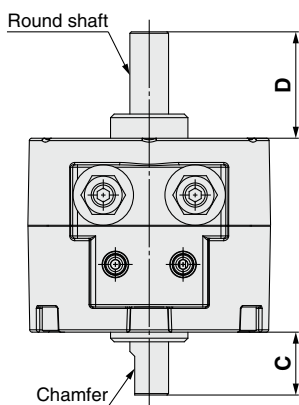

Double shaft: CRBK□

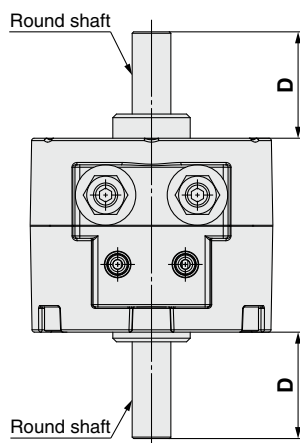

Single shaft: CRBT□

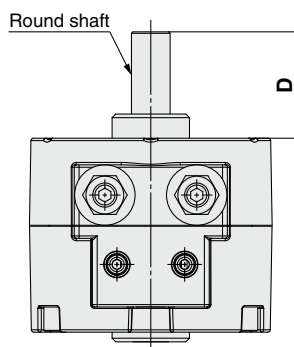

Double shaft: CRBY□

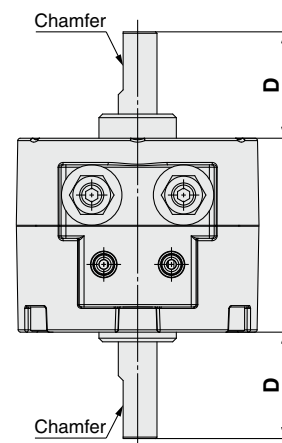

With auto switch

Single shaft: CDRBT□

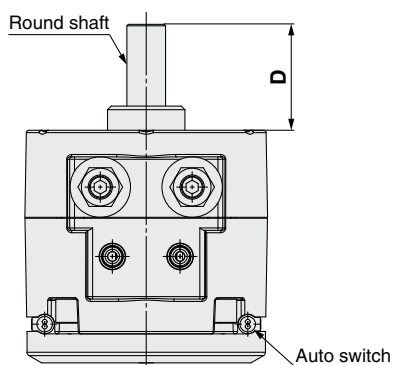

A parallel key is used instead of a chamfer for size 40.

	[mm]		
Size	20	30	40
C	10	13	15
D	20	22	30

* The dimensions of the shaft and chamfer (a parallel key for size 40) are the same as those of the standard type. Dimensions of parts different from the standard type conform to the general tolerance.

Vane Type Rotary Actuator With Vertical Auto Switch Unit

CRB□-A Series

Size: 10, 15, 20, 30, 40



How to Order

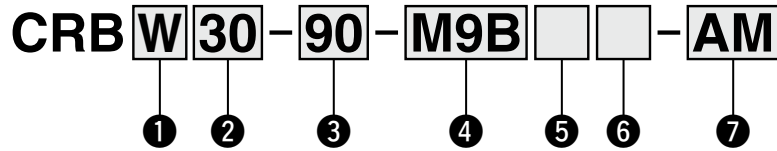

① Shaft type

Symbol	Shaft type	Shaft-end shape	
		Long shaft	Short shaft
W	Double shaft	Single flat* ¹	Single flat* ³
J * ²	Double shaft	Round shaft	Single flat* ³

- *1 Size 40 has a parallel key instead of a chamfered portion.
- *2 Option "J" is produced upon receipt of order.
- *3 A vertical auto switch unit can be mounted to the short shaft side.

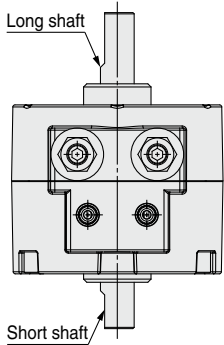

② Size

10
15
20
30
40

③ Rotating angle

90	90°
180	180°
270	270°

⑤ Lead wire length

Nil	Grommet/Lead wire: 0.5 m
M	Grommet/Lead wire: 1 m
L	Grommet/Lead wire: 3 m
CN	Connector/Without lead wire
C	Connector/Lead wire: 0.5 m
CL	Connector/Lead wire: 3 m
Z * ¹	Grommet/Lead wire: 5 m

- *1 The 5 m lead wire is produced upon receipt of order.
- * Connectors are only available for the R73, R80, and T79.
- * Lead wire with connector part nos.
D-LC05: Lead wire 0.5 m
D-LC30: Lead wire 3 m
D-LC50: Lead wire 5 m

④ Auto switch

- * For applicable auto switches, refer to the table below.

⑥ Number of auto switches

Nil	2
S	1

⑦ Auto switch unit

Symbol	Description	Applicable auto switch
A	With vertical auto switch unit (Built-in magnet)	Other than the D-M9□(V) → Refer to pages 49 and 50.
AM	With vertical auto switch unit for the D-M9 (Built-in magnet)	D-M9□(V) → Refer to page 48.

- * Refer to page 46 if the auto switch unit is needed separately.

Applicable Auto Switches/Refer to the Web Catalog for further information on auto switches.

Applicable size	Type	Special function	Electrical entry	Indicator/light	Wiring (Output)	Load voltage		Auto switch model		Lead wire type	Lead wire length [m]					Pre-wired connector	Applicable load			
						DC	AC	Perpendicular	In-line		0.5 (Nil)	1 (M)	3 (L)	5 (Z)	None (N)		Relay, PLC	IC circuit		
																			24 V	5 V, 12 V, 24 V
For 10, 15	Solid state auto switch	—	Grommet	Yes	3-wire (NPN)	24 V	5 V, 12 V	—	M9NV	M9N	Oilproof heavy-duty cord	●	●	●	○	—	○	IC circuit	Relay, PLC	
					3-wire (PNP)				M9PV	M9P		●	●	●	○	—	○			IC circuit
					2-wire				M9BV	M9B		●	●	●	○	—	○			
	Reed auto switch	—	—	No	2-wire	24 V	5 V, 12 V, 100 V	5 V, 12 V, 24 V	—	90	Vinyl parallel cord	●	—	●	●	—	—	IC circuit	Relay, PLC	
									—	97		Oilproof heavy-duty cord	●	—	●	●	—			—
									—	93A			●	—	●	●	—			—
For 20, 30, 40	Solid state auto switch	—	Grommet	Yes	3-wire (NPN)	24 V	5 V, 12 V	—	M9NV	M9N	Oilproof heavy-duty cord	●	●	●	○	—	○	IC circuit	Relay, PLC	
					3-wire (PNP)				M9PV	M9P		●	●	●	○	—	○			
					2-wire				M9BV	M9B		●	●	●	○	—	○			
					3-wire (NPN)				—	S79		●	—	●	○	—	○			
					3-wire (PNP)				—	S7P		●	—	●	○	—	○			
					2-wire				—	T79		●	—	●	○	—	○			
	Reed auto switch	—	—	Connector	Yes	2-wire	48 V, 100 V	100 V	—	R73	Oilproof heavy-duty cord	●	—	●	○	—	—	—	Relay, PLC	
									—	R73C		●	—	●	○	—	—			
									—	R80		●	—	●	○	—	—			
									—	R80C		●	—	●	○	—	—			
									—	—		●	—	●	○	—	—			
									—	—		●	—	●	○	—	—			

- * Auto switches are shipped together with the product but do not come assembled.
- * Auto switches marked with a "○" are produced upon receipt of order.

CRB□-A Series

Specifications, rotation range, inner volume, and effective output are the same as those of the standard type. (→ p. 16, 17)

Weight

Size	10			15			20			30			40		
	90°	180°	270°	90°	180°	270°	90°	180°	270°	90°	180°	270°	90°	180°	270°
Basic type	27	26	26	47	46	46	110	107	106	203	197	195	378	360	366
Vertical auto switch unit	15			20			28			38			43		

A flange mounting bracket assembly is available as an option. For details, refer to page 45.

Construction: With Vertical Auto Switch Unit

• Components other than those specified below are the same as those of the standard type.

D-M9□

Size: 10, 15

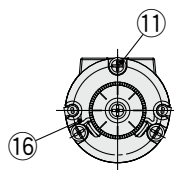
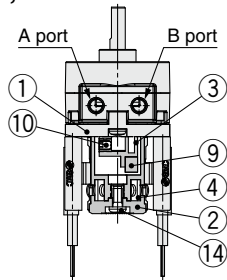

Size: 20, 30

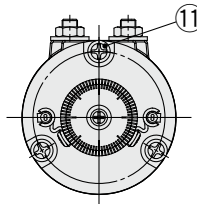
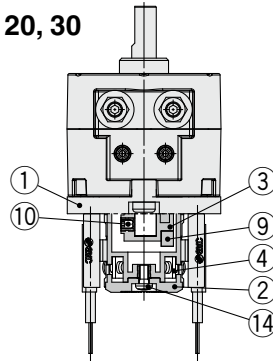

Size: 40

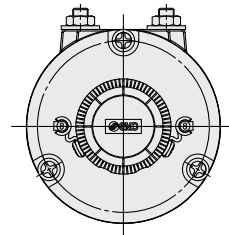
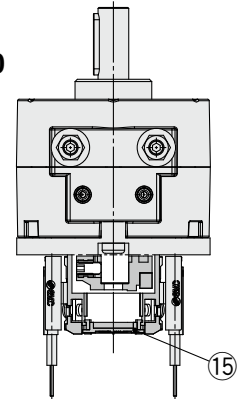

D-S/T99(V) D-S7P D-90/90A
D-S9P(V) D-97/93A D-R73/80□
D-S/T79□

Size: 10, 15

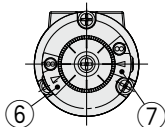
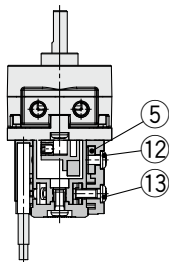

Size: 20, 30

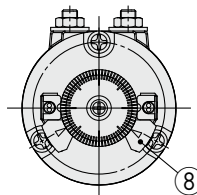
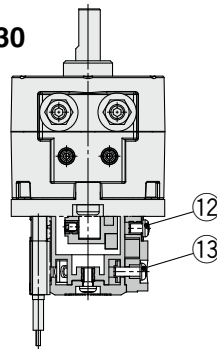

Size: 40

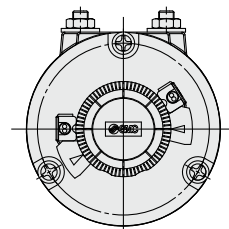
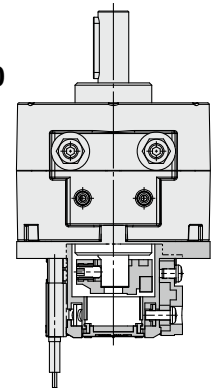

Component Parts

No.	Description	Material
1	Cover (A)	Resin
2	Cover (B)	Resin
3	Magnet lever	Resin
4	Holding block	Stainless steel
5	Holding block (B)	Aluminum alloy
6	Switch block (A)	Resin

Component Parts

No.	Description	Material
7	Switch block (B)	Resin
8	Switch block	Resin
9	Magnet	
10	Hexagon socket set screw	Stainless steel
11	Cross recessed round head screw	Stainless steel
12	Cross recessed round head screw	Stainless steel

Component Parts

No.	Description	Material
13	Cross recessed round head screw	Stainless steel
14	Cross recessed round head screw	Stainless steel
15	Rubber cap	NBR
16	Switch holder	Stainless steel

* For size 10, there are 2 pcs. of ⑪ cross recessed round head screws.

Dimensions: With Vertical Auto Switch Unit (10, 15)

CRBW-A (For 90° and 180°)

• Following figures show actuators when B port is pressurized.

(3 mounting holes with the ★ marks are for tightening the actuator) and not to be used for external mounting for size 10.

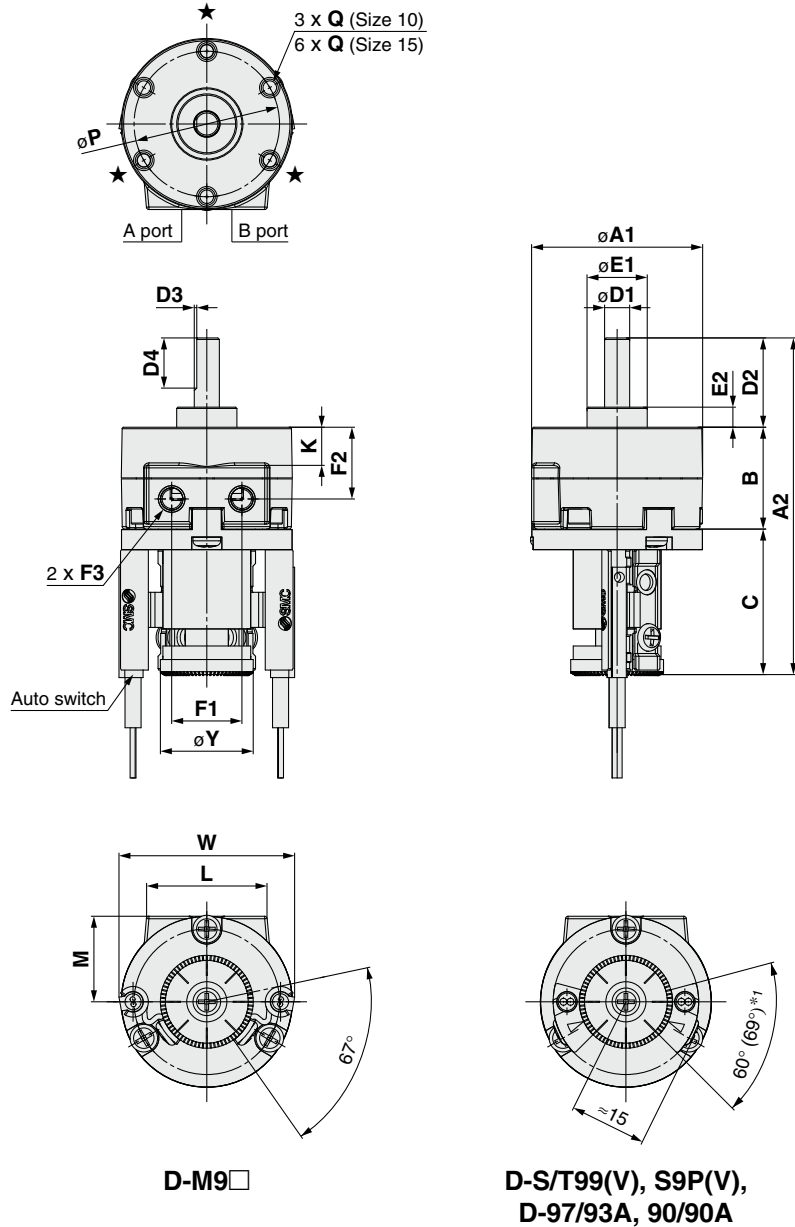

*1 The angle is 60° when any of the following are used: D-90/90A/97/93A
The angle is 69° when any of the following are used: D-S99(V)/T99(V)/S9P(V)

Size	A		B	C	D				E		F			K	L	M	P
	A1	A2			D1(g7)	D2	D3	D4	E1(h9)	E2	F1	F2	F3				
10	29	58	15	29	$4_{-0.015}^{-0.004}$	14	0.5	9	$9_{-0.036}^0$	3	12	9.8	M5 x 0.8	3.6	19.8	14.6	24
15	34	67	20	29	$5_{-0.016}^{-0.004}$	18	0.5	10	$12_{-0.043}^0$	4	14	14.3	M5 x 0.8	7.6	24	17.1	29

Size	Q	W	Y
10	M3 x 0.5 depth 6	35	18.5
15	M3 x 0.5 depth 5	35	18.5

Model Selection

CRB

CRB□-A

CRB□-B/CRB□-C

Component Unit

Auto Switch Mounting

CRB□-A Series

Dimensions: With Vertical Auto Switch Unit (10, 15)

CRBW-A (For 270°)

• Following figures show the position of the ports during rotation.

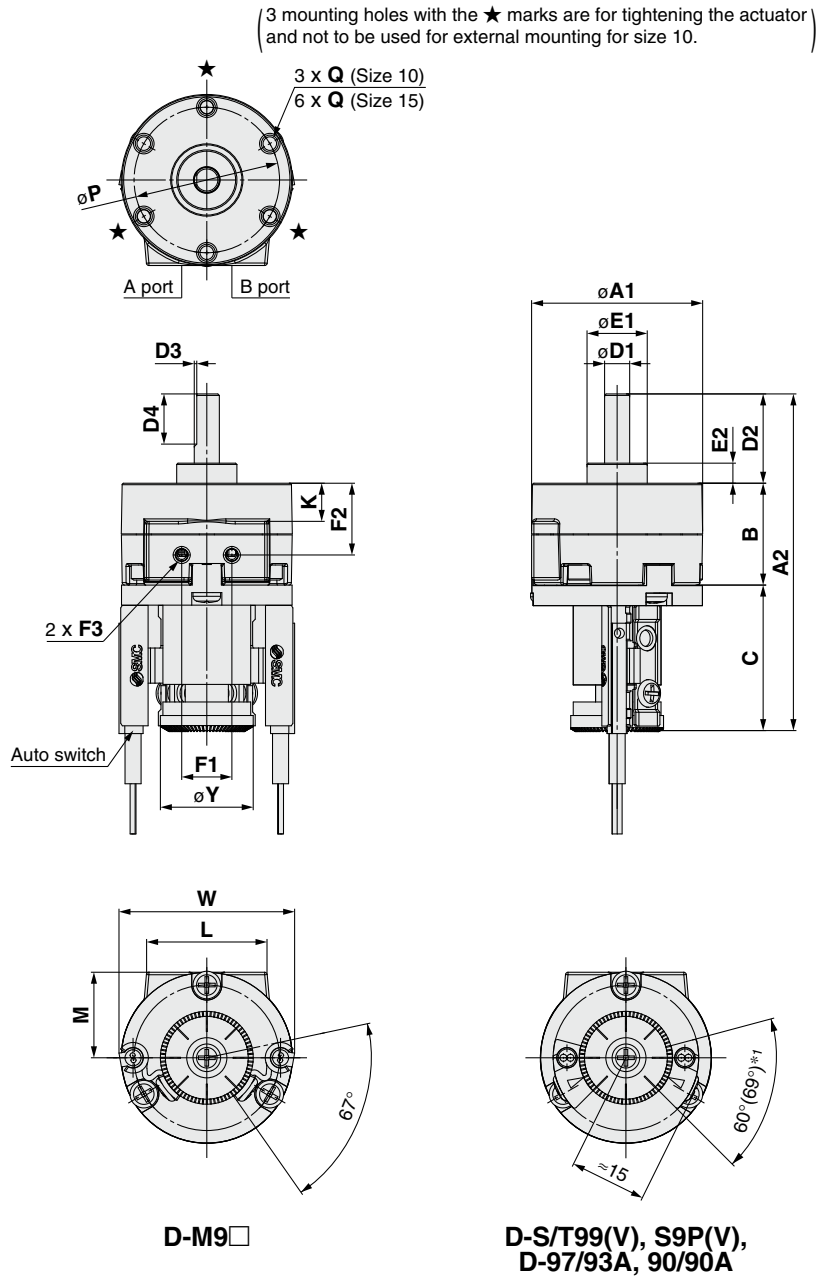

*1 The angle is 60° when any of the following are used: D-90/90A/97/93A
The angle is 69° when any of the following are used: D-S99(V)/T99(V)/S9P(V)

Size	A		B	C	D				E		F			K	L	M	P
	A1	A2			D1(g7)	D2	D3	D4	E1(h9)	E2	F1	F2	F3				
10	29	58	15	29	4 ^{-0.004} _{-0.015}	14	0.5	9	9 ⁰ _{-0.036}	3	9.5	9.8	M3 x 0.5	3.6	19.8	14.6	24
15	34	67	20	29	5 ^{-0.004} _{-0.016}	18	0.5	10	12 ⁰ _{-0.043}	4	10	14.3	M3 x 0.5	7.6	24	17.1	29

Size	Q	W	Y
10	M3 x 0.5 depth 6	35	18.5
15	M3 x 0.5 depth 5	35	18.5

Dimensions: With Vertical Auto Switch Unit (20, 30, 40)

CRBW-A (For 90° and 180°)

• Following figures show actuators when B port is pressurized.

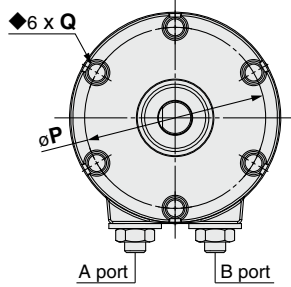

For size 40

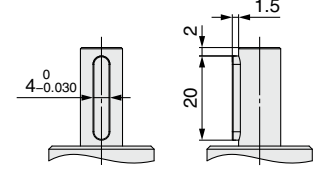

Parallel key dimensions

b(h9)	h(h9)	L1
4 ⁰ _{-0.030}	4 ⁰ _{-0.030}	20

A parallel key is used instead of a chamfer for size 40.

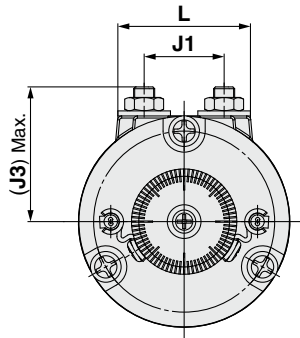
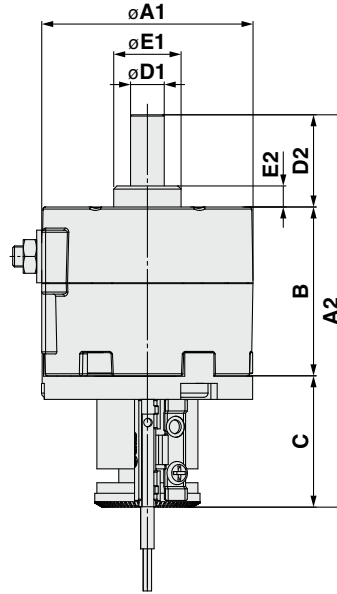
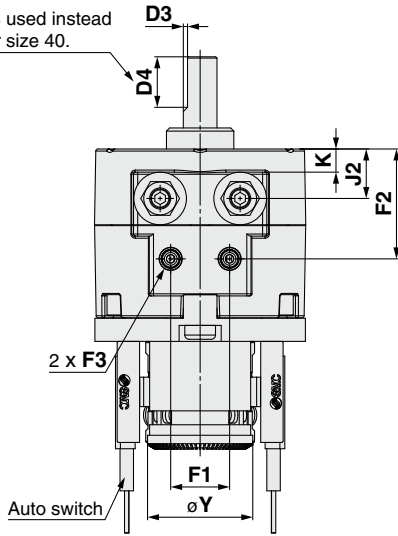

D-M9□

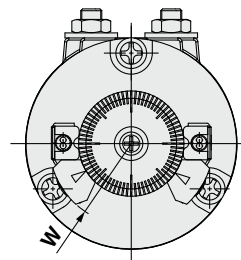

D-S/T79□, S7P, R73/80□

Size	A		B	C	D				E		F			J			K
	A1	A2			D1(g7)	D2	D3	D4	E1(h9)	E2	F1	F2	F3	J1	J2	J3	
20	42	79	29	30	6 ^{-0.004} _{-0.016}	20	0.5	10	14 ⁰ _{-0.043}	4.5	13	18.3	M5 x 0.8	16	7.1	27.4	—
30	50	93	40	31	8 ^{-0.005} _{-0.020}	22	1	12	16 ⁰ _{-0.043}	5	14	26	M5 x 0.8	19	11.8	32.7	5.5
40	63	106	45	31	10 ^{-0.005} _{-0.020}	30	—	—	25 ⁰ _{-0.052}	6.5	20	31.1	M5 x 0.8	28	15.8	44.1	9.5

Size	L	P	Q	W	Y
20	28	36	M4 x 0.7 depth 7	19.5	25
30	31.5	43	M5 x 0.8 depth 10	19.5	25
40	40	56	M5 x 0.8 depth 10	22.5	31

Model Selection

CRB

CRB□-A

CRB□-B/CRB□-C

Component Unit

Auto Switch Mounting

CRB□-A Series

Dimensions: With Vertical Auto Switch Unit (20, 30, 40)

CRBW-A (For 270°)

• Following figures show the position of the ports during rotation.

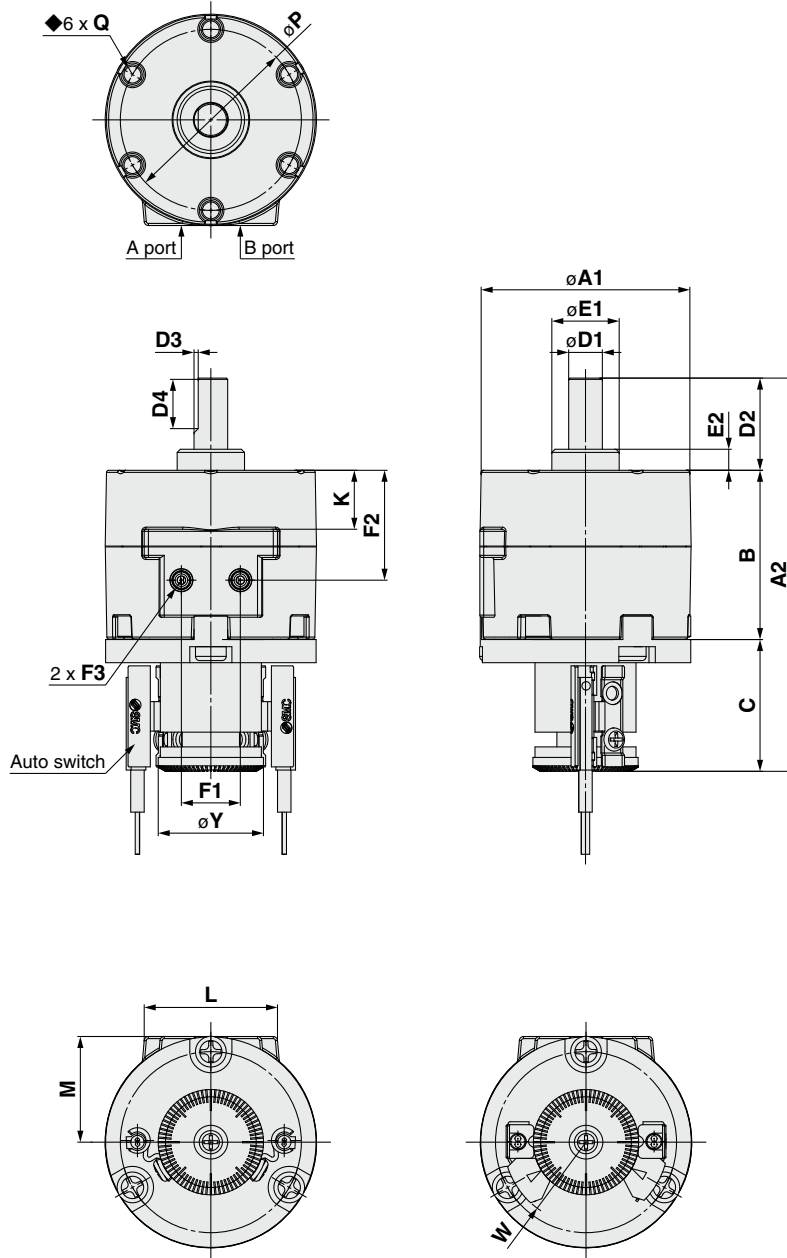

For size 40

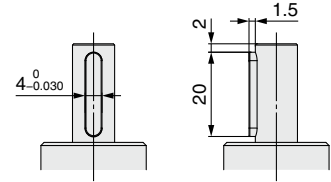

Parallel key dimensions

b(h9)	h(h9)	L1
4_{-0.030}^0	4_{-0.030}^0	20

Size	A		B	C	D				E		F		
	A1	A2			D1(g7)	D2	D3	D4	E1(h9)	E2	F1	F2	F3
20	42	79	29	30	6 ^{-0.004} _{-0.016}	20	0.5	10	14 ⁰ _{-0.043}	4.5	13	18.3	M5 x 0.8
30	50	93	40	31	8 ^{-0.005} _{-0.020}	22	1	12	16 ⁰ _{-0.043}	5	14	26	M5 x 0.8
40	63	106	45	31	10 ^{-0.005} _{-0.020}	30	—	—	25 ⁰ _{-0.052}	6.5	20	31.1	M5 x 0.8

Size	K	L	M	P	Q	W	Y
20	10.5	28	21	36	M4 x 0.7 depth 7	19.5	25
30	14	31.5	25	43	M5 x 0.8 depth 10	19.5	25
40	17	40	31.6	56	M5 x 0.8 depth 10	22.5	31

Vane Type Rotary Actuator

With Angle Adjustment Unit/With Vertical Auto Switch Unit and Angle Adjustment Unit

CRB□-B/CRB□-C Series

Size: 10, 15, 20, 30, 40

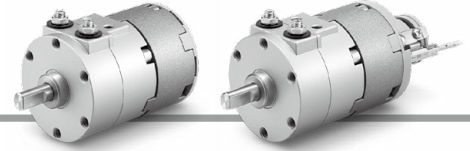

How to Order

With angle adjustment unit

CRB **W** **30** - **90** - **B**

With vertical auto switch unit and angle adjustment unit

CRB **W** **30** - **90** - **M9B** **L** □ - **CM**

1 Shaft type

Symbol	Shaft type	Shaft-end shape	
		Long shaft	Short shaft
W	Double shaft	Single flat*1	Single flat*3
J *2	Double shaft	Round shaft	Single flat*3

- *1 Size 40 has a parallel key instead of a chamfered portion.
- *2 Option "J" is produced upon receipt of order.
- *3 An angle adjustment unit can be mounted to the short shaft side.

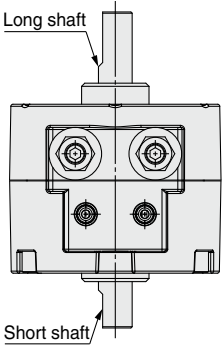

2 Size

10
15
20
30
40

3 Rotating angle

90	90°
180	180°
270	270°

5 Lead wire length

Nil	Grommet/Lead wire: 0.5 m
M	Grommet/Lead wire: 1 m
L	Grommet/Lead wire: 3 m
CN	Connector/Without lead wire
C	Connector/Lead wire: 0.5 m
CL	Connector/Lead wire: 3 m
Z *1	Grommet/Lead wire: 5 m

- *1 The 5 m lead wire is produced upon receipt of order.
- * Connectors are only available for the R73, R80, and T79.
- * Lead wire with connector part nos.
D-LC05: Lead wire 0.5 m
D-LC30: Lead wire 3 m
D-LC50: Lead wire 5 m

4 Auto switch

- * For applicable auto switches, refer to the table below.

6 Number of auto switches

Nil	2
S	1

7 With vertical auto switch unit and angle adjustment unit

Symbol	Description	Applicable auto switch
C	With vertical auto switch unit and angle adjustment unit (Built-in magnet)	Other than the D-M9□(V) → Refer to pages 49 and 50.
CM	With vertical auto switch unit for the D-M9 and angle adjustment unit (Built-in magnet)	D-M9□(V) → Refer to page 48.

- * Refer to page 46 if either unit is needed separately.

Applicable Auto Switches/Refer to the Web Catalog for further information on auto switches.

Applicable size	Type	Special function	Electrical entry	Indicator/light	Wiring (Output)	Load voltage		Auto switch model		Lead wire type	Lead wire length [m]					Pre-wired connector	Applicable load	
						DC	AC	Perpendicular	In-line		0.5 (Nil)	1 (M)	3 (L)	5 (Z)	None (N)		IC circuit	Relay, PLC
For 10, 15	Solid state auto switch	—	Grommet	Yes	3-wire (NPN)	24 V	—	—	—	Oilproof heavy-duty cord	●	●	●	○	○	IC circuit	Relay, PLC	
					3-wire (PNP)						●	●	●	○	○	—		
					2-wire						●	●	●	○	○	—		
	Reed auto switch	—	—	No	2-wire	5 V, 12 V	5 V, 12 V, 24 V	—	90	Vinyl parallel cord	●	—	●	●	—	—	IC circuit	Relay, PLC
						12 V	5 V, 12 V, 24 V, 100 V	—	90A	Oilproof heavy-duty cord	●	—	●	●	—	—	—	
						12 V	—	—	97	Vinyl parallel cord	●	—	●	●	—	—	—	
For 20, 30, 40	Solid state auto switch	—	Grommet	Yes	3-wire (NPN)	24 V	—	—	—	Oilproof heavy-duty cord	●	●	●	○	○	IC circuit	Relay, PLC	
					3-wire (PNP)						●	●	●	○	○	—		
					2-wire						●	●	●	○	○	—		
			3-wire (NPN)	●	—						●	○	○	—	—	—		
			3-wire (PNP)	●	—						●	○	○	—	—	—		
			2-wire	●	—						●	○	○	—	—	—		
	Reed auto switch	—	Connector	Yes	2-wire	—	100 V	—	R73	—	●	—	●	●	—	—	—	
						Grommet	—	—	R73C	—	●	—	●	●	—	—	—	
						Connector	—	—	R80	—	●	—	●	○	—	—	IC circuit	
			Grommet	No	—	—	48 V, 100 V	100 V	—	R80	—	●	—	●	●	—	—	—
							—	24 V or less	—	R80C	—	●	—	●	●	—	—	—
							—	—	—	—	—	●	—	●	●	—	—	—

- * Auto switches are shipped together with the product but do not come assembled.
- * Auto switches marked with a "○" are produced upon receipt of order.

Model Selection

CRB

CRB□-A

CRB□-B/CRB□-C

Component Unit

Auto Switch Mounting

CRB□-B/CRB□-C Series

Rotating Angle with Angle Adjustment Unit

- Drawings below are viewed from the long shaft side.
- The position of the chamfered portion illustrates the conditions of actuators when B port is pressurized.
- Operate within the adjustment range.

Rotating angle with angle adjustment unit

Size: 10, 15

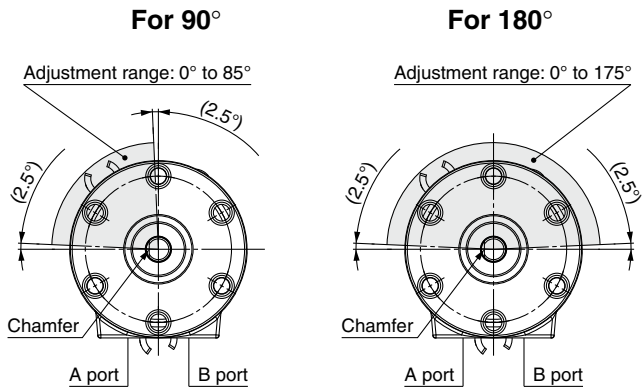

The shaded area shows the rotation adjustment range.

Size: 20, 30, 40

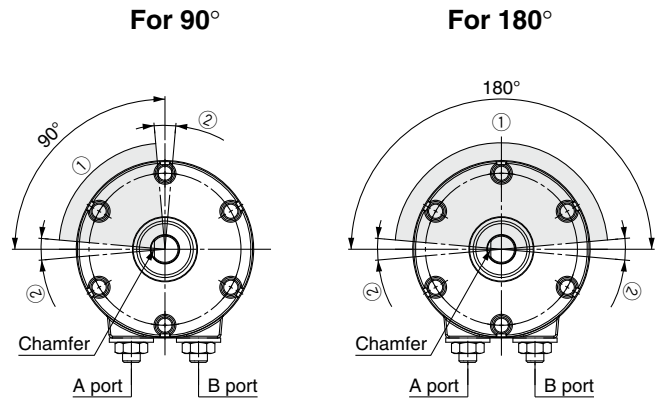

The shaded area shows the rotation adjustment range.

Rotating Angle with Angle Adjustment Unit

Rotating angle (Body)	Size	
	10	15
90°	0 to 85°	
180°	0 to 175°	

	Adjustment range	For 90°	For 180°
①	Angle adjustment unit	0° to 80°	0° to 170°
②	Adjustment bolt	90°±10° (One side ±5°)	180°±10° (One side ±5°)

Size: 10, 40

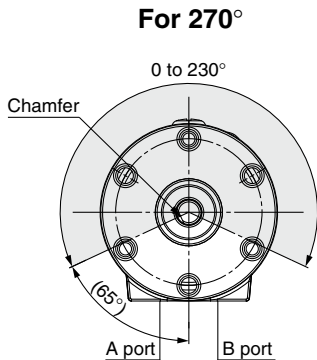

Size: 15, 20, 30

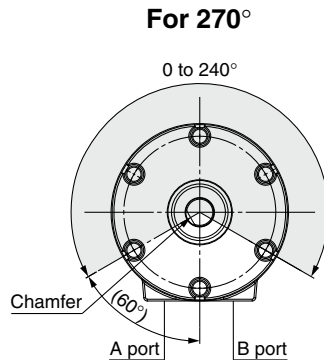

Rotating Angle Adjustment Method

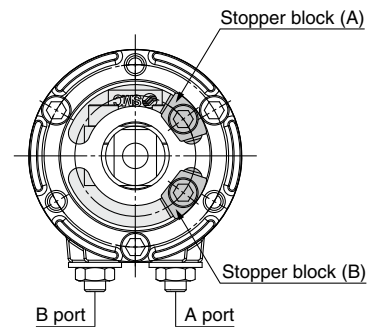

Fig. 1 Default position

- The rotating angle can be adjusted by moving the stopper blocks (A) and (B) shown in Fig. 1.
- Fig. 1 shows the default position of the angle adjustment unit.
- Fig. 1 shows size 20.
- * Make adjustments when pressure is not being applied.

Specifications, inner volume, and effective output are the same as those of the standard type. (→ p. 16, 17)

Weight

Size	[g]														
	10			15			20			30			40		
Rotating angle	90°	180°	270°	90°	180°	270°	90°	180°	270°	90°	180°	270°	90°	180°	270°
Basic type	27	26	26	47	46	46	110	107	106	203	197	195	378	360	366
Vertical auto switch unit	15			20			28			38			43		
Angle adjustment unit	30			47			90			150			203		

A flange mounting bracket assembly is available as an option. For details, refer to page 45.

Construction: With Angle Adjustment Unit, With Vertical Auto Switch Unit and Angle Adjustment Unit

• Components other than those specified below are the same as those of the standard type.

With angle adjustment unit

Size: 10, 15, 20, 30, 40

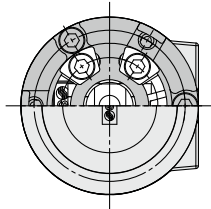
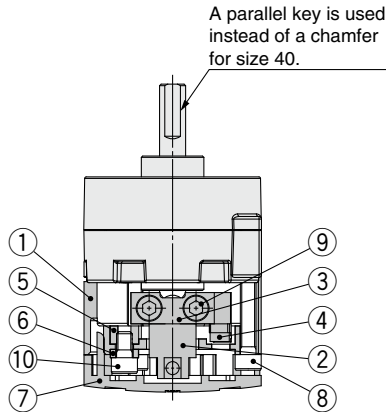

With vertical auto switch unit and angle adjustment unit

Size: 10, 15

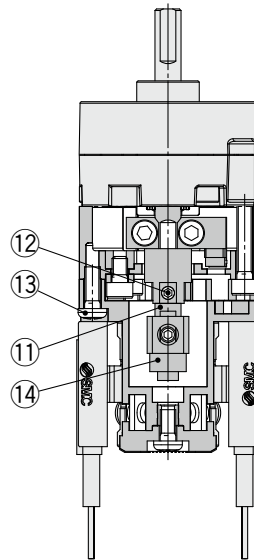

Size: 10

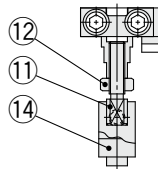

Size: 20, 30, 40

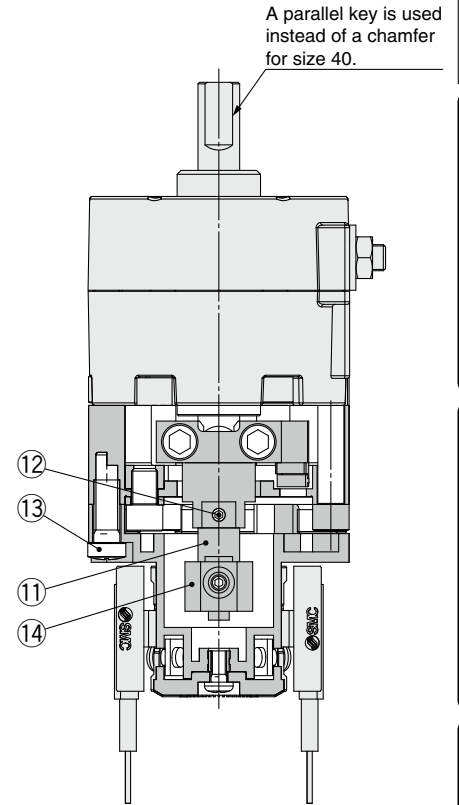

Component Parts

No.	Description	Material	Note
1	Stopper ring	Aluminum alloy	
2	Stopper lever	Chrome molybdenum steel	
3	Lever retainer	Rolled steel	Zinc chromating
4	Rubber bumper	NBR	
5	Stopper block	Chrome molybdenum steel	Zinc chromating
6	Block retainer	Rolled steel	Zinc chromating
7	Cap	Resin	
8	Hexagon socket head cap screw	Stainless steel	Special screw
9	Hexagon socket head cap screw	Stainless steel	Special screw
10	Hexagon socket head cap screw	Stainless steel	Special screw
11	Joint		
12	Hexagon socket set screw	Stainless steel	Hexagon nut will be used for size 10 only.
	Hexagon nut	Stainless steel	
13	Cross recessed round head screw	Stainless steel	
14	Magnet lever	—	

Model Selection

CRB

CRB□-A

CRB□-B/CRB□-C

Component Unit

Auto Switch Mounting

CRB□-B Series

Dimensions: With Angle Adjustment Unit (10, 15)

CRBW-B (For 90° and 180°)

- Following figures show actuators when B port is pressurized.

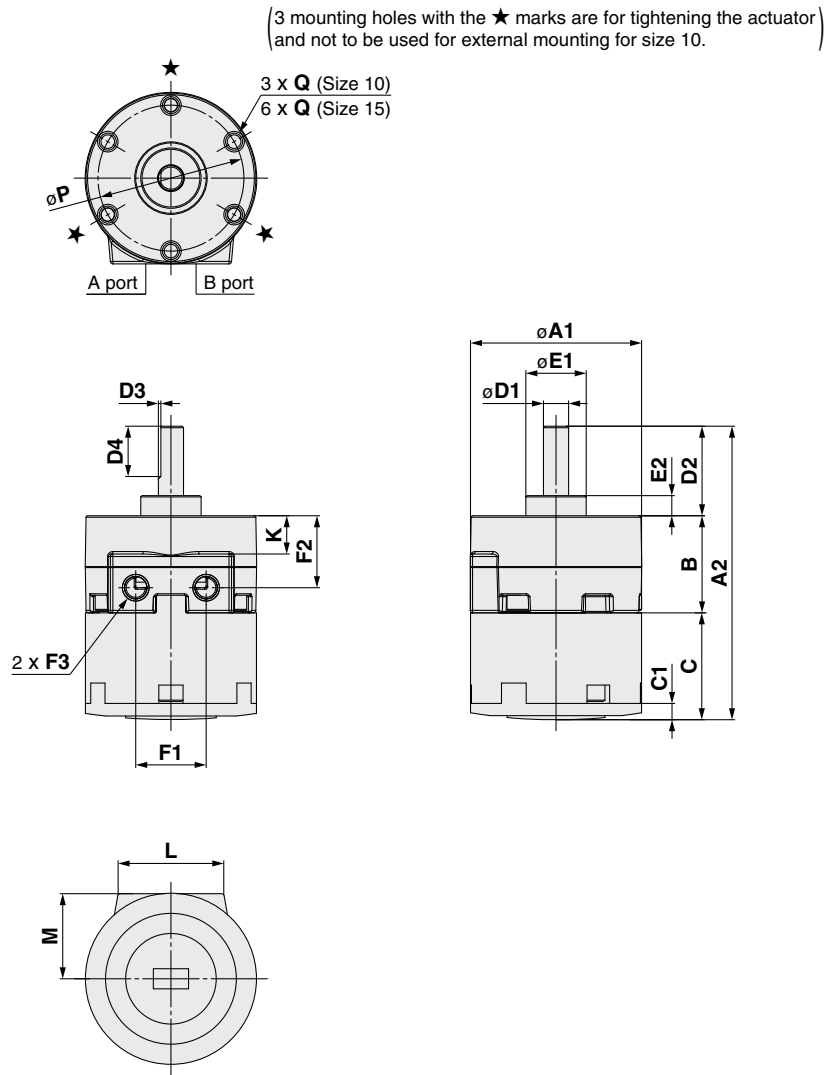

Size	A		B	C		D				E		F			K	L	M
	A1	A2		C	C1	D1(g7)	D2	D3	D4	E1(h9)	E2	F1	F2	F3			
10	29	48.5	15	19.5	3	$4_{-0.015}^{-0.004}$	14	0.5	9	$9_{-0.036}^0$	3	12	9.8	M5 x 0.8	3.6	19.8	14.6
15	34	59	20	21	3	$5_{-0.016}^{-0.004}$	18	0.5	10	$12_{-0.043}^0$	4	14	14.3	M5 x 0.8	7.6	24	17.1

Size	P	Q
10	24	M3 x 0.5 depth 6
15	29	M3 x 0.5 depth 5

Dimensions: With Angle Adjustment Unit (10, 15)

CRBW-B (For 270°)

• Following figures show the position of the ports during rotation.

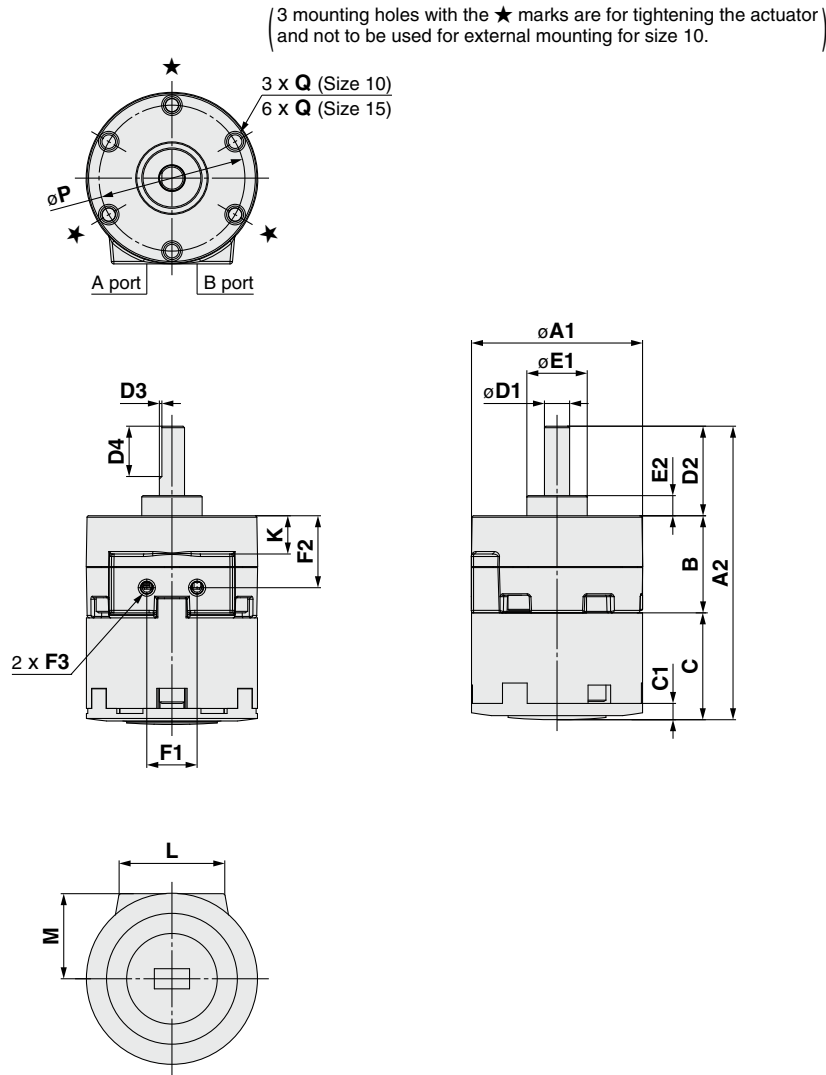

Size	A		B	C		D				E		F			K	L	M
	A1	A2		C	C1	D1(g7)	D2	D3	D4	E1(h9)	E2	F1	F2	F3			
10	29	48.5	15	19.5	3	$4_{-0.015}^{-0.004}$	14	0.5	9	$9_{-0.036}^0$	3	9.5	9.8	M3 x 0.5	3.6	19.8	14.6
15	34	59	20	21	3	$5_{-0.016}^{-0.004}$	18	0.5	10	$12_{-0.043}^0$	4	10	14.3	M3 x 0.5	7.6	24	17.1

Size	P	Q
10	24	M3 x 0.5 depth 6
15	29	M3 x 0.5 depth 5

Model Selection

CRB

CRB□-A

CRB□-B/CRB□-C

Component Unit

Auto Switch Mounting

CRB□-B Series

Dimensions: With Angle Adjustment Unit (20, 30, 40)

CRBW-B (For 90° and 180°)

• Following figures show actuators when B port is pressurized.

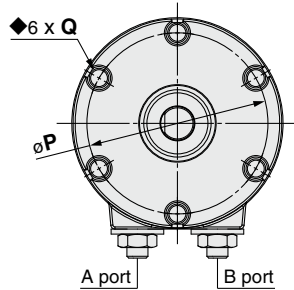

For size 40

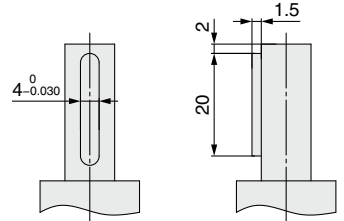

Parallel key dimensions

b(h9)	h(h9)	L1
4 ⁰ _{-0.030}	4 ⁰ _{-0.030}	20

A parallel key is used instead of a chamfer for size 40.

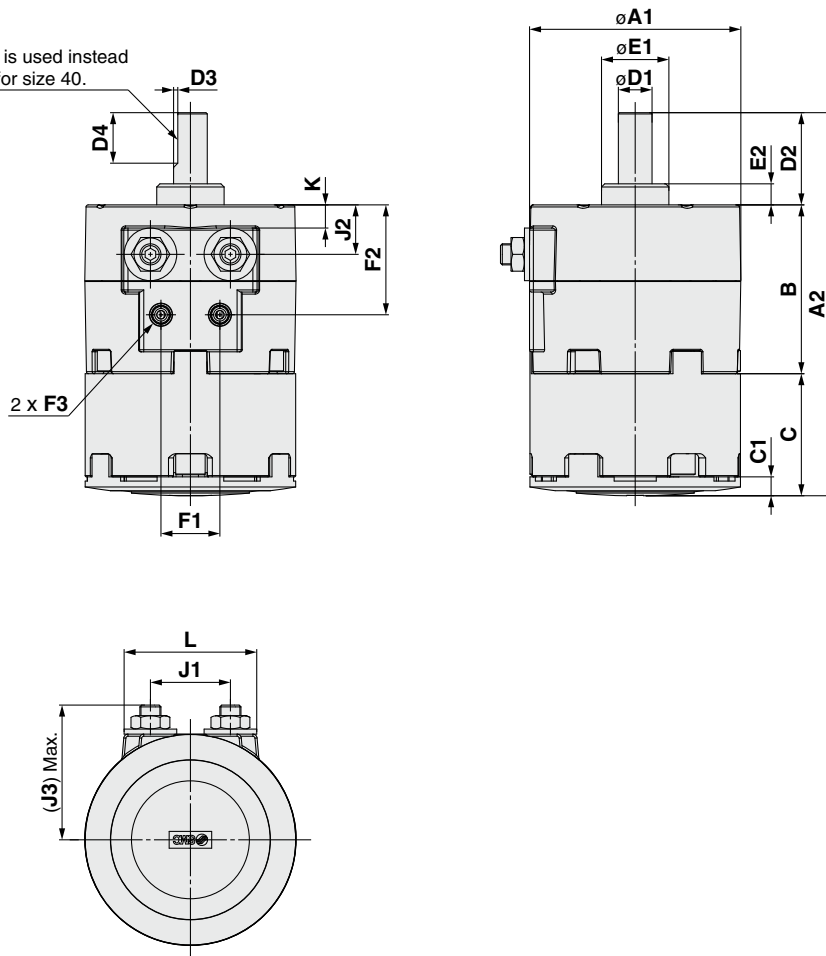

Size	A		B	C		D				E		F			J		
	A1	A2		C	C1	D1(g7)	D2	D3	D4	E1(h9)	E2	F1	F2	F3	J1	J2	J3
20	42	74	29	25	4	6 ^{-0.004} _{-0.016}	20	0.5	10	14 ⁰ _{-0.043}	4.5	13	18.3	M5 x 0.8	16	7.1	27.4
30	50	91	40	29	4.5	8 ^{-0.005} _{-0.020}	22	1	12	16 ⁰ _{-0.043}	5	14	26	M5 x 0.8	19	11.8	32.7
40	63	111.3	45	36.3	5	10 ^{-0.005} _{-0.020}	30	—	—	25 ⁰ _{-0.052}	6.5	20	31.1	M5 x 0.8	28	15.8	44.1

Size	K	L	P	Q
20	—	28	36	M4 x 0.7 depth 7
30	5.5	31.5	43	M5 x 0.8 depth 10
40	9.5	40	56	M5 x 0.8 depth 10

Dimensions: With Angle Adjustment Unit (20, 30, 40)

CRBW-B (For 270°)

• Following figures show the position of the ports during rotation.

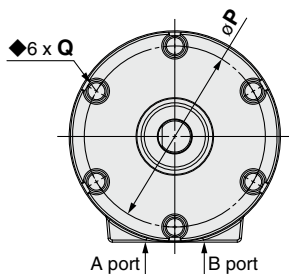

For size 40

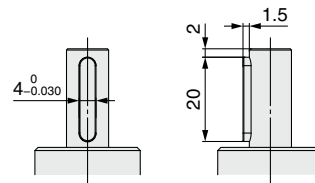

Parallel key dimensions

b(h9)	h(h9)	L1
$4_{-0.030}^0$	$4_{-0.030}^0$	20

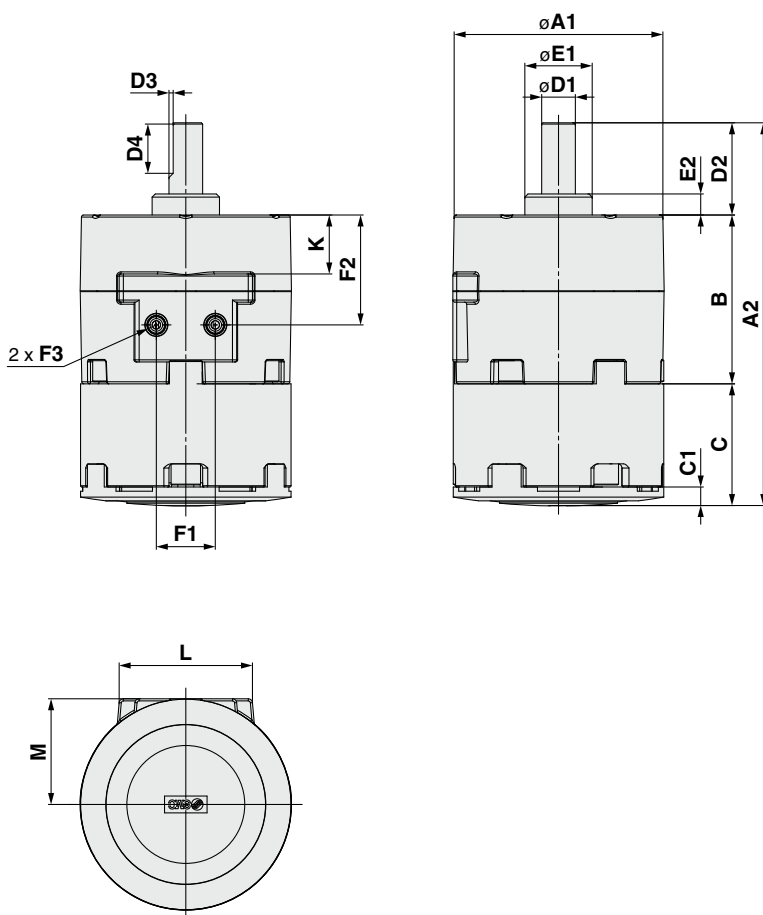

Size	A		B	C		D				E		F		
	A1	A2		C	C1	D1(g7)	D2	D3	D4	E1(h9)	E2	F1	F2	F3
20	42	74	29	25	4	$6_{-0.016}^{-0.004}$	20	0.5	10	$14_{-0.043}^0$	4.5	13	18.3	M5 x 0.8
30	50	91	40	29	4.5	$8_{-0.020}^{-0.005}$	22	1	12	$16_{-0.043}^0$	5	14	26	M5 x 0.8
40	63	111.3	45	36.3	5	$10_{-0.020}^{-0.005}$	30	—	—	$25_{-0.052}^0$	6.5	20	31.1	M5 x 0.8

Size	K	L	M	P	Q
20	10.5	28	21	36	M4 x 0.7 depth 7
30	14	31.5	25	43	M5 x 0.8 depth 10
40	17	40	31.6	56	M5 x 0.8 depth 10

Model Selection
CRB
CRB□-A
CRB□-B/CRB□-C
Component Unit
Auto Switch Mounting

CRB□-C Series

Dimensions: With Vertical Auto Switch Unit and Angle Adjustment Unit (10, 15)

CRBW-C (For 90° and 180°)

• Following figures show actuators when B port is pressurized.

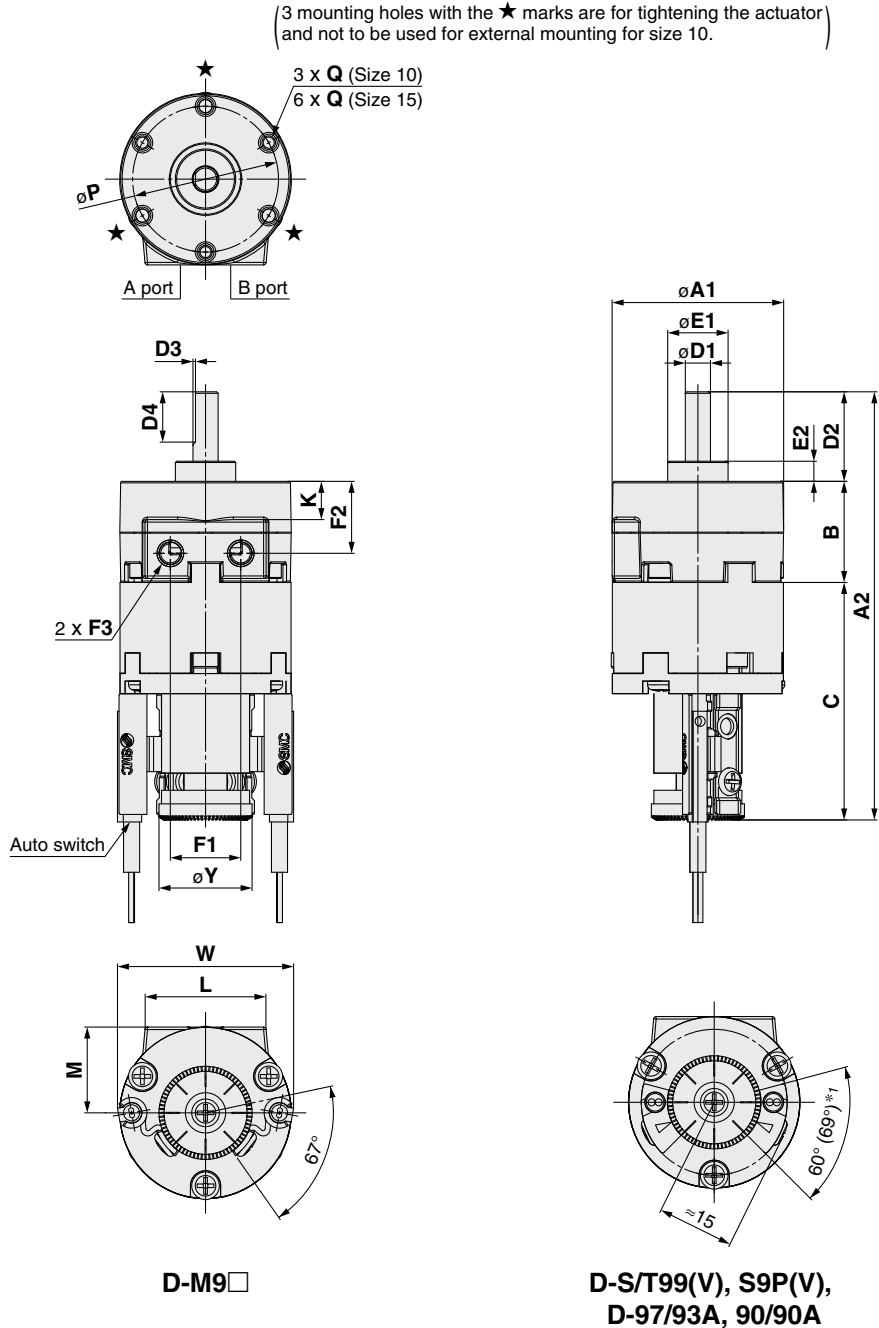

*1 The angle is 60° when any of the following are used: D-90/90A/97/93A
The angle is 69° when any of the following are used: D-S99(V)/T99(V)/S9P(V)

Size	A		B	C	D				E		F			K	L
	A1	A2			D1(g7)	D2	D3	D4	E1(h9)	E2	F1	F2	F3		
10	29	74.5	15	45.5	4 ^{-0.004} _{-0.015}	14	0.5	9	9 ⁰ _{-0.036}	3	12	9.8	M5 x 0.8	3.6	19.8
15	34	85	20	47	5 ^{-0.004} _{-0.016}	18	0.5	10	12 ⁰ _{-0.043}	4	14	14.3	M5 x 0.8	7.6	24

Size	M	P	Q	W	Y
10	14.6	24	M3 x 0.5 depth 6	35	18.5
15	17.1	29	M3 x 0.5 depth 5	35	18.5

Dimensions: With Vertical Auto Switch Unit and Angle Adjustment Unit (10, 15)

CRBW-C (For 270°)

• Following figures show the position of the ports during rotation.

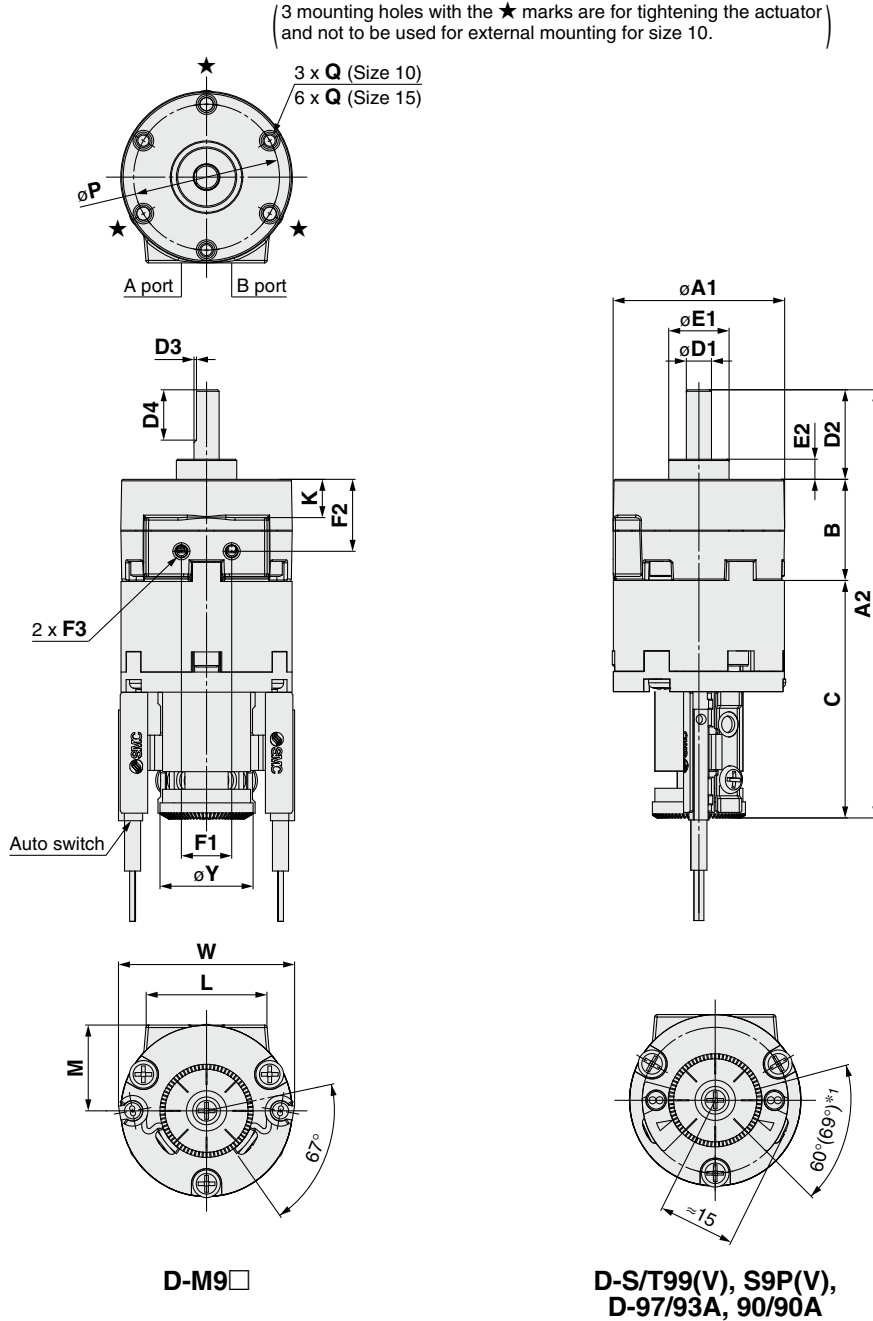

*1 The angle is 60° when any of the following are used: D-90/90A/97/93A
The angle is 69° when any of the following are used: D-S99(V)/T99(V)/S9P(V)

Size	A		B	C	D				E		F			K	L
	A1	A2			D1(g7)	D2	D3	D4	E1(h9)	E2	F1	F2	F3		
10	29	74.5	15	45.5	4 ^{-0.004} _{-0.015}	14	0.5	9	9 ⁰ _{-0.036}	3	9.5	9.8	M3 x 0.5	3.6	19.8
15	34	85	20	47	5 ^{-0.004} _{-0.016}	18	0.5	10	12 ⁰ _{-0.043}	4	10	14.3	M3 x 0.5	7.6	24

Size	M	P	Q	W	Y
10	14.6	24	M3 x 0.5 depth 6	35	18.5
15	17.1	29	M3 x 0.5 depth 5	35	18.5

Model Selection

CRB

CRB□-A

CRB□-B/CRB□-C

Component Unit

Auto Switch Mounting

CRB□-C Series

Dimensions: With Vertical Auto Switch Unit and Angle Adjustment Unit (20, 30, 40)

CRBW-C (For 90° and 180°)

• Following figures show actuators when B port is pressurized.

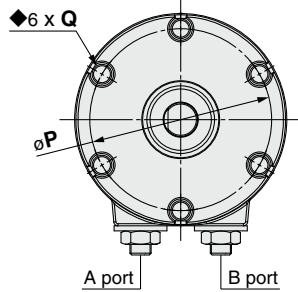

For size 40

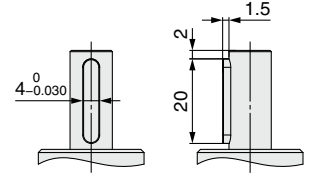

A parallel key is used instead of a chamfer for size 40.

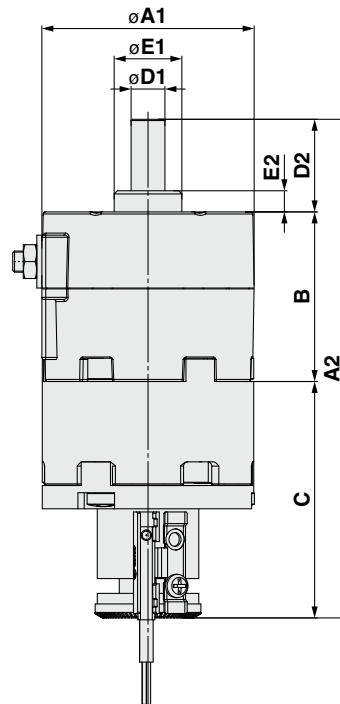
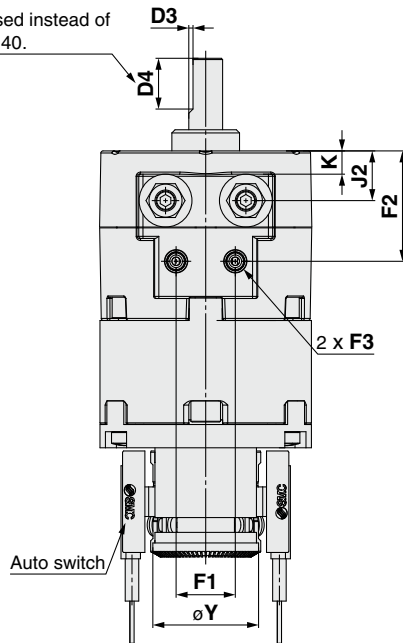

Parallel key dimensions

b(h9)	h(h9)	L1
4 ⁰ _{-0.030}	4 ⁰ _{-0.030}	20

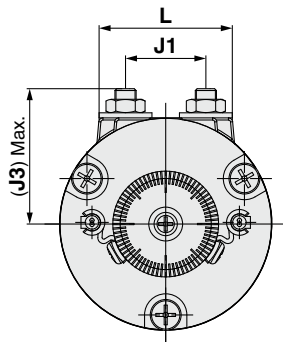

D-M9□

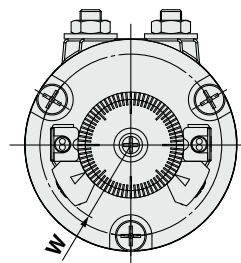

D-S/T79□, S7P, R73/80□

Size	A		B	C	D				E		F			J			K	L	P	Q	W	Y
	A1	A2			D1(g7)	D2	D3	D4	E1(h9)	E2	F1	F2	F3	J1	J2	J3						
20	42	100	29	51	6 ^{-0.004} _{-0.016}	20	0.5	10	14 ⁰ _{-0.043}	4.5	13	18.3	M5 x 0.8	16	7.1	27.4	—	28	36	M4 x 0.7 depth 7	19.5	25
30	50	117.5	40	55.5	8 ^{-0.005} _{-0.020}	22	1	12	16 ⁰ _{-0.043}	5	14	26	M5 x 0.8	19	11.8	32.7	5.5	31.5	43	M5 x 0.8 depth 10	19.5	25
40	63	137.2	45	62.2	10 ^{-0.005} _{-0.020}	30	—	—	25 ⁰ _{-0.052}	6.5	20	31.1	M5 x 0.8	28	15.8	44.1	9.5	40	56	M5 x 0.8 depth 10	22.5	31

Dimensions: With Vertical Auto Switch Unit and Angle Adjustment Unit (20, 30, 40)

CRBW-C (For 270°)

• Following figures show the position of the ports during rotation.

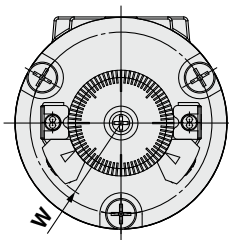
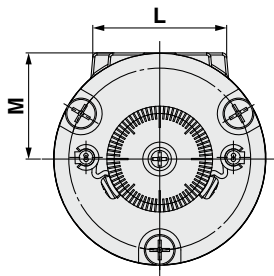
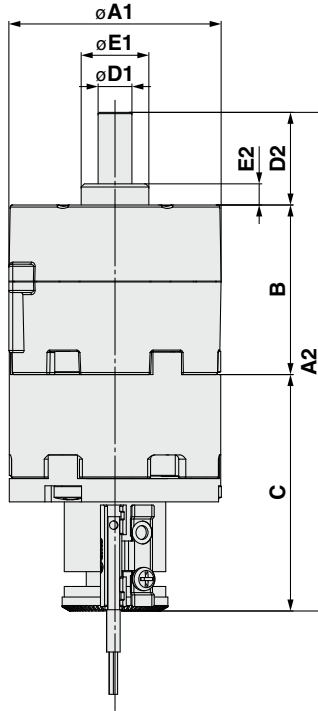
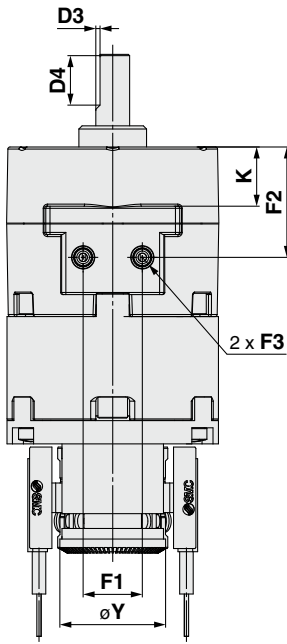
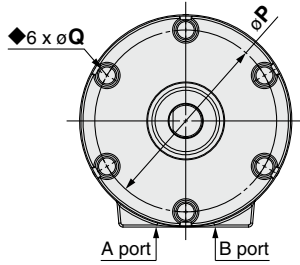

For size 40

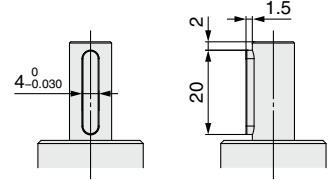

Parallel key dimensions

b(h9)	h(h9)	L1
4 ⁰ _{-0.030}	4 ⁰ _{-0.030}	20

Size	A		B	C	D				E		F		
	A1	A2			D1(g7)	D2	D3	D4	E1(h9)	E2	F1	F2	F3
20	42	100	29	51	6 ^{0.004} _{-0.016}	20	0.5	10	14 ⁰ _{-0.043}	4.5	13	18.3	M5 x 0.8
30	50	117.5	40	55.5	8 ^{0.005} _{-0.020}	22	1	12	16 ⁰ _{-0.043}	5	14	26	M5 x 0.8
40	63	137.2	45	62.2	10 ^{0.005} _{-0.020}	30	—	—	25 ⁰ _{-0.052}	6.5	20	31.1	M5 x 0.8

Size	K	L	M	P	Q	W	Y
20	10.5	28	21	36	M4 x 0.7 depth 7	19.5	25
30	14	31.5	25	43	M5 x 0.8 depth 10	19.5	25
40	17	31.5	31.6	56	M5 x 0.8 depth 10	22.5	31

Model Selection

CRB

CRB□-A

CRB□-B/CRB□-C

Component Unit

Auto Switch Mounting

CRB Series

Flange Dimensions/Part Nos.



Flange assembly for size 10
Part no.: P211070-2

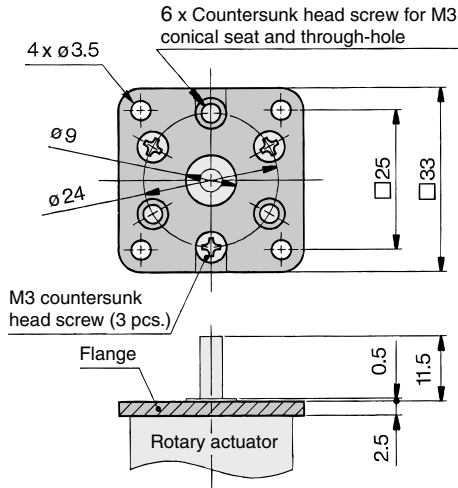

Flange assembly for size 15
Part no.: P211090-2

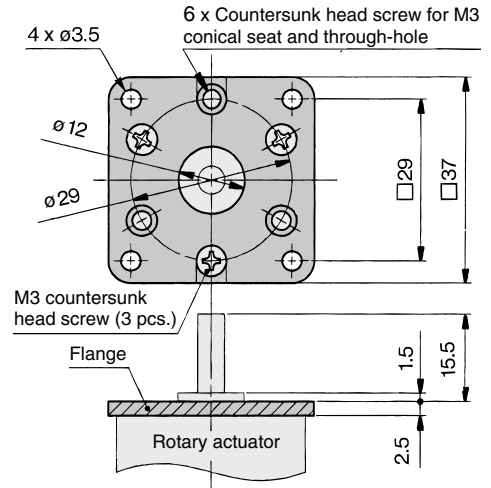

Flange assembly for size 20
Part no.: P211060-2

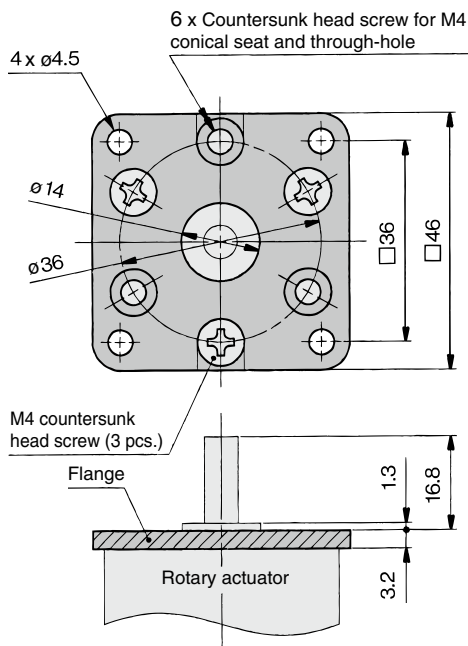

Flange assembly for size 30
Part no.: P211080-2

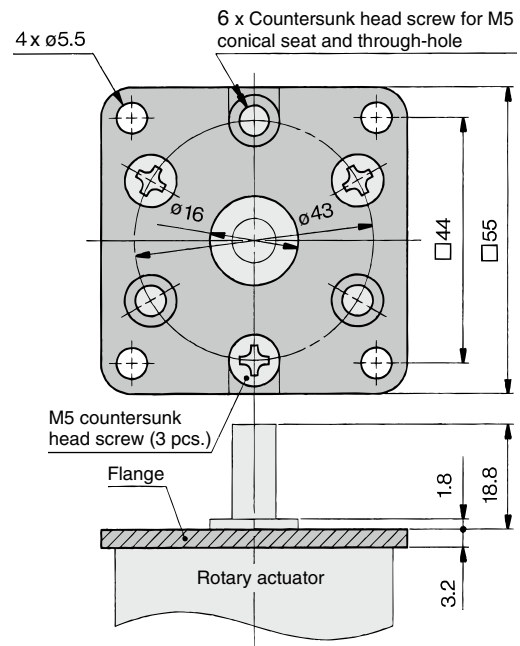

Weight

Size	10	15	20	30
Flange assembly	9	10	19	25

[g]

CRB Series

Component Unit

With Vertical Auto Switch Unit, Angle Adjustment Unit

With Vertical Auto Switch Unit and Angle Adjustment Unit

CRB Series Various units can be mounted to a vane type rotary actuator.

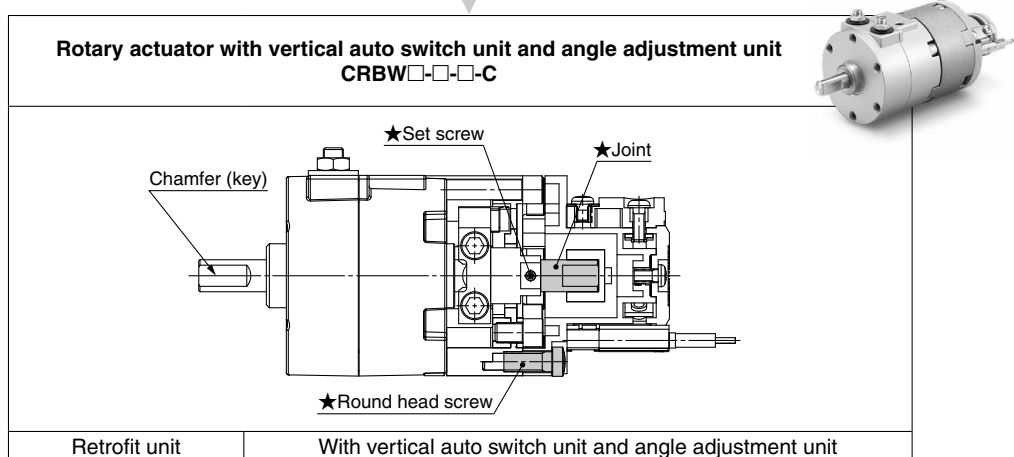
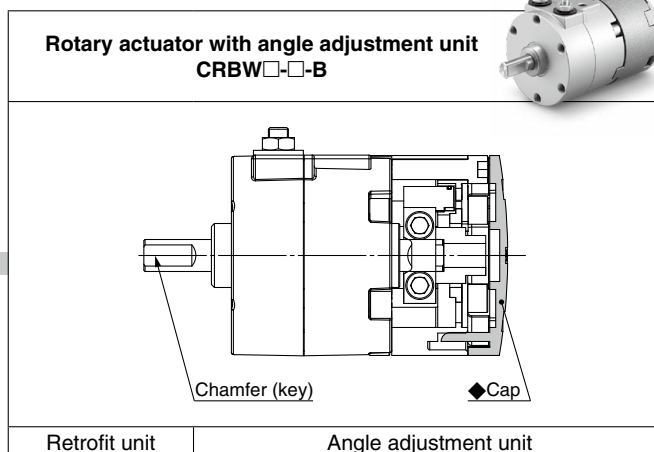
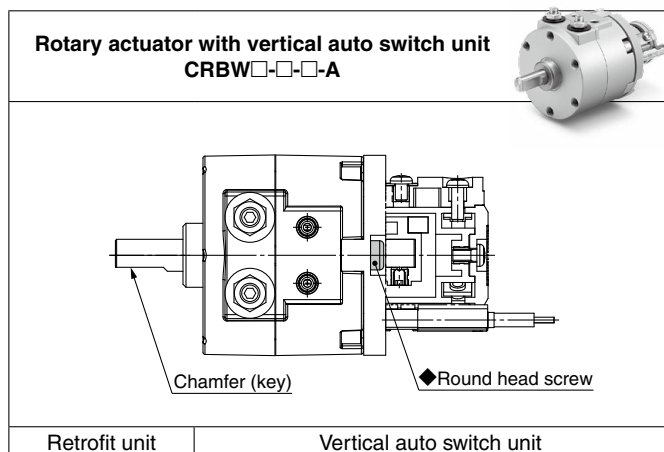

- * The combination of the auto switch unit and angle adjustment unit is available as standard.
The items marked with ★ are additional parts required for connection (joint unit parts), and the items marked with ◆ are unnecessary.
- * Use a unit part number when ordering joint unit separately.

Part Number for Vertical Auto Switch Unit

Size	For D-M9□		Excluding D-M9□		
	Vertical auto switch unit*1	Switch block unit	Vertical auto switch unit	Switch block unit*2	
		Common to right-hand and left-hand		Right-hand	Left-hand
10	P611070-1M	P811010-8M	P611070-1	P611070-8	P611070-9
15	P611090-1M		P611090-1		
20	P611060-1M	P811030-8M	P611060-1	P611060-8	
30	P611080-1M		P611080-1		
40	P611010-1M	P811010-8M	P611010-1	P611010-8	P611010-9

Part Number for Angle Adjustment Unit

Size	Angle adjustment unit	Vertical auto switch unit, Angle adjustment unit*1		Joint unit*3
		For D-M9□	Excluding D-M9□	
		10	P811010-3	
15	P811020-3	P811020-4M	P811020-4	P211090-10
20	P811030-3	P811030-4M	P811030-4	P211060-10
30	P811040-3	P811040-4M	P811040-4	P211080-10
40	P811050-3	P811050-4M	P811050-4	P211010-10

- *1 An auto switch will not be included, please order it separately.
- *2 Auto switch unit comes with one right-hand and one left-hand switch blocks that are used for addition or when the switch block is damaged.
Since the solid state auto switch for sizes 10 and 15 requires no switch block, the unit part number will be the P211070-13.
- *3 The joint unit is necessary when adding an angle adjustment unit to a vertical auto switch unit, or when adding a vertical auto switch unit to an angle adjustment unit.

CRB Series Auto Switch Mounting

Auto Switch Proper Mounting Position (at Rotation End Detection)

CDRB10, 15
Size: 10, 15

CDRB20, 30
Size: 20, 30, 40

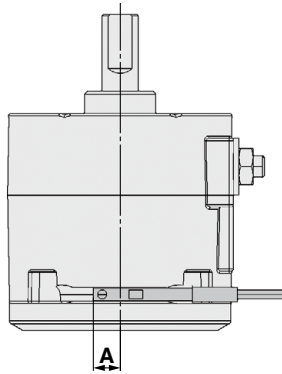
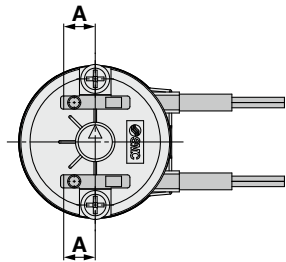

[mm]

Size	Solid state auto switch	
	D-M9□	
	A	
10	6	
15	6	
20	6	
30	6	
40	6	

* Since the figures in the table on the left are provided as a guideline only, they cannot be guaranteed. Adjust the auto switch after confirming the operating conditions in the actual setting.

Proper tightening torque: 0.05 to 0.15 [N·m]

Operating Angle and Hysteresis Angle

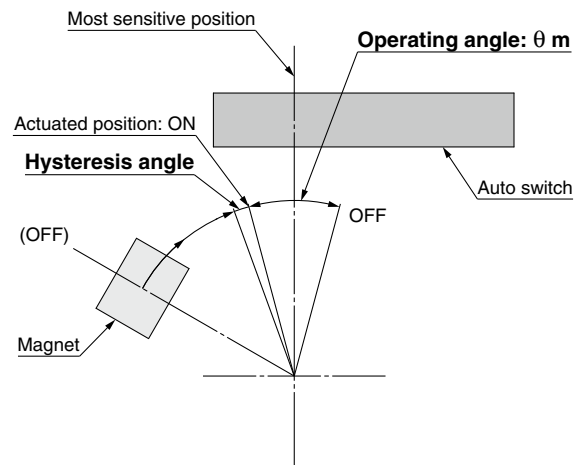

Size	Solid state auto switch	
	D-M9□	
	Operating angle [θ m]	Hysteresis angle
10	36°	5°
15	36°	5°
20	20°	5°
30	20°	5°
40	20°	5°

* Since the figures in the table on the left are provided as a guideline only, they cannot be guaranteed. Adjust the auto switch after confirming the operating conditions in the actual setting.

Proper tightening torque: 0.05 to 0.15 [N·m]

Operating Range and Hysteresis

* Operating range: θ m

The range is between the position where the auto switch turns ON as the magnet inside the auto switch unit moves rotationally and the position where the auto switch turns OFF as the magnet moves rotationally in the same direction.

* Hysteresis range: θ d

The range is between the position where the auto switch turns ON as the magnet inside the auto switch unit moves rotationally and the position where the auto switch turns OFF as the magnet moves rotationally in the opposite direction.

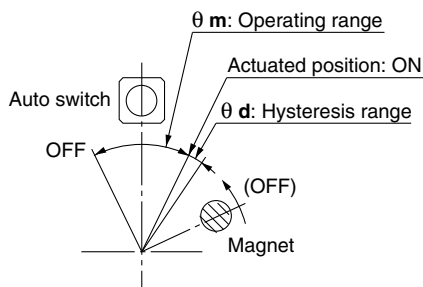

D-M9□

Size	θ m: Operating range	θ d: Hysteresis range
10, 15	170°	20°
20, 30	100°	15°
40	86°	10°

D-S/T99(V), S9P(V), S/T79□, S7P, D-97/93A, 90/90A, R73/80□

Size	θ m: Operating range	θ d: Hysteresis range
10, 15	110°	10°
20, 30	90°	
40	52°	8°

* Since the figures in the table above are provided as a guideline only, they cannot be guaranteed. Adjust the auto switch after confirming the operating conditions in the actual setting.

How to Change the Auto Switch Detecting Position

* When setting the detecting position, loosen the cross recessed round head screw a bit and move the auto switch to the preferred position and then tighten again and fix it. At this time, if tightened too much, screw can become damaged and unable to fix position.

Proper tightening torque: 0.4 to 0.6 [N·m]

When tightening the cross recessed round head screw, take care that the auto switch does not tilt.

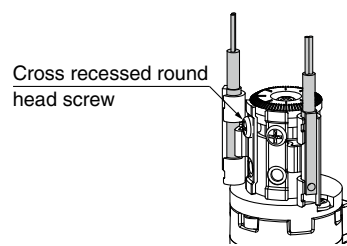

Size: 10 to 40
D-M9□

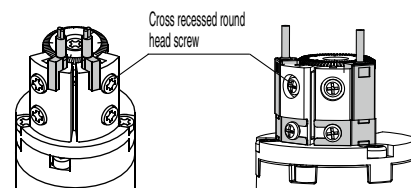

Size: 10, 15

Size: 20 to 40

D-S/T99(V), S9P(V), S/T79□, S7P,
D-97/93A, 90/90A, R73/80□

Auto Switch Mounting: Sizes 10 to 40 (D-M9□)

External view and descriptions of auto switch unit

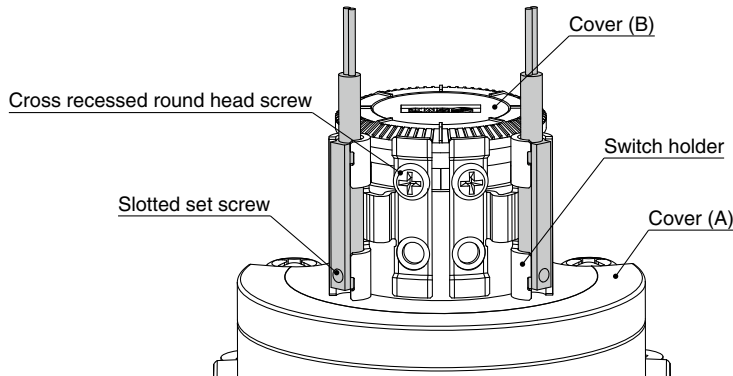

For sizes 10, 15

1. Auto switch mounting

Insert the auto switch into the groove of the switch holder.

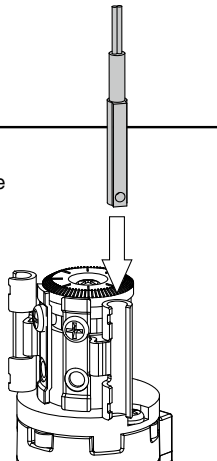

2. Auto switch securing

Align the auto switch with the upper surface of the groove on the side of the switch holder, and secure the slotted set screw. (Refer to the enlarged view.)

* Proper tightening torque: 0.05 to 0.1 [N·m]

Align with the groove upper surface to secure.

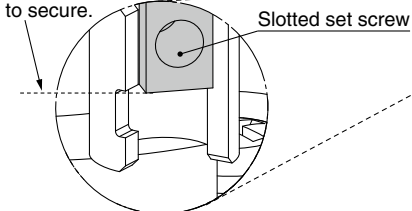

Enlarged view

3. Switch holder securing

After the actuated position has been adjusted with the cross recessed round head screw, use the auto switch.

* When tightening the screw, take care that the auto switch does not tilt.

For sizes 20 to 40

1. Auto switch mounting

Insert the auto switch into the groove of the switch holder.

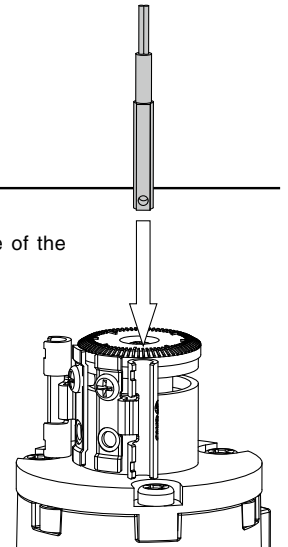

2. Auto switch securing

Align the auto switch with the lower surface of the groove on the side of the switch holder, and secure the slotted set screw. (Refer to the enlarged view.)

* Proper tightening torque: 0.05 to 0.1 [N·m]

Align with the groove lower surface to secure.

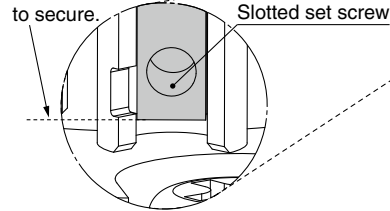

Enlarged view

3. Switch holder securing

After the actuated position has been adjusted with the cross recessed round head screw, use the auto switch.

* When tightening the screw, take care that the auto switch does not tilt.

Model Selection

CRB

CRB□-A

CRB□-B/CRB□-C

Component Unit

Auto Switch Mounting

CRB□-A/C Series

Auto Switch Mounting: Sizes 10, 15 (D-S/T99(V), S9P(V), 97/93A, 90/90A)

External view and descriptions of auto switch unit

The following shows the external view and typical descriptions of the auto switch unit.

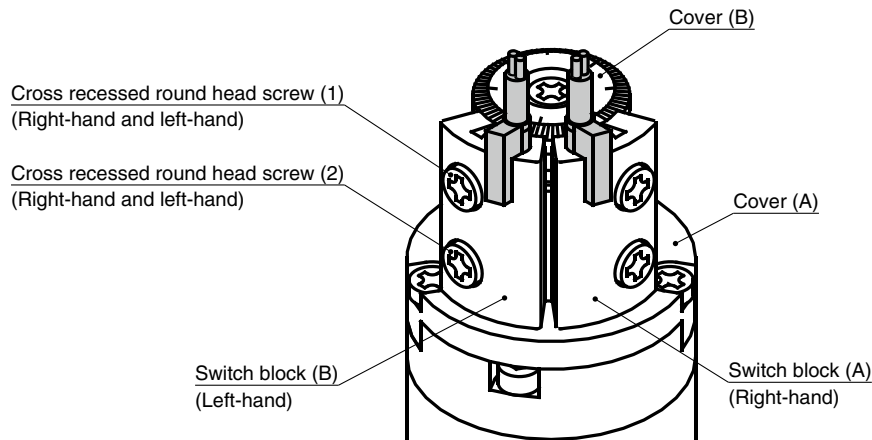

Solid state auto switch

<Applicable auto switch>

3-wire type.....D-S99(V), S9P(V)

2-wire type.....D-T99(V)

1. Switch block detaching

Remove the cross recessed round head screw (1) to detach the switch block.

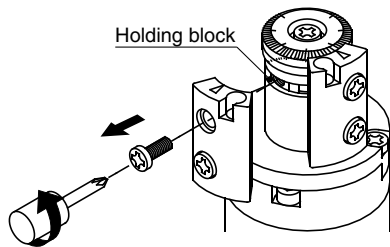

2. Auto switch mounting

Secure the auto switch with the cross recessed round head screw (1) and holding block.

Proper tightening torque: 0.4 to 0.6 [N·m]

* Since the holding block moves inside the groove, move it to the mounting position beforehand.

· After the actuated position has been adjusted with the cross recessed round head screw (1), use the auto switch.

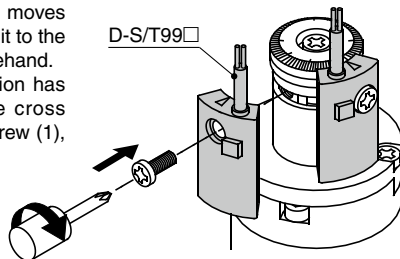

Reed auto switch

<Applicable auto switch>

D-97/93A (With indicator light)

D-90/90A (Without indicator light)

1. Preparations

Loosen the cross recessed round head screw (2) (About 2 to 3 turns).

* This screw has been secured temporarily at shipment.

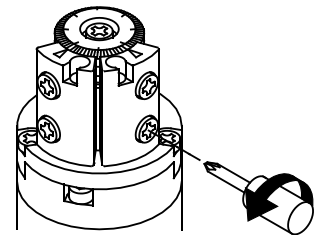

2. Auto switch mounting

Insert the auto switch until it is in contact with the switch block hole.

* For the D-97/93A, insert the auto switch in the direction shown in the figure on the right.

* Since the D-90/90A is a round type, it has no directionality.

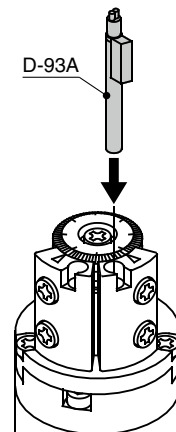

3. Auto switch securing

Tighten the cross recessed round head screw (2) to secure the auto switch.

Proper tightening torque: 0.4 to 0.6 [N·m]

· After the actuated position has been adjusted with the cross recessed round head screw (1), use the auto switch.

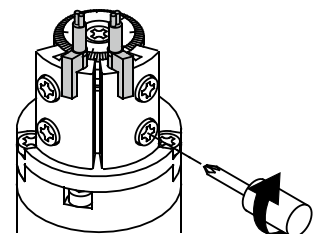

Auto Switch Mounting: Sizes 20 to 40 (D-S/T79□, S7P, R73/80□)

External view and descriptions of auto switch unit

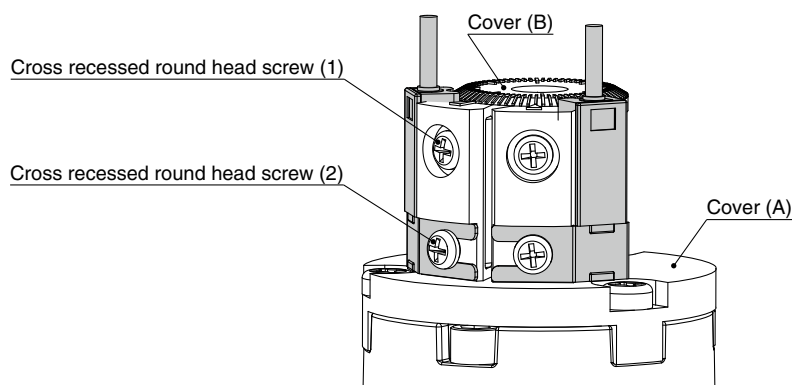

Mounting Procedure

<Applicable auto switch>

Solid state auto switch
D-S79, S7P
D-T79, T79C

Reed auto switch
D-R73, R73C
D-R80, R80C

1. Auto switch mounting

Loosen the cross recessed round head screw (2), and insert the arm of the auto switch.

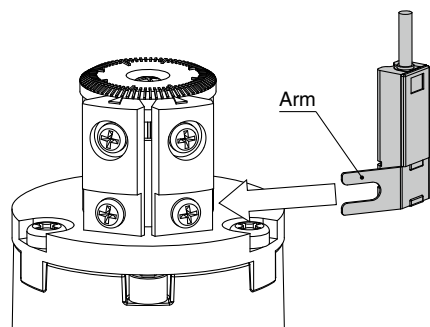

2. Auto switch securing

Set the auto switch so that it is in contact with the switch block, and tighten the cross recessed round head screw (2).

* Proper tightening torque: 0.4 to 0.6 [N·m]

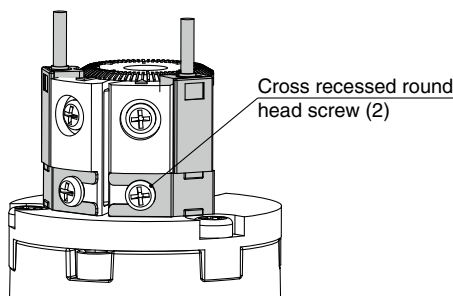

3. Switch holder securing

After the actuated position has been adjusted with the cross recessed block, and tighten the screw (1), use the auto switch.

* Proper tightening torque: 0.4 to 0.6 [N·m]

Auto Switch Adjustment

Rotation range of the output shaft with single flat (key for size 40 only) and auto switch mounting position <Applicable models/Size: 10, 15, 20, 30, 40>

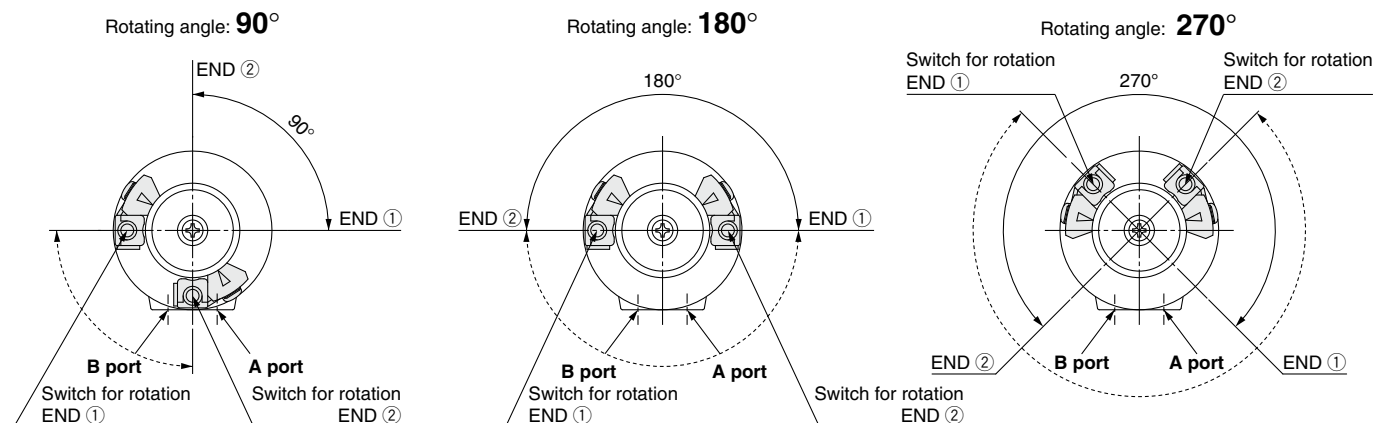

- * Solid-lined curves indicate the rotation range of the output shaft with single flat (key). When the single flat (key) is pointing to the END ① direction, the switch for rotation END ① will operate, and when the single flat (key) is pointing to the END ② direction, the switch for rotation END ② will operate.
- * Broken-lined curves indicate the rotation range of the built-in magnet. Operating angle of the switch can be decreased by either moving the switch for rotation END ① clockwise or moving the switch for rotation END ② counterclockwise. Auto switch in the figures above is at the most sensitive position.
- * Each auto switch unit comes with one right-hand and one left-hand switches.

Model Selection

CRB

CRB□-A

CRB□-B/CRB□-C

Component Unit

Auto Switch Mounting

Prior to Use

Auto Switch Connections and Examples

Sink Input Specifications

3-wire, NPN

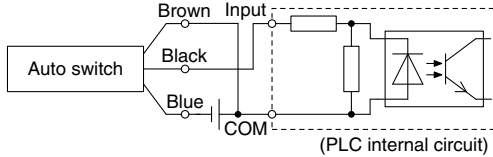

2-wire

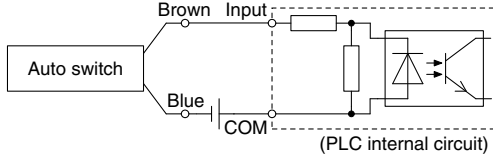

Source Input Specifications

3-wire, PNP

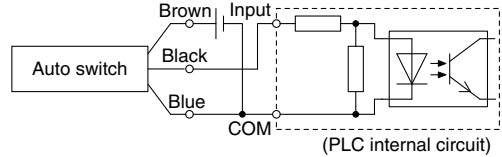

2-wire

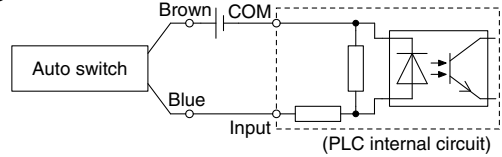

Connect according to the applicable PLC input specifications, as the connection method will vary depending on the PLC input specifications.

Examples of AND (Series) and OR (Parallel) Connections

* When using solid state auto switches, ensure the application is set up so the signals for the first 50 ms are invalid. Depending on the operating environment, the product may not operate properly.

3-wire AND connection for NPN output (Using relays)

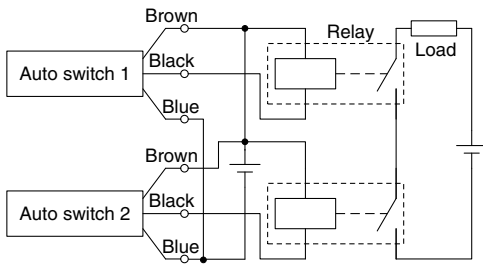

(Performed with auto switches only)

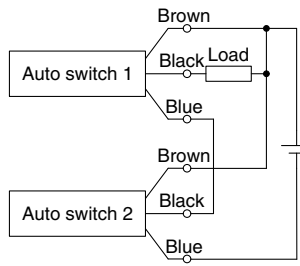

3-wire OR connection for NPN output

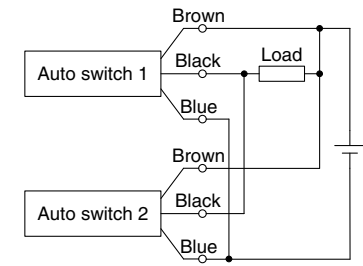

3-wire AND connection for PNP output (Using relays)

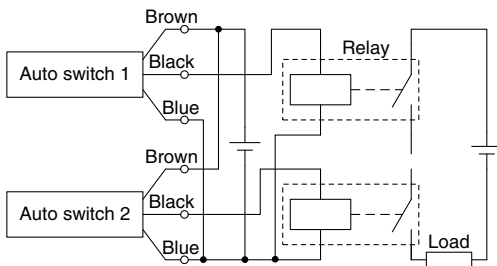

(Performed with auto switches only)

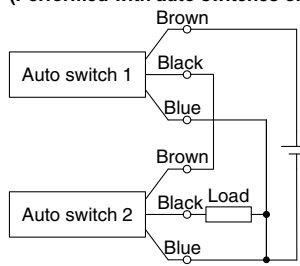

3-wire OR connection for PNP output

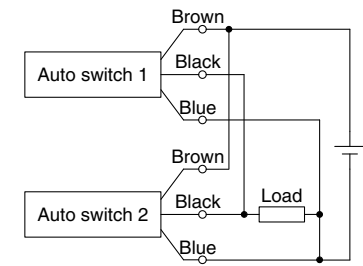

2-wire AND connection

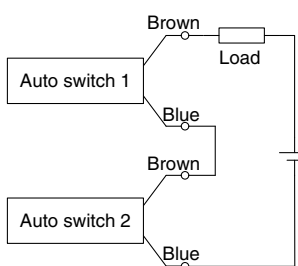

When two auto switches are connected in series, a load may malfunction because the load voltage will decline when in the ON state. The indicator lights will light up when both of the auto switches are in the ON state. Auto switches with a load voltage less than 20 V cannot be used. Please contact SMC if using AND connection for a heat-resistant solid state auto switch or a trimmer switch.

Example) Load voltage at ON
 Power supply voltage: 24 VDC
 Internal voltage drop: 4 V
 Load voltage at ON = Power supply voltage –
 Internal voltage drop x 2 pcs.
 = 24 V – 4 V x 2 pcs.
 = 16 V

2-wire OR connection

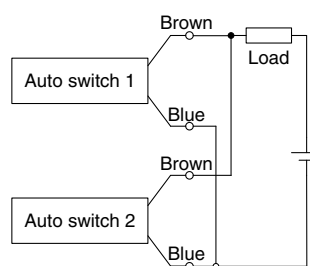

(Solid state)
 When two auto switches are connected in parallel, malfunction may occur because the load voltage will increase when in the OFF state.

(Reed)
 Because there is no current leakage, the load voltage will not increase when turned OFF. However, depending on the number of auto switches in the ON state, the indicator lights may sometimes grow dim or not light up, due to the dispersion and reduction of the current flowing to the auto switches.

Example) Load voltage at OFF
 Leakage current: 1 mA
 Load impedance: 3 kΩ
 Load voltage at OFF = Leakage current x 2 pcs. x
 Load impedance
 = 1 mA x 2 pcs. x 3 kΩ
 = 6 V



CRB Series Specific Product Precautions

Be sure to read this before handling the products. Refer to the back cover for safety instructions. For rotary actuator and auto switch precautions, refer to the "Handling Precautions for SMC Products" and the "Operation Manual" on the SMC website.

How to Mount Loads

How to connect a load directly to a single flat shaft

To secure the load, select a bolt of an appropriate size from those listed in tables 1 and 2 by taking the shaft's single flat bearing stress strength into consideration.

Table 1 Directly Fixed with Bolts (Refer to Fig. 1.)

Size	Shaft dia.	Bolt size
10	4	M4 or larger
15	5	M5 or larger
20	6	
30	8	M6 or larger

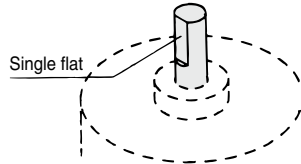
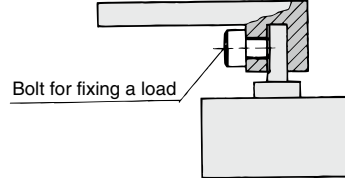

Table 2 Fixed with a Holding Block (Refer to Fig. 2.)

Size	Shaft dia.	Bolt size	Plate thickness (t)
10	4	M3 or larger	2 or wider
15	5		2.3 or wider
20	6	M4 or larger	3.6 or wider
30	8	M5 or larger	4 or wider

The plate thickness (t) in the table above indicates a reference value when a carbon steel is used. Besides, we do not manufacture a holding block.

(Fig. 1)



(Fig. 2)

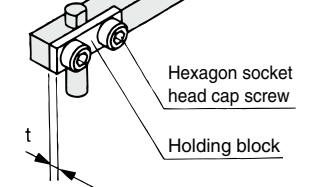

Mounting

Refer to the table below when tightening the mounting bolts.

Mounting 1

Body mounting 1 (Body tapped)

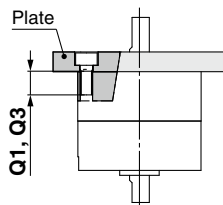

Size	Bolt	Recommended tightening torque [N·m]
10	M3	0.63
15	M3	0.63
20	M4	1.50
30	M5	3.0
40	M5	3.0

* Refer to the Dimensions for Q1 and Q3 dimensions.

Mounting 2

Body mounting 2 (Body through-hole)

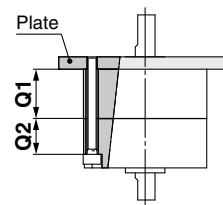

Size	Bolt	Recommended tightening torque [N·m]
10	M2.5	0.36
15	M2.5	0.36
20	M3	0.63
30	M4	1.50
40	M4	1.50

* Refer to the Dimensions for Q1 and Q2 dimensions.

* Only for standard CRB without auto switch

Adjustment

Do not apply a load when adjusting the rotating angle.

Example) For 180 degrees

1. Set the adjustment bolt B while supplying pressure from the A port.

2. Set the adjustment bolt A while supplying pressure from the B port.

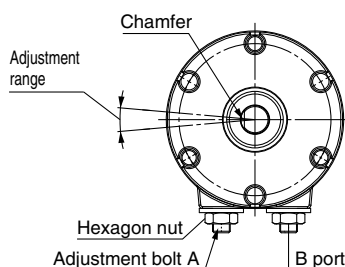
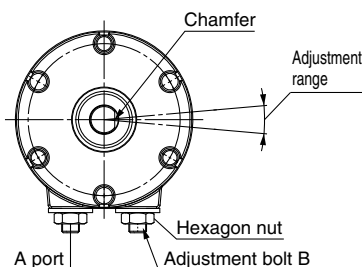



☆ Recommended tightening torque for hexagon nut to fix the adjustment bolt
Size 20: 1.5 N·m
Sizes 30, 40: 3 N·m

Safety Instructions

These safety instructions are intended to prevent hazardous situations and/or equipment damage. These instructions indicate the level of potential hazard with the labels of “**Caution**,” “**Warning**” or “**Danger**.” They are all important notes for safety and must be followed in addition to International Standards (ISO/IEC)*1), and other safety regulations.

 **Caution:** **Caution** indicates a hazard with a low level of risk which, if not avoided, could result in minor or moderate injury.

 **Warning:** **Warning** indicates a hazard with a medium level of risk which, if not avoided, could result in death or serious injury.

 **Danger :** **Danger** indicates a hazard with a high level of risk which, if not avoided, will result in death or serious injury.

*1) ISO 4414: Pneumatic fluid power – General rules relating to systems.
ISO 4413: Hydraulic fluid power – General rules relating to systems.
IEC 60204-1: Safety of machinery – Electrical equipment of machines.
(Part 1: General requirements)
ISO 10218-1: Manipulating industrial robots – Safety.
etc.

Warning

1. The compatibility of the product is the responsibility of the person who designs the equipment or decides its specifications.

Since the product specified here is used under various operating conditions, its compatibility with specific equipment must be decided by the person who designs the equipment or decides its specifications based on necessary analysis and test results. The expected performance and safety assurance of the equipment will be the responsibility of the person who has determined its compatibility with the product. This person should also continuously review all specifications of the product referring to its latest catalog information, with a view to giving due consideration to any possibility of equipment failure when configuring the equipment.

2. Only personnel with appropriate training should operate machinery and equipment.

The product specified here may become unsafe if handled incorrectly. The assembly, operation and maintenance of machines or equipment including our products must be performed by an operator who is appropriately trained and experienced.

3. Do not service or attempt to remove product and machinery/equipment until safety is confirmed.

1. The inspection and maintenance of machinery/equipment should only be performed after measures to prevent falling or runaway of the driven objects have been confirmed.
2. When the product is to be removed, confirm that the safety measures as mentioned above are implemented and the power from any appropriate source is cut, and read and understand the specific product precautions of all relevant products carefully.
3. Before machinery/equipment is restarted, take measures to prevent unexpected operation and malfunction.

4. Contact SMC beforehand and take special consideration of safety measures if the product is to be used in any of the following conditions.

1. Conditions and environments outside of the given specifications, or use outdoors or in a place exposed to direct sunlight.
2. Installation on equipment in conjunction with atomic energy, railways, air navigation, space, shipping, vehicles, military, medical treatment, combustion and recreation, or equipment in contact with food and beverages, emergency stop circuits, clutch and brake circuits in press applications, safety equipment or other applications unsuitable for the standard specifications described in the product catalog.
3. An application which could have negative effects on people, property, or animals requiring special safety analysis.
4. Use in an interlock circuit, which requires the provision of double interlock for possible failure by using a mechanical protective function, and periodical checks to confirm proper operation.

Caution

1. The product is provided for use in manufacturing industries.

The product herein described is basically provided for peaceful use in manufacturing industries.
If considering using the product in other industries, consult SMC beforehand and exchange specifications or a contract if necessary.
If anything is unclear, contact your nearest sales branch.

Limited warranty and Disclaimer/ Compliance Requirements

The product used is subject to the following “Limited warranty and Disclaimer” and “Compliance Requirements”.

Read and accept them before using the product.

Limited warranty and Disclaimer

1. The warranty period of the product is 1 year in service or 1.5 years after the product is delivered, whichever is first.*2)
Also, the product may have specified durability, running distance or replacement parts. Please consult your nearest sales branch.
2. For any failure or damage reported within the warranty period which is clearly our responsibility, a replacement product or necessary parts will be provided.
This limited warranty applies only to our product independently, and not to any other damage incurred due to the failure of the product.
3. Prior to using SMC products, please read and understand the warranty terms and disclaimers noted in the specified catalog for the particular products.

*2) Vacuum pads are excluded from this 1 year warranty.

A vacuum pad is a consumable part, so it is warranted for a year after it is delivered.
Also, even within the warranty period, the wear of a product due to the use of the vacuum pad or failure due to the deterioration of rubber material are not covered by the limited warranty.

Compliance Requirements

1. The use of SMC products with production equipment for the manufacture of weapons of mass destruction (WMD) or any other weapon is strictly prohibited.
2. The exports of SMC products or technology from one country to another are governed by the relevant security laws and regulations of the countries involved in the transaction. Prior to the shipment of a SMC product to another country, assure that all local rules governing that export are known and followed.

Caution

SMC products are not intended for use as instruments for legal metrology.

Measurement instruments that SMC manufactures or sells have not been qualified by type approval tests relevant to the metrology (measurement) laws of each country. Therefore, SMC products cannot be used for business or certification ordained by the metrology (measurement) laws of each country.

Revision History

Edition B	* A 270° rotating angle specification has been added. (Size: 20, 30) * Number of pages has been increased from 48 to 52.	ZU
Edition C	* A 270° rotating angle specification has been added. (Size: 10, 15, 40) * Number of pages has been increased from 52 to 56.	AQ

Safety Instructions

Be sure to read the “Handling Precautions for SMC Products” (M-E03-3) and “Operation Manual” before use.