

Mist Separator Regulator Micro Mist Separator Regulator

New

RoHS



Transparent bowl guard

Improved environmental durability due to 2-layer construction

* Body sizes 30 and larger



Series	Size	Nominal filtration rating [μm]	Max. flow capacity [L/min (ANR)]*1	Port size
AWM	20	0.3	Up to 150	1/8, 1/4
	30		Up to 330	1/4, 3/8
	40		Up to 820	1/4, 3/8, 1/2
AWD	20	0.01	Up to 90	1/8, 1/4
	30		Up to 180	1/4, 3/8
	40		Up to 450	1/4, 3/8, 1/2

*1 Conditions/Inlet pressure: 0.7 MPa, Outlet pressure: 0.5 MPa

AWM-D/AWD-D Series



CAT.ES40-74A



Transparent bowl guard

Better environmental resistance The transparent bowl guard protects the inner bowl!

The bowl guard with windows has been replaced with a **polycarbonate transparent bowl guard**. Now, even if the environment changes and the bowl is exposed to corrosive chemical or oil splash, **the foreign matter will not come into direct contact with the pressurized bowl**. This can reduce the risk of bowl breakage.

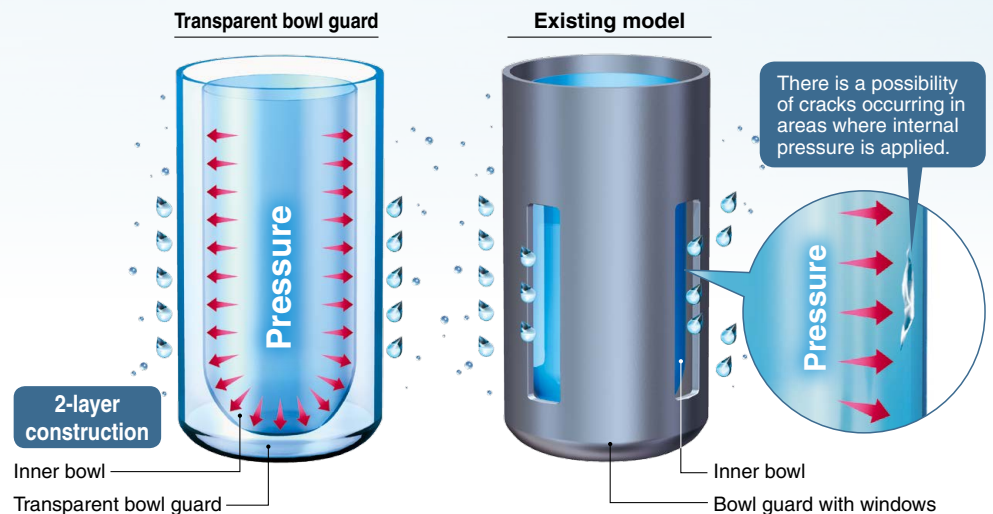

Better visibility: 360°

The transparent bowl guard allows for easy checking of the condensate level inside the filter bowl and the remaining oil amount in the lubricator from any direction.



Lightweight: Max. 40.7% reduction (0.24 kg)

Size	New AWM/AWD-D [kg]	AWM/AWD [kg]	Reduction [kg]
20	0.23	0.29	0.06 (20.7%)
30	0.35	0.59	0.24 (40.7%)
40	0.66	0.75	0.09 (12.0%)

* The values in () indicate the reduction rate.

Knob cover Option p. 11

Can be mounted on the knob in order to prevent the accidental operation of the knob



Simple Specials System



For modular connection units (shipped assembled), the simple specials system can be used.

Short lead times

This system enables us to respond to your special needs (accessory assembly or the designing of a modular unit) as quickly as standard products.

Repeat orders

Once we receive a simple special part number from one of your previous orders, we will process the order, manufacture the product, and deliver it to you as quickly as possible.

Please contact your local sales representative for more details.

Combination example ①

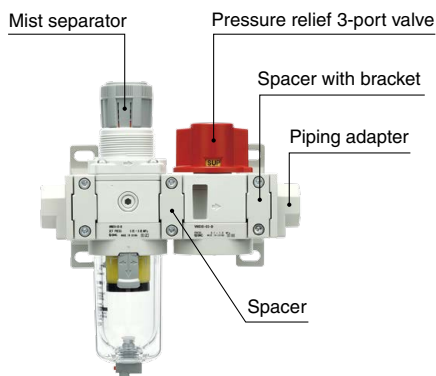

- Piping adapter E300-03-D _____ 2 pcs.
- Spacer with bracket Y300T-D _____ 2 pcs.
- Mist separator regulator AWM30-03-D _____ 1 pc.
- Spacer Y300-D _____ 1 pc.
- Pressure relief 3-port valve VHS30-03-D _____ 1 pc.

Combination example ②

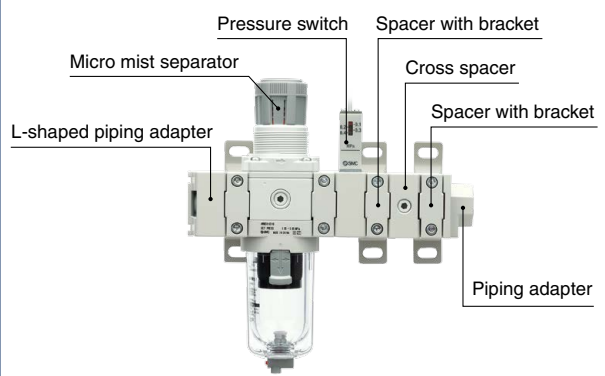

- L-shaped piping adapter E300L-03-D _____ 1 pc.
- Spacer with bracket Y300T-D _____ 3 pcs.
- Micro mist separator regulator AWD30-03-D _____ 1 pc.
- Spacer Y300-D _____ 1 pc.
- Pressure switch IS10M-30-D _____ 1 pc.
- Cross spacer Y34-03-D _____ 1 pc.
- Piping adapter E300-03-D _____ 1 pc.

Combination example ③

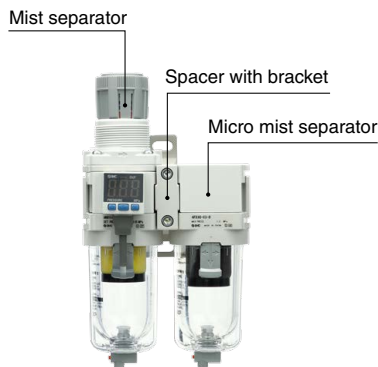

- Mist separator AWM30-03E1-D _____ 1 pc.
- Spacer with bracket Y300T-D _____ 1 pc.
- Micro mist separator AFD30-03-D _____ 1 pc.

Combination example ④

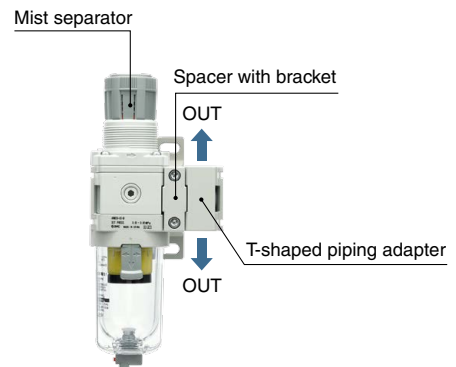

- Mist separator AWM30-03-D _____ 1 pc.
- Spacer with bracket Y300T-D _____ 1 pc.
- T-shaped piping adapter E300T-03-D _____ 1 pc.

Products do not come assembled. They should be ordered separately and assembled by the customer.

Mist Separator Regulator

AWM20-D to AWM40-D

Micro Mist Separator Regulator

AWD20-D to AWD40-D

Symbol
Mist Separator
Regulator

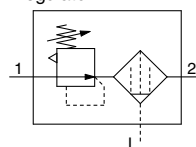

Symbol
Micro Mist Separator
Regulator

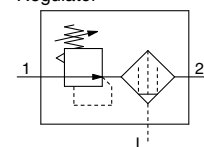

- The AWM series is made up of a regulator and a mist separator to provide optimum results in applications such as clean air blow operations. (Nominal filtration rating: 0.3 μm)
- The AWD series is made up of a regulator and a micro mist separator to provide optimum results in applications such as ultraclean air blow operations. (Nominal filtration rating: 0.01 μm)

How to Order

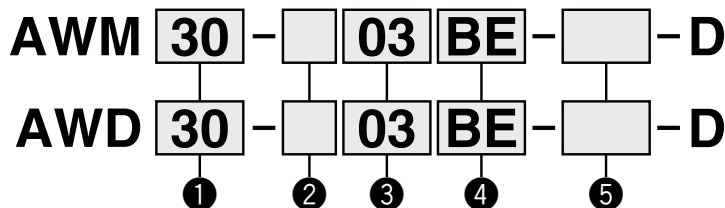

• Option/Semi-standard: Select one each for a to i.
• Option/Semi-standard symbol: When more than one specification is required, indicate in alphanumeric order.
Example) AWM30-03BE-1N-D

		Symbol	Description	①			
				Body size			
				20	30	40	
②	Pipe thread type	Nil	Rc	●	●	●	
		N	NPT	●	●	●	
		F	G	●	●	●	
		+					
③	Port size	01	1/8	●	—	—	
		02	1/4	●	●	●	
		03	3/8	—	●	●	
		04	1/2	—	—	●	
		+					
④	a	Mounting	Nil	Without mounting option	●	●	●
			B*2	With bracket	●	●	●
			H	With set nut (for panel mount)	●	●	●
			+				
	b	Float type auto drain*3	Nil	Without auto drain	●	●	●
			C*4	N.C. (Normally closed) Drain port is closed when pressure is not applied.	●	●	●
			D*5	N.O. (Normally open) Drain port is open when pressure is not applied.	—	●	●
			+				
	c	Pressure gauge*6	Nil	Without pressure gauge	●	●	●
			E	Square embedded type pressure gauge (with limit indicator)	●	●	●
			G	Round type pressure gauge (with limit indicator)	●	●	●
			M	Round type pressure gauge (with color zone)	●	●	●
Digital pressure switch*7		E1	Output: NPN output, Electrical entry: Wiring bottom entry	●	●	●	
		E2	Output: NPN output, Electrical entry: Wiring top entry	●	●	●	
		E3	Output: PNP output, Electrical entry: Wiring bottom entry	●	●	●	
E4	Output: PNP output, Electrical entry: Wiring top entry	●	●	●			
		+					
⑤	d	Set pressure*8	Nil	0.05 to 0.85 MPa setting	●	●	●
			1	0.05 to 0.2 MPa setting	●	●	●
			+				
	e	Bowl*9	Nil	Polycarbonate bowl	●	●	●
			2	Metal bowl	●	●	●
			6	Nylon bowl	●	●	●
			8	Metal bowl with level gauge	—	●	●
			C	With bowl guard	●	—*10	—*10
			6C	With bowl guard (Nylon bowl)	●	—*11	—*11
			+				
	f	Drain port*12	Nil	With drain cock	●	●	●
			J*13	Drain guide 1/8	●	—	—
			Drain guide 1/4	—	●	●	
W*14			Drain cock with barb fitting	—	●	●	

Mist Separator Regulator *AWM20-D to AWM40-D Series*

Micro Mist Separator Regulator *AWD20-D to AWD40-D Series*



AWM30-D

AWD30-D

		Symbol	Description	①			
				Body size			
				20	30	40	
⑤ Semi-standard	g	Exhaust mechanism	Nil	Relieving type	●	●	●
			N	Non-relieving type	●	●	●
	+						
	h	Flow direction	Nil	Flow direction: Left to right	●	●	●
			R	Flow direction: Right to left	●	●	●
	+						
	i	Unit	Nil	Unit on product label: MPa, °C, Pressure gauge in SI units: MPa	●	●	●
			Z*15	Unit on product label: psi, °F, Pressure gauge: MPa/psi dual scale	○*17	○*17	○*17
			ZA*16	Digital pressure switch: With unit selection function	△*18	△*18	△*18

- *1 Options B, G, H, and M are not assembled and supplied loose at the time of shipment.
- *2 The assembly consists of a bracket and set nuts.
- *3 The auto drain port is ø10 One-touch fitting (●) Pipe thread type: Rc, G) or ø3/8" One-touch fitting (●) Pipe thread type: NPT).
- *4 When pressure is not applied, condensate which does not start the auto drain mechanism will be left in the bowl. Releasing the residual condensate before ending operations for the day is recommended.
- *5 If the compressor is small (0.75 kW, discharge flow is less than 100 L/min (ANR)), air leakage from the drain cock may occur during the start of operations. N.C. type is recommended.
- *6 When the pressure gauge is attached, a 1.0 MPa pressure gauge will be fitted for standard (0.85 MPa) type. 0.4 MPa pressure gauge for 0.2 MPa type.

- *7 When choosing with H (panel mount), the installation space for lead wires will not be secured. In this case, select "wiring bottom entry" for the electrical entry.
- *8 Pressure can be set higher than the specification pressure in some cases, but use pressure within the specification range.
- *9 Refer to chemical data on page 12 for chemical resistance of the bowl.
- *10 A bowl guard is provided as standard equipment (polycarbonate).
- *11 A bowl guard is provided as standard equipment (nylon).
- *12 The combination of float type auto drain C and D is not available.
- *13 Without a valve function. The mounting screws are the same as the thread of (●).

- *14 The combination of metal bowl 2 and 8 is not available.
- *15 For the pipe thread type: NPT
This product is for overseas use only according to the New Measurement Act. (The SI unit type is provided for use in Japan.)
Cannot be used with M: Round type pressure gauge (with color zone). Available by request for special. The digital pressure switch will be equipped with the unit selection function, setting to psi initially.
- *16 For options: E1, E2, E3, E4
- *17 ○: For the pipe thread type: NPT only
- *18 △: Select with options: E1, E2, E3, E4.

AWM20-D to AWM40-D Series

AWD20-D to AWD40-D Series

Standard Specifications

Model		AWM20-D/AWD20-D	AWM30-D/AWD30-D	AWM40-D/AWD40-D
Port size		1/8, 1/4	1/4, 3/8	1/4, 3/8, 1/2
Pressure gauge port size*1		1/8		
Fluid		Air		
Ambient and fluid temperatures*2		-5 to 60°C (No freezing)		
Proof pressure		1.5 MPa		
Max. operating pressure		1.0 MPa		
Set pressure range	Without auto drain	0.05 to 0.85 MPa		
	Auto drain (N.C.)	0.1 to 0.85 MPa	0.15 to 0.85 MPa	
	Auto drain (N.O.)	—	0.1 to 0.85 MPa	
Max. flow capacity*3	[AWM]	150 L/min (ANR)	330 L/min (ANR)	820 L/min (ANR)
	[AWD]	90 L/min (ANR)	180 L/min (ANR)	450 L/min (ANR)
Nominal filtration rating*4	[AWM]	0.3 µm (99.9% filtered particle size)		
	[AWD]	0.01 µm (99.9% filtered particle size)		
Outlet side oil mist concentration*5, *6	[AWM]	Max. 1.0 mg/m ³ (≈ 0.8 ppm)		
	[AWD]	Max. 0.1 mg/m ³ (Before saturated with oil 0.01 mg/m ³ or less ≈ 0.008 ppm)		
Compressed air purity class*7, *8	[AWM]	ISO 8573-1:2010 [3 : 4 : 3]		
	[AWD]	ISO 8573-1:2010 [1 : 4 : 2]		
Drain capacity		8 cm ³	25 cm ³	45 cm ³
Bowl material		Polycarbonate		
Bowl guard		Semi-standard (Steel)	Standard (Polycarbonate)	
Construction		Relieving type		
Weight		0.23 kg	0.35 kg	0.66 kg

*1 Pressure gauge connection threads are not available for F.R.L. unit with a square embedded type pressure gauge or with a digital pressure switch.

*2 -5 to 50°C for the products with the digital pressure switch

*3 Inlet pressure: 0.7 MPa, Outlet pressure: 0.5 MPa. Flow at 20°C, atmospheric pressure, and 65% of the relative humidity

The max. flow capacity varies depending on the outlet pressure. Keep the air flow within the max. flow capacity to prevent an outflow of lubricant to the outlet side.

*4 For the following conditions in accordance with [Test condition: ISO 8573-4:2001, Test method ISO 12500-3:2009 compliant] in addition to the conditions above

Conditions: When a new element is used, and the flow capacity, inlet pressure, and the amount of solid bodies on the filter inlet side are stable

*5 The outlet side oil mist concentration for the following conditions in accordance with [Test condition: ISO 8573-2:2007, Test method ISO 12500-1:2007 compliant] in addition to the conditions above

Conditions: When a new element is used, the oil mist concentration on the filter inlet side is 10 mg/m³, and the flow capacity, inlet pressure, and the oil mist concentration on the filter inlet side are stable

*6 The bowl O-ring and other O-rings are slightly lubricated.

*7 The compressed air purity class is indicated based on ISO 8573-1:2010 Compressed air - Part 1: Contaminants and purity classes. For details on this standard, refer to page 14.

*8 The compressed air quality class on the inlet side is [7 : 4 : 4].

Bowl Assembly/Part Nos.

Bowl material	Drain discharge mechanism	Drain port	Other	Model			
				AWM20-D/AWD20-D	AWM30-D/AWD30-D	AWM40-D/AWD40-D	
Polycarbonate	Manual	With drain cock	—	C2SF-D	—	—	
			With bowl guard	C2SF-C-D	C3SF-D	C4SF-D	
		Drain cock with barb fitting	With bowl guard	—	C3SF-W-D	C4SF-W-D	
			—	C2SF□-J-D	—	—	
	Automatic*1 (Auto drain)	Normally closed (N.C.)	—	AD27-D	—	—	
			With bowl guard	AD27-C-D	AD37□-D	AD47□-D	
		Normally open (N.O.)	With bowl guard	—	AD38□-D	AD48□-D	
			—	C2SF-6-A	—	—	
Nylon	Manual	With drain cock	—	C2SF-6C-A	C3SF-6-A	C4SF-6-A	
			With bowl guard	—	C3SF-6W-A	C4SF-6W-A	
		Drain cock with barb fitting	With bowl guard	—	C3SF-6J-A	—	—
			—	C2SF□-6J-A	—	—	
	Automatic*1 (Auto drain)	Normally closed (N.C.)	—	AD27-6-A	—	—	
			With bowl guard	AD27-6C-A	AD37□-6-A	AD47□-6-A	
		Normally open (N.O.)	With bowl guard	—	AD38□-6-A	AD48□-6-A	
			—	C2SF-2-A	C3SF-2-A	C4SF-2-A	
Metal	Manual	With drain cock	—	C2SF-2J-A	C3SF-2J-A	C4SF-2J-A	
			With level gauge	—	C3LF-8-A	C4LF-8-A	
		With drain guide (without valve function)	—	C2SF□-2J-A	C3SF□-2J-A	C4SF□-2J-A	
			With level gauge	—	C3LF□-8J-A	C4LF□-8J-A	
	Automatic*1 (Auto drain)	Normally closed (N.C.)	—	AD27-2-A	AD37□-2-A	AD47□-2-A	
			With level gauge	—	AD37□-8-A	AD47□-8-A	
		Normally open (N.O.)	—	AD38□-2-A	AD48□-2-A		
			With level gauge	—	AD38□-8-A	AD48□-8-A	

*1 The bowl assembly comes with a bowl seal. □ in bowl assembly part numbers indicates a pipe thread type (applicable tubing for auto drain). No indication is necessary for RC thread; however, indicate N for NPT thread, and F for G thread. (For auto drain, Nil: ø10, N: ø3/8") Please contact SMC separately for psi and °F unit display specifications.

Mist Separator Regulator **AWM20-D to AWM40-D Series**

Micro Mist Separator Regulator **AWD20-D to AWD40-D Series**

Option/Part Nos.

Optional specifications			Model		
			AWM20-D/AWD20-D	AWM30-D/AWD30-D	AWM40-D/AWD40-D
Bracket assembly*1			AW23P-270AS	AR33P-270AS	AR43P-270AS
Set nut			AR23P-260S	AR33P-260S	AR43P-260S
Pressure gauge*2	Round type	Standard	G36-10-□01		G46-10-□01
		0.05 to 0.2 MPa setting	G36-4-□01		G46-4-□01
	Round type (with color zone)	Standard	G36-10-□01-L		G46-10-□01-L
		0.05 to 0.2 MPa setting	G36-4-□01-L		G46-4-□01-L
	Square embedded type*3	Standard	GC3-10AS-D [136150A (Pressure gauge cover only)]		
		0.05 to 0.2 MPa setting	GC3-4AS-D [136150A (Pressure gauge cover only)]		
Digital pressure switch			NPN output, Wiring bottom entry	ISE35-N-25-MLA-X523 [ISE35-N-25-M (Switch body only)]*4	
			NPN output, Wiring top entry	ISE35-R-25-MLA-X523 [ISE35-R-25-M (Switch body only)]*4	
			PNP output, Wiring bottom entry	ISE35-N-65-MLA-X523 [ISE35-N-65-M (Switch body only)]*4	
			PNP output, Wiring top entry	ISE35-R-65-MLA-X523 [ISE35-R-65-M (Switch body only)]*4	

*1 The assembly consists of a bracket and set nuts.

*2 □ in part numbers for a round type pressure gauge indicates a pipe thread type. No indication is necessary for R; however, indicate N for NPT. Please contact SMC regarding the pressure gauge supply for both MPa and psi unit specifications.

*3 Including one O-ring and 2 mounting screws. []: Pressure gauge cover only

*4 In addition to the pressure switch body, lead wire with connector (2 m), adapter, lock pin, O-ring (1 pc.), mounting screws (2 pcs.) are attached. []: Switch body only (Regarding how to order the digital pressure switch, refer to the **Web Catalog**.)

AWM20 to 40-D, AWD20 to 40-D

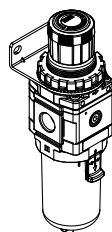
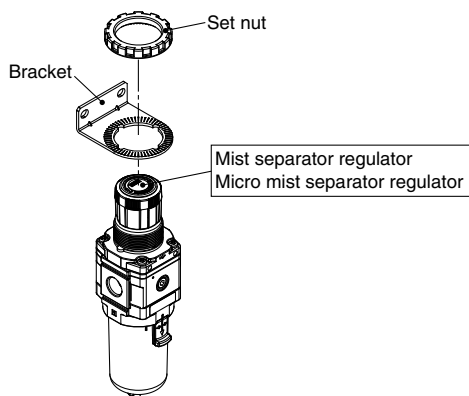

Bracket assembly

Replacement Parts

Description		Part no.		
		AWM20-D/AWD20-D	AWM30-D/AWD30-D	AWM40-D/AWD40-D
Valve assembly		AWM24P-090AS	AWM34P-090AS	AWM44P-090AS
Element assembly	AWM	AFM20P-060AS	AFM30P-060AS	AFM40P-060AS
	AWD	AFD20P-060AS	AFD30P-060AS	AFD40P-060AS
Diaphragm assembly	Relieving type	AR24P-150AS	AR34P-150AS	AR44P-150AS
	Non-relieving type	AR24P-150AS-N	AR34P-150AS-N	AR44P-150AS-N
Bowl seal		C2SFP-260S	C32FP-260S	C42FP-260S
Bowl assembly*1, *2		Refer to "Bowl Assembly/Part Nos."		

*1 The bowl assembly comes with a bowl seal.

*2 Please contact SMC separately for psi and °F unit display specifications.

AWM20-D to AWM40-D Series

AWD20-D to AWD40-D Series

Flow Rate Characteristics (Representative values)

Inlet pressure: 0.7 MPa

AWM20-D Rc1/4

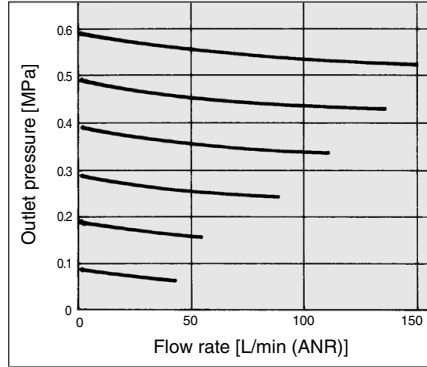

AWM30-D Rc3/8

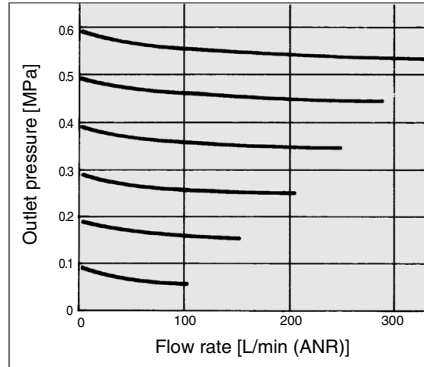

AWM40-D Rc1/2

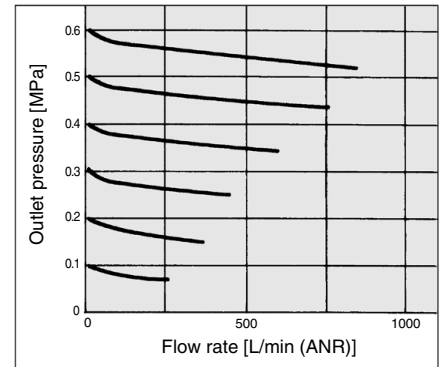

AWD20-D Rc1/4

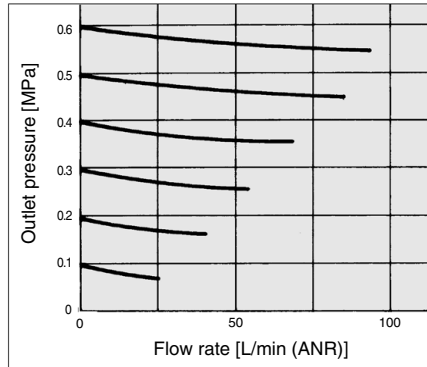

AWD30-D Rc3/8

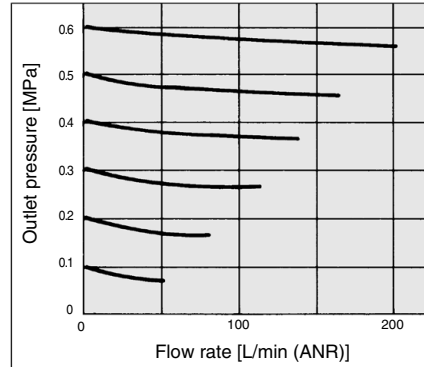

AWD40-D Rc1/2

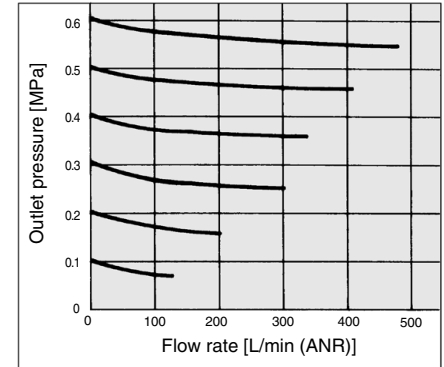

Pressure Characteristics (Representative values)

Conditions/Inlet pressure: 0.7 MPa, Outlet pressure: 0.2 MPa, Flow rate: 20 L/min (ANR)

AWM(D)20-D

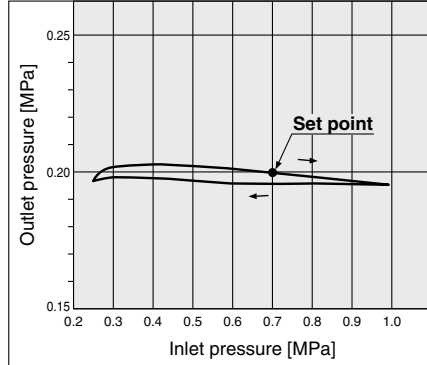

AWM(D)30-D

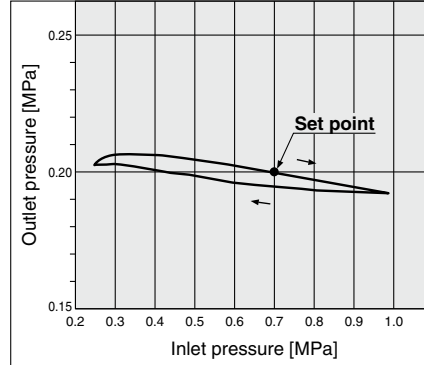

AWM(D)40-D

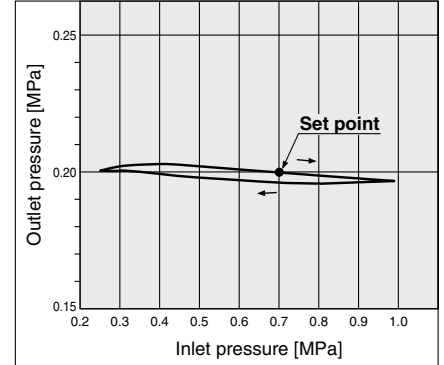

Mist Separator Regulator **AWM20-D to AWM40-D Series** Micro Mist Separator Regulator **AWD20-D to AWD40-D Series**

Dimensions

Standard (Round Type Pressure Gauge)
AWM20-D/AWD20-D

AWM30-D, AWM40-D/AWD30-D, AWD40-D

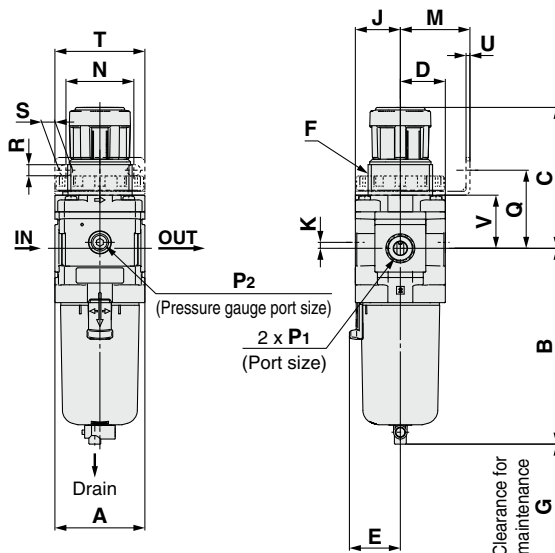
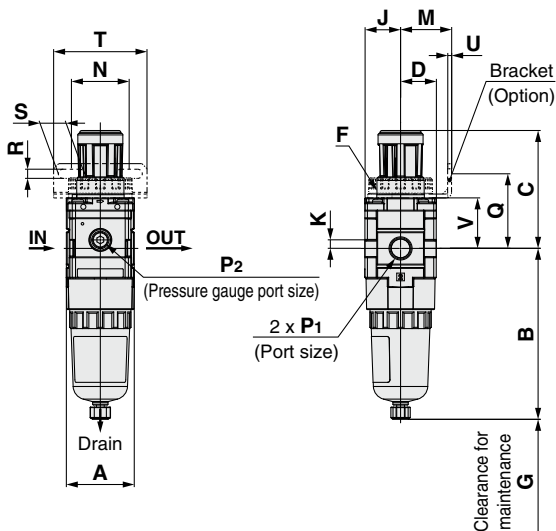

Panel cutout dimensions

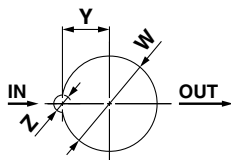
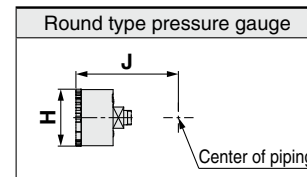

Plate thickness
AWM20-D, AWM30-D/AWD20-D, AWD30-D: Max. 3.5
AWM40-D/AWD40-D : Max. 5



Applicable model	Optional specifications	Semi-standard						
		With auto drain	PC/PA bowl		Metal bowl		Metal bowl with level gauge	
			Drain cock with barb fitting	With drain guide	With drain cock	With drain guide	With drain cock	With drain guide
AWM20-D AWD20-D								
AWM30-D AWD30-D AWM40-D AWD40-D	N.O.: Black N.C.: Gray Thread type/Rc, G: $\phi 10$ One-touch fitting Thread type/NPT: $\phi 3/8$ " One-touch fitting							

Model	Standard specifications												Optional specifications					
													Round type pressure gauge		Round type pressure gauge (Semi-standard: Z)		Round type pressure gauge (with color zone)	
	P ₁	P ₂	A	B	C*1	D	E	F	G	J	K	H	J	H	J	H	J	
AWM20-D/AWD20-D	1/8, 1/4	1/8	40	100.6	71.8	21	—	M28 x 1	45	21	5	$\phi 37.5$	57.5	$\phi 37.5$	58.5	$\phi 37.5$	58.5	
AWM30-D/AWD30-D	1/4, 3/8	1/8	53	115.4	86.5	26.5	30	M38 x 1.5	50	26.5	3.5	$\phi 37.5$	63	$\phi 37.5$	64	$\phi 37.5$	64	
AWM40-D/AWD40-D	1/4, 3/8, 1/2	1/8	70	147.1	91.5	35.5	38.4	M42 x 1.5	75	35.5	—	$\phi 42.5$	73	$\phi 42.5$	73	$\phi 42.5$	73	

Model	Optional specifications												Semi-standard specifications						
	Bracket mount						Panel mount						With auto drain	PC/PA bowl		Metal bowl		Metal bowl with level gauge	
														With barb fitting	With drain guide	With drain cock	With drain guide	With drain cock	With drain guide
	M	N	Q	R	S	T	U	V	W	Y	Z	B		B	B	B	B	B	
AWM20-D/AWD20-D	30	34	43.9	5.4	15.4	55	2.3	29.7	28.5	14	6	117.9	—	104.4	100.4	106.9	—	—	
AWM30-D/AWD30-D	41	40	46	6.5	8	53	2.3	31.3	38.5	19	7	157.1	123.9	122.2	117.8	122.3	137.8	142.3	
AWM40-D/AWD40-D	50	54	54	8.5	10.5	70	2.3	35.5	42.5	21	7	186.9	155.6	153.9	149.6	154.1	169.6	174.1	

*1 The dimension of C is the length when the knob is unlocked.

AWM20-D to AWM40-D Series AWD20-D to AWD40-D Series

Dimensions

Standard (Square Embedded Type Pressure Gauge, Digital Pressure Switch)

AWM20
AWD20

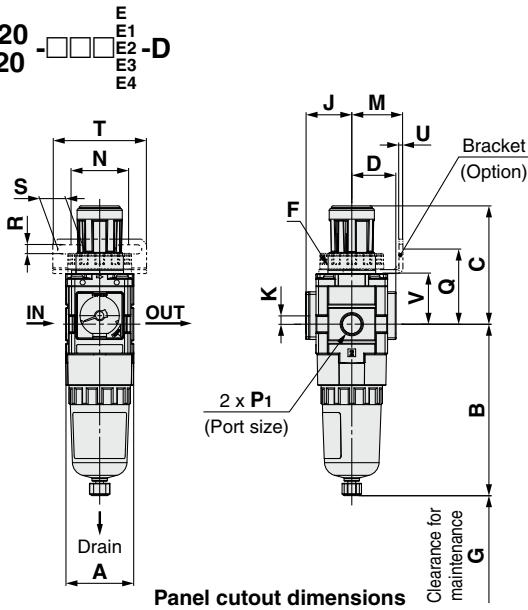

Panel cutout dimensions

Plate thickness

AWM20-D, AWM30-D/AWD20-D, AWD30-D: Max. 3.5
AWM40-D/AWD40-D : Max. 5

AWM30
AWD30

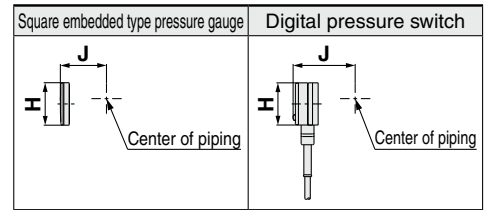
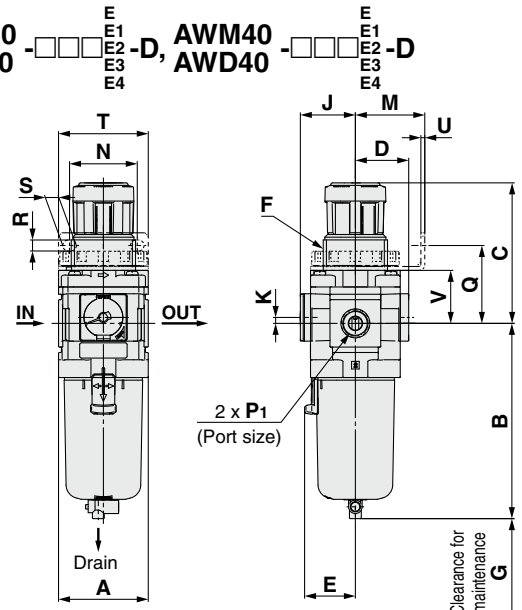

Applicable model	Optional specifications With auto drain	Semi-standard					
		PC/PA bowl		Metal bowl		Metal bowl with level gauge	
		Drain cock with barb fitting	With drain guide	With drain cock	With drain guide	With drain cock	With drain guide
AWM20-D AWD20-D	 M5 x 0.8		 1/8 Width across flats 14	 1/8 Width across flats 14			
AWM30-D AWD30-D AWM40-D AWD40-D	N.O.: Black N.C.: Gray Thread type/Rc, G: ø10 One-touch fitting Thread type/NPT: ø3/8 One-touch fitting	 Barb fitting applicable tubing: T0604	 1/4 Width across flats 17	 1/4 Width across flats 17	 1/4 Width across flats 17	 1/4 Width across flats 17	 1/4 Width across flats 17

Model	Standard specifications											Optional specifications	
	P ₁	A	B	C*1	D	E	F	G	K	H	J	H	J
AWM20-D/AWD20-D	1/8, 1/4	40	100.6	71.8	26	—	M28 x 1	45	5	□28	27	□27.8	37.5
AWM30-D/AWD30-D	1/4, 3/8	53	115.4	86.5	31.5	30	M38 x 1.5	50	3.5	□28	32.5	□27.8	43
AWM40-D/AWD40-D	1/4, 3/8, 1/2	70	147.1	91.5	40.5	38.4	M42 x 1.5	75	—	□28	41.5	□27.8	52

Model	Optional specifications											Semi-standard specifications						
	Bracket mount						Panel mount					With auto drain B	PC/PA bowl		Metal bowl		Metal bowl with level gauge	
	M	N	Q	R	S	T	U	V	W	Y	Z		With barb fitting B	With drain guide B	With drain cock B	With drain guide B	With drain cock B	With drain guide B
AWM20-D/AWD20-D	30	34	43.9	5.4	15.4	55	2.3	29.7	28.5	14	6	117.9	—	104.4	100.4	106.9	—	—
AWM30-D/AWD30-D	41	40	46	6.5	8	53	2.3	31.3	38.5	19	7	157.1	123.9	122.2	117.8	122.3	137.8	142.3
AWM40-D/AWD40-D	50	54	54	8.5	10.5	70	2.3	35.5	42.5	21	7	186.9	155.6	153.9	149.6	154.1	169.6	174.1

*1 The dimension of C is the length when the knob is unlocked.

AWM-D/AWD-D Series Spacer / Spacer with Bracket

Spacer / Spacer with Bracket

Y 300 - D

① ②

Spacer
(Y□-D)

Spacer with bracket
(Y□T-D)



	Symbol	Description	①		
			Body size [Applicable model]		
			200 [AWM20-D/AWD20-D]	300 [AWM30-D/AWD30-D]	400 [AWM40-D/AWD40-D]
②	Spacer	Nil	●	●	●
		T	●	●	●

Standard Specifications

Fluid	Air
Ambient and fluid temperatures	-5 to 60°C (No freezing)
Proof pressure	1.5 MPa
Max. operating pressure	1.0 MPa

Replacement Parts

Description	Material	Part no.		
		Y200-D Y200T-D	Y300-D Y300T-D	Y400-D Y400T-D
Seal	HNBR	Y220P-050S	Y320P-050S	Y420P-050S

Dimensions

Spacer

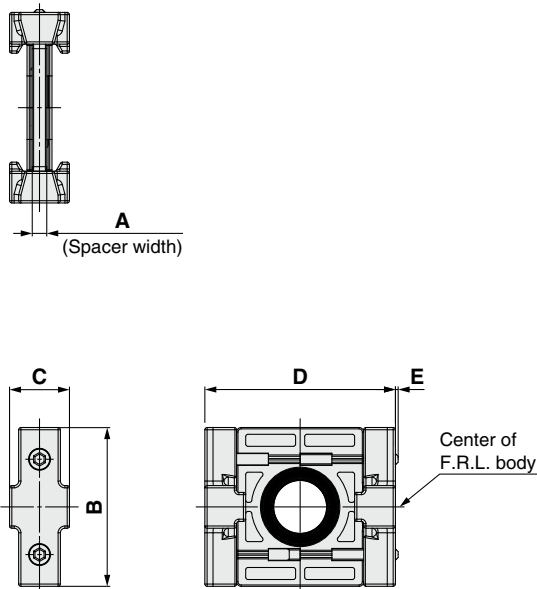

Spacer with bracket

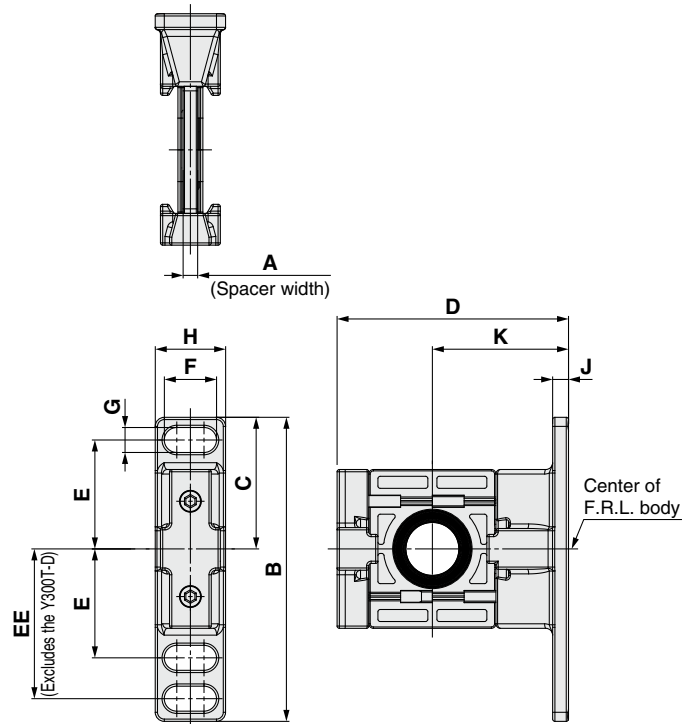

Model	A	B	C	D	E	Applicable model
Y200-D	3.2	35	13.2	42	0.6	AWM20-D AWD20-D
Y300-D	4.2	43	16.2	53	—	AWM30-D AWD30-D
Y400-D	5.2	51	19.2	71	—	AWM40-D AWD40-D

Model	A	B	C	D	E	EE	F	G	H	J	K	Applicable model
Y200T-D	3.2	67	29	51	24	33	11.5	5.5	15.5	3.5	30	AWM20-D AWD20-D
Y300T-D	4.2	85	42.5	67.5	35	—	14	7	20	6	41	AWM30-D AWD30-D
Y400T-D	5.2	115	50	85.5	40	55	18	9	26	7	50	AWM40-D AWD40-D

AWM-D/AWD-D Series Option

Knob Cover

Can be mounted on the knob in order to prevent the accidental operation of the knob

AR 34 P - 580AS

● Size

24
34
44

Standard Specifications

Ambient temperature	-5 to 60°C
---------------------	------------

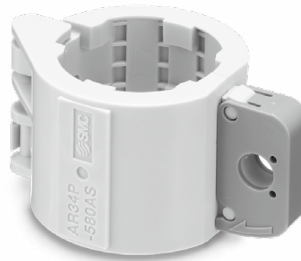

Dimensions

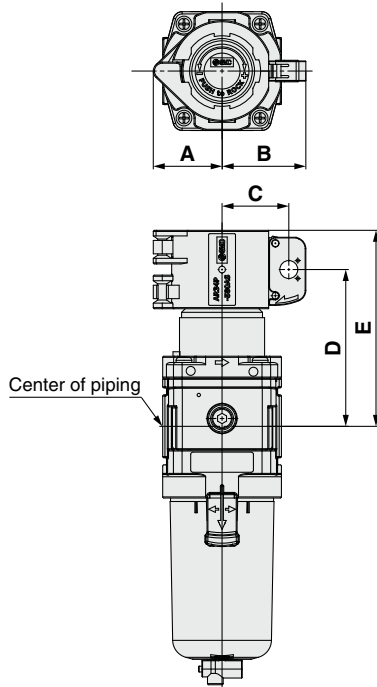

Detailed dimensions of the lock hole

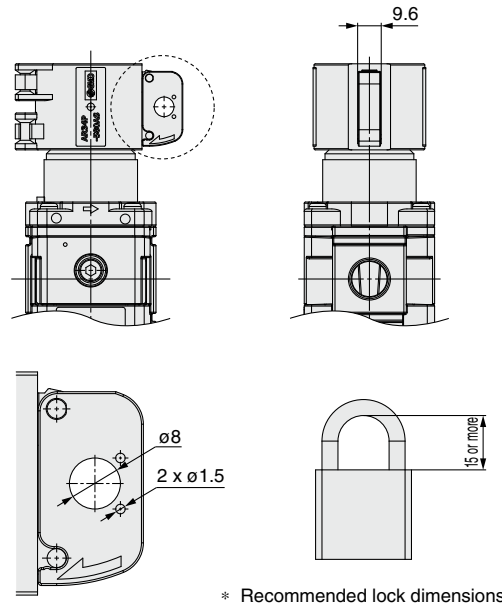

Part no.	A	B	C	D	E	Applicable model
AR24P-580AS	23.5	32.1	24.5	58.1	74.1	AWM/AWD20-D
AR34P-580AS	30.7	37.4	29.8	70	87.5	AWM/AWD30-D
AR44P-580AS	32.8	39.4	31.8	74.5	97	AWM/AWD40-D

Mounting Precautions

Before mounting the knob cover, confirm that the knob is in the locked state (in which the orange line is not visible).

Mount the cover in accordance with the mounting instructions below.

1 Mount the knob cover on the knob.

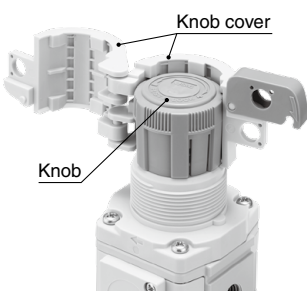

2 Close the lock cover.

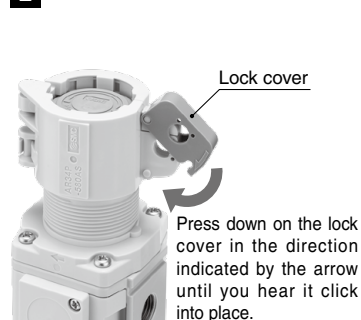

3 Secure with a lock (provided by the customer).



The knob cover can be mounted at each mounting angle in relation to the knob.

<Mounting angle>
Size 20: 30° (12 directions)
Sizes 30, 40: 60° (6 directions)

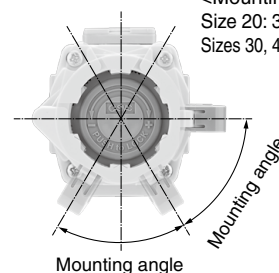



AWM-D/AWD-D Series Specific Product Precautions 1

Be sure to read this before handling the products. Refer to the back cover for safety instructions. For F.R.L. units precautions, refer to the “Handling Precautions for SMC Products” and the “Operation Manual” on the SMC website.

Design / Selection

Warning

- Residual pressure disposal (outlet pressure removal) is not possible for the AWM20-D to AWM40-D and AWD20-D to AWD40-D even though the inlet pressure is exhausted. To remove residual pressure, use the combination of a filter regulator with backflow function (AW20K-D to AW40K-D) and mist separator (AFM20-D to AFM40-D), or the combination of a filter regulator with backflow function (AW20K-D to AW40K-D), mist separator (AFM20-D to AFM40-D), and micro mist separator (AFD20-D to AFD40-D).
- The standard bowl for the mist separator regulator and micro mist separator regulator is made of polycarbonate. Do not use in an environment where they are exposed to or come in contact with organic solvents, chemicals, cutting oil, synthetic oil, alkali, or thread lock solutions.

Chemical Resistance of Polycarbonate or Nylon Bowl

Type	Chemical name	Application examples	Material	
			Polycarbonate	Nylon
Acid	Hydrochloric acid Sulfuric acid Phosphoric acid Chromic acid	Acid washing liquid for metals	△	×
Alkaline	Sodium hydroxide (Caustic soda) Potash Calcium hydroxide (Slack lime) Ammonia water Sodium carbonate	Degreasing of metals Industrial salts Water-soluble cutting oil	×	○
Inorganic salts	Sodium sulfide Potassium nitrate Sodium sulfate	—	×	△
Chlorine solvents	Carbon tetrachloride Chloroform Ethylene chloride Methylene chloride	Cleansing liquid for metals Printing ink Dilution	×	△
Aromatic series	Benzene Toluene Paint thinner	Coatings Dry cleaning	×	△
Ketone	Acetone Methyl ethyl ketone Cyclohexane	Photographic film Dry cleaning Textile industries	×	×
Alcohol	Ethyl alcohol IPA Methyl alcohol	Antifreeze Adhesives	△	×
Oil	Gasoline Kerosene	—	×	○
Ester	Phthalic acid dimethyl Phthalic acid diethyl Acetic acid	Synthetic oil Anti-rust additives	×	○
Ether	Methyl ether Ethyl ether	Brake oil additives	×	○
Amino	Methyl amino	Cutting oil Brake oil additives Rubber accelerator	×	×
Others	Thread-lock fluid Seawater Leak tester	—	×	△

○: Essentially safe △: Some effects may occur. ×: Effects will occur.

When the above factors are present, or there is some doubt, use a metal bowl for safety.

Design / Selection

Caution

- Design the system so that the product is installed in a pulsation-free location. The difference between internal and external pressure inside the element should be kept within 0.1 MPa, as exceeding this value could cause damage.

Air Source

Caution

- When the element becomes clogged at an early stage, please check the air quality. In addition, early clogging can be prevented by attaching a pre-filter on the inlet side of the product.

Maintenance

Warning

- Replace the element every 2 years or when the pressure drop becomes 0.1 MPa, whichever comes first, to prevent damage to the element.

Mounting / Adjustment

Warning

- Set the product while verifying the displayed values of the inlet and outlet pressure gauges. Turning the regulator knob excessively can cause damage to the internal parts.
- Do not use tools on the pressure regulator knob as this may cause damage. It must be operated manually.

Caution

- Be sure to unlock the knob before adjusting the pressure and lock it after setting the pressure.

Failure to follow this procedure can cause damage to the knob and the outlet pressure may fluctuate.

- Pull the pressure regulator knob to unlock. (You can visually verify this with the “orange mark” that appears in the gap.)
- Push the pressure regulator knob to lock. When the knob is not easily locked, turn it left and right a little and then push it (when the knob is locked, the “orange mark”, i.e., the gap will disappear).

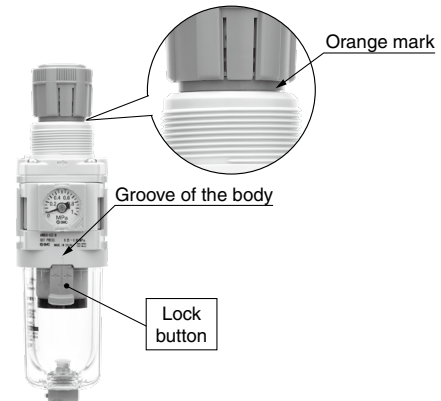

- When the bowl is installed on the AWM30-D to AWM40-D or AWD30-D to AWD40-D, install it so that the lock button lines up to the groove of the front (or the back) of the body to avoid drop or damage of the bowl.



AWM-D/AWD-D Series Specific Product Precautions 2

Be sure to read this before handling the products. Refer to the back cover for safety instructions. For F.R.L. units precautions, refer to the “Handling Precautions for SMC Products” and the “Operation Manual” on the SMC website.

Piping

Warning

1. Tighten the 2 holding screws on the spacer with bracket or spacer evenly.

Tighten them to the recommended tightening torque.
Insufficient tightening torque may result in loosening or sealing failure. Excessive tightening torque may damage the thread, etc.

Recommended Torque

Unit: N·m

Applicable model	AWM20-D AWD20-D	AWM30-D AWD30-D	AWM40-D AWD40-D
Spacer with bracket part no.	Y200T-D	Y300T-D	Y400T-D
Spacer part no.	Y200-D	Y300-D	Y400-D
Torque	0.36 ±0.036	1.2 ±0.05	1.2 ±0.05

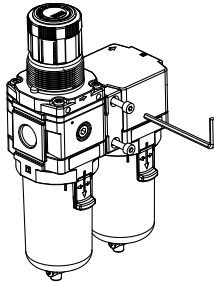

2 screws on the spacer with bracket or spacer

2. Place the spacer with bracket (or spacers) so that excessive moment is not applied to the spacer with bracket (or spacers) due to the weight of the product or the external force applied at the time of piping.

If the moment including the own weight of the external piping exceeds the max. moment shown in the table below, support the external piping separately.

Piping materials without flexibility, such as steel tube piping, are prone to being affected by excess moment loads or vibrations from the piping side. Use flexible tubing in between to avoid such effects.

Unit: N·m

Applicable model	AWM20-D AWD20-D	AWM30-D AWD30-D	AWM40-D AWD40-D
Max. moment (M)	14.5	16	19.5

$$\text{Max. moment (M)} = \text{Length (L)} \times \text{Load (F)}$$

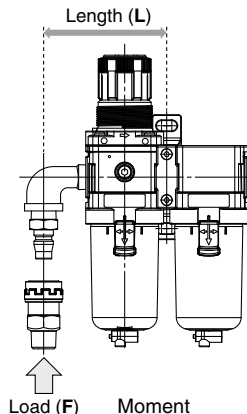

Piping

Warning

3. Connect piping/fittings using the recommended torque while holding the female thread side tightly.

Insufficient tightening torque can result in loose piping or sealing failure. Over tightening may break the thread. If the female side is not held while tightening, excessive force will be applied to the bracket directly, resulting in breakage.

Recommended Torque

Unit: N·m

Connection thread	1/8	1/4	3/8	1/2
Torque	7 to 9	12 to 14	22 to 24	28 to 30

4. To screw the pressure gauge and piping materials into the pressure gauge port on the product, tighten to the recommended torque (3 to 5 N·m) while securely holding the product in place.
5. When mounting a One-touch fitting, refer to the Fittings and Tubing Precautions.

Selection

Caution

1. Do not flow air exceeding the max. air flow rate.

If the max. air flow rate is momentarily exceeded, it may cause splashing of drainage and oil on the outlet side, and damage to the equipment.

International Standard ISO 8573-1:2010

Compressed Air Purity Classes

Compressed air is used in a variety of manufacturing processes. In this age, compressed air with a high degree of purity is becoming increasingly necessary.

For this reason, it is necessary to remove contaminants from systems which supply compressed air and to secure the quality. The standard which stipulates the class according to the quantities of contaminants in compressed air is ISO 8573-1.

[Outline]

Stipulates the purity class of contaminants (particles, water, oil) mixed in with the compressed air

[Scope]

Can be used in various places in compressed air systems

[Terms and Definitions]

- Purity class: An index assigned for each classification obtained by dividing the concentration of each contaminant into ranges
- Particle: Small discrete mass of solid or liquid matter
- Humidity and liquid water: Water vapor (gas), Water droplets
- Oil: Liquid oil, Oil mist, Vapor

[Purity Classes]

Class	Particles			Mass concentration Cp [mg/m ³]	Humidity and liquid water		Oil Concentration of total oil [mg/m ³]
	Max. number of particles per cubic meter as a function of particle size d [μm] 0.1 < d ≤ 0.5	0.5 < d ≤ 1.0	1.0 < d ≤ 5.0		Pressure dew point [°C]	Concentration of liquid water Cw [g/m ³]	
0	As specified by the equipment user or supplier and more stringent than class 1						
1	≤ 20000	≤ 400	≤ 10	—	≤ -70	—	≤ 0.01
2	≤ 400000	≤ 6000	≤ 100	—	≤ -40	—	≤ 0.1
3	—	≤ 90000	≤ 1000	—	≤ -20	—	≤ 1
4	—	—	≤ 10000	—	≤ +3	—	≤ 5
5	—	—	≤ 100000	—	≤ +7	—	—
6	—	—	—	0 < Cp ≤ 5	≤ +10	—	—
7	—	—	—	5 < Cp ≤ 10	—	Cw ≤ 0.5	—
8	—	—	—	—	—	0.5 < Cw ≤ 5	—
9	—	—	—	—	—	5 < Cw ≤ 10	—
x	—	—	—	Cp > 10	—	Cw > 10	> 5

[How to Perform a Test to Check the Performance]

ISO 12500, which sets out the test method to be used in order to check the filter performance for each of the three kinds of contaminants, is indicated below.

- Particle: ISO 12500-3:2009
- Liquid water: ISO 12500-4:2009
- Oil: ISO 12500-1:2007

* Measured using a dedicated evaluation system which has been certified according to ISO 12500-□ and also by a third party (Certified)

[Purity Class Designation Example]

ISO 8573-1:2010 [4 : 6 : 2]

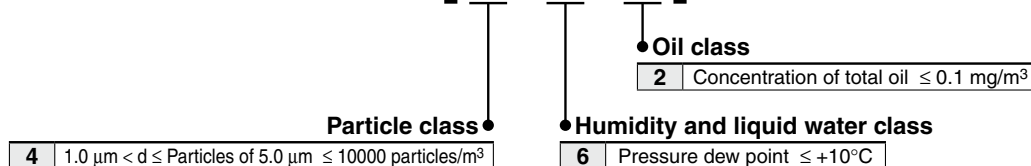

Air quality of the compressed air obtained for the system

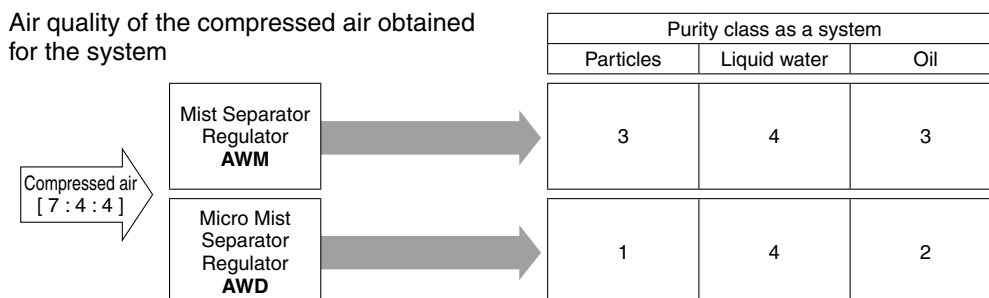



The class indicates the compressed air purity according to ISO 8573-1:2010 (JIS B 8392-1:2012) and indicates the max. purity class which can be obtained using that system. Note, however, that this value will differ according to the inlet air conditions.

Safety Instructions

These safety instructions are intended to prevent hazardous situations and/or equipment damage. These instructions indicate the level of potential hazard with the labels of “**Caution**,” “**Warning**” or “**Danger**.” They are all important notes for safety and must be followed in addition to International Standards (ISO/IEC)*1), and other safety regulations.

 **Caution:** **Caution** indicates a hazard with a low level of risk which, if not avoided, could result in minor or moderate injury.

 **Warning:** **Warning** indicates a hazard with a medium level of risk which, if not avoided, could result in death or serious injury.

 **Danger:** **Danger** indicates a hazard with a high level of risk which, if not avoided, will result in death or serious injury.

*1) ISO 4414: Pneumatic fluid power – General rules relating to systems.
ISO 4413: Hydraulic fluid power – General rules relating to systems.
IEC 60204-1: Safety of machinery – Electrical equipment of machines.
(Part 1: General requirements)
ISO 10218-1: Manipulating industrial robots – Safety.
etc.

Warning

1. The compatibility of the product is the responsibility of the person who designs the equipment or decides its specifications.

Since the product specified here is used under various operating conditions, its compatibility with specific equipment must be decided by the person who designs the equipment or decides its specifications based on necessary analysis and test results. The expected performance and safety assurance of the equipment will be the responsibility of the person who has determined its compatibility with the product. This person should also continuously review all specifications of the product referring to its latest catalog information, with a view to giving due consideration to any possibility of equipment failure when configuring the equipment.

2. Only personnel with appropriate training should operate machinery and equipment.

The product specified here may become unsafe if handled incorrectly. The assembly, operation and maintenance of machines or equipment including our products must be performed by an operator who is appropriately trained and experienced.

3. Do not service or attempt to remove product and machinery/equipment until safety is confirmed.

1. The inspection and maintenance of machinery/equipment should only be performed after measures to prevent falling or runaway of the driven objects have been confirmed.
2. When the product is to be removed, confirm that the safety measures as mentioned above are implemented and the power from any appropriate source is cut, and read and understand the specific product precautions of all relevant products carefully.
3. Before machinery/equipment is restarted, take measures to prevent unexpected operation and malfunction.

4. Contact SMC beforehand and take special consideration of safety measures if the product is to be used in any of the following conditions.

1. Conditions and environments outside of the given specifications, or use outdoors or in a place exposed to direct sunlight.
2. Installation on equipment in conjunction with atomic energy, railways, air navigation, space, shipping, vehicles, military, medical treatment, combustion and recreation, or equipment in contact with food and beverages, emergency stop circuits, clutch and brake circuits in press applications, safety equipment or other applications unsuitable for the standard specifications described in the product catalog.
3. An application which could have negative effects on people, property, or animals requiring special safety analysis.
4. Use in an interlock circuit, which requires the provision of double interlock for possible failure by using a mechanical protective function, and periodical checks to confirm proper operation.

Caution

1. The product is provided for use in manufacturing industries.

The product herein described is basically provided for peaceful use in manufacturing industries.
If considering using the product in other industries, consult SMC beforehand and exchange specifications or a contract if necessary.
If anything is unclear, contact your nearest sales branch.

Limited warranty and Disclaimer/ Compliance Requirements

The product used is subject to the following “Limited warranty and Disclaimer” and “Compliance Requirements”.

Read and accept them before using the product.

Limited warranty and Disclaimer

1. The warranty period of the product is 1 year in service or 1.5 years after the product is delivered, whichever is first.*2)
Also, the product may have specified durability, running distance or replacement parts. Please consult your nearest sales branch.
2. For any failure or damage reported within the warranty period which is clearly our responsibility, a replacement product or necessary parts will be provided.
This limited warranty applies only to our product independently, and not to any other damage incurred due to the failure of the product.
3. Prior to using SMC products, please read and understand the warranty terms and disclaimers noted in the specified catalog for the particular products.

*2) Vacuum pads are excluded from this 1 year warranty.

A vacuum pad is a consumable part, so it is warranted for a year after it is delivered.
Also, even within the warranty period, the wear of a product due to the use of the vacuum pad or failure due to the deterioration of rubber material are not covered by the limited warranty.

Compliance Requirements

1. The use of SMC products with production equipment for the manufacture of weapons of mass destruction (WMD) or any other weapon is strictly prohibited.
2. The exports of SMC products or technology from one country to another are governed by the relevant security laws and regulations of the countries involved in the transaction. Prior to the shipment of a SMC product to another country, assure that all local rules governing that export are known and followed.

Caution

SMC products are not intended for use as instruments for legal metrology.

Measurement instruments that SMC manufactures or sells have not been qualified by type approval tests relevant to the metrology (measurement) laws of each country. Therefore, SMC products cannot be used for business or certification ordained by the metrology (measurement) laws of each country.

Safety Instructions

Be sure to read the “Handling Precautions for SMC Products” (M-E03-3) and “Operation Manual” before use.