

Pulse Valve

Air

Valve for Dust Collector

RoHS

ATEX Compliant 55-JSXFA Series p. 15

Life: **10 million cycles*¹** or more/
10 times*² or more

High peak pressure and low air consumption

Peak pressure **15%*³** increase

Air consumption **35%*³** reduction

*1 Based on SMC's specific testing conditions (JSXFA-06, Pilot valve orifice of ø5 mm or larger)
*2 Compared with the existing SMC model

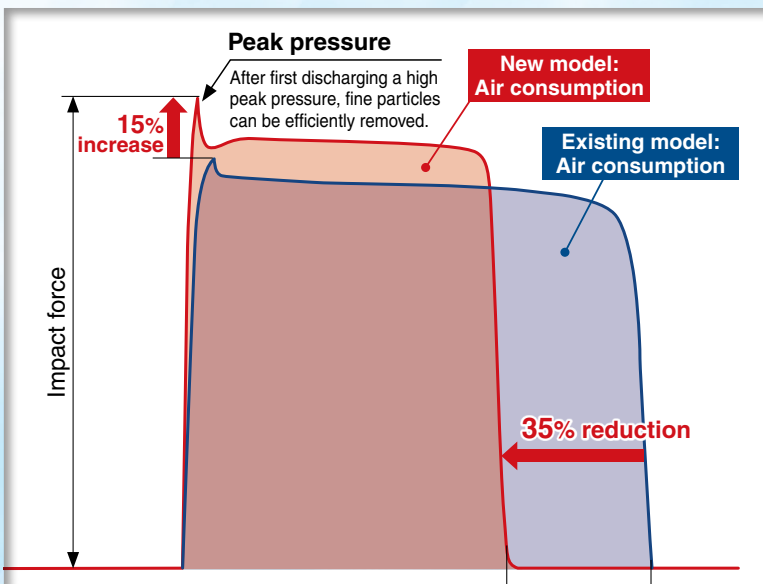

*3 When the pilot valve mounted on the JSXFA-06 is energized (ON time) for 100 ms

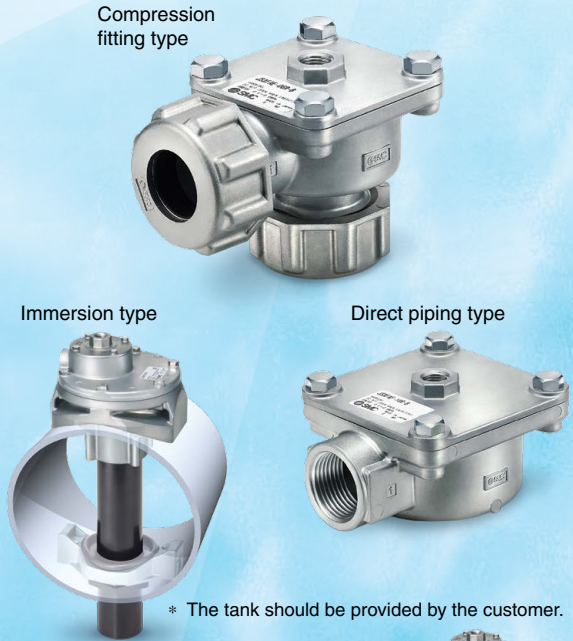

New
3/4 (20A), 1 1/2 (40A), and 2 (50A) port sizes have been added to the immersion type.

Fluid temperature: **-40 to 60°C**
Can be used in a wide range of temperatures

Variations

Piping	Port size	Orifice diameter mm	Thread type	Pilot port size	With/without silencer (Option)
Compression fitting type Direct piping type (Rc, NPT, G)	3/4 (20A)	ø32	Rc NPT G	1/8 1/4	Without
	1 (25A)	ø40			Without
	1 1/2 (40A)	ø50			With
Immersion type	New 3/4 (20A)	ø32			Without
	1 (25A)	ø40			Without
	New 1 1/2 (40A)	ø45			With
	New 2 (50A)	ø55	With		

JSXFA Series

Long service life: **10 million cycles**^{*1} or more

A spring is not necessary due to the high-strength elastomer diaphragm.

OFF response time: **45%**^{*1, 2} reduction

Easier maintenance

The springless diaphragm allows for easy maintenance of the valve. A main valve and sub-valve (for 40A) are included in the maintenance kit.

Flow rate characteristics:

40%^{*1, 2} increase

Optimal design for the internal geometry

No need to weld the tank piping

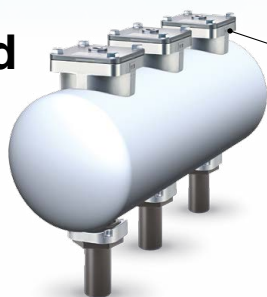

Immersion type

* The tank should be provided by the customer.

*1 Based on SMC's specific testing conditions (JSXFA-06, Pilot valve orifice of ø5 mm or larger, Excludes made-to-order option "A")
*2 Compared with the existing SMC model

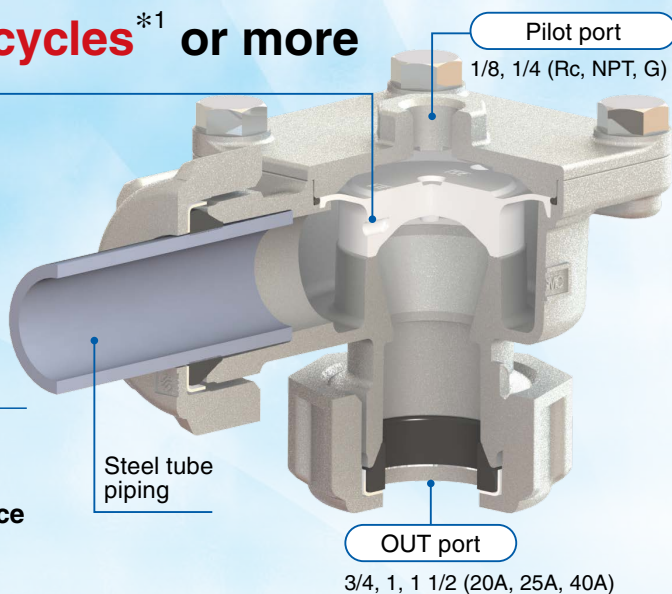

Compression fitting type
JSXFAE Series



3/4 (20A), 1 (25A), 1 1/2 (40A)

Direct piping type
JSXFAP Series



3/4 (20A), 1 (25A), 1 1/2 (40A)

Immersion type
JSXFAH Series

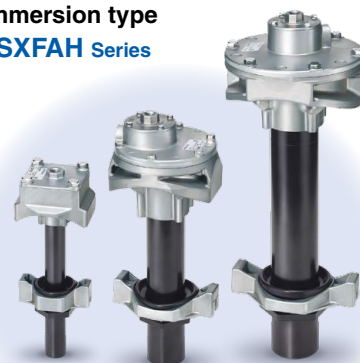

3/4 (20A), 1 (25A), 1 1/2 (40A), 2 (50A)

Dedicated Controller for Operation *VXFC Series* **p. 16**

The valve controller can turn the many valves for the dust controller ON/OFF.

Power supply voltage	85 to 240 VAC 12 VDC, 24 to 48 VDC	Number of output points	6 output points, 10 output points
----------------------	---------------------------------------	-------------------------	--------------------------------------

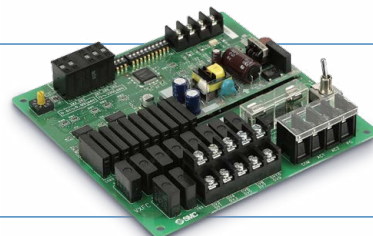

Pulse valve application examples

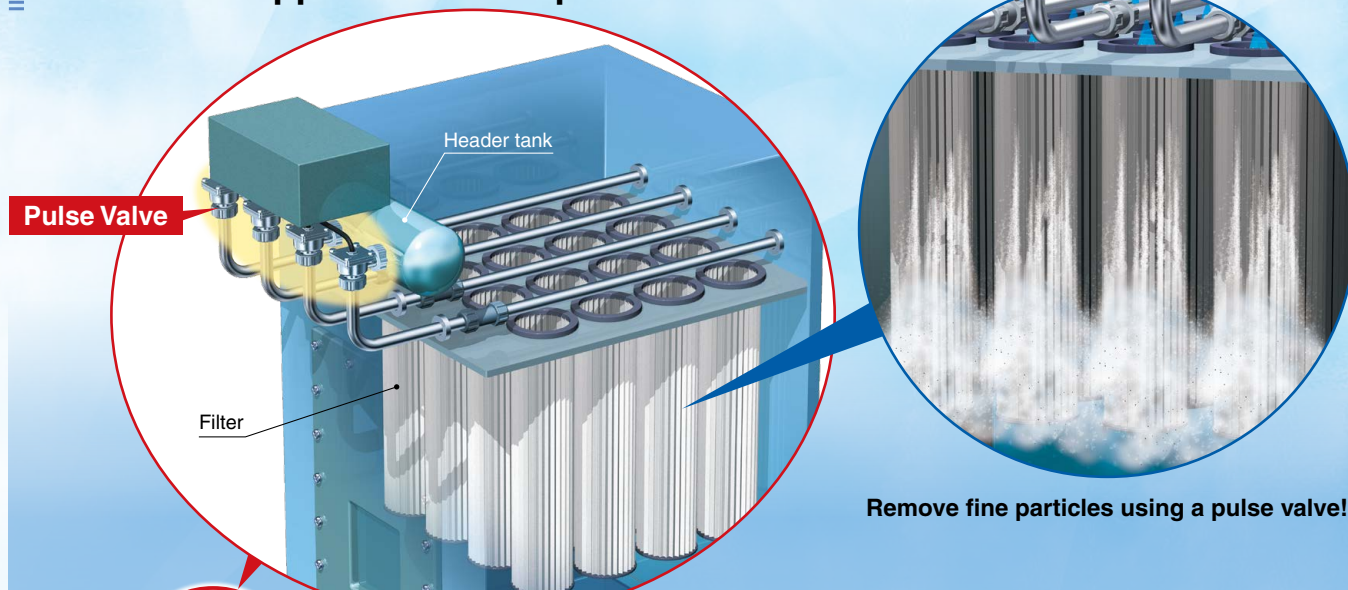

For mixing



For cutting

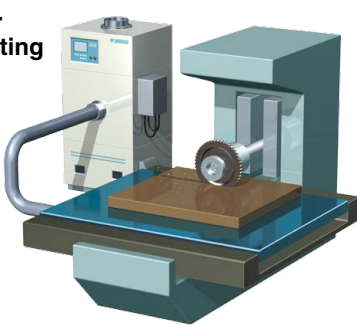

For pressing
(Blanking / Piercing)



Pulse blow can be used in various industries!

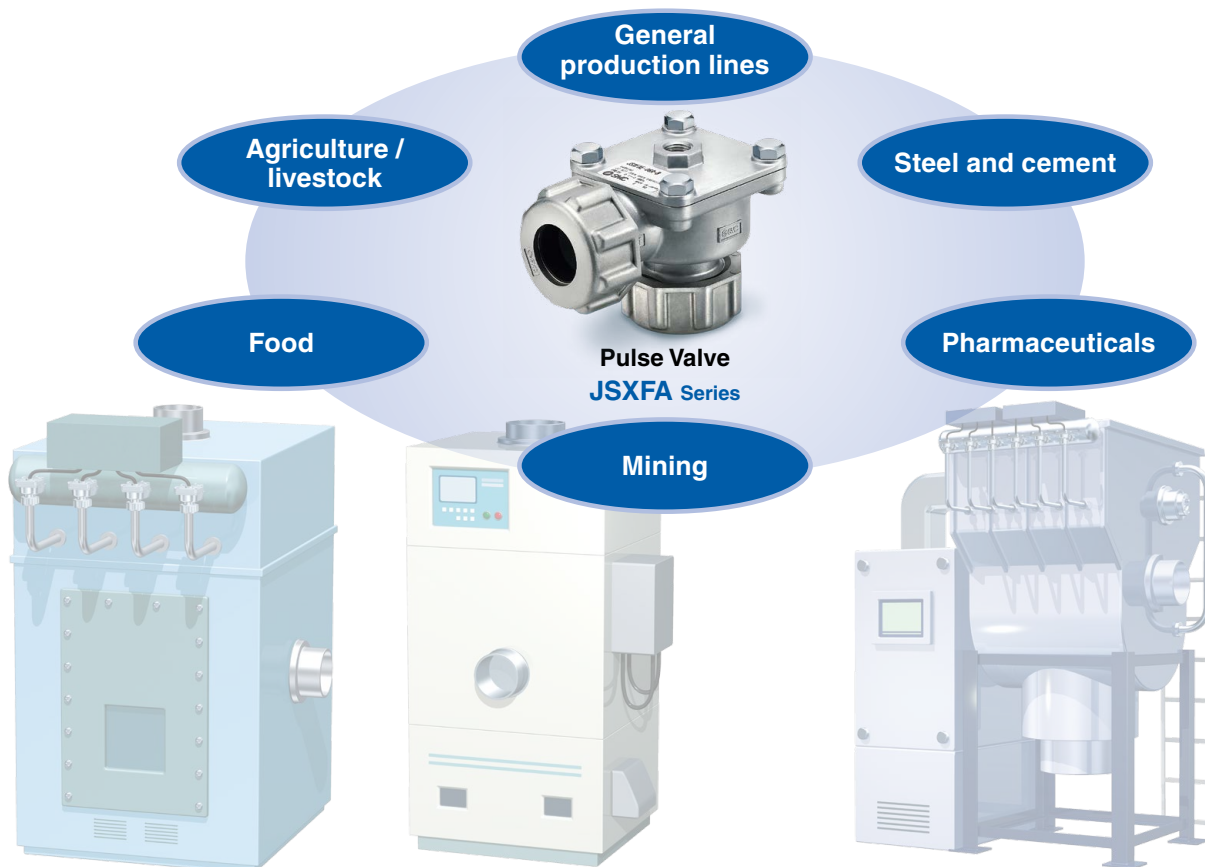

Pulse Valve Valve for Dust Collector

JSXFA Series



How to Order Air Operated

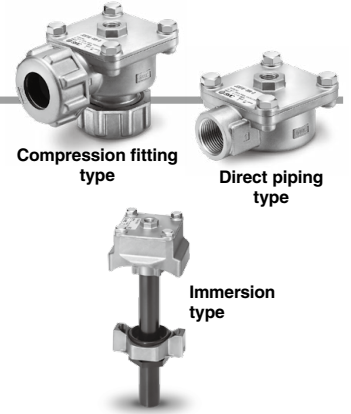

Compression	JSXFAE	-06R	-B-	1
Direct piping	JSXFAF	-06R	-B-	1
Immersion	JSXFAH	4-06R1	-B-	1
	1 2 3	4 5 6	7 8 9	

1 Valve type

A	Air Operated	
---	--------------	--

3 Tank size (JSXFAH only)

4	4 inch
5	5 inch
6	6 inch
8	8 inch
10	10 inch

4 Port size*1

06	3/4 (20A)
10	1 (25A)
14	1 1/2 (40A)
20*2	2 (50A)

*1 For port size selection, refer to the "Variations for port size and option" table below.
*2 Port size 20 is only available for the JSXFAH.

2 Piping

E	Compression fitting type*1	
F	Direct piping type	
H	Immersion type*2	

5 Thread type

R	Rc
N	NPT
F	G

6 OUT port piping configuration (JSXFAH only)

Symbol	Length	G thread	Appearance
1	Short	None	
2	Long		
3	Short	Yes	
4	Long		

7 Fluid and ambient temperatures

B	-40 to 60°C
---	-------------

8 Silencer (Only port size 14 and 20 can be selected.)

Nil	Without
S	With

9 Pilot port size

Nil	1/4
1	1/8

Shipped together with the product

*1 Seals and washers are included.

*2 The valve and pipe are not assembled in the package.

Caution

Pilot Valve Selection (JSXFA series common)

For the pilot valve orifice diameter, $\phi 5$ mm or larger is recommended. When the pilot orifice diameter is $\phi 3$ mm or larger and less than $\phi 5$ mm, put "A" to the end of the product number for made-to-order. The product may not operate correctly if the pilot valve orifice diameter is inadequate. (Port size: 3/4, 1) Depending on the pilot piping port size*1 or length, the valve may not operate correctly.

*1 The I.D. of the pilot piping must be larger than the pilot valve orifice diameter to use. The max. pilot piping I.D. is 10 mm.

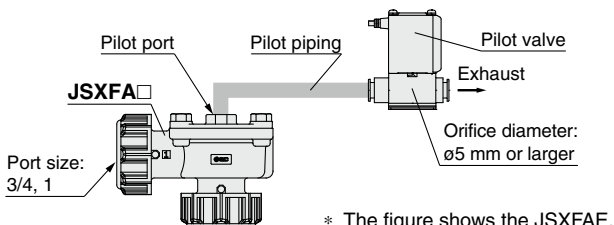

* The figure shows the JSXFAE.

Made to Order (JSXFA series common)

Pilot valve orifice diameter: Special specification

A	For $\phi 3$ mm to $\phi 5$ mm	Port size: 06, 10
---	--------------------------------	-------------------

JSXFA - - B - A

Enter the standard product number.

Variations for port size and option

Model	Tank size	Port size			
		06	10	14	20
JSXFAE	—	●	●	●	—
JSXFAP	—	●	●	●	—
JSXFAH	4 inch	●	—	—	—
	5 inch	●	●	—	—
	6 inch	—	●	●	—
	8 inch	—	—	●	●
	10 inch	—	—	—	●
Pilot valve orifice		●	●	—	—
Silencer		—	—	●	●

Specifications

Common Specifications



JSXFAE Series

Valve specifications	Fluid	Air
	Min. operating pressure differential [MPa]	0.1
	Max. operating pressure differential [MPa]	0.9
	Max. system pressure [MPa]	0.9
	Fluid temperature [°C]	-40*1 to 60
	Ambient temperature [°C]	-40 to 60
Operating environment	Indoor/Outdoor*2	

*1 No condensation

*2 For outdoor use, be sure to implement sufficient measures to protect the operational pilot valve from rain water.

Refer to the "2-Port Solenoid Valves for Fluid Control Precautions" for protective measures.

Be sure to read the "Specific Product Precautions" before handling.



JSXFAF Series

Individual Specifications Compression Fitting Type/Direct Piping Type

Series	JSXFAE/F			
	06	10	14	
Orifice diameter [mm]	ø32	ø40	ø50	
Port size	3/4	1	1 1/2	
Weight [g]	Compression	470	910	1,850
	Direct piping	290	500	1,230



JSXFAH Series

Individual Specifications Immersion Type

Series	JSXFAH									
	06		10		14		20			
Orifice diameter [mm]	ø32		ø40		ø45		ø55			
Port size	3/4		1		1 1/2		2			
Tank size [ANSI]	4	5	5	6	6	8	8	10		
Weight*3 [g]	Piping configuration	1	1,110	1,120	1,730	1,790	2,710	2,830	4,420	4,590
		2	1,140	1,160	1,780	1,890	2,870	3,060	4,740	4,900
		3	1,110	1,120	1,730	1,790	2,710	2,830	4,420	4,590
		4	1,140	1,160	1,780	1,890	2,870	3,060	4,740	4,900

*3 The tank weight is not included in the weight above.

JSXFA Series

Construction

JSXFAE/Compression Fitting Type

Port size: Sizes 06, 10

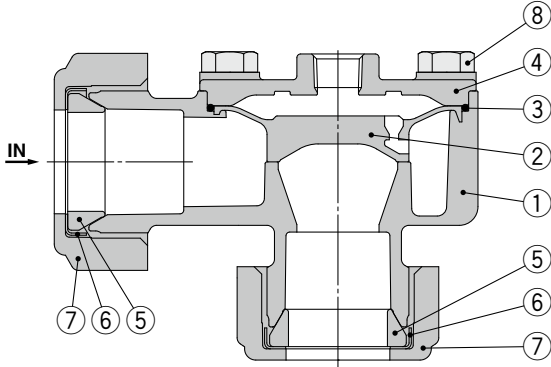

Component Parts

No.	Description	Material
1	Body	ADC
2	Main valve	Resin
3	O-ring	NBR
4	Bonnet	ADC
5	Seal	NBR
6	Washer	Fe (Chromated)
7	Compression nut	ADC
8	Hexagon bolt	Stainless steel

Port size: Size 14

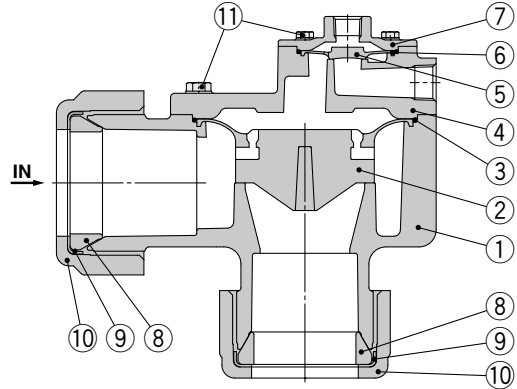

Component Parts

No.	Description	Material	No.	Description	Material
1	Body	ADC	8	Seal	NBR
2	Main valve	Resin	9	Washer	Fe (Chromated)
3	O-ring	NBR	10	Compression nut	ADC
4	Bonnet	ADC	11	Hexagon bolt	Stainless steel
5	Sub-valve	Resin			
6	O-ring	NBR			
7	Bonnet	ADC			

JSXFAD/Direct Piping Type

Port size: Sizes 06, 10

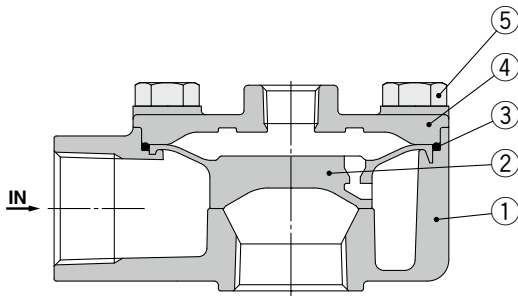

Component Parts

No.	Description	Material
1	Body	ADC
2	Main valve	Resin
3	O-ring	NBR
4	Bonnet	ADC
5	Hexagon bolt	Stainless steel

Port size: Size 14

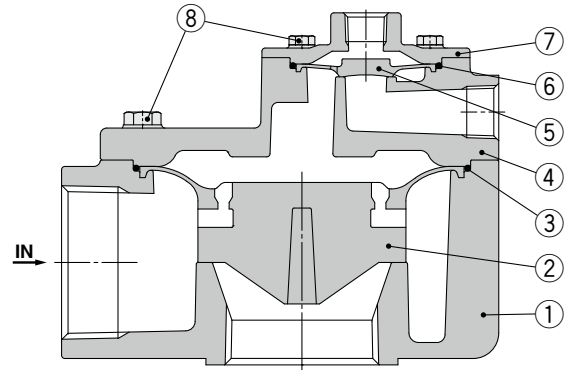

Component Parts

No.	Description	Material
1	Body	ADC
2	Main valve	Resin
3	O-ring	NBR
4	Bonnet	ADC
5	Sub-valve	Resin
6	O-ring	NBR
7	Bonnet	ADC
8	Hexagon bolt	Stainless steel

Construction

JSXFAH/Immersion type

Port size: Sizes 06, 10

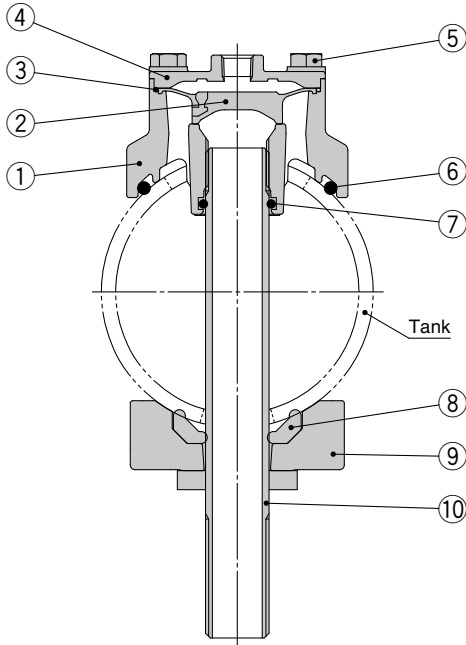

* The tank should be provided by the customer.

Component Parts

No.	Description	Material
1	Body	ADC
2	Main valve	Resin
3	O-ring	NBR
4	Bonnet	ADC
5	Hexagon bolt	Stainless steel
6	O-ring	NBR
7	O-ring	NBR
8	Gasket	NBR
9	Bottom support	ADC
10	Outlet pipe assembly	STKM + SS400

Port size: Sizes 14, 20

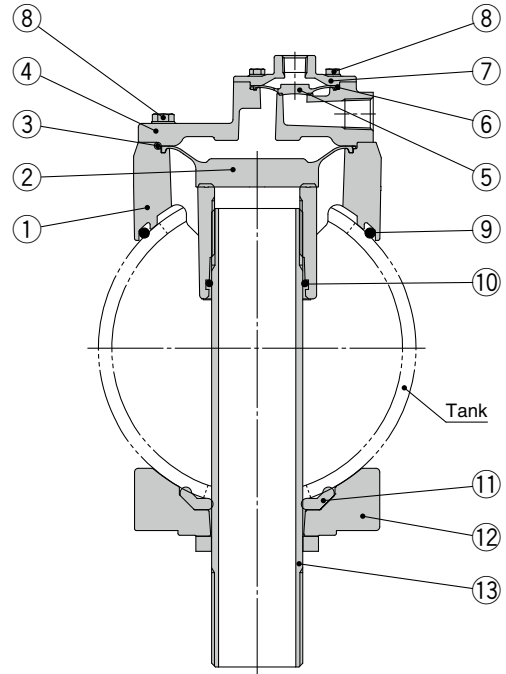

* The tank should be provided by the customer.

Component Parts

No.	Description	Material
1	Body	ADC
2	Main valve	Resin
3	O-ring	NBR
4	Bonnet	ADC
5	Sub-valve	Resin
6	O-ring	NBR
7	Bonnet	ADC
8	Hexagon bolt	Stainless steel
9	O-ring	NBR
10	O-ring	NBR
11	Gasket	NBR
12	Bottom support	ADC
13	Outlet pipe assembly	STKM + SS400

JSXFA Series

Dimensions: JSXFAE/Compression Fitting Type

Port size: Sizes 06, 10

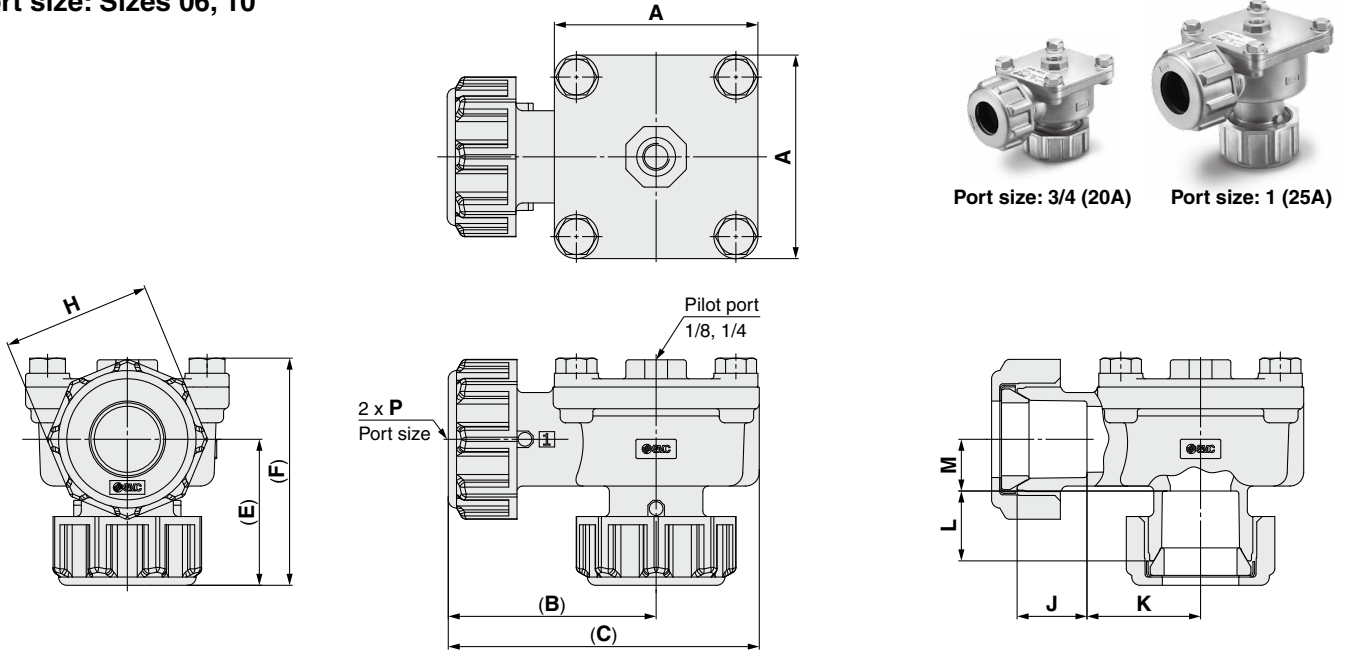

Port size: Size 14

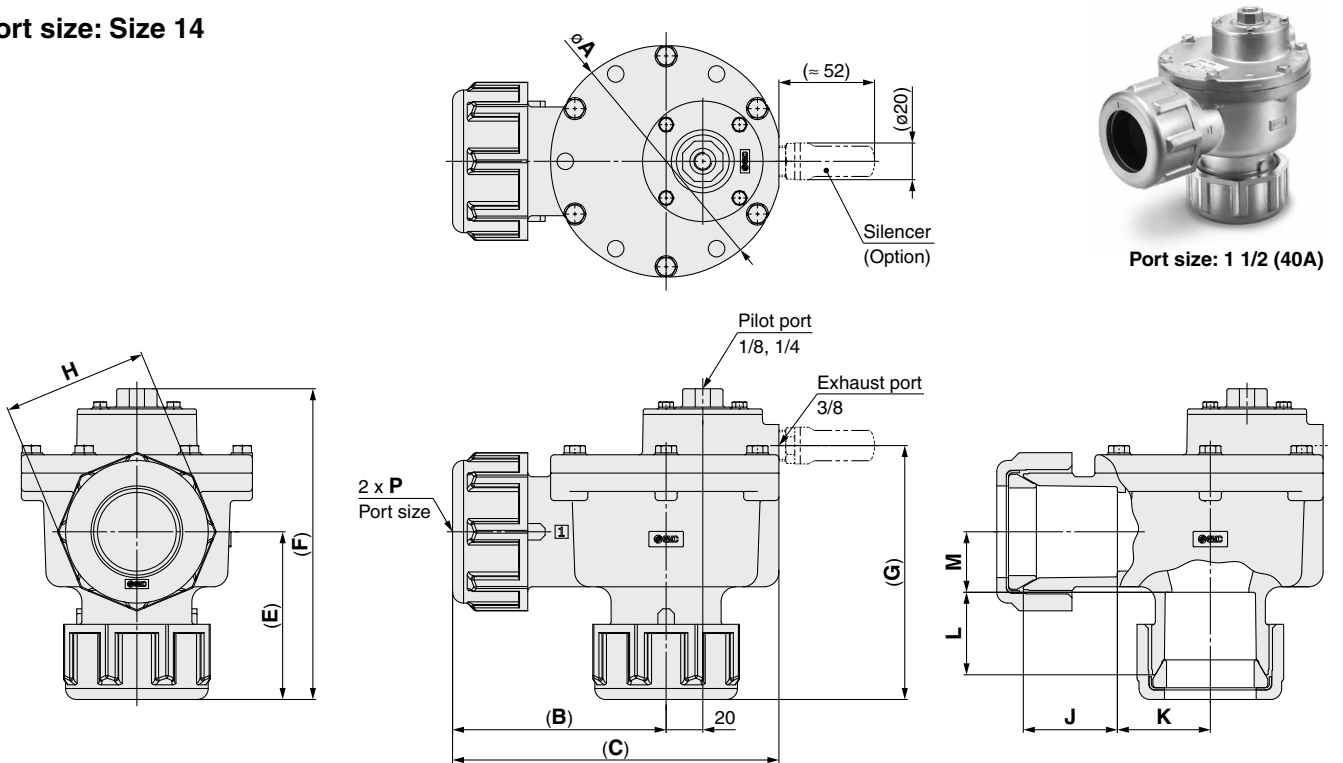

Dimensions

Model	Port size P	A	(B)	(C)	(E)	(F)	(G)	H	J	K	L	M
JSXFAE-06	3/4	74	76	113	54	83	—	54	25.4	41.3	25.4	18.8
JSXFAE-10	1	94	90	137	82	120	—	65	33.3	44.4	38.1	31.6
JSXFAE-14	1 1/2	126	117	178	92	170	139	80	51.3	50.7	45	33

Dimension in () shows the dimension after tightening.

Dimensions: JSXFAF/Direct Piping Type

Port size: Sizes 06, 10

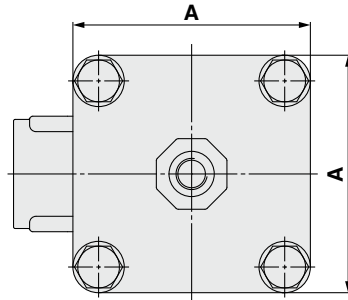

Port size: 3/4 (20A)



Port size: 1 (25A)

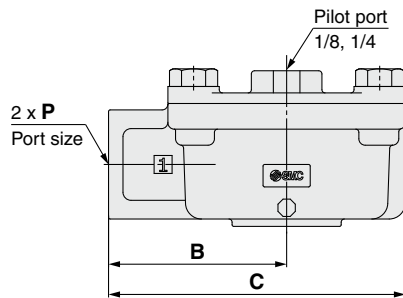
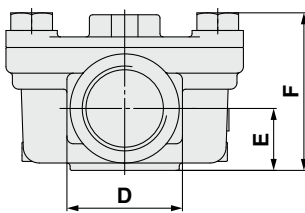

Port size: Size 14

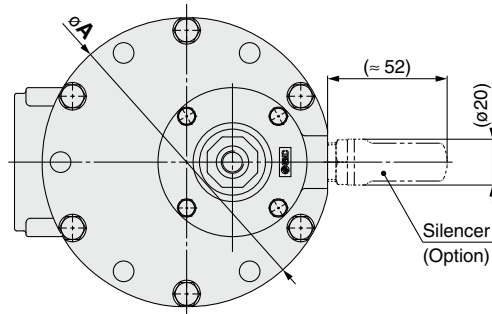

Port size: 1 1/2 (40A)

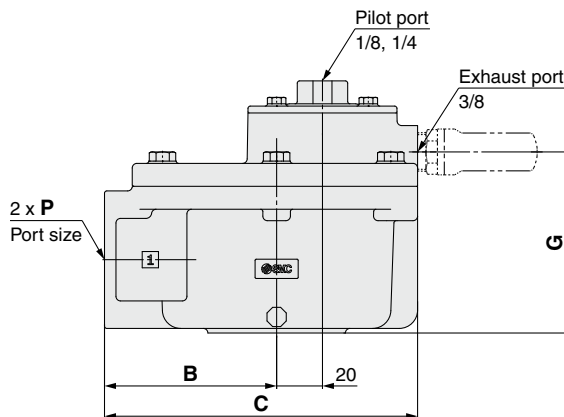
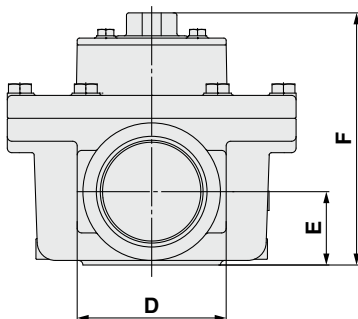

Dimensions

Model	Port size P	A	B	C	D	E	F	G
JSXFAP-06	3/4	74	55.5	92.5	36	19.3	48.8	—
JSXFAP-10	1	94	63.5	110.5	44	22.2	60.2	—
JSXFAP-14	1 1/2	126	75.1	136.6	65	32	110	79

[mm]

JSXFA Series

Dimensions: JSXFAH/Immersion Type

Port size: Size 06

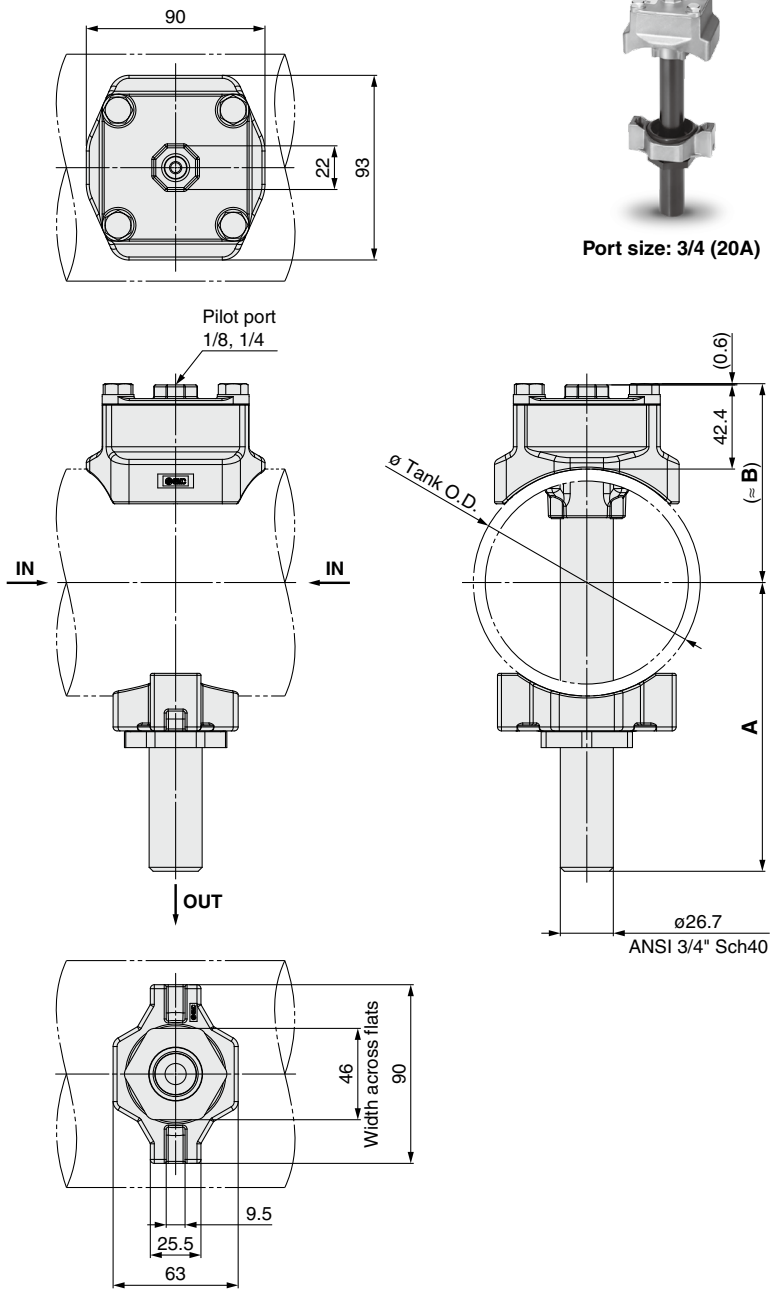

Recommended tank dimensions

* The tank should be provided by the customer.

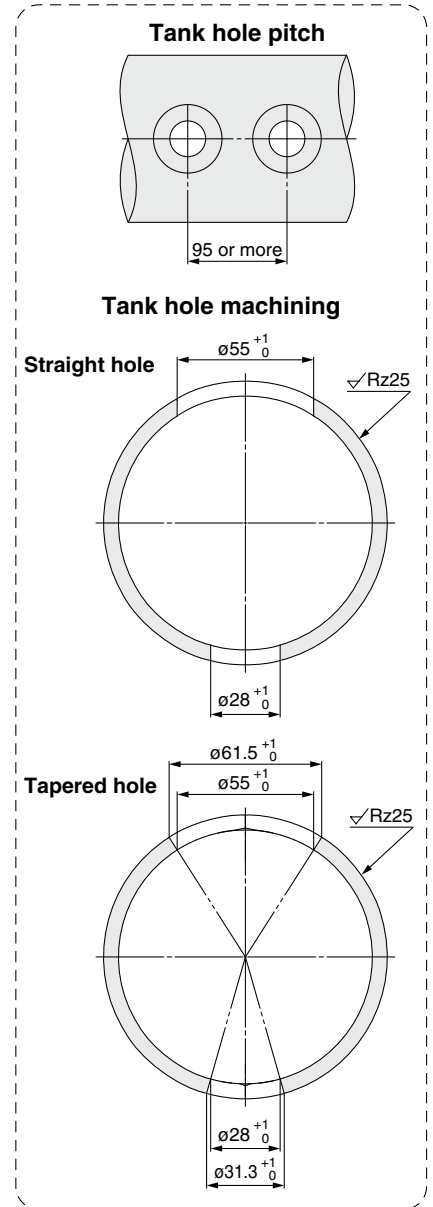

Dimensions

Tank size	Tank O.D. ø	B	OUT port piping configuration											
			1			2			3			4		
			A	D	E	A	D	E	A	D	E	A	D	E
4 inch (ANSI 4")	114.3 ^{+1.6} _{-0.6}	100	146 ±5	—	62	164 ±5	—	80	146 ±5	50	62	164 ±5	70	80
5 inch (ANSI 5")	141.3 ^{+1.6} _{-0.6}	114	153 ±5	—	56	173 ±5	—	76	153 ±5	50	56	173 ±5	70	76

Dimensions: JSXFAH/Immersion Type

Port size: Size 10

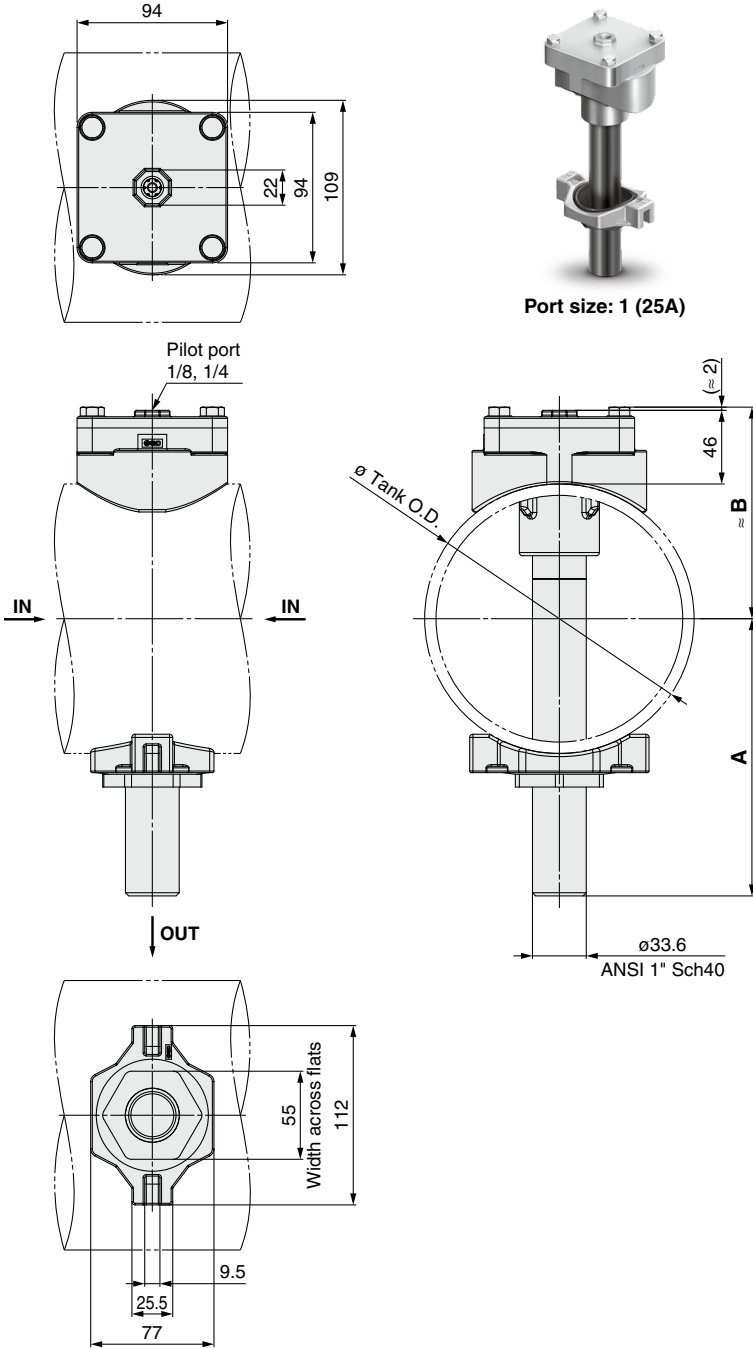

Recommended tank dimensions

* The tank should be provided by the customer.

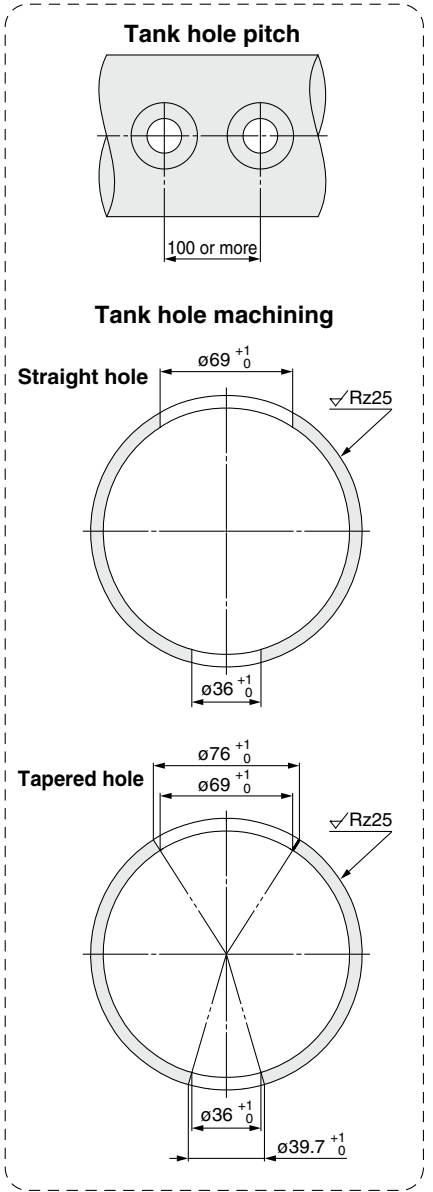

Dimensions

Tank size	Tank O.D. ϕ	B	OUT port piping configuration											
			1			2			3			4		
			A	D	E	A	D	E	A	D	E	A	D	E
5 inch (ANSI 5")	141.3 ^{+1.6} _{-0.8}	119	153 ±5	—	61	173 ±5	—	81	153 ±5	50	61	173 ±5	70	81
6 inch (ANSI 6")	168.3 ^{+1.6} _{-0.8}	132	173 ±5	—	68	213 ±5	—	108	173 ±5	50	68	213 ±5	90	108

JSXFA Series

Dimensions: JSXFAH/Immersion Type

Port size: Size 14

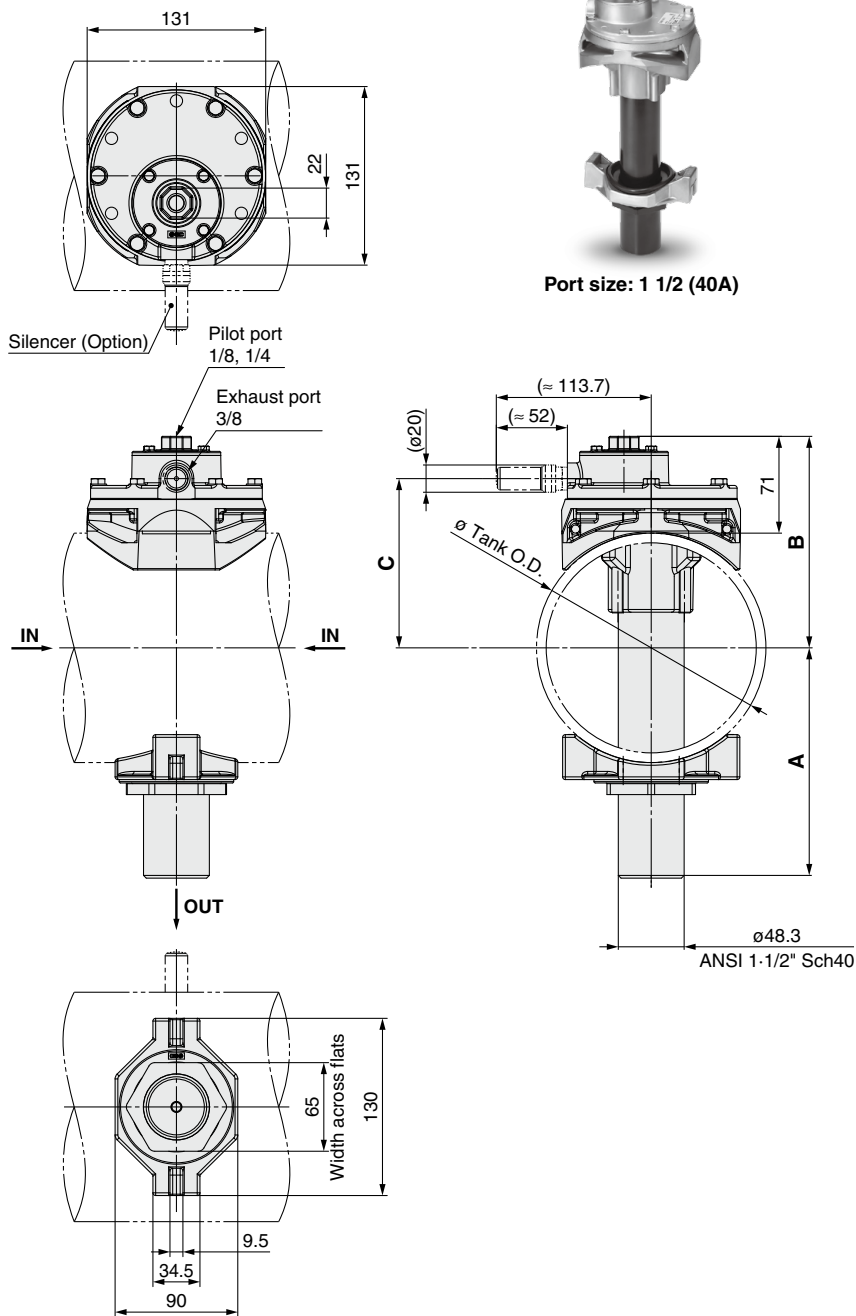

Recommended tank dimensions

* The tank should be provided by the customer.

Tank hole pitch

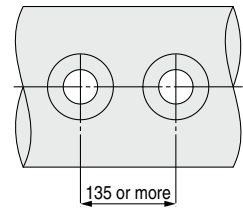

Tank hole machining

Straight hole

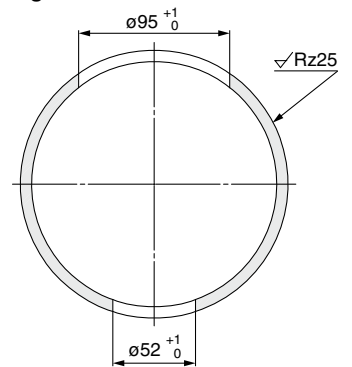

Tapered hole

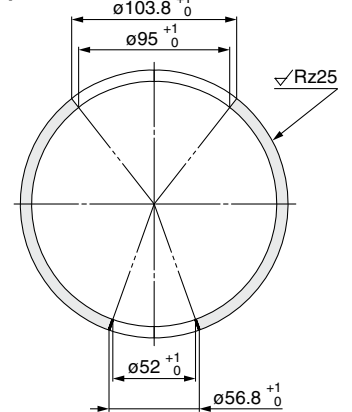

Dimensions

Tank size	Tank O.D. ø	B	C	OUT port piping configuration											
				1			2			3			4		
				A	D	E	A	D	E	A	D	E	A	D	E
6 inch (ANSI 6")	168.3 ^{+1.6} _{-0.9}	155	124	169 ±5	—	61	209 ±5	—	101	169 ±5	50	61	209 ±5	90	101
8 inch (ANSI 8")	219.1 ^{+1.6} _{-0.8}	181	150	198 ±5	—	65	258 ±5	—	125	198 ±5	50	65	258 ±5	110	125

Dimensions: JSXFAH/Immersion Type

Port size: Size 20

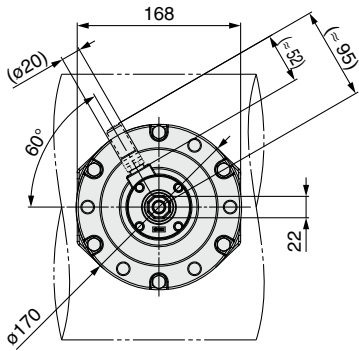

Port size: 2 (50A)

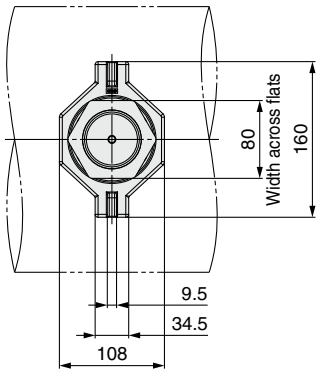
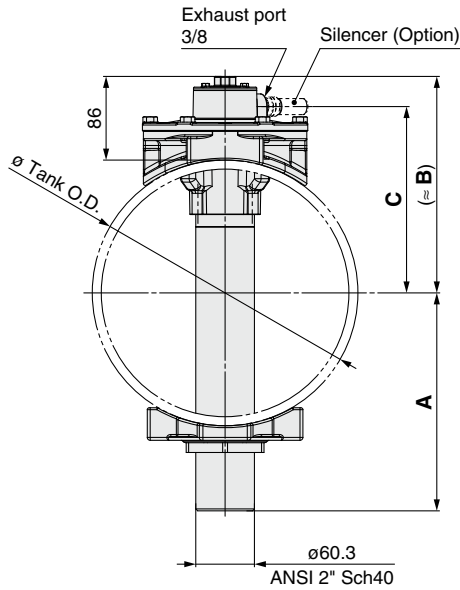
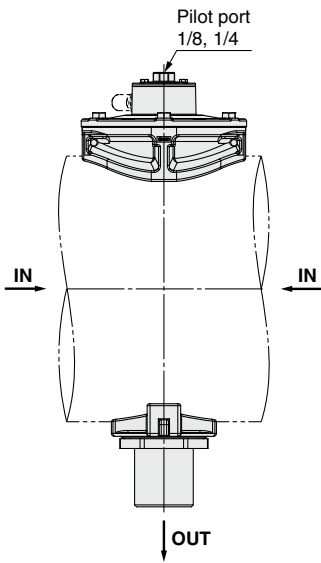

Recommended tank dimensions

* The tank should be provided by the customer.

Tank hole pitch

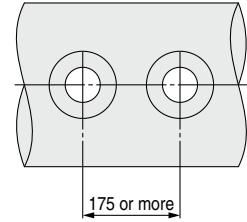

Tank hole machining

Straight hole

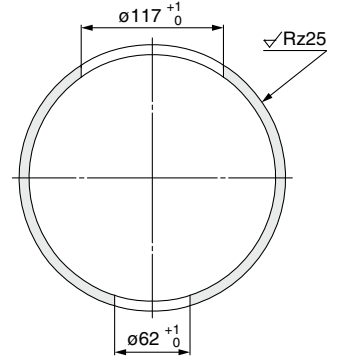

Tapered hole

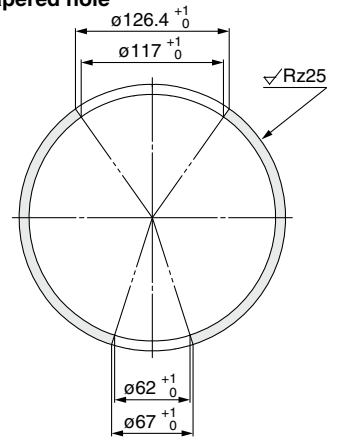

Dimensions

Tank size	Tank O.D. ø	B	C	OUT port piping configuration											
				1			2			3			4		
				A	D	E	A	D	E	A	D	E	A	D	E
8 inch (ANSI 8")	219.1 ^{+1.6} _{-0.8}	196	165	197 ±5	—	60	257 ±5	—	120	197 ±5	50	60	257 ±5	110	120
10 inch (ANSI 10")	273.1 ^{+2.4} _{-0.8}	223	192	224 ±5	—	60	284 ±5	—	120	224 ±5	50	60	284 ±5	110	120

--	--	--	--

Working Principle

Port size: Sizes 06, 10

De-energized

The air enters from the IN side goes through the supply orifice of the main valve to fill the pressure action chamber. The main valve is closed by the pressure built in the pressure action chamber.

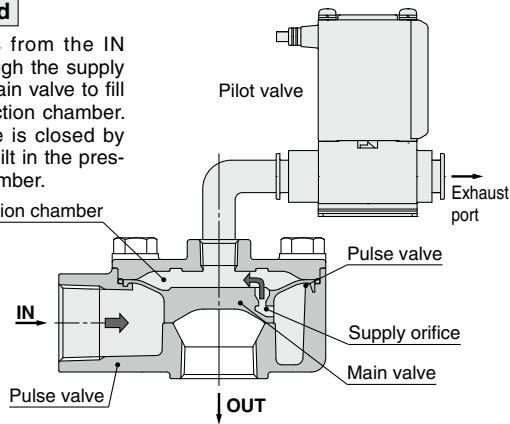

Right after energized

When the pilot valve is energized, the armature opens, and the air filling the pressure action chamber is released to the atmosphere through the pilot valve.

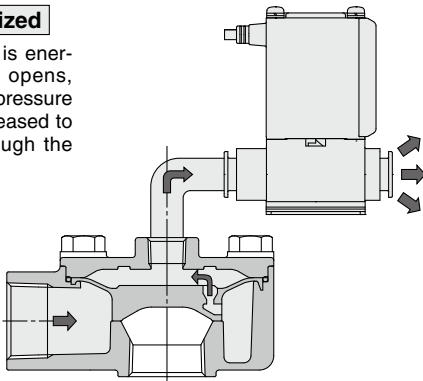

Energized (Main valve open)

Due to the release of air from the pilot valve to atmosphere, the pressure in the pressure action chamber decreases (force pushing the main valve down < force pushing the main valve up), opening the main valve. Because of this, the air flows to the OUT side.

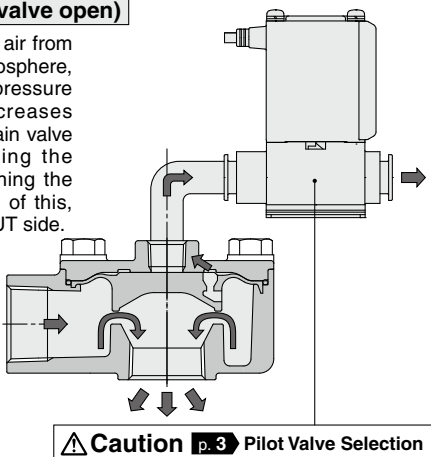

Port size: Size 14, 20

De-energized

The air enters from the IN side goes through the supply orifice of the main valve and sub-valve to fill the pressure action chamber. The main valve and sub-valve are closed by the pressure built in the pressure action chamber.

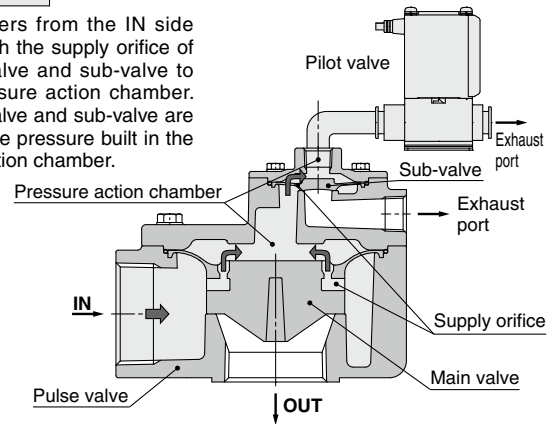

Right after energized

When the pilot valve is energized, the armature opens, and the air filling the pressure action chamber ① is released to the atmosphere through the pilot valve.

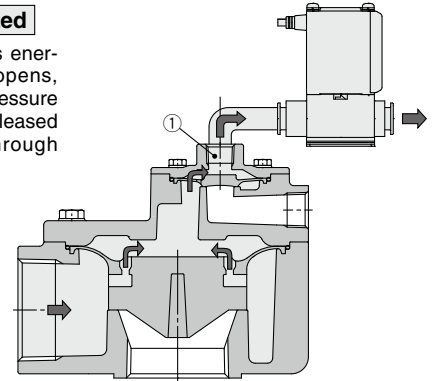

Energized (Sub-valve open)

Due to the release of air from the pilot valve to atmosphere, the pressure in the sub-valve pressure action chamber ① decreases (force pushing the sub-valve down < force pushing the sub-valve up), opening the sub-valve. Because of this, the air filling the pressure action chamber ② is released to the atmosphere from the exhaust port.

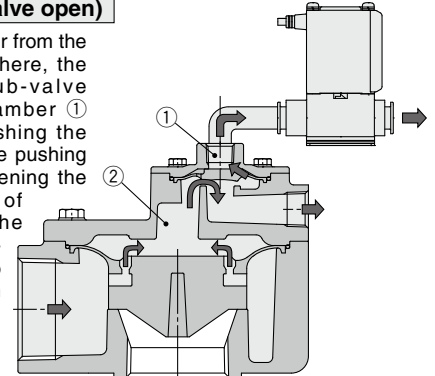

Energized (Main valve open)

Due to the release of air from the pressure action chamber ②, the pressure in the pressure action chamber ② decreases (force pushing the main valve down < force pushing the main valve up), opening the main valve. Because of this, the air flows to the OUT side of the pulse valve.

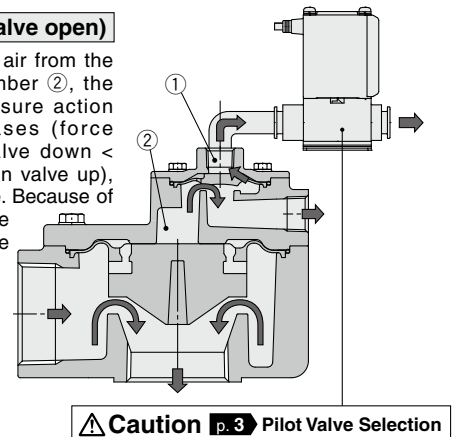

* The figure shows the JSXFAF.

Replacement Parts (JSXFA)

Size	Model	Replacement part number		
		Main valve assembly (Main valve + O-ring)	Sub-valve assembly (Sub-valve + O-ring)	Silencer
Port size: 06	JSXFA(E, F, H)□-06□-B-□	JSXF-06B-KT	—	—
	JSXFA(E, F, H)□-06□-B-□A	JSXF-06B-A-KT	—	—
Port size: 10	JSXFA(E, F, H)□-10□-B-□	JSXF-10B-KT	—	—
	JSXFA(E, F, H)□-10□-B-□A	JSXF-10B-A-KT	—	—
Port size: 14	JSXFA(E, F)□-14□-B-(S)□	JSXF-14B-KT	JSXF-14B-KT2	Rc, G thread: AN30-03 NPT thread: AN30-N03
	JSXFAH□-14□-B-(S)□	JSXF-14B-1-KT		
Port size: 20	JSXFAH□-20□-B-(S)□	JSXF-20B-KT	JSXF-14B-KT2	

Disassembly/Assembly Procedure

⚠ Caution

1. Before starting the disassembly work, be sure to shut off the power supply and pressure supply, and then release the residual pressure.

Disassembly

- 1) Loosen the hexagon bolts and remove the bonnet, O-ring, and main valve (sub-valve).

Assembly

- 1) Attach the main valve (sub-valve) to the body. The main valve (sub-valve) has a predetermined mounting direction. **Assemble the valve referring to Fig. 1.**
If the valve is assembled incorrectly, it can cause a malfunction.
- 2) Mount the O-ring to the body groove. (See Fig. 2.)
After mounting the O-ring, check to make sure that the O-ring is fitted properly in the groove. If it is not in the groove, external leakage and/or operation failure may occur.
- 3) Attach the bonnet to the body.
- 4) Tighten the hexagon bolts diagonally.
(See Table 1 for the tightening torque.)

Table 1 Proper Tightening Torque [N·m]

JSXFA□-06□	M8	12.5 to 13.8
JSXFA□-10□	M8	12.5 to 13.8
JSXFA□-14□	Main valve	M6 5.2 to 5.7
	Sub-valve	M4 1.5 to 1.7
JSXFA□-20□	Main valve	M8 12.5 to 13.8
	Sub-valve	M4 1.5 to 1.7

Port size:
06, 10

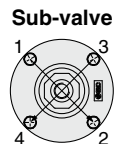
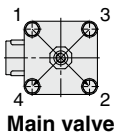

Port size:
14, 20

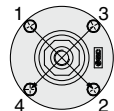
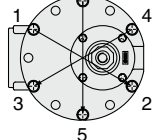

Port size: 06, 10

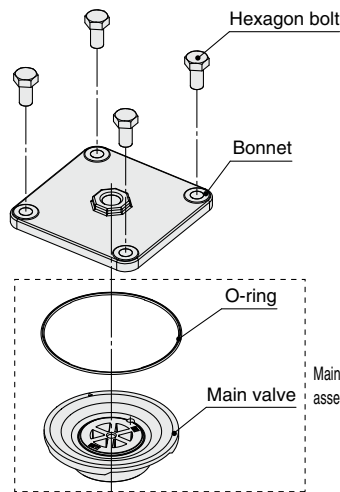

IN side

Port size: 14, 20

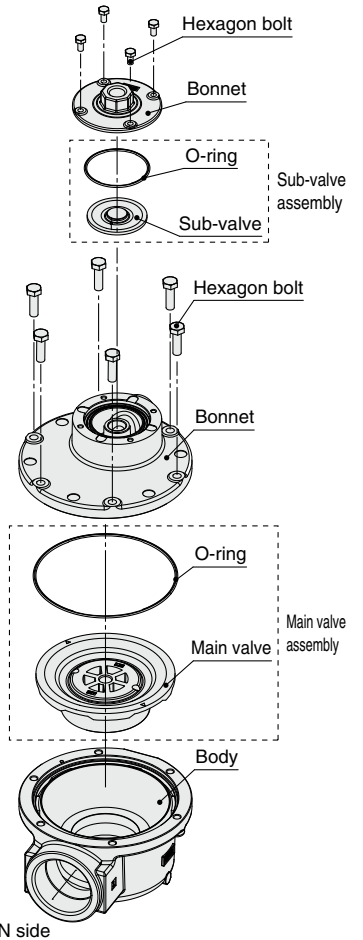

IN side

Fig. 2 O-ring position

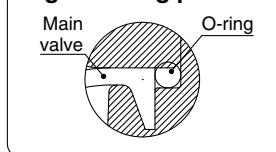
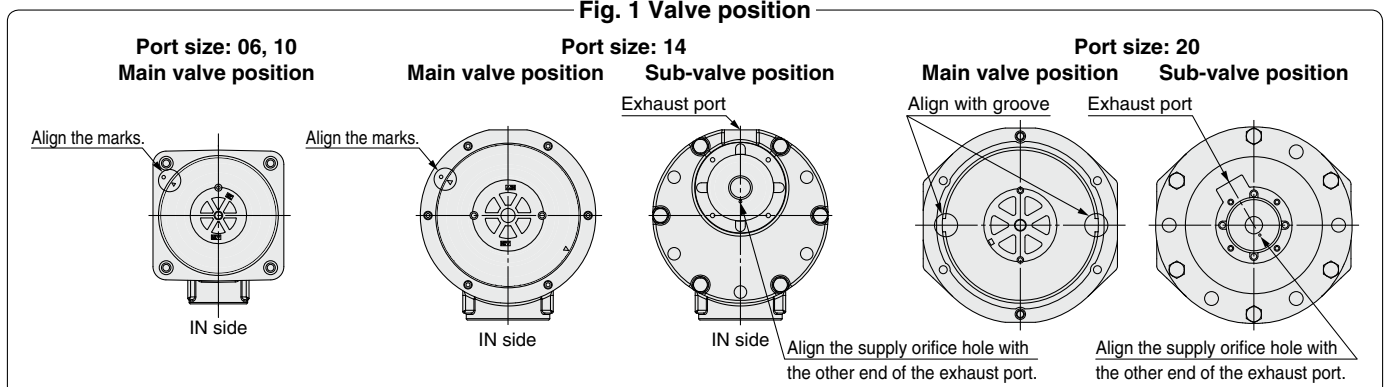

Fig. 1 Valve position



ATEX Compliant

Pulse Valve Valve for Dust Collector

55-JSXFA Series



CE Ex II 2 G Ex h IIB T6 Gb
II 2 D Ex h III B T72°C Db
-40°C ≤ Ta ≤ +60°C

How to Order

55-JSXFA **E** - **06** **R** - **B** - **1**

• ATEX category 2

① ② ③ ④ ⑤ ⑥

① Piping

E	Compression fitting type*1
F	Direct piping type

*1 Seals and washers are included.

④ Fluid and ambient temperatures

B	-40 to 60°C
----------	-------------

⑥ Pilot port size

Nil	1/4
1	1/8

② IN/OUT port size

06	3/4 (20A)
10	1 (25A)
14	1 1/2 (40A)

⑤ With/without silencer

		Port size		
		06	10	14
Nil	Without	●	●	●
S *2	With	—	—	●

*2 Port size: 14 only
Select Nil for 06 and 10.

Compression fitting type

Direct piping type

③ Thread type

R	Rc
N	NPT
F	G

Symbol

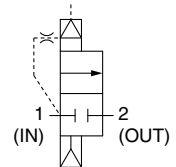

⚠ Caution

Pilot Valve Selection

For the pilot valve orifice diameter, $\phi 5$ mm or larger is recommended.

When the pilot orifice diameter is $\phi 3$ mm or larger and less than $\phi 5$ mm, put "A" to the end of the product number for made-to-order. The product may not operate correctly if the pilot valve orifice diameter is inadequate. (Port size: 3/4, 1) Depending on the pilot piping port size*1 or length, the valve may not operate correctly.

*1 The I.D. of the pilot piping must be larger than the pilot valve orifice diameter to use. The max. pilot piping I.D. is 10 mm.

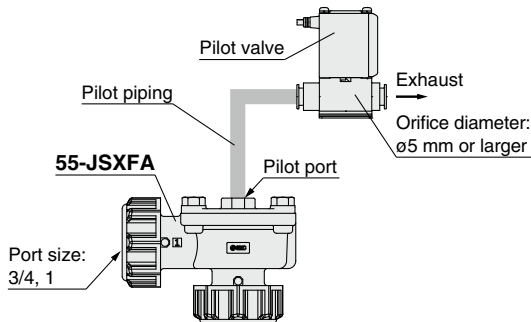

Made to Order

Pilot valve orifice diameter: Special specification

A	For $\phi 3$ mm to $\phi 5$ mm	Port size: 06, 10
----------	--------------------------------	-------------------

55-JSXFA - - **B** - **A**

Enter the standard product number.

Specifications

Series	55-JSXFA		
	06	10	14
Orifice diameter [mm]	$\phi 32$	$\phi 40$	$\phi 50$
Port size	3/4	1	1 1/2
Fluid	Air		
Min. operating pressure differential [MPa]	0.1		
Max. operating pressure differential [MPa]	0.9		
Max. system pressure [MPa]	0.9		
Fluid temperature [°C]	-40*1 to 60		
Ambient temperature [°C]	-40 to 60		
Weight [g]	Compression fitting type	470	910
	Direct piping type	290	500
		1850	1230

*1 No condensation

Replacement Parts

Size	Model	Replacement part number		
		Main valve assembly (Main valve + O-ring)	Sub-valve assembly (Sub-valve + O-ring)	Silencer
Port size: 06	55-JSXFA(E, F)-06□-B-□	J SXF-06B-KT	—	—
	55-JSXFA(E, F)-06□-B-□A	J SXF-06B-A-KT	—	—
Port size: 10	55-JSXFA(E, F)-10□-B-□	J SXF-10B-KT	—	—
	55-JSXFA(E, F)-10□-B-□A	J SXF-10B-A-KT	—	—
Port size: 14	55-JSXFA(E, F)-14□-B-□	J SXF-14B-KT	J SXF-14B-KT2	Rc, G thread: AN30-03 NPT thread : AN30-N03

Dedicated Controller for Operation / VXFC Series

How to Order Controller

VXFC 06 D

Number of output points	Voltage
06 6 output points	D 24 to 48 VDC
10 10 output points	D-6 12 VDC
	A*1 85 to 240 VAC

*1 "A" is not a CE marked product.

Specifications

Model	VXFC ⁰⁶ ₁₀ A	VXFC ⁰⁶ ₁₀ D	VXFC ⁰⁶ ₁₀ D-6
Input voltage	85 to 240 VAC	24 to 48 VDC	12 VDC
Output voltage	Same as input voltage		
Time setting	ON	0.01 to 0.99 s	
	OFF	0 to 299 s	
Time accuracy	±2%		
Number of outputs	6 to 10 points		
Operating ambient temperature	0 to 50°C (No condensation)		
Operating ambient humidity	45 to 80% (No condensation)		
Output current	0.5 A or less	0.5 A or less	0.5 A or less
Power supply fuse	3 A	1 A	1 A

[Application example]

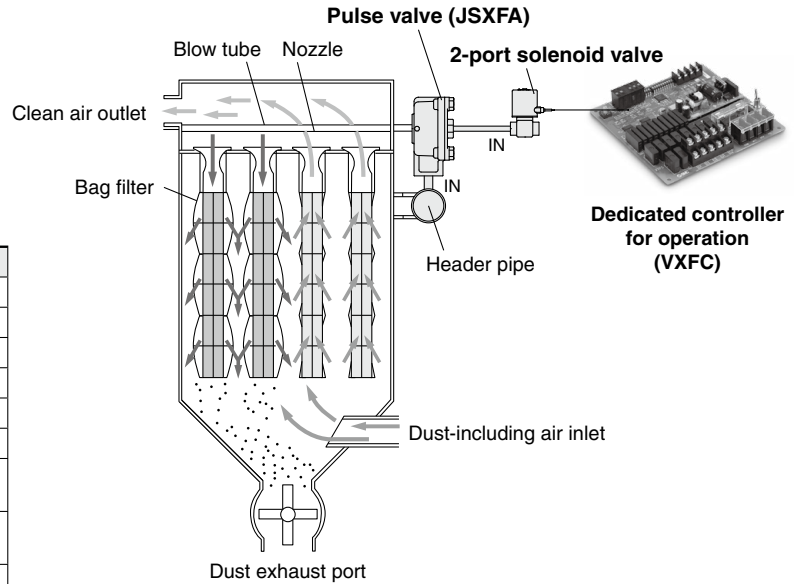

Two-time Hitting Function

A two-time hitting function has been adopted to improve the bag filter dusting efficiency. Turn ON the DIP switch for two-time hitting (OFF for one-time hitting).
(Effective for up to the number of set channels)

Operation sequence diagram

For 4 output points
Two-time hitting only for CH2
ON for 1 s
OFF for 2 s

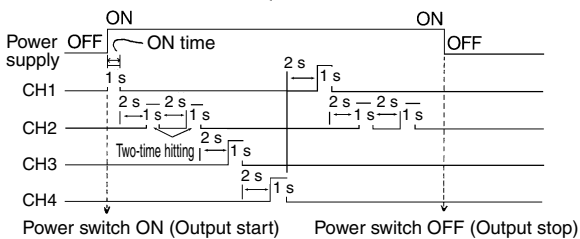

Interrupt Operation Function

Interrupting an operation via an external switch is possible using input signals.

Operation sequence diagram

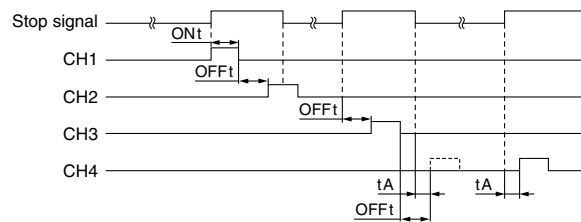

Cascade Connection (Multiple-board connection)

VXFC10: One board only allows 10 output points max., but the points can be increased to 20 or 30 output points by connecting cascades.

Connection

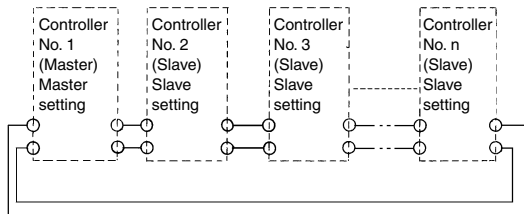

Operation sequence diagram

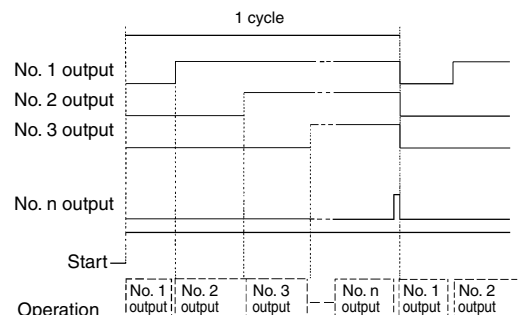

Dimensions

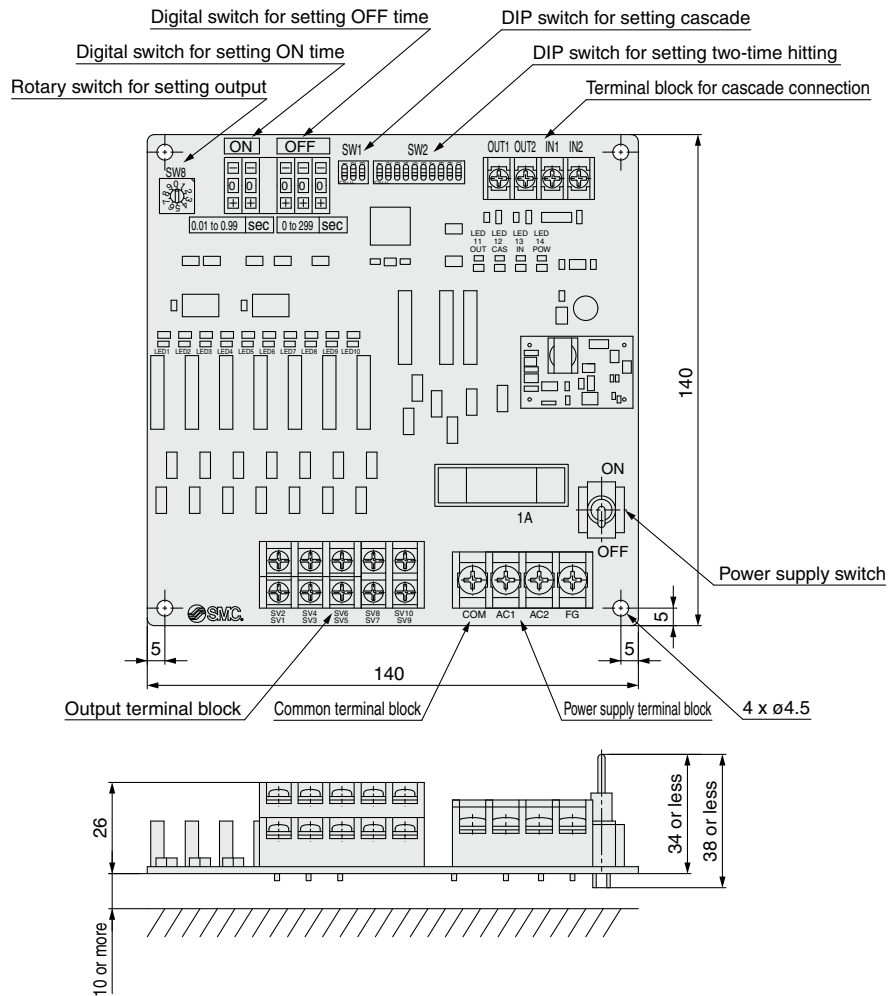

JSXFA series / Glossary of Terms

Pressure Terminology

- 1. Maximum operating pressure differential**
The maximum pressure differential (the difference between the inlet and outlet pressure) which is allowed for operation. When the outlet pressure is 0 MPa, this becomes the maximum operating pressure.
- 2. Minimum operating pressure differential**
The minimum pressure differential (the difference between the inlet pressure and outlet pressure) required to keep the main valve fully open.
- 3. Maximum system pressure**
The maximum pressure that can be applied inside the pipelines (line pressure).
[The pressure differential of the solenoid valve portion must not exceed the maximum operating pressure differential.]

Other

- 1. Symbol**
In the symbol () , when the valve is closed, flow is blocked from port 1 to port 2. However, if the pressure in port 2 is higher than port 1, the valve will not be able to block the fluid and it will flow from port 2 to port 1.



JSXFA Series Specific Product Precautions 1

Be sure to read this before handling the products. Refer to the back cover for safety instructions. For 2-port solenoid valve for fluid control precautions, refer to the “Handling Precautions for SMC Products” and the “Operation Manual” on the SMC website.

Design

⚠Warning

1. Cannot be used as an emergency shutoff valve, etc.

The valves presented in this catalog are not designed for safety applications such as an emergency shutoff valve. If the valves are used in this type of system, other reliable safety assurance measures should also be adopted.

2. Continuous valve open

The valve is for pulse operation. Do not open the valve continuously. Since a large amount of air is consumed, the diaphragm will oscillate (chatter) due to insufficient air supply on the inlet side, and this can lead to failure.

Silencer

⚠Caution

1. The silencer's response properties do not change in the initial stage, but will change due to the blockage after long use. Replace it after using about 500,000 times. This number is subject to change based on fluid quality and energizing time.

2. When using a silencer, make space for silencer replacement.

Selection

⚠Warning

1. Air quality

1. Use clean air.

Do not use compressed air that contains chemicals, synthetic oils that include organic solvents, salt, corrosive gases, etc., as it can cause damage or malfunction.

2. Install an air filter.

Install an air filter upstream near the valve. Select an air filter with a filtration size of 5 μm or smaller.

3. Install an aftercooler, air dryer, etc.

Compressed air that contains excessive drainage may cause the malfunction of valves and other pneumatic equipment. To prevent this, install an aftercooler, air dryer, etc.

4. If excessive carbon powder is generated, eliminate it by installing mist separators on the upstream side of valves.

If excessive carbon powder is generated by the compressor, it may adhere to the inside of the valves and cause malfunction.

For compressed air quality, refer to the Best Pneumatics No. 6 catalog.

2. Ambient environment

Use within the operable ambient temperature range. Confirm the compatibility between the product's composition materials and the ambient atmosphere. Be certain that the fluid used does not touch the external surface of the product.

Selection

⚠Warning

3. Countermeasures against static electricity

Take measures to prevent static electricity, since some fluids can cause static electricity.

4. Low temperature operation

1. The valve can be used in fluid temperatures down to -40°C . However, take measures to prevent the freezing or solidification of impurities, etc.
2. The installation of a dryer, retaining the heat of the body, etc., is recommended to prevent a freezing condition in which the dew point temperature is high and the ambient temperature is low, or the high flow is running.

5. Fluid properties

Use a general compressed air with a filter of 5 μm or less mounted on the inlet of the piping. (Excluding dry air)

⚠Caution

1. Leakage voltage

When the solenoid valve is operated using the controller, etc., the leakage voltage should be the product allowable leakage voltage or less. Particularly when using a resistor in parallel with a switching element and using a C-R element (surge voltage suppressor) to protect the switching element, take note that leakage current will flow through the resistor, C-R element, etc., creating a possible danger that the valve may not turn off.

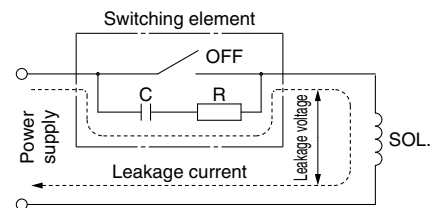

AC coil: 5% or less of rated voltage
DC coil: 2% or less of rated voltage

Mounting

⚠Warning

1. If air leakage increases or equipment does not operate properly, stop operation.

After mounting is completed, confirm that it has been done correctly by performing a suitable function test.

2. Avoid sources of vibration, or change the fixing method to avoid resonance.

3. Painting and coating

Warnings or specifications printed or labeled on the product should not be erased, removed, or covered up.



JSXFA Series Specific Product Precautions 2

Be sure to read this before handling the products. Refer to the back cover for safety instructions. For 2-port solenoid valve for fluid control precautions, refer to the "Handling Precautions for SMC Products" and the "Operation Manual" on the SMC website.

Piping

Warning

- During use, deterioration of the tubes or damage to the fittings could cause the tubes to come loose from their fittings and thrash about.**
To prevent uncontrolled tube movement, install protective covers or fasten tubes securely in place.
- Do not use the compression fitting of the valve to support the piping. The piping could disconnect from the valve. Be sure to mount the valve to secured piping. (Compression fittings do not have a valve-holding function.)**

Caution

- Use a steel tube for the IN and OUT piping.**
- Preparation before piping**
Before piping is connected, it should be thoroughly blown out with air (flushing) or washed to remove chips, cutting oil, and other debris from inside the pipe.
Install piping so that it does not apply pulling, pressing, bending, or other forces on the valve body.
- Avoid connecting ground lines to piping, as this may cause electric corrosion in the system.**
- Always tighten threads with the proper tightening torque.**
When attaching fittings to valves, tighten with the proper tightening torque as shown below.

Tightening Torque for Piping

Connection thread	Proper tightening torque [N·m]
1/4	12 to 14
3/8	22 to 24
1/2	28 to 30
3/4	28 to 30
1	36 to 38
1 1/2	40 to 42

5. Tightening of the compression nut

Be sure to tighten the compressor nut sufficiently to prevent the nut from loosening and to prevent leakage from occurring.

Wrench Tightening Angle after Hand-tightening (Guide for tightening the nut)

Size	Wrench tightening angle
3/4 (20A)	90° to 270°
1 (25A)	135° to 315°
1 1/2 (40A)	150° to 330°

- * Mount the valve to secured piping.
- * Insert the piping until it stops to prevent the piping from going in slanted.
- * Do not expose the piping to oil or moisture. Otherwise, the valve may come off easily.
- * Sealing performance will decrease due to the deterioration of seals. Tighten the compression nut regularly.

Cross section of the nut

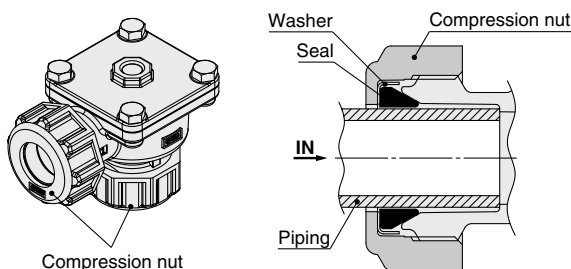

Caution

6. Installation of the immersion type

Tighten and check the pipe assembly sufficiently to prevent leakage, looseness, and play.

- Insert the pipe assembly into the OUT port of the valve assembly and screw it in vertically. (Inserting the pipe at an angle may damage the O-ring inside the valve.)
- Continue tightening the pipe assembly until the body and the bottom support touch the tank.

Tighten with a wrench or other tool so that the bottom support does not rotate.

Pipe assembly tightening guide (Tightening torque)

Size	Tightening torque [N·m]
3/4 (20A)	30
1 (25A)	50
1 1/2 (40A)	50
2 (50A)	120

- * Excessive tightening may damage the valve or deform or damage the tank.
- * The pipe assembly may become loose due to vibration when discharging air.
Perform periodic retightening.
- * The recommended tank is the ANSI shc40. If making your own tank, ensure that it has sufficient strength to prevent it from becoming deformed when the valve is being screwed in.

Tank assembly instructions

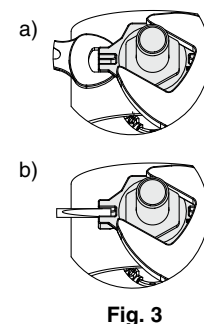
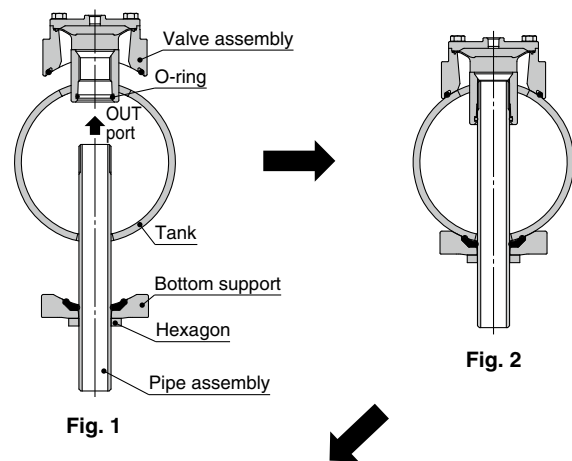

- ① Secure the bottom support with a wrench. Refer to a). (It can also be secured like in b).) When securing, align the tank with the curved surface of the bottom support.
- ② Tighten the hexagonal part of the pipe assembly with a wrench.



JSXFA Series

Specific Product Precautions 3

Be sure to read this before handling the products. Refer to the back cover for safety instructions. For 2-port solenoid valve for fluid control precautions, refer to the “Handling Precautions for SMC Products” and the “Operation Manual” on the SMC website.

Piping

Caution

- 7. When connecting piping to a product**
Avoid mistakes regarding the supply port, etc.
- 8. If a regulator, or a restrictor, is installed immediately before or after the IN port of the valve, the main valve may oscillate (chatter). Install them away from the valve or change the restriction.**
- 9. The header tank capacity should be sufficient. (Install a sufficient air volume immediately upstream from the IN side) This is a valve for large flow rate, so if the capacity is small, the main valve may not open or may oscillate due to pressure drop or insufficient air supply.**

Operating Environment

Warning

- 1. Do not use in an atmosphere containing corrosive gases, chemicals, sea water, water vapor, or where there is direct contact with any of these.**
- 2. The standard model cannot be used in explosive atmospheres. For use in explosive atmospheres, select the 55-JSXFA. (Refer to page 15.)**
- 3. Do not use in locations subject to vibration or impact.**
- 4. Do not use in locations where radiated heat will be received from nearby heat sources.**
- 5. Employ suitable protective measures in locations where there is contact with oil, welding spatter, etc.**

Maintenance

Warning

- 1. Removal of product**
The valve becomes hot depending on the fluid temperature. Confirm that the valve temperature has dropped sufficiently before performing work. If touched inadvertently, there is a danger of being burned.
 1. Shut off the fluid supply and release the fluid pressure in the system.
 2. Shut off the power supply.
 3. Dismount the product.
- 2. Low frequency operation**
Switch valves at least once every 30 days to prevent malfunction. Also, in order to use them under the optimum state, conduct a regular inspection biannually.
- 3. Disassembly**
Do not disassemble for purposes other than the main valve replacement, or malfunction may occur.
Refer to the Disassembly/Assembly Procedure on page 14 for the replacement of the main valve.

Maintenance

Caution

- 1. Filters**
 1. Be careful regarding clogging of filters.
 2. Replace filter elements after one year of use, or earlier if the pressure drop reaches 0.1 MPa.
- 2. Storage**
In case of long term storage after use, thoroughly remove all moisture to prevent rust, the deterioration of rubber materials, etc.
- 3. Exhaust the drainage from air filters periodically.**

Appearance

Caution

- 1. Surface treatment is applied to the product to improve corrosion resistance. There may be spot pattern on the surface depending on the treatment condition, but there is no problem in use.**

Dedicated Controller for Operation VXFC Series

Wiring

Warning

- 1. The controller starts its output the moment the power switch is turned ON. Be aware that even if the power switch is turned OFF, power is connected to the terminal block.**

Caution

- 1. Make sure that the power supply voltage to be input matches the voltage in the controller's specifications. The power supply voltage that has been input becomes the voltage that is output to the solenoid valves.**
- 2. Connect a ground that is rated Class 3 or greater to the power supply terminal block's FG.**
- 3. If the power source is DC, use caution to its polarity. If the polarity is incorrect, it may result in a malfunction or damage.**
- 4. For details, refer to the separate Operation Manual.**
- 5. The solenoid valve mounted on the controller should be equipped with a surge voltage suppressor.**

Operating Environment

Warning

- 1. Operate under conditions that are free of vibration and impact.**
- 2. Operate in an ambient temperature range between 0°C and 50°C.**
- 3. Operate in an ambient humidity range between 45% to 80% (no condensation).**

Safety Instructions

These safety instructions are intended to prevent hazardous situations and/or equipment damage. These instructions indicate the level of potential hazard with the labels of “**Caution**,” “**Warning**” or “**Danger**.” They are all important notes for safety and must be followed in addition to International Standards (ISO/IEC)*1), and other safety regulations.

 **Caution:** **Caution** indicates a hazard with a low level of risk which, if not avoided, could result in minor or moderate injury.

 **Warning:** **Warning** indicates a hazard with a medium level of risk which, if not avoided, could result in death or serious injury.

 **Danger :** **Danger** indicates a hazard with a high level of risk which, if not avoided, will result in death or serious injury.

*1) ISO 4414: Pneumatic fluid power – General rules relating to systems.
ISO 4413: Hydraulic fluid power – General rules relating to systems.
IEC 60204-1: Safety of machinery – Electrical equipment of machines.
(Part 1: General requirements)
ISO 10218-1: Manipulating industrial robots – Safety.
etc.

Warning

1. The compatibility of the product is the responsibility of the person who designs the equipment or decides its specifications.

Since the product specified here is used under various operating conditions, its compatibility with specific equipment must be decided by the person who designs the equipment or decides its specifications based on necessary analysis and test results. The expected performance and safety assurance of the equipment will be the responsibility of the person who has determined its compatibility with the product. This person should also continuously review all specifications of the product referring to its latest catalog information, with a view to giving due consideration to any possibility of equipment failure when configuring the equipment.

2. Only personnel with appropriate training should operate machinery and equipment.

The product specified here may become unsafe if handled incorrectly. The assembly, operation and maintenance of machines or equipment including our products must be performed by an operator who is appropriately trained and experienced.

3. Do not service or attempt to remove product and machinery/equipment until safety is confirmed.

1. The inspection and maintenance of machinery/equipment should only be performed after measures to prevent falling or runaway of the driven objects have been confirmed.
2. When the product is to be removed, confirm that the safety measures as mentioned above are implemented and the power from any appropriate source is cut, and read and understand the specific product precautions of all relevant products carefully.
3. Before machinery/equipment is restarted, take measures to prevent unexpected operation and malfunction.

4. Contact SMC beforehand and take special consideration of safety measures if the product is to be used in any of the following conditions.

1. Conditions and environments outside of the given specifications, or use outdoors or in a place exposed to direct sunlight.
2. Installation on equipment in conjunction with atomic energy, railways, air navigation, space, shipping, vehicles, military, medical treatment, combustion and recreation, or equipment in contact with food and beverages, emergency stop circuits, clutch and brake circuits in press applications, safety equipment or other applications unsuitable for the standard specifications described in the product catalog.
3. An application which could have negative effects on people, property, or animals requiring special safety analysis.
4. Use in an interlock circuit, which requires the provision of double interlock for possible failure by using a mechanical protective function, and periodical checks to confirm proper operation.

Caution

1. The product is provided for use in manufacturing industries.

The product herein described is basically provided for peaceful use in manufacturing industries.
If considering using the product in other industries, consult SMC beforehand and exchange specifications or a contract if necessary.
If anything is unclear, contact your nearest sales branch.

Limited warranty and Disclaimer/ Compliance Requirements

The product used is subject to the following “Limited warranty and Disclaimer” and “Compliance Requirements”.

Read and accept them before using the product.

Limited warranty and Disclaimer

1. The warranty period of the product is 1 year in service or 1.5 years after the product is delivered, whichever is first.*2)
Also, the product may have specified durability, running distance or replacement parts. Please consult your nearest sales branch.
2. For any failure or damage reported within the warranty period which is clearly our responsibility, a replacement product or necessary parts will be provided.
This limited warranty applies only to our product independently, and not to any other damage incurred due to the failure of the product.
3. Prior to using SMC products, please read and understand the warranty terms and disclaimers noted in the specified catalog for the particular products.

*2) Vacuum pads are excluded from this 1 year warranty.

A vacuum pad is a consumable part, so it is warranted for a year after it is delivered.
Also, even within the warranty period, the wear of a product due to the use of the vacuum pad or failure due to the deterioration of rubber material are not covered by the limited warranty.

Compliance Requirements

1. The use of SMC products with production equipment for the manufacture of weapons of mass destruction (WMD) or any other weapon is strictly prohibited.
2. The exports of SMC products or technology from one country to another are governed by the relevant security laws and regulations of the countries involved in the transaction. Prior to the shipment of a SMC product to another country, assure that all local rules governing that export are known and followed.

Caution

SMC products are not intended for use as instruments for legal metrology.

Measurement instruments that SMC manufactures or sells have not been qualified by type approval tests relevant to the metrology (measurement) laws of each country. Therefore, SMC products cannot be used for business or certification ordained by the metrology (measurement) laws of each country.

Revision History

Edition B	* An immersion type has been added. * The ATEX compliant 55-JSXFA series has been added. * Number of pages has been increased from 16 to 20.	YT
Edition C	* 3/4 (20A), 1 1/2 (40A), and 2 (50A) port sizes have been added to the immersion type. * Number of pages has been increased from 20 to 24.	ZY

Safety Instructions

Be sure to read the “Handling Precautions for SMC Products” (M-E03-3) and “Operation Manual” before use.