

# Series MXP ø6

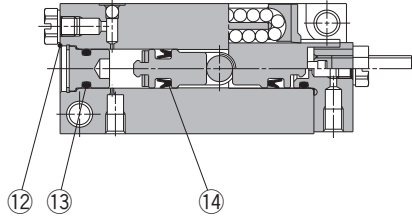

## Construction

### MXP6



\* The numbers are the same as the "Construction" of the Best Pneumatics No.3 Series MXP.

#### Seal Kit List

No.	Description	Material	Note
⑫	Gasket (for plug)	PVC	
⑬	O-ring	NBR	
⑭	Piston seal		

#### Replacement Parts: Seal Kit

Bore size (mm)	Kit no.	Contents
6	MXP6-PS	A set of two of ⑫, ⑬ and ⑭ each

#### Replacement Parts: Grease Pack

Applied unit	Grease pack part no.
Guide unit	GR-S-010 (10 g)
	GR-S-020 (20 g)
Cylinder unit	GR-L-005 (5 g)
	GR-L-010 (10 g)

### MXPJ6

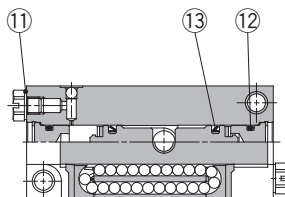

\* The numbers are the same as the "Construction" of the Best Pneumatics No.3 Series MXP.

#### Seal Kit List

No.	Description	Material	Note
⑪	Gasket (for plug)	PVC	
⑫	O-ring	NBR	
⑬	Piston seal		

#### Replacement Parts: Seal Kit

Bore size (mm)	Kit no.	Contents
6	MXPJ6-PS	2 pieces of no. ⑪, ⑫ and ⑬

#### Replacement Parts: Grease Pack

Applied unit	Grease pack part no.
Guide unit	GR-S-010 (10 g)
	GR-S-020 (20 g)
Cylinder unit	GR-L-005 (5 g)
	GR-L-010 (10 g)

# Series MXP

ø8, ø10, ø12, ø16

Replacement  
Procedure is  
P.326

## Construction

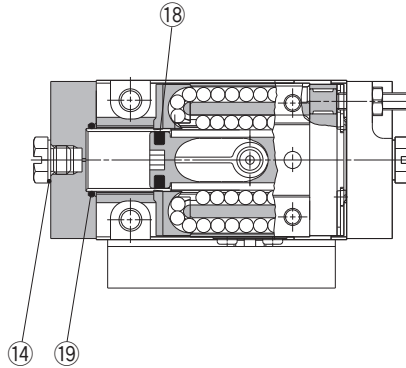

\* The numbers are the same as the "Construction" of the Best Pneumatics No.3 Series MXP.

### Seal Kit List

No.	Description	Material	Note
14	<b>Gasket (for plug)</b>	NBR, stainless steel	
18	<b>Piston seal</b>	NBR	
19	<b>O-ring</b>		

### Replacement Parts: Seal Kit

Bore size (mm)	Kit no.	Contents
8	MXP8-PS	A set of two of 14, 18 and 19 each
10	MXP10-PS	
12	MXP12-PS	
16	MXP16-PS	

### Replacement Parts: Grease Pack

Applied unit	Grease pack part no.
Guide unit	GR-S-010 (10 g)
	GR-S-020 (20 g)
Cylinder unit	GR-L-005 (5 g)
	GR-L-010 (10 g)

Actuators

Modular F.R.L.  
Pressure Control Equipment

Air Preparation  
Equipment

Industrial Filters

Replacement  
Procedure

Actuators

Modular F.R.L.  
Pressure Control Equipment

Industrial Filters