

Series CKQGM/CKQPM

Replacement
Procedure is
p.374

Construction

CKQGM50

* The below figures indicate the CKQGM50-□RAL.

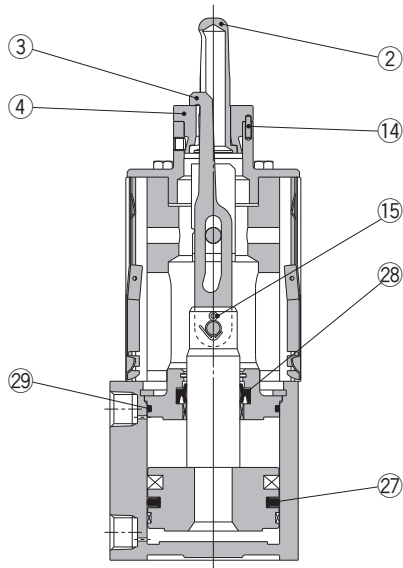

* There's no seal kit for CKQGM50.

CKQPM50

* The below figures indicate the CKQPM50-□RAL.

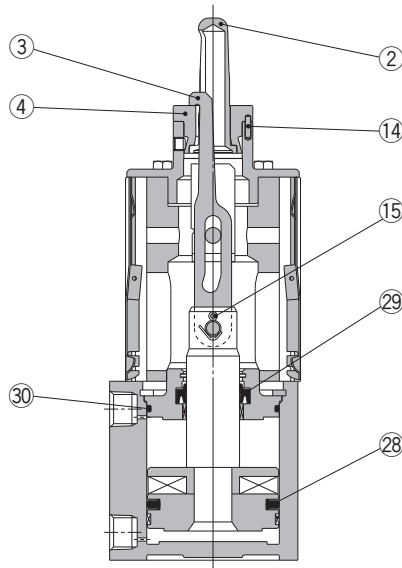

* There's no seal kit for CKQPM50.

* The numbers are the same as the "Construction" of the Best Pneumatics No.3 Series CKQ□M/CLKQ□M.

Seal Kit List

No.	Description	Material	Note
27	Piston seal	NBR	
28	Rod seal		
29	Tube gasket		

Replacement Parts: Seal Kit

Kit no.	Content
CQ2B50-PS	Set of nos. above. 27, 28, 29

* Consult SMC for maintenance service. Seal kit for maintenance of the CLKQ□ series with lock is not available.

Replacement Parts: Grease Pack

Grease pack part no.	Content
GR-S-010	Grease 10 g (Lithium)

* Consult SMC when replacing the actuating cylinders.

Seal Kit List

No.	Description	Material	Note
28	Piston seal	NBR	
29	Rod seal		
30	Tube gasket		

Replacement Parts: Seal Kit

Kit no.	Content
CQ2B50-PS	Set of nos. above. 28, 29, 30

* Consult SMC for maintenance service. Seal kit for maintenance of the CLKQ□ series with lock is not available.

Replacement Parts: Grease Pack

Grease pack part no.	Content
GR-S-010	Grease 10 g (Lithium)

* Consult SMC when replacing the actuating cylinders.

Guide Pins Assembly List

No.	Description	Material	Note
2, 4	Guide pins assembly	Stainless steel	
14	Parallel pin	Tool steel	

* Refer to page 183 for the guide pins assembly.

Clamp Arm Assembly List

No.	Description	Material	Note
3	Clamp arm	Structural steel	
15	Cotter pin	Stainless steel	