

Construction

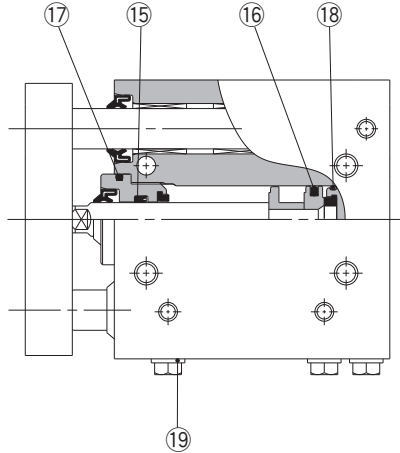

* The numbers are the same as the "Construction" of the Best Pneumatics No.2 Series HYG.

Seal Kit List

No.	Description	Material	Note
15	Rod seal	NBR	(FKM can be selected.)
16	Piston seal	NBR	
17	O-ring (Rod end)	NBR	(FKM can be selected.)
18	O-ring (Head end)	NBR	
19	Seal washer	Stainless steel + NBR	(FKM can be selected.)

18 is a non-replaceable part, so it is not included in the seal kit.

Replacement Parts: Seal Kit

Bore size (mm)	Kit no.	Contents
20	HYG20□-PS	Set of left nos. 15, 16, 17, 19.
25	HYG25□-PS	
32	HYG32□-PS	

Place the seal material symbol in □.

Symbol	Material
R	NBR
H	External FKM*

* External seal: Rod seal, O-ring (Rod side) and seal washer are made from FKM.

* Seal kit includes 15, 16, 17 and 19. Order the seal kit based on each bore size.

* Since the seal kit does not include a grease pack, order it separately.

Grease for food part no.: GR-H-010 (10 g)

Standard grease part no.: GR-S-010 (10 g)

⚠ Caution

Please contact SMC to repair or replace seals of cylinder bore size 40 mm and above.

Please contact SMC when the cylinder has to be disassembled for the purpose of replacing seals, etc.