

Series REAH

Single axis type: $\phi 10$, $\phi 15$

Construction

Single axis type: $\phi 10$, $\phi 15$

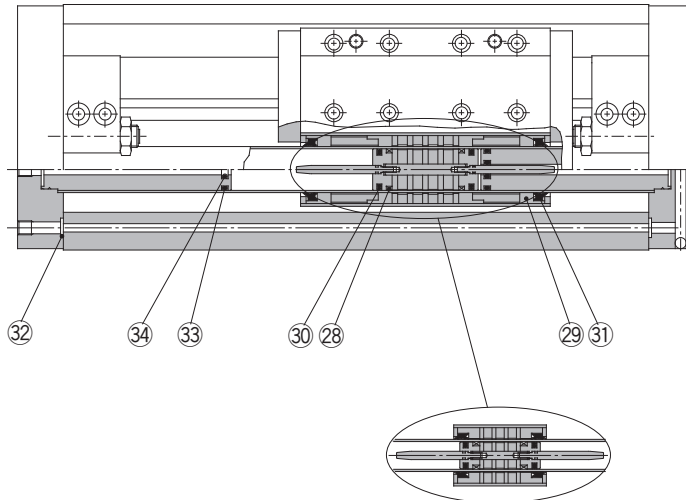

REAH10

* The numbers are the same as the "Construction" of the Best Pneumatics No.3 Series REAH.

Seal Kit List

No.	Description	Material	Note
28	Wear ring A	Special resin	$\phi 10$: Not available
29	Wear ring B	Special resin	
30	Piston seal	NBR	
31	Scraper	NBR	
32	O-ring	NBR	
33	O-ring	NBR	
34	Cushion seal	NBR	

Replacement Parts: Seal Kit

Bore size (mm)	Kit no.	Contents
10	REAH10-PS	Set of left nos. 29, 30, 31, 32, 33, 34
15	REAH15-PS	Set of left nos. 28, 29, 30, 31, 32, 33, 34

Note) Seal kit includes 28 to 34. Order the seal kit, based on each bore size.

Note) It may be difficult to replace the cushion seal 34.

Note) For wear ring A of $\phi 10$, please consult with SMC.

* Seal kit includes a grease pack ($\phi 10$: 5 g and 10 g, $\phi 15$: 10 g).

Order with the following part number when only the grease pack is needed.

For $\phi 10$ grease pack part no.: GR-F-005 (5 g) for external sliding part
GR-S-010 (10 g) for tube interior

For $\phi 15$ grease pack part no.: GR-S-010 (10 g)

Series REAH

Single axis type: $\varnothing 20$, $\varnothing 25$

Construction

Single axis type: $\varnothing 20$, $\varnothing 25$

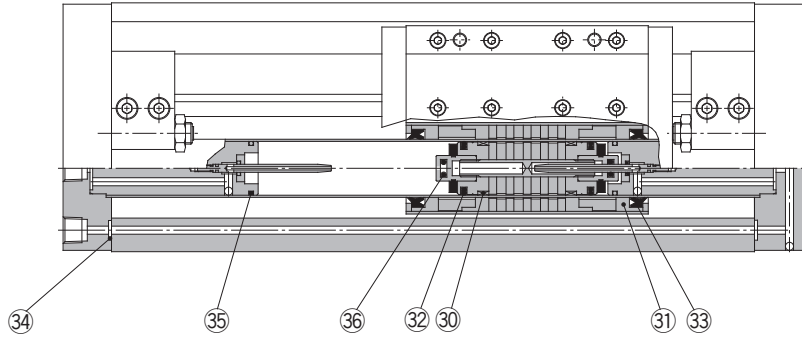

* The numbers are the same as the "Construction" of the Best Pneumatics No.3 Series REAH.

Seal Kit List

No.	Description	Material	Note
30	Wear ring A	Special resin	
31	Wear ring B	Special resin	
32	Piston seal	NBR	
33	Scraper	NBR	
34	O-ring	NBR	
35	O-ring	NBR	
36	Cushion seal	NBR	

Replacement Parts: Seal Kit

Bore size (mm)	Kit no.	Contents
20	REAH20-PS	Set of left nos.
25	REAH25-PS	30, 31, 32, 33, 34, 35, 36

Note) Seal kit includes 30 to 36. Order the seal kit, based on each bore size.

Note) It may be difficult to replace the cushion seal 36.

* Seal kit includes a grease pack (10 g).

Order with the following part number when only the grease pack is needed.

Grease pack part no.: GR-S-010 (10 g)

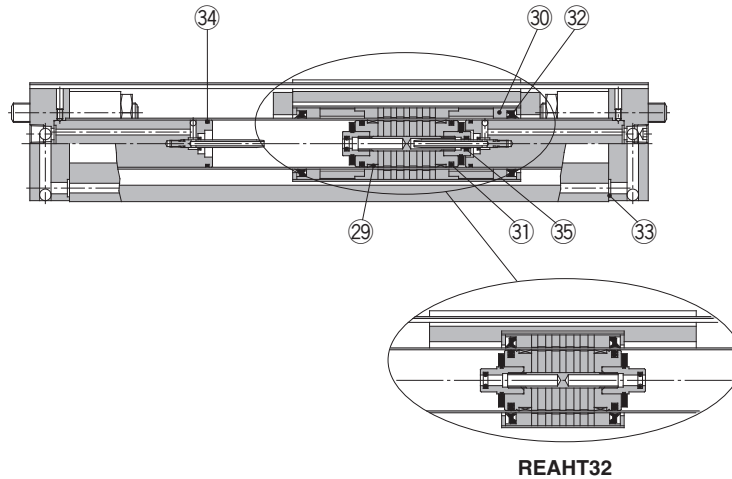
Series REAHDouble axis type: $\phi 25$, $\phi 32$ **Construction**Double axis type: $\phi 25$, $\phi 32$ 

* The numbers are the same as the "Construction" of the Best Pneumatics No.3 Series REAH.

Seal Kit List

No.	Description	Material	Note
29	Wear ring A	Special resin	
30	Wear ring B	Special resin	
31	Piston seal	NBR	
32	Scraper	NBR	
33	O-ring	NBR	
34	O-ring	NBR	
35	Cushion seal	NBR	

Replacement Parts: Seal Kit

Bore size (mm)	Kit no.	Contents
25	REAHT25-PS	Set of left nos. 29, 30, 31, 32, 33, 34, 35
32	REAHT32-PS	

Note) Seal kit includes 29 to 35. Order the seal kit, based on each bore size.

Note) It may be difficult to replace the cushion seal 35.

* Seal kit includes a grease pack (10 g).

Order with the following part number when only the grease pack is needed.

Grease pack part no.: GR-S-010 (10 g)