

Series RHC

ø20, ø25, ø32, ø40
ø50, ø63, ø80, ø100

Replacement
Procedure is
P.364

Construction

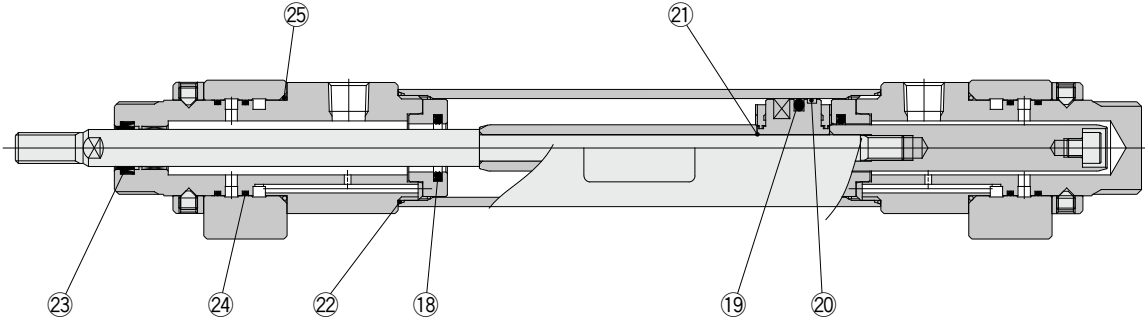

* The numbers are the same as the "Construction" of the Best Pneumatics No.3 Series RHC.

Seal Kit List

No.	Description	Material	Qty.	Note
18	Cushion seal	Special resin	2	21 is a non-replaceable part, so it is not included in the seal kit.
19	Piston seal	NBR	1	
20	Wear ring	Resin	1	
21	Piston gasket	NBR	—	
22	Cylinder tube gasket	NBR	2	
23	Rod seal	NBR	1	
24	O-ring	NBR	4	
25	O-ring	NBR	2	

Replacement Parts: Seal Kit

Bore size (mm)	Kit no.	Contents
20	RHC20-PS	Set of left nos. 18, 19, 20, 22, 23, 24, 25
25	RHC25-PS	
32	RHC32-PS	
40	RHC40-PS	

* Seal kit includes a grease pack (10 g).
Order with the following part number when only the grease pack is needed.

Grease pack part no.: GR-S-010 (10 g)

⚠ Caution

When disassembling cylinders with bore sizes of ø20 through ø40, grip the double flat part of either the rod cover or the head cover with a vise and loosen the other side with a wrench or an adjustable angle wrench, and then remove the cover. When retightening, tighten approximately 2 degrees more than the original position.