

# Valve Mounted Cylinder/Double Acting

# Series CV3

Lube, Non-lube type:  
 ø40, ø50, ø63, ø80, ø100

## Construction

### Lube type

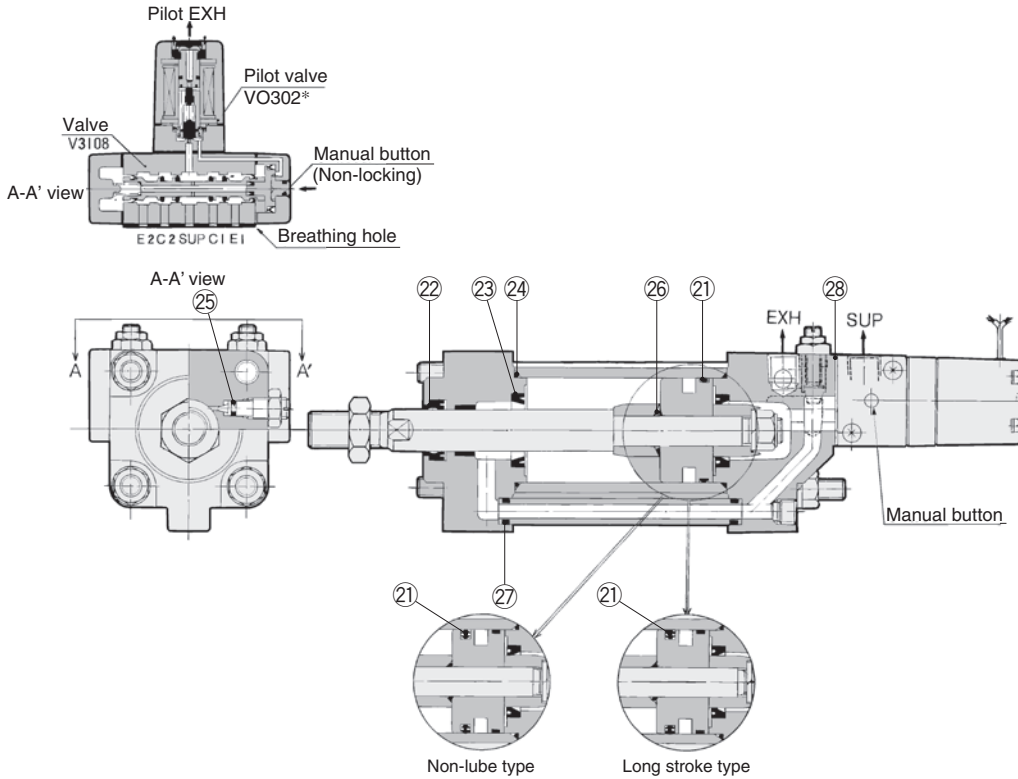

\* The numbers are the same as the "Construction" of the Best Pneumatics No.3 Series CV3.

### Seal Kit List

No.	Description	Material	Note
21	Piston seal	NBR	23 and 26 are non-replaceable parts, so they are not included in the seal kit.
22	Rod seal		
23	Cushion seal		
24	Cylinder tube gasket		
25	Cushion valve seal		
26	Piston gasket		
27	Pipe gasket		
28	Head cover gasket		

### Replacement Parts: Seal Kit

Bore size (mm)	Kit no.	Contents
<b>Lube type</b>		
40	CV3-40-PS	Set of left nos. 21, 22, 24, 25, 27, 28
50	CV3-50-PS	
63	CV3-63-PS	
80	CV3-80-PS	
100	CV3-100-PS	
<b>Non-lube type</b>		
40	CV3N40-PS	Set of left nos. 21, 22, 24, 25, 27, 28
50	CV3N50-PS	
63	CV3N63-PS	
80	CV3N80-PS	
100	CV3N100-PS	

\* Seal kit includes 21, 22, 24, 25, 27, 28. Order the seal kit, based on each bore size.

\* Seal kit includes a grease pack (ø40, ø50: 10 g, ø63, ø80: 20 g, ø100: 30 g).

Order with the following part number when only the grease pack is needed.

Grease pack part no.: GR-S-010 (10 g), GR-S-020 (20 g)

Actuators

Modular F.R.L.  
Pressure Control Equipment

Air Preparation Equipment

Industrial Filters

Replacement Procedure

Actuators

Modular F.R.L.  
Pressure Control Equipment

Industrial Filters