

# Series CA2W

ø40, ø50, ø63  
ø80, ø100

Replacement  
Procedure is  
P.284

## Construction

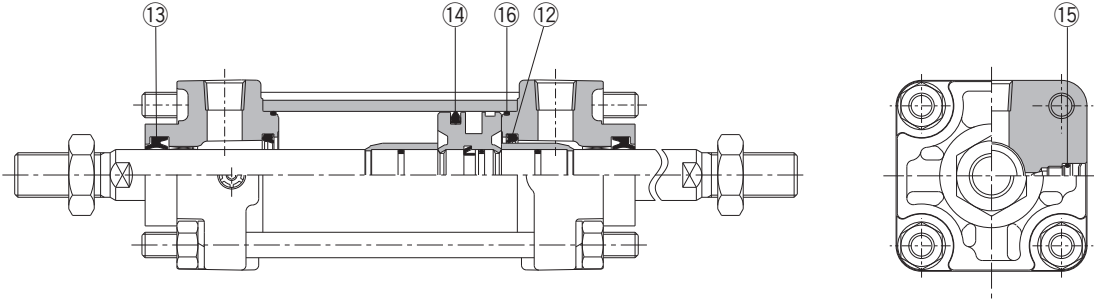

\* The numbers are the same as the "Construction" of the Best Pneumatics No.2 Series CA2W.

### Seal Kit List

No.	Description	Material	Note
12	Cushion seal	Urethane	
13	Rod seal	NBR	
14	Piston seal	NBR	
15	Cushion valve seal	NBR	O-ring
16	Cylinder tube gasket	NBR	

15 is a non-replaceable part, so it is not included in the seal kit.

### Replacement Parts: Seal Kit

Bore size (mm)	Kit no.	Contents
40	MBW40-PS	Set of left nos. 12, 13, 14, 16.
50	MBW50-PS	
63	MBW63-PS	
80	MBW80-PS	
100	MBW100-PS	

\* Do not disassemble the trunnion style.

\* Seal kit includes 12, 13, 14 and 16. Order the seal kit based on each bore size.

\* Seal kit includes a grease pack (ø40, 50: 10 g, ø63, 80: 20 g, ø100: 30 g).

Order with the following part number when only the grease pack is needed.

**Grease pack part no.:** GR-S-010 (10 g), GR-S-020 (20 g)