

# JIS Standard Hydraulic Cylinder/Double Acting, Double Rod

## Series CH2EW/CH2FW

ø32, ø40  
ø50, ø63  
ø80, ø100

Replacement  
Procedure is  
P.396

### Construction

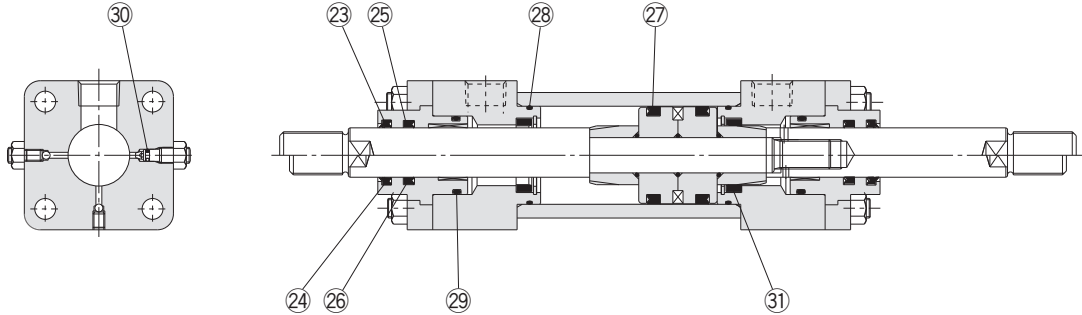

\* The numbers are the same as the "Construction" of the Best Pneumatics No.8 Series CH2EW/CH2FW.

#### Seal Kit List

No.	Description	Material	Note
23	Scraper (B-series rod)	NBR	
24	Scraper (C-series rod)	NBR	
25	Rod seal (B-series rod)	NBR	
26	Rod seal (C-series rod)	NBR	
27	Piston seal	NBR	
28	Cylinder tube gasket	NBR	
29	Holder gasket	NBR	
30	Cushion valve seal	NBR	
31	Cushion seal	—	

#### Replacement Parts: Seal Kit

Bore size (mm)	Seal kit no.		Content
	B-series rod	C-series rod	
40	CH2EW40B-PS	CH2EW40C-PS	B-series rod: Set of left nos. 23, 25, 27, 28, 29, 30, 31
	CH2FW40B-PS	CH2FW40C-PS	
50	CH2EW50B-PS	CH2EW50C-PS	C-series rod: Set of left nos. 24, 26, 27, 28, 29, 30, 31
	CH2FW50B-PS	CH2FW50C-PS	
63	CH2EW63B-PS	CH2EW63C-PS	
	CH2FW63B-PS	CH2FW63C-PS	
80	CH2EW80B-PS	CH2EW80C-PS	
	CH2FW80B-PS	CH2FW80C-PS	
100	CH2EW100B-PS	CH2EW100C-PS	
	CH2FW100B-PS	CH2FW100C-PS	

\* Seal kit consists of items 23 through 31 and can be ordered using the seal kit number for each bore size.

Actuators

Modular F.R.L.  
Pressure Control Equipment

Air Preparation  
Equipment

Industrial Filters

Replacement  
Procedure

Actuators

Modular F.R.L.  
Pressure Control Equipment

Industrial Filters