

JIS Standard Hydraulic Cylinder/Double Acting, Single Rod

Series CH2E/CH2F/CH2G/CH2H

ø32, ø40
ø50, ø63
ø80, ø100

Replacement
Procedure is
P.396

Construction

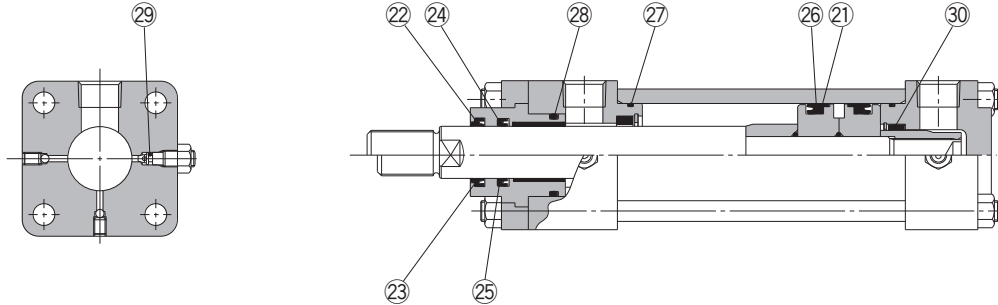

* The numbers are the same as the "Construction" of the Best Pneumatics No.8 Series CH2E/CH2F/CH2G/CH2H.

Seal Kit List

No.	Description	Material	Note
①	Back-up ring	Resin	
②	Scraper (B-series rod)	NBR	
③	Scraper (C-series rod)	NBR	
④	Rod seal (B-series rod)	NBR	
⑤	Rod seal (C-series rod)	NBR	
⑥	Piston seal	NBR	
⑦	Cylinder tube gasket	NBR	
⑧	Holder gasket	NBR	
⑨	Cushion valve seal	NBR	
⑩	Cushion seal	—	

Replacement Parts: Seal Kit

Bore size (mm)	Seal kit no.		Content
	B-series rod	C-series rod	
32	CH2E32B-PS	/	
	CH2F32B-PS		
	CH2G32B-PS		
	CH2H32B-PS		
40	CH2E40B-PS	CH2E40C-PS	
	CH2F40B-PS	CH2F40C-PS	
	CH2G40B-PS	CH2G40C-PS	
	CH2H40B-PS	CH2H40C-PS	
50	CH2E50B-PS	CH2E50C-PS	B-series rod: Set of left nos. ①, ②, ④, ⑥, ⑦, ⑧, ⑨, ⑩
	CH2F50B-PS	CH2F50C-PS	
	CH2G50B-PS	CH2G50C-PS	
	CH2H50B-PS	CH2H50C-PS	
63	CH2E63B-PS	CH2E63C-PS	C-series rod: Set of left nos. ①, ③, ⑤, ⑥, ⑦, ⑧, ⑨, ⑩
	CH2F63B-PS	CH2F63C-PS	
	CH2G63B-PS	CH2G63C-PS	
	CH2H63B-PS	CH2H63C-PS	
80	CH2E80B-PS	CH2E80C-PS	
	CH2F80B-PS	CH2F80C-PS	
	CH2G80B-PS	CH2G80C-PS	
	CH2H80B-PS	CH2H80C-PS	
100	CH2E100B-PS	CH2E100C-PS	
	CH2F100B-PS	CH2F100C-PS	
	CH2G100B-PS	CH2G100C-PS	
	CH2H100B-PS	CH2H100C-PS	

* Seal kit consists of items ① through ⑩ and can be ordered by using the seal kit number for each bore size.