

Series MY1C

ø16, ø20, ø25, ø32
ø40, ø50, ø63

Replacement
Procedure is
P.306

Construction

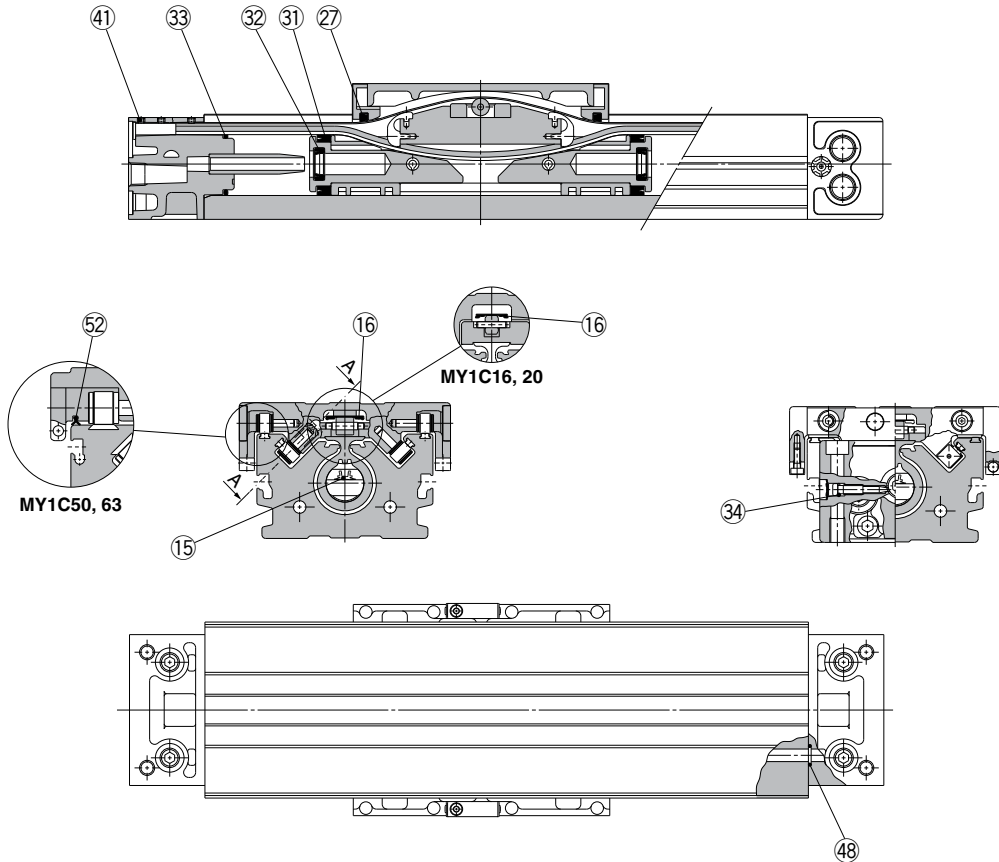

* The numbers are the same as the "Construction" of the Best Pneumatics No.2 Series MY1C.

*[BLUE](#) links will lead to purchase pages.

Call or email us at sales@smcpneumatics.com for request.

Seal Kit List (15, 16, 34 and 52 are not included in the seal kit. Order them as required with by individual part numbers.)

No.	Description	Qty.	MY1C16	MY1C20	MY1C25	MY1C32	MY1C40	MY1C50	MY1C63
15	Seal belt	1	MY16-16A-Stroke	MY20-16A-Stroke	MY25-16A-Stroke	MY32-16A-Stroke	MY40-16A-Stroke	MY50-16A-Stroke	MY63-16A-Stroke
16	Dust seal band	1	MY16-16B-Stroke	MY20-16B-Stroke	MY25-16B-Stroke	MY32-16B-Stroke	MY40-16B-Stroke	MY50-16B-Stroke	MY63-16B-Stroke
34	O-ring	2	KA00309 (ø4 x ø1.8 x ø1.1)	KA00311 (ø5.1 x ø3 x ø1.05)	KA00311 (ø5.1 x ø3 x ø1.05)	KA00320 (ø7.15 x ø3.75 x ø1.7)	KA00402 (ø8.3 x ø4.5 x ø1.9)	KA00777	KA00777
52	Side scraper	2	—	—	—	—	—	MYM50-15CK0502B	MYM63-15CK0503B
27	Scraper	2							
31	Piston seal	2							
32	Cushion seal	2	MY1M16-PS	MY1M20-PS	MY1M25-PS	MY1M32-PS	MY1M40-PS	MY1M50-PS	MY1M63-PS
33	Tube gasket	2							
48	O-ring	4							

* Seal kit includes 27, 31, 32, 33 and 48. Order the seal kit based on each bore size.

* Seal kit includes a grease pack (10 g).

When 15 and 16 are shipped independently, a grease pack is included. (10 g per 1000 strokes)

Order with the following part number when only the grease pack is needed.

Grease pack part no.: GR-S-010 (10 g), GR-S-020 (20 g)

Note) Two kinds of dust seal bands are available. Verify the type to use, since the part number varies depending on the treatment of the hexagon socket head set screw 41.

A: Black zinc chromated → MY□□-16B-stroke, B: Nickel plated → MY□□-16BW-stroke