



135 SERIES

MODELS

135ADC56/12

135ADC56/24

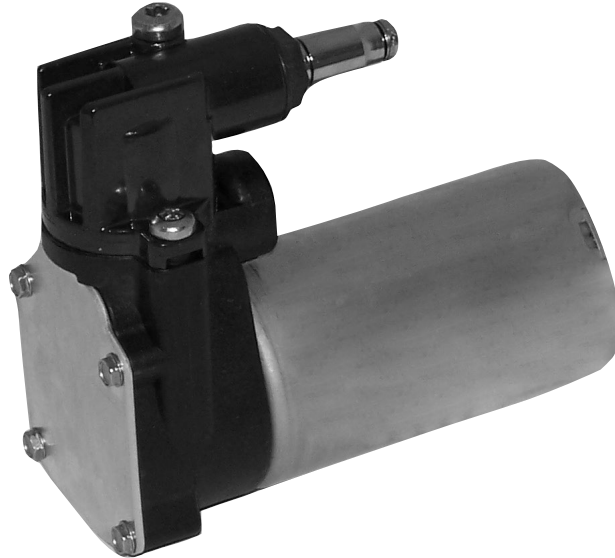

FEATURES

- Oil-less, non-lube piston and cylinder
- Stainless steel and silicone valves
- Lightweight plastic and die-cast zinc-aluminum alloy components
- Balanced for smooth, low vibration operation
- Long-life, high performance PTFE compound piston ring
- Built-in inlet filter
- Dust and moisture resistant
- Permanently lubricated motor shaft and connecting rod bearings
- RoHS compliant (Green, eco-friendly)

Consult factory for custom applications

Thomas Division is an ISO 9001 registered company

THOMAS
A Gardner Denver Product

USAThomas.com

(800) 799-4568 | 3810 Prospect Ave, Ste. A, Yorba Linda, CA 92886

135 Series Performance Data

MODEL NUMBER		135ADC56/12		135ADC56/24	
HEAD CONFIGURATION		Pressure Only		Pressure Only	
STROKE		.56 inches		.56 inches	
PRESSURE		Flow @ 12V DC		Flow @ 24V DC	
cfm @ psi	lpm @ bar				
psi	bar	cfm	lpm	cfm	lpm
0	0	.54	15.3	.54	15.3
10	.5	.48	14.2	.48	14.2
20	1.0	.42	12.7	.42	12.7
30	1.5	.38	11.6	.38	11.6
40	2.0	.33	10.6	.33	10.6
50	3.0	.30	9.1	.30	9.1
60	5.0	.27	6.8	.27	6.8
70	7.0	.24	4.8	.24	4.8
80		.22		.22	
90		.19		.19	
100		.17		.17	
MAX. CONTINUOUS PRESSURE		-	-	-	-
MAX. INTERMITTENT PRESSURE		87 psi	6.0 bar	87 psi	6.0 bar
MAX. DUTY CYCLE (MINUTES ON/OFF AT 23°C)		1 min. on / 20 min. off		1 min. on / 20 min. off	
MAX. AMBIENT AIR TEMP.		+149°F	+65°C	+149°F	+65°C
MIN. AMBIENT START TEMP.		-22°F	-30°C	-22°F	-30°C
MAX. RESTART PRESSURE		100 psi	8.3 bar	120 psi	8.3 bar
MOTOR VOLTAGE		12V DC		24V DC	
MOTOR TYPE		Permanent Magnet		Permanent Magnet	
CURRENT AT RATED LOAD (AMPS)		7.9		3.8	
POWER AT RATED LOAD (WATTS)		95		92	
IN-RUSH CURRENT (LOCKED ROTOR, AMPS)		29.0		17.0	
CAPACITOR VALUE		-		-	
MIN. FULL LOAD SPEED (RPM)		3915		4480	
THERMAL PROTECTOR		-		-	
NET WEIGHT		1.16 lb	.53 kg	1.16 lb	.53 kg

135ADC

Millimeters are in []

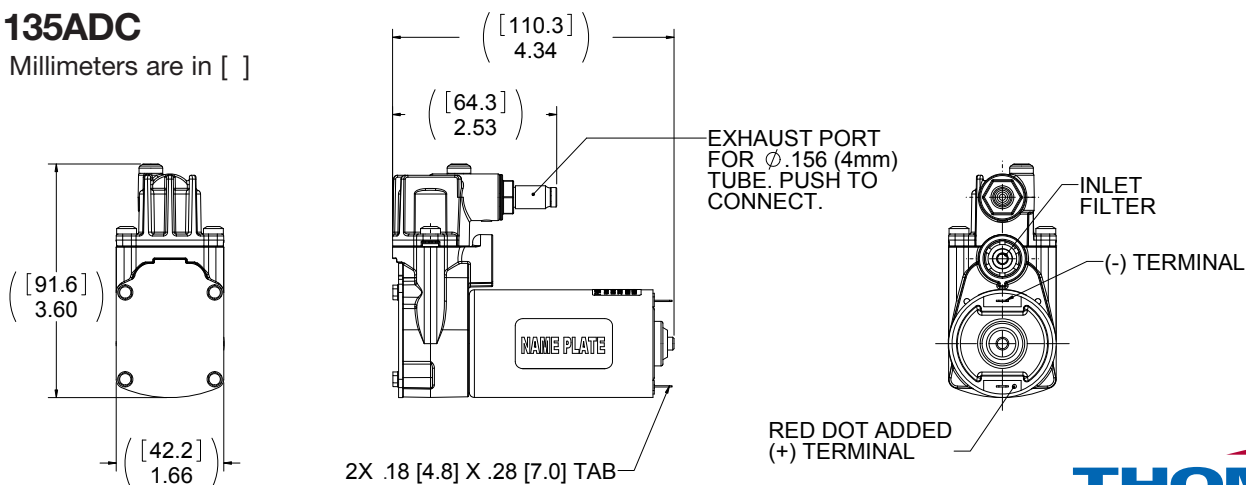

The information presented in this material is based on technical data and test results of nominal units. It is believed to be accurate and reliable and is offered as an aid to help in the selection of Thomas products. It is the responsibility of the user to determine the suitability of the product for his intended use and the user assumes all risk and liability whatsoever in connection therewith. Thomas Industries does not warrant, guarantee or assume any obligation or liability in connection with this information.

NOTE: Models pictured are representative of the series and do not represent a specific model number. Consult factory for detailed physical description.