

**Air Saving Valve
Pressure Valve**

Flow Valve

Series ASR/Series ASQ

**40% reduction in
air consumption**

Cuts air consumption by
operating the return stroke
at a reduced pressure.

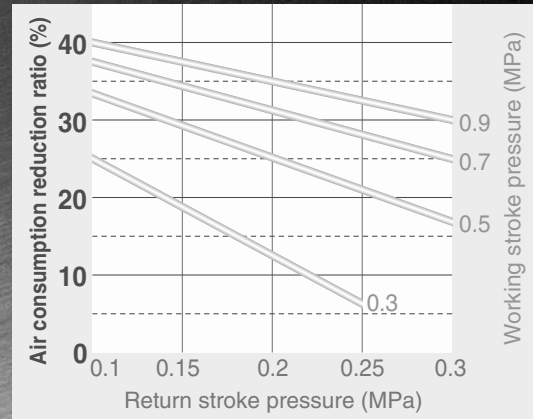

- AS
- ASP
- ASN
- AQ
- ASV
- AK
- ASS
- ASR**
- ASF

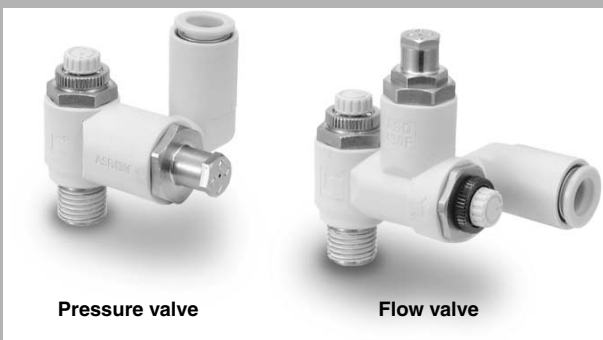

Pressure valve

Flow valve

Cuts air consumption by operating the return stroke at a reduced pressure.

Conventional valve

Working and return strokes operated at the same pressure

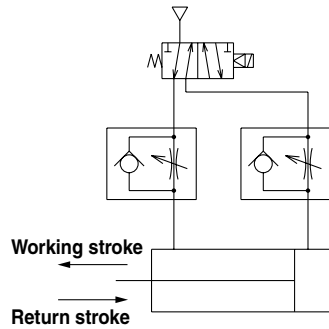

Air saving valve

Return stroke operated at a reduced pressure

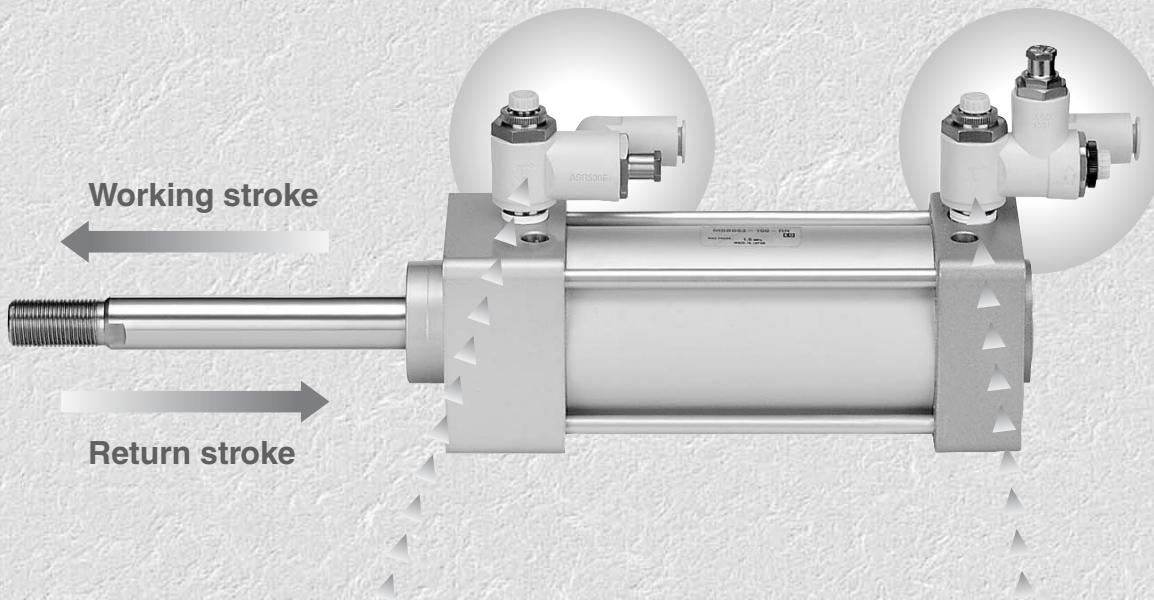
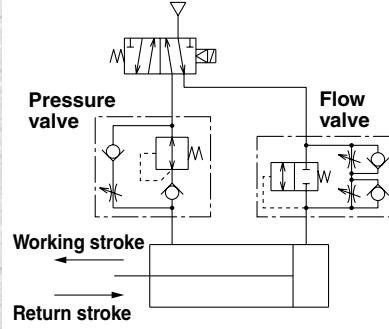

Pressure valve

Regulator with check valve
+
Speed controller



Series ASR

Flow valve

Quick supply and exhaust valve
+
Speed controller
(Meter-in, Meter-out)

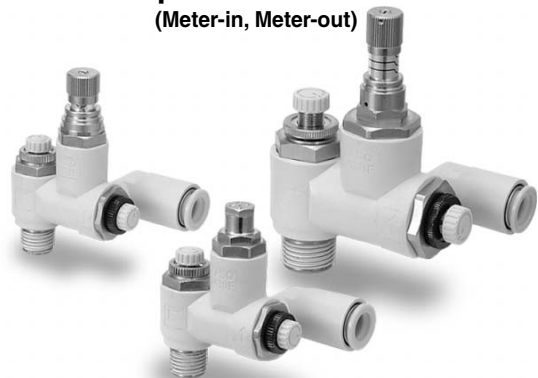

Series ASQ

Smooth operation of working and return strokes possible.

Consistent speed control achieved by preventing jerky movement of working strokes.

Improved response time

Operation delay in a return stroke is reduced by the use of a quick supply and exhaust valve.

Delay in return operation

- Cylinder operation by conventional 2 pressure control
- Cylinder operation by air saving valve
- - - Cylinder operation by speed controller

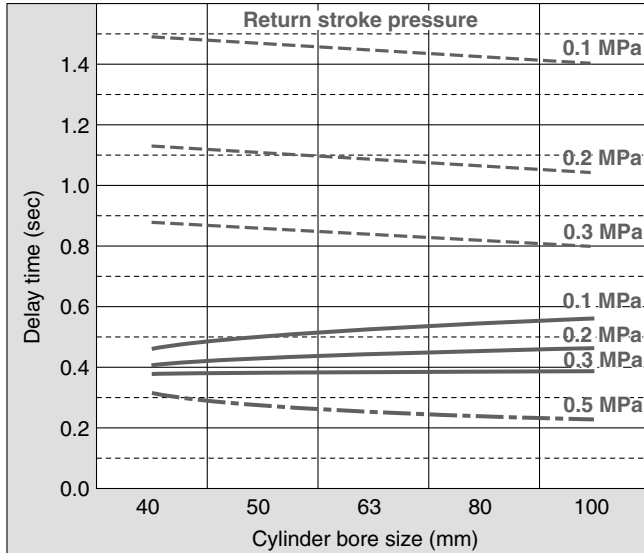

Cylinder speed: 200 mm/sec
Cylinder stroke: 200 mm

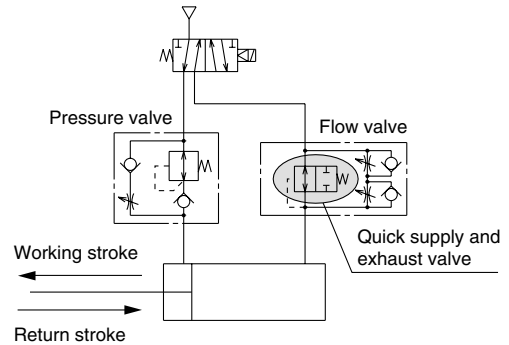

Cylinder operating pressure (MPa)	Air consumption reduction ratio (%)	
	Working stroke	Return stroke
0.5		0.5
		0.3
		0.2
		0.1

Easy piping

The body and one-touch fitting allow 360° rotation. The sealant on the male thread is standardized.

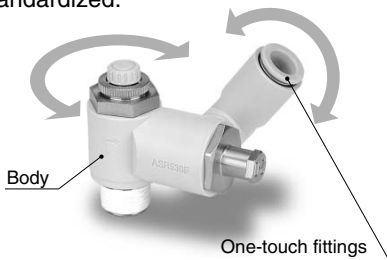

The set pressure can be either fixed or variable.

Fixed set pressure type (Fixed at 0.2 MPa) **Variable set pressure type** (Variable between 0.1 and 0.3 MPa) **Graduated knob**



A knob cap is attached to the variable set pressure type.

Other applications

Jerk prevention in vertical operation of the cylinder

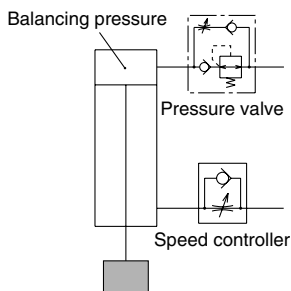

Quick air charge at the end of stroke for press applications

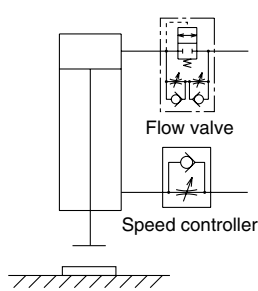

Series Variations

Model		Port size	Applicable tubing O.D. (mm)			
Pressure valve	Flow valve		6	8	10	12
ASR430F-02	ASQ430F-02	R1/4	●	●	●	
ASR530F-02	ASQ530F-02	R1/4	●	●	●	●
ASR530F-03	ASQ530F-03	R3/8	●	●	●	●
ASR630F-03	ASQ630F-03	R3/8			●	●
ASR630F-04	ASQ630F-04	R1/2			●	●

Air Saving Valve Pressure Valve

Flow Valve

Series ASR/Series ASQ

Pressure valve: Series ASR



Regulator with check valve and flow control valve integrated into a single construction

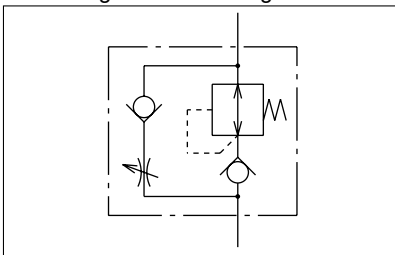

Flow valve: Series ASQ



Pilot valve and two-way flow control valve integrated into a single construction

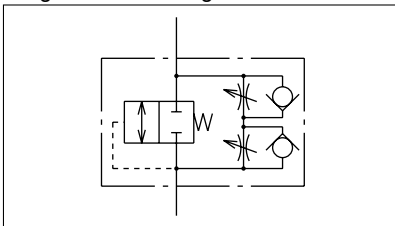

How to Order

ASR 4 3 0 F - 02 - 06 S - F20

- Model**
 - ASR Pressure valve
 - ASQ Flow valve
- Body size**
 - 4 1/4 standard
 - 5 3/8 standard
 - 6 1/2 standard
- Type**
 - 3 Universal

With One-touch fitting
- With seal**
 - Option
 - Nil Variable set pressure type (0.1 to 0.3 MPa)
 - F20 Fixed set pressure type (0.2 MPa)
- Applicable tubing O.D.**
 - 06 6 mm
 - 08 8 mm
 - 10 10 mm
 - 12 12 mm
- Port size**
 - 02 R1/4
 - 03 R3/8
 - 04 R1/2

Model

Model		Port size	Applicable tubing O.D. (mm)			
Pressure valve	Flow valve		6	8	10	12
ASR430F-02	ASQ430F-02	R1/4	●	●	●	
ASR530F-02	ASQ530F-02	R1/4	●	●	●	●
ASR530F-03	ASQ530F-03	R3/8	●	●	●	●
ASR630F-03	ASQ630F-03	R3/8			●	●
ASR630F-04	ASQ630F-04	R1/2			●	●

Specifications

Proof pressure	1.5 MPa	
Maximum operating pressure	1.0 MPa	
Set pressure range	Variable	0.1 to 0.3 MPa
	Fixed (option)	0.2 MPa
Ambient and fluid temperature	-5 to 60°C (with no freezing)	
Number of needle rotations	10 rotations	
Applicable tubing material	Nylon, Soft nylon, Polyurethane	

Effective Area

Pressure Valve: Series ASR

Type	Free flow mm ²	Controlled flow mm ²
ASR430F-02-06S(-F20)	5.4	5.9
ASR430F-02-08S(-F20)	5.9	6.7
ASR430F-02-10S(-F20)	5.9	6.7
ASR530F-02-06S(-F20)	7.3	8.1
ASR530F-02-08S(-F20)	8.9	11.8
ASR530F-02-10S(-F20)	9.2	13.3
ASR530F-02-12S(-F20)	9.5	13.7
ASR530F-03-06S(-F20)	7.3	8.1
ASR530F-03-08S(-F20)	8.9	11.8
ASR530F-03-10S(-F20)	9.2	13.3
ASR530F-03-12S(-F20)	9.5	13.7
ASR630F-03-10S(-F20)	15.3	17.8
ASR630F-03-12S(-F20)	16.0	19.1
ASR630F-04-10S(-F20)	15.3	17.8
ASR630F-04-12S(-F20)	16.0	19.1

Flow Valve: Series ASQ

Type	Meter-out mm ²	Meter-in mm ²
ASQ430F-02-06S(-F20)	4.1	4.9
ASQ430F-02-08S(-F20)	4.6	5.5
ASQ430F-02-10S(-F20)	4.6	5.5
ASQ530F-02-06S(-F20)	6.6	7.8
ASQ530F-02-08S(-F20)	9.2	10.1
ASQ530F-02-10S(-F20)	9.8	10.8
ASQ530F-02-12S(-F20)	10.8	11.6
ASQ530F-03-06S(-F20)	6.6	7.8
ASQ530F-03-08S(-F20)	9.2	10.1
ASQ530F-03-10S(-F20)	9.8	10.8
ASQ530F-03-12S(-F20)	10.8	11.6
ASQ630F-03-10S(-F20)	15.3	17.1
ASQ630F-03-12S(-F20)	16.2	18.0
ASQ630F-04-10S(-F20)	15.3	17.1
ASQ630F-04-12S(-F20)	16.2	18.0

Operating Principle

Working Stroke

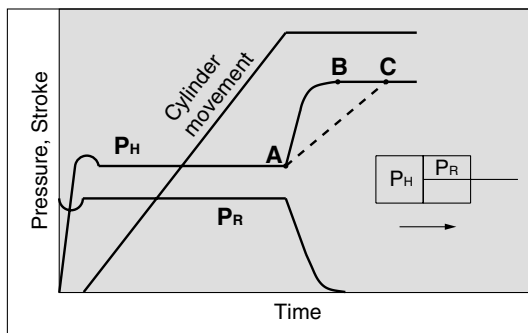

1. The cylinder starts smoothly because jerks are prevented by meter-in control.

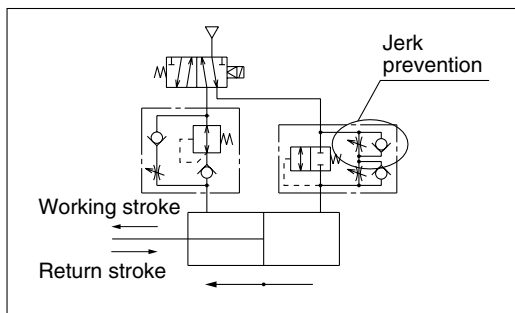

2. When the cylinder reaches the stroke end, the quick air charge by the flow valve rapidly increases the rear side pressure (PH) from A to B. If a speed controller is used instead of the flow valve, charging air will take more time as illustrated by line A-C, causing delay in the pressure rise.

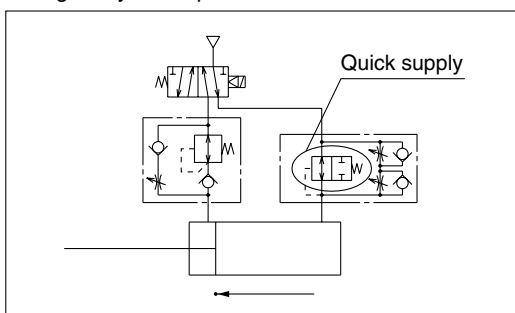

Return Stroke

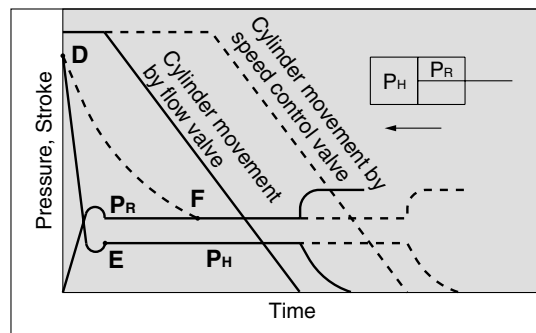

3. To prevent delay due to the pressure gap, air is rapidly exhausted to decrease the pressure from D to E, after which the piston moves at a constant speed. If a speed controller is used instead of the flow valve, exhausting air will take more time as illustrated by line D-F, resulting in longer stop time of the cylinder and a consequent time loss.

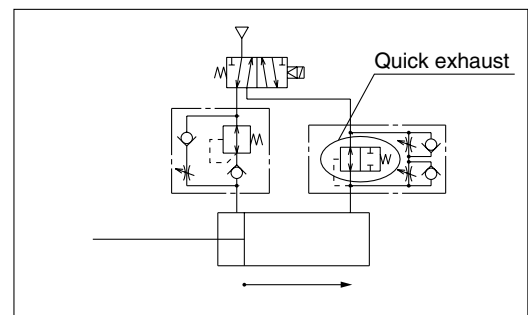

4. The cylinder operates at a low pressure required for a return.

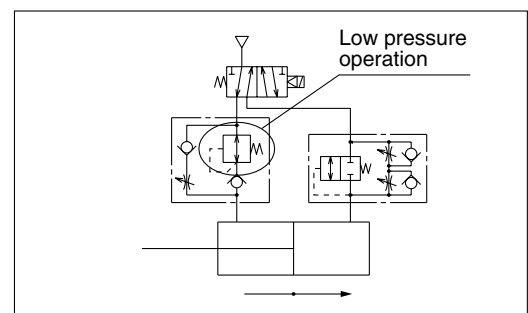

AS
ASP
ASN
AQ
ASV
AK
ASS
ASR
ASF

Series ASR/ASQ

Selection and Adjustment

Install a flow valve on the working side which requires the cylinder output and a pressure valve on the return side. The product cannot be used in cases where the same pressure is necessary for both working and return strokes. In such cases use a speed controller.

Horizontal mounting

Low pressure side: Pressure valve
High pressure side: Flow valve

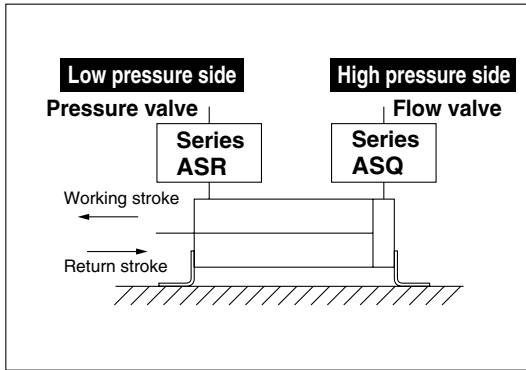

Refer to **Adjustment Procedure 1** for pressure and speed adjustment.

Vertical mounting

Low pressure side: Pressure valve
High pressure side: Flow valve

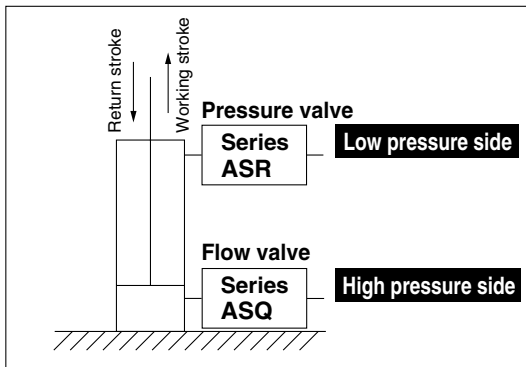

In case the load ratio is 50% or lower at the set pressure of the flow valve:

Refer to **Adjustment Procedure 1** for pressure and speed adjustment.



If the load ratio at the set pressure of the flow valve exceeds 50%, install a dual speed controller (meter-in • Meter-out control) on the high pressure side.

Low pressure side: Pressure valve
High pressure side: Dual speed controller

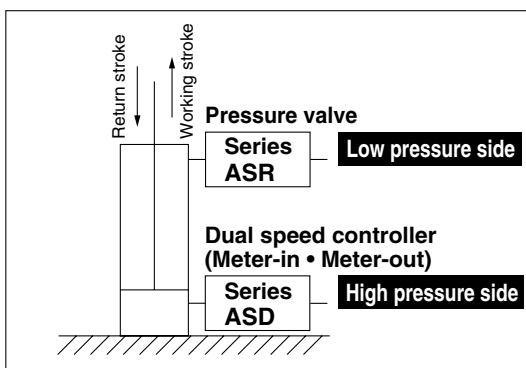

Refer to **Adjustment Procedure 2** for pressure and speed adjustment.

Adjustment Procedure 1

Pressure Adjustment

1. The fixed set pressure type (-F20) does not require adjustment because the pressure is fixed at 0.2 MPa for both the pressure valve and the flow valve.
2. The set pressures of the variable set pressure type pressure valve and flow valve are adjusted with knob (A) and knob (B) respectively. Turn the knob clockwise to increase the pressure and counterclockwise to decrease the pressure.
3. The graduations 1, 2 and 3 correspond to 0.1, 0.2 and 0.3 MPa respectively. Align the bottom end of the knob with the graduated line for adjustment.

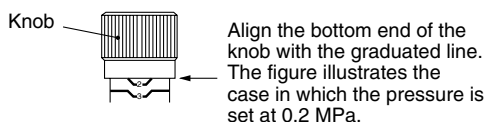

4. Set the same pressure for the pressure valve and the flow valve (0.2 MPa as the recommended value).
5. The inlet side should be supplied with a pressure which is higher than the set pressure by 0.1 MPa or more.
6. Cap the valve after adjustment.

Pressure Valve: Series ASR



Speed Control

1. The cylinder speed is adjusted with knobs (C), (D) and (E). First have all the knobs fully closed and then open them gradually for adjustment. Turn the knob clockwise to close (decrease the speed of the piston rod) and counterclockwise to open (increase the speed of the piston rod).
2. Speed adjustment for the working stroke
The speed is adjusted with the pressure valve and the flow valve.
Open knobs (C) and (E) gradually until the required speed is achieved. Make sure that knobs (C) and (E) are opened by the same number of rotations.
Note 1) If the piston rod jerks, close knob (E) until the smooth operation is achieved.
3. Speed adjustment for return stroke
The speed is adjusted with the flow valve.
Open knob (D) gradually until the required speed is achieved.
4. Be sure to tighten the lock nut after adjustment.

Flow Valve: Series ASQ

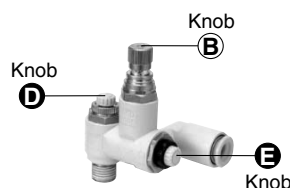

Adjustment Procedure 2

Pressure Adjustment

1. The fixed set pressure type (-F20) does not require adjustment because the pressure is fixed at 0.2 MPa.
2. The pressure at the low pressure side (return stroke side) is adjusted by the pressure valve.
3. The set pressure is adjusted with knob (A). Turn the knob clockwise to increase the pressure and counterclockwise to decrease the pressure.
4. The graduations 1, 2 and 3 correspond to 0.1, 0.2 and 0.3 MPa respectively. Align the bottom end of the knob with the graduated line for adjustment.
5. Keep the set pressure as low as possible in order to achieve good air saving effect.
6. Cap the valve after adjustment.

Pressure Valve: Series ASR



Speed Control

1. The cylinder speed is adjusted with knobs (C), (F) and (G). First have all the knobs fully closed and then open them gradually for adjustment. Turn the knob clockwise to close (decrease the speed of the piston rod) and counterclockwise to open (increase the speed of the piston rod).
2. Speed adjustment for the working stroke
The speed is adjusted with the pressure valve and the dual speed controller.
Open knobs (C) and (G) gradually until the required speed is achieved. Make sure that knobs (C) and (G) are opened by the same number of rotations.
Note 1) If the piston rod jerks, close knob (C) until the smooth operation is achieved.
3. Speed adjustment for return stroke
The speed is adjusted with the dual speed controller.
Open knob (F) gradually until the required speed is achieved.
4. Be sure to tighten the lock nut after adjustment.

Dual Speed Controller: Series ASD



AS
ASP
ASN
AQ
ASV
AK
ASS
ASR
ASF

Series ASR/ASQ

Construction

Pressure Valve: Series ASR

Variable type

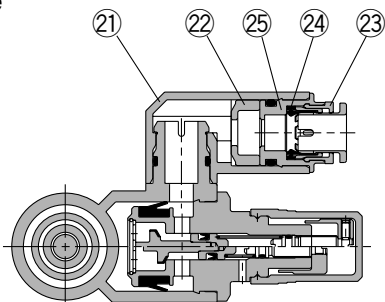

Fixed type

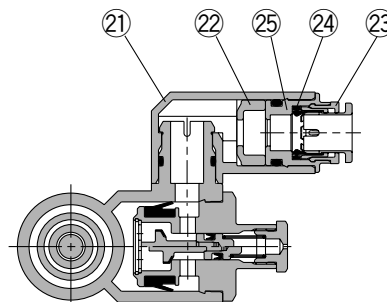

ASR430F-02 type ASR530F-03 type ASR630F-04 type

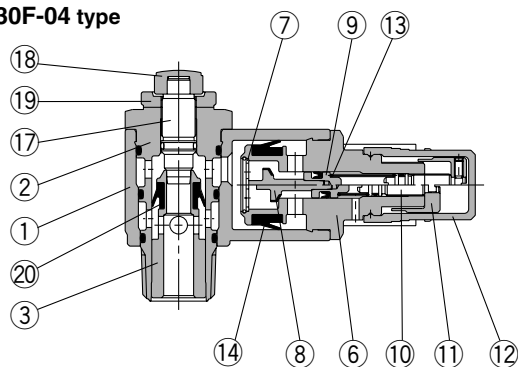

ASR430F-02 type ASR530F-03 type ASR630F-04 type

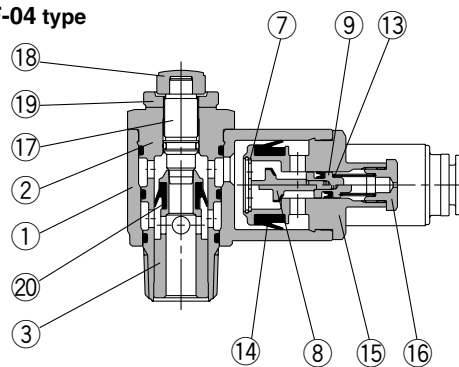

ASR530F-02 type ASR630F-03 type

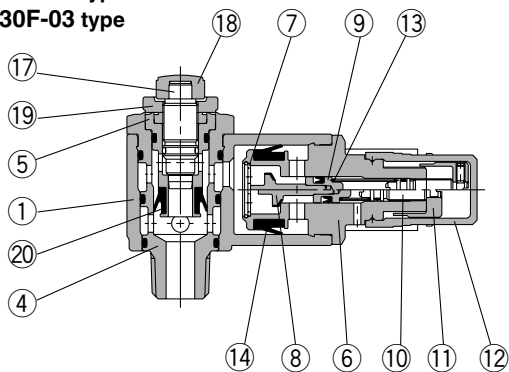

ASR530F-02 type ASR630F-03 type

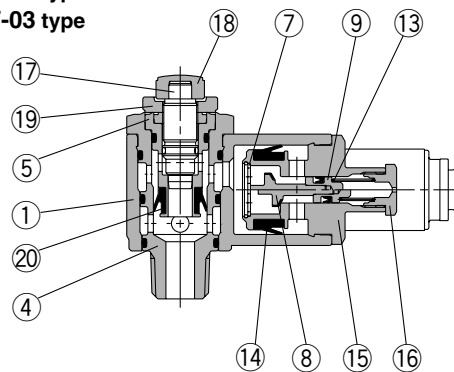

Component Parts

No.	Description	Material	Note
①	Body A	PBT	
②	Body B	Brass	Electroless nickel plated
③	Seat ring	Brass	Electroless nickel plated
④	Body B1	Brass	Electroless nickel plated
⑤	Body B2	Brass	Electroless nickel plated
⑥	Body C	Brass	Electroless nickel plated
⑦	Stopper	Stainless steel	
⑧	Valve	HNBR/Brass	
⑨	Piston	Brass	
⑩	Adjustment screw	Brass	Electroless nickel plated
⑪	Knob	Brass	Electroless nickel plated
⑫	Cap	Polypropylene	
⑬	Adjustment spring	Steel wire	Zinc chromated

No.	Description	Material	Note
⑭	U seal	HNBR	
⑮	Body C	Brass	Electroless nickel plated
⑯	Adjustment plug	Brass	Electroless nickel plated
⑰	Needle	Brass	Electroless nickel plated
⑱	Knob	PBT	
⑲	Lock nut ^{Note 1)}	Steel	Electroless nickel plated
⑳	U seal	HNBR	
㉑	Elbow body	PBT	
㉒	Spacer ^{Note 2)}	PBT	
㉓	Cassette	Stainless steel/POM	
㉔	Seal	NBR	
㉕	Drive body ^{Note 3)}	Brass	Electroless nickel plated

Note 1) Brass is used for the material ASR530F and ASR630F.

Note 2) Not used for ø6 and ø8.

Note 3) Not used for ø10 and ø12.

Flow Valve: Series ASQ

Variable type

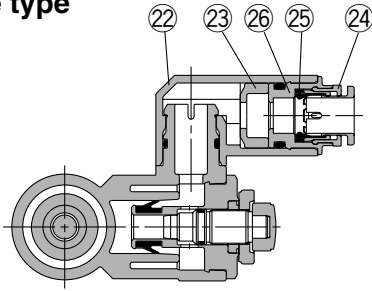

**ASQ430F-02 type
ASQ530F-03 type
ASQ630F-04 type**

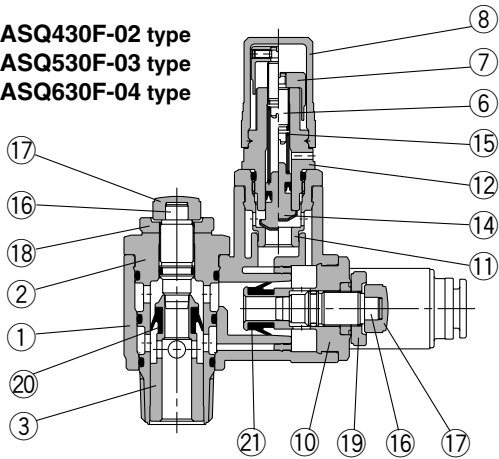

**ASQ530F-02 type
ASQ630F-03 type**

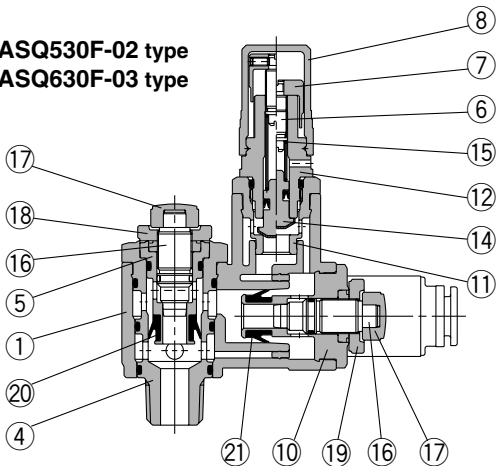

Fixed type

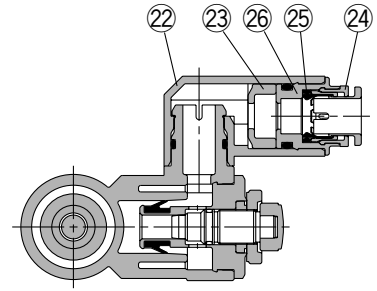

**ASQ430F-02 type
ASQ530F-03 type
ASQ630F-04 type**

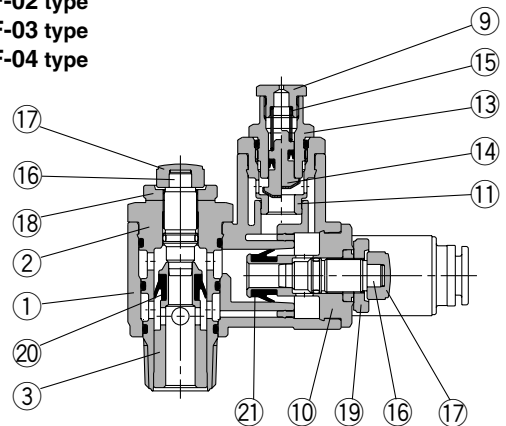

**ASQ530F-02 type
ASQ630F-03 type**

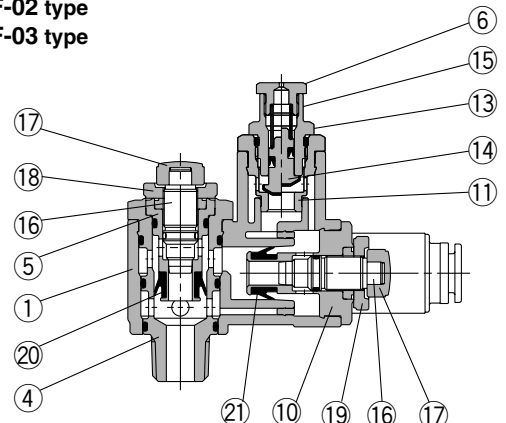

- AS
- ASP
- ASN
- AQ
- ASV
- AK
- ASS
- ASR**
- ASF

Component Parts

No.	Description	Material	Note
①	Body A	PBT	
②	Body B	Brass	Electroless nickel plated
③	Seat ring	Brass	Electroless nickel plated
④	Body B1	Brass	Electroless nickel plated
⑤	Body B2	Brass	Electroless nickel plated
⑥	Adjustment screw	Brass	Electroless nickel plated
⑦	Knob	Brass	Electroless nickel plated
⑧	Cap	Polypropylene	
⑨	Adjustment plug	Brass	Electroless nickel plated
⑩	Body C	Brass	Electroless nickel plated
⑪	Body D1	Brass	Electroless nickel plated
⑫	Body D2	Brass	Electroless nickel plated
⑬	Body D3	Brass	Electroless nickel plated

No.	Description	Material	Note
⑭	Piston valve	HNBR/Brass	
⑮	Adjustment spring	Steel wire	Zinc chromated
⑯	Needle	Brass	Electroless nickel plated
⑰	Knob	PBT	
⑱	Lock nut ^{Note 1)}	Steel	Electroless nickel plated
⑲	Lock nut ^{Note 1)}	Steel	Black zinc chromated
⑳	U seal	HNBR	
㉑	U seal	HNBR	
㉒	Elbow body	PBT	
㉓	Spacer ^{Note 2)}	PBT	
㉔	Cassette	Stainless steel/POM	
㉕	Seal	NBR	
㉖	Drive body ^{Note 3)}	Brass	Electroless nickel plated

Note 1) Brass is used for the material ASQ530F and ASQ630F.
 Note 2) Not used for ø6 and ø8.
 Note 3) Not used for ø10 and ø12.

Series ASR/ASQ

Flow Characteristics

Pressure Valve: Series ASR (Inlet pressure: 0.5 MPa)

ASR430F

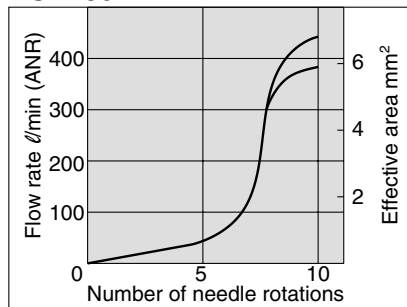

ASR530F

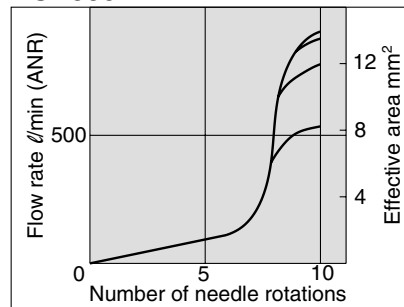

ASR630F

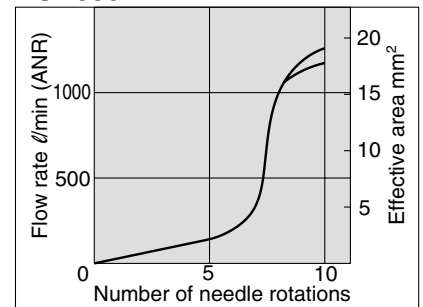

Flow Valve: Series ASQ

Meter-out Type (Inlet pressure: 0.3 MPa)

ASQ430F

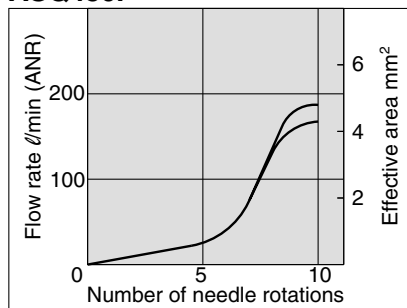

ASQ530F

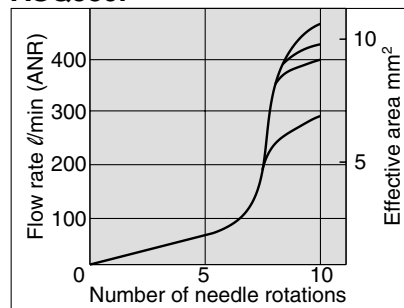

ASQ630F

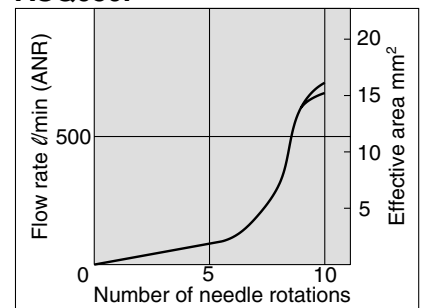

Meter-in Type (Inlet Pressure: 0.5 MPa)

ASQ430F

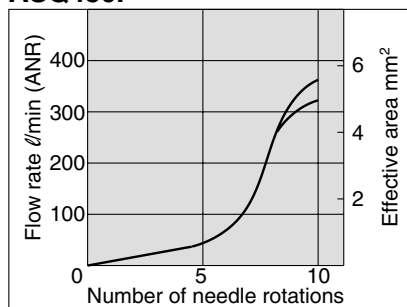

ASQ530F

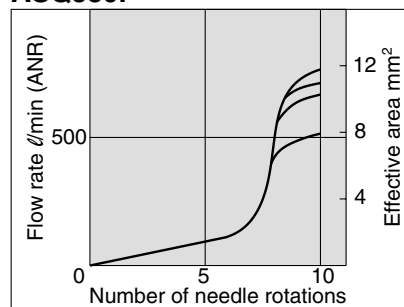

ASQ630F

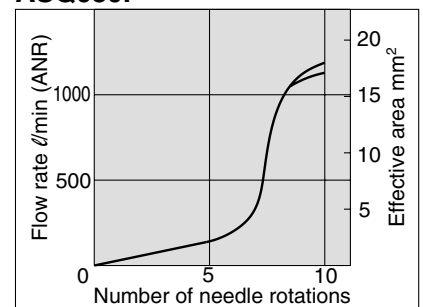

Pressure Characteristics (ASR)

ASR430F, ASR530F

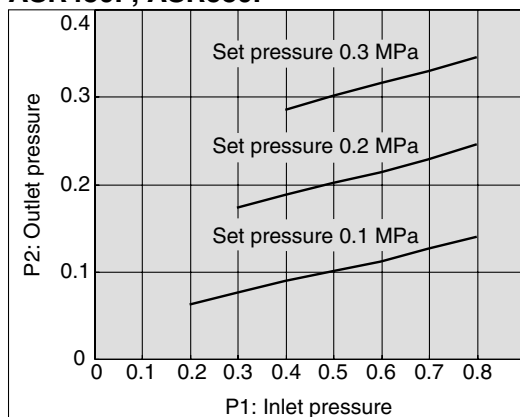

ASR630F

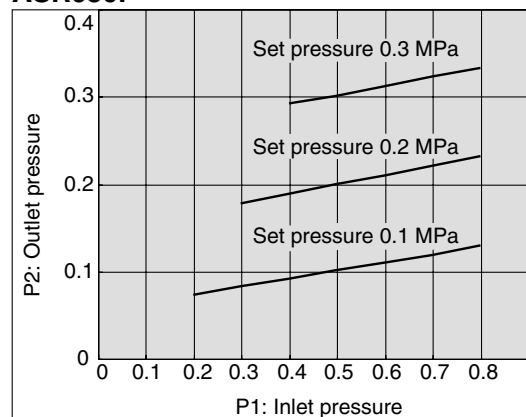

Air Saving Valve Pressure Valve/Flow Valve **Series ASR/ASQ**

Dimensions

Pressure Valve: Series ASR

Variable set pressure type

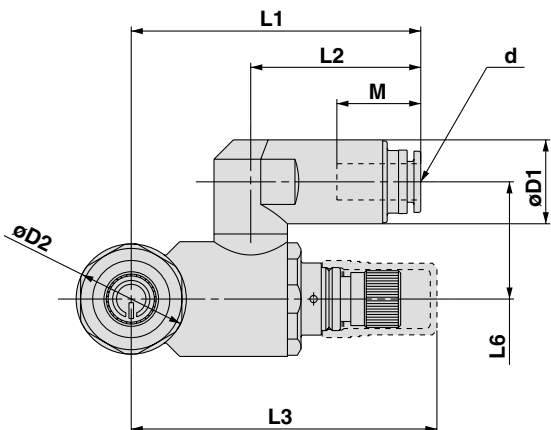

Fixed set pressure type (-F20)

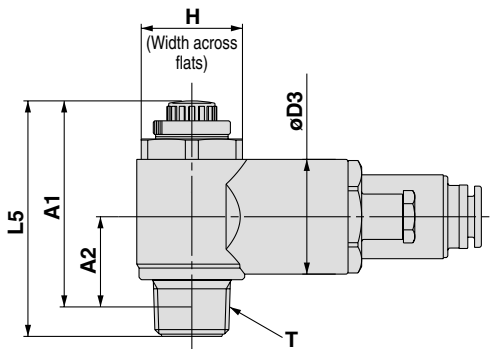
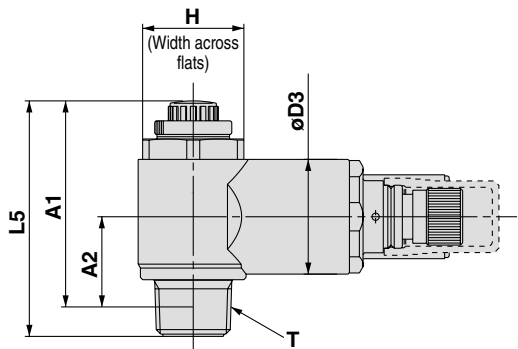
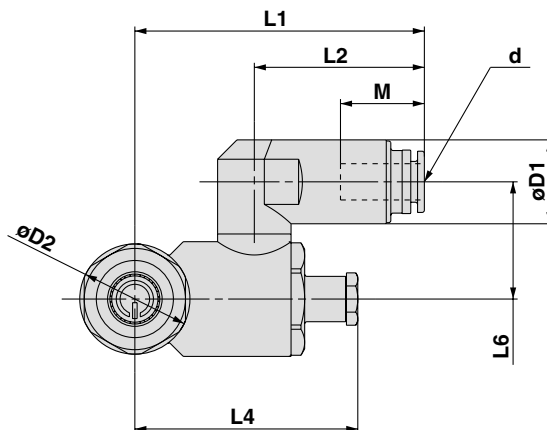

- AS
- ASP
- ASN
- AQ
- ASV
- AK
- ASS
- ASR**
- ASF

Model	Note 1) d	T	H	D1	D2	D3	L1	L2	Note 2) L3	Note 3) L4	L5		L6	A1		A2	M	Weight (g) Note 5)	
											MAX.	MIN.		MAX.	MIN.			*1	*2
ASR430F-02-06S,-F20	6	R1/4	17	18.5	20	21.5	57.7	34.9	63.7	45.6	50.6	45.6	23	44.6	39.6	16.8	17	111	89
ASR430F-02-08S,-F20	8						58.7	35.9									18.5	114	93
ASR430F-02-10S,-F20	10						53.8	31									21	105	82
ASR530F-02-06S,-F20	6	R1/4	21	18.5	24.3	25.3	62.9	36.5	67.3	49.2	55.8	50.8	25.9	49.8	44.8	18.8	17	150	127
ASR530F-02-08S,-F20	8						63.9	37.5									18.5	153	130
ASR530F-02-10S,-F20	10						59	32.6									21	143	120
ASR530F-02-12S,-F20	12						60.8	34.4									20.9	146	122
ASR530F-03-06S,-F20	6	R3/8	21	18.5	24.3	25.3	62.9	36.5	67.3	49.2	57.4	52.4	25.9	51	46	20	17	160	137
ASR530F-03-08S,-F20	8						63.9	37.5									18.5	163	140
ASR530F-03-10S,-F20	10						59	32.6									21	153	130
ASR530F-03-12S,-F20	12						60.8	34.4									20.9	156	133
ASR630F-03-10S,-F20	10	R3/8	25	18.5	29.7	30	62.8	32.6	86.3	65.5	67.6	60.1	27.7	61.2	53.7	20.6	21	237	219
ASR630F-03-12S,-F20	12			20.9			64.6	34.4									22	239	221
ASR630F-04-10S,-F20	10	R1/2	25	18.5	29.7	30	62.8	32.6	86.3	65.5	71.1	63.6	27.7	62.9	55.4	24.1	21	257	239
ASR630F-04-12S,-F20	12			20.9			64.6	34.4									22	259	239

Note 1) "d" indicates the applicable tubing O.D.

Note 2) L3 is the dimension for the variable set pressure type.

Note 3) L4 is the dimension for the fixed set pressure type.

Note 4) A1 and A2 are reference dimensions after installation.

Note 5) *1 is the weight for the variable set pressure type and *2 is that for the fixed set pressure type.

Series ASR/ASQ

Dimensions

Flow Valve: Series ASQ

Variable set pressure type

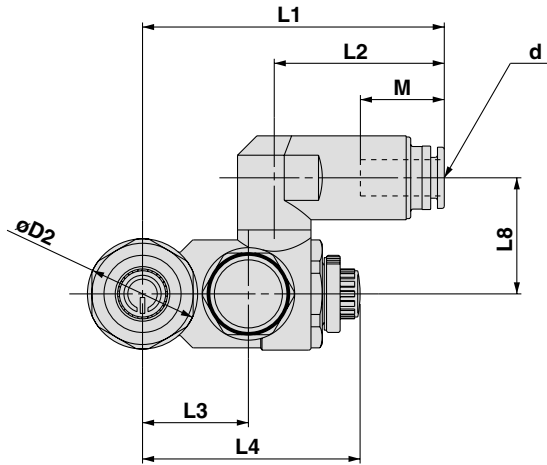

Fixed set pressure type

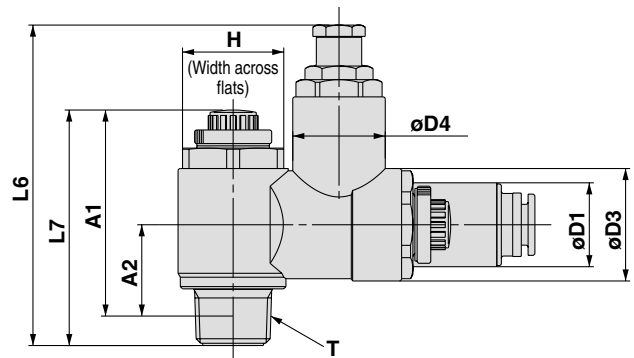
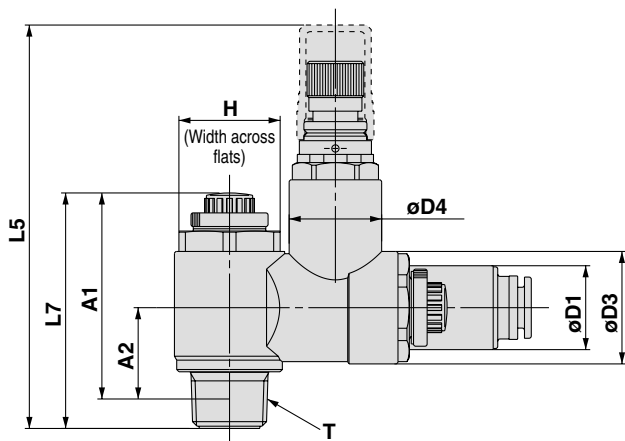
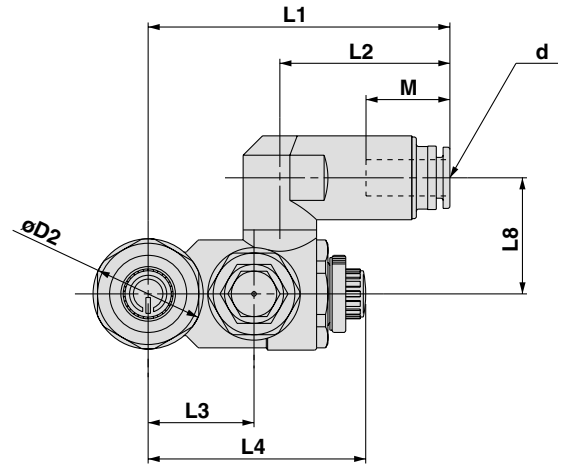

Model	Note 1) d	T	H	D1	D2	D3	D4	L1	L2	L3	L4		Note 2) L5	Note 3) L6	L7		L8	A1 Note 4)		Note 4) A2	M	Weight (g) Note 5)	
											MAX.	MIN.			MAX.	MIN.		MAX.	MIN.			*1	*2
ASQ430F-02-06S,-F20	6							61.6	34.9												17	136	114
ASQ430F-02-08S,-F20	8	R1/4	17	18.5	20	21.5	19.5	62.6	35.9	20.3	49.4	44.4	88.8	68.7	50.6	45.6	23	44.6	39.6	17.9	18.5	139	117
ASQ430F-02-10S,-F20	10							57.7	31												21	130	108
ASQ530F-02-06S,-F20	6							65.6	36.5												17	178	155
ASQ530F-02-08S,-F20	8							66.6	37.5												18.5	181	158
ASQ530F-02-10S,-F20	10	R1/4	21	18.5	24.3	24.8	20.4	61.7	32.6	23.4	53.5	48.5	92.2	72	55.8	50.8	25.6	49.8	44.8	19	21	172	149
ASQ530F-02-12S,-F20	12							63.5	34.4												22	174	151
ASQ530F-03-06S,-F20	6							65.6	36.5												17	188	165
ASQ530F-03-08S,-F20	8							66.6	37.5												18.5	191	168
ASQ530F-03-10S,-F20	10	R3/8	21	18.5	24.3	24.8	20.4	61.7	32.6	23.4	53.5	48.5	93.8	73.6	57.4	52.4	25.6	51	46	20.2	21	182	159
ASQ530F-03-12S,-F20	12							63.5	34.4												22	184	161
ASQ630F-03-10S,-F20	10							74.8	32.6												21	310	292
ASQ630F-03-12S,-F20	12	R3/8	25	18.5	29.7	30.7	30	76.6	34.4	30.8	74.3	66.8	107.9	86.9	67.6	60.1	28	61.2	53.7	20.8	22	312	294
ASQ630F-04-10S,-F20	10							74.8	32.6												21	330	312
ASQ630F-04-12S,-F20	12	R1/2	25	18.5	29.7	30.7	30	76.6	34.4	30.8	74.3	66.8	111.4	90.4	71.1	63.6	28	62.9	55.4	24.1	22	332	314

Note 1) "d" indicates the applicable tubing O.D..

Note 2) L5 is the dimension for the variable set pressure type.

Note 3) L6 is the dimension for the fixed set pressure type.

Note 4) A1 and A2 are reference dimensions after installation.

Note 5) *1 is the weight for the variable set pressure type and *2 is that for the fixed set pressure type.



Air Saving Valve Specific Product Precautions

Be sure to read before handling.

Selection

⚠ Warning

1. Confirm the specifications.

The products appearing in this catalog are designed for use only in compressed air (included vacuum pressure) systems.

Do not use outside the specified ranges of pressure, temperature, etc., as this may cause damage or malfunction. (Refer to specifications.)

Please consult with SMC if fluids other than compressed air (included vacuum pressure) are to be used.

Installation

⚠ Warning

1. Read the instruction manual carefully.

The instruction manual should be carefully read and fully understood before the product is installed and operated. Also, the manual should be kept where it can be easily referred to at any time.

2. Allow space for maintenance.

Allow the space necessary for maintenance and inspections.

3. Tighten screws with the proper tightening torque.

When mounting the product, tighten screws with the recommended torque.

Piping

⚠ Caution

1. Preparation before piping

Before piping is connected, it should be thoroughly blown out with air (flushing) or washed to remove chips, cutting oil and other debris from inside the pipe.

3. Wrapping of sealant tape

When screwing together pipes, fittings, etc., be certain that chips from the pipe threads and sealant material do not get inside the piping.

Further, when sealant tape is used, leave 1.5 to 2 thread ridges exposed at the end of the threads.

Air Supply

⚠ Warning

1. Types of fluid

This product is designed for use with compressed air. Please contact SMC if a different type of fluid is to be used.

Please contact SMC regarding products for general fluids, to confirm which fluids can be used.

2. A large amount of condensate

Pressurized air containing a large amount of condensate may cause malfunction of the pneumatic equipment. An air dryer or water separator should be installed upstream from the filters.

Air Supply

⚠ Caution

3. Drain flushing management

If the air filter drains are not flushed regularly, the condensate will flow downstream from the drains, resulting in malfunction of the pneumatic equipment.

In cases where drain flushing will be difficult, use of filters with auto drain is recommended.

For detailed information on the quality of compressed air, refer to Best Pneumatics Vol. 14.

4. Types of air

Do not use compressed air containing chemicals, salt, corrosive gases, synthetic oil which includes organic solvents, etc., which may cause damage or faulty operation.

Operating Environment

⚠ Warning

1. Do not use valves where there is direct contact with, or in atmospheres of, corrosive gases, chemicals, salt water, water or steam.

2. Provide shade in locations which receive direct sunlight.

3. Do not operate in locations where vibration or impact occurs.

4. Do not operate in locations where the product is exposed to direct heat radiation from a heat source at a close distance.

Maintenance

⚠ Warning

1. Maintenance should be performed in accordance with the procedures in the instruction manual.

Incorrect handling can cause damage or malfunction of machinery and equipment, etc.

2. Maintenance work

Compressed air can be dangerous if handled improperly. Element replacement and other maintenance etc., should be performed by personnel having sufficient knowledge and experience pertaining to pneumatic equipment, while also adhering to the product specifications.

3. Drain flushing

Condensate should be flushed from the air filter and other drains on a regular basis.

4. Pre-maintenance checks

When the product is to be removed, be sure to shut off the supply pressure, release compressed air in the pipelines and confirm an atmospheric release condition before proceeding.

5. Post-maintenance checks

After mounting, repair or renovation, supply compressed air and perform suitable function and leak tests. If an audible leak is detected or equipment does not operate properly, stop operation and confirm that mounting is correct.

6. Disassembly and modification is prohibited.

Do not disassemble or modify the main unit.

AS

ASP

ASN

AQ

ASV

AK

ASS

ASR

ASF



Air Saving Valve Specific Product Precautions

Be sure to read before handling.

Selection

⚠ Warning

1. The product cannot be used as a stop valve, of which zero leakage is required.

The specifications of the product allow a certain degree of leakage.

2. Confirm whether PTFE can be used.

The sealing compound contains PTFE (tetrafluoroethylene resin) powder. Make sure that it will not cause any problem in operation.

3. Keep the set pressure range of the outlet pressure of the pressure valve within 85% that of the inlet pressure.

If the value exceeds 85%, the pressure may become unstable, affected by the fluctuation of the inlet pressure.

Installation

⚠ Warning

1. Confirm that the lock nut is not loose.

If the lock nut is loose, there may be dangerous changes in actuator speed.

2. The number of opening and closing rotations of the needle valve and adjustment screw should be adjusted within the range of the specifications.

Since it has a pull-out stop mechanism, it will not rotate past the limit. Confirm the number of rotations for the product being used, as excessive turning of the needle will cause damage.

3. To adjust the speed, start with the needle in the completely closed position, and then adjust by opening gradually.

When the needle valve is opening, the actuator may jerk suddenly creating a dangerous situation.

Moreover, the needle valve is closed by turning clockwise, and opened by turning counterclockwise. Therefore, the actuator speed is reduced by turning clockwise and increased by turning counterclockwise.

When the product is used for an actuator operating vertically, the actuator may lurch depending on the load. For the adjustment method, please refer to "Selection and Adjustment" on page 15-16-6 to 15-16-7.

4. For installation and removal, tighten the body B by applying an appropriate wrench to the two opposite sides of the hexagon.

Using other parts may destroy the valve. For alignment after installation, rotate body A manually.

5. Do not use universal type fittings at a position where they are constantly rotated.

The fittings may be damaged.

6. The valve cannot be used if there are fluctuations of the load.

The piston rod may jerk during operation.

7. In case a closed-center solenoid valve is used, switch to the center position only after pressure charge inside the cylinder at the stroke end is completed.

If the pressure charge is insufficient, the piston rod may jerk after restart.

Tightening Torque

⚠ Caution

1. The proper tightening torque for pipe fittings is as shown in the table. As a rule, they should be tightened 2 to 3 turns with a tool after first tightening by hand. Be careful not to cause damage by over-tightening.

Male thread	Proper tightening torque N·m	Width across flats mm	Nominal size of adjustable angle wrench mm
1/4	12 to 14	17	200
3/8	22 to 24	21	200
1/2	28 to 30	25	250

Handling of One-Touch Fittings

⚠ Caution

1. Installation and Removal of Tubing for One-Touch Fittings

1) Installation of tubing

- (1) Using tube cutters TK-1, 2 or 3, take a tube having no flaws on its periphery and cut it off at a right angle. Do not use pinchers, nippers or scissors, etc. The tubing might be cut diagonally or flattened, making installation impossible or causing problems such as disconnection and leakage. Allow extra length for the tubing.
- (2) Hold the tubing and push it in slowly, inserting it securely all the way into the fitting.
- (3) After inserting the tubing, pull on it lightly to confirm that it will not come out. If it is not installed securely all the way into the fitting, problems such as leakage or disconnection of the tubing can occur.

2) Removal of tubing

- (1) Push in the release button sufficiently, pressing the collar evenly around its circumference.
- (2) Pull out the tubing while holding down the release button so that it does not pop out. If the release button is not pressed down sufficiently, there will be increased bite on the tubing and it will become more difficult to pull it out.
- (3) When the removed tubing is to be used again, first cut off the section of the tubing which has been chewed. Using the chewed portion of the tube as it is can cause problems such as leakage or difficulty in removing the tubing.

Operating

⚠ Caution

1. The valve cannot be used if the same pressure is required for both the working and return strokes. The pressure valve and flow valve are designed to save air by the difference in the operating pressure.
2. Install a flow valve on the working side which requires the cylinder output and a pressure valve on the return side. The cylinder may not operate if the valves are installed on the wrong sides.

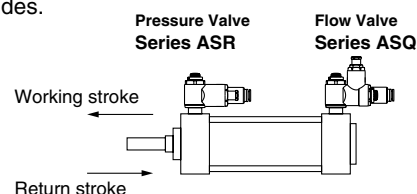



3. If a closed-center, exhaust-center, pressure-center or perfect solenoid valve is used and the solenoid valve is set at the center position, the cylinder may move to the position where the pressure balance and load balance are achieved.



Safety Instructions

These safety instructions are intended to prevent a hazardous situation and/or equipment damage. These instructions indicate the level of potential hazard by labels of "Caution", "Warning" or "Danger". To ensure safety, be sure to observe ISO 4414 ^{Note 1)}, JIS B 8370 ^{Note 2)} and other safety practices.

 **Caution** : Operator error could result in injury or equipment damage.

 **Warning** : Operator error could result in serious injury or loss of life.

 **Danger** : In extreme conditions, there is a possible result of serious injury or loss of life.

Note 1) ISO 4414: Pneumatic fluid power--General rules relating to systems.

Note 2) JIS B 8370: General Rules for Pneumatic Equipment

Warning

1. The compatibility of pneumatic equipment is the responsibility of the person who designs the pneumatic system or decides its specifications.

Since the products specified here are used in various operating conditions, their compatibility for the specific pneumatic system must be based on specifications or after analysis and/or tests to meet your specific requirements. The expected performance and safety assurance will be the responsibility of the person who has determined the compatibility of the system. This person should continuously review the suitability of all items specified, referring to the latest catalog information with a view to giving due consideration to any possibility of equipment failure when configuring a system.

2. Only trained personnel should operate pneumatically operated machinery and equipment.

Compressed air can be dangerous if an operator is unfamiliar with it. Assembly, handling or repair of pneumatic systems should be performed by trained and experienced operators.

3. Do not service machinery/equipment or attempt to remove components until safety is confirmed.

1. Inspection and maintenance of machinery/equipment should only be performed once measures to prevent falling or runaway of the driver objects have been confirmed.
2. When equipment is to be removed, confirm the safety process as mentioned above. Cut the supply pressure for this equipment and exhaust all residual compressed air in the system.
3. Before machinery/equipment is restarted, take measures to prevent shooting-out of cylinder piston rod, etc.

4. Contact SMC if the product is to be used in any of the following conditions:

1. Conditions and environments beyond the given specifications, or if product is used outdoors.
2. Installation on equipment in conjunction with atomic energy, railway, air navigation, vehicles, medical equipment, food and beverages, recreation equipment, emergency stop circuits, clutch and brake circuits in press applications, or safety equipment.
3. An application which has the possibility of having negative effects on people, property, or animals, requiring special safety analysis.



Common Precautions

Be sure to read before handling.

For detailed precautions on every series, refer to main text.

Selection

Warning

1. Confirm the specifications.

Products represented in this catalog are designed for use in compressed air applications only (including vacuum), unless otherwise indicated.

Do not use the product outside their design parameters.

Please contact SMC when using the products in applications other than compressed air (including vacuum).

Mounting

Warning

1. Instruction manual

Install the products and operate them only after reading the instruction manual carefully and understanding its contents. Also keep the manual where it can be referred to as necessary.

2. Securing the space for maintenance

When installing the products, please allow access for maintenance.

3. Tightening torque

When installing the products, please follow the listed torque specifications.

Piping

Caution

1. Before piping

Make sure that all debris, cutting oil, dust, etc. are removed from the piping.

2. Wrapping of pipe tape

When screwing piping or fittings into ports, ensure that chips from the pipe threads or sealing material do not get inside the piping. Also, when the pipe tape is used, leave 1.5 to 2 thread ridges exposed at the end of the threads.

Air Supply

Warning

1. Operating fluid

Please consult with SMC when using the product in applications other than compressed air (including vacuum).

Regarding products for general fluid, please ask SMC about applicable fluids.

2. Install an air dryer, aftercooler, etc.

Excessive condensate in a compressed air system may cause valves and other pneumatic equipment to malfunction.

Installation of an air dryer, after cooler etc. is recommended.

3. Drain flushing

If condensate in the drain bowl is not emptied on a regular basis, the bowl will over flow and allow the condensate to enter the compressed air lines.

If the drain bowl is difficult to check and remove, it is recommended that a drain bowl with the auto-drain option be installed.

For compressed air quality, refer to "Air Preparation Equipment" catalog.

4. Use clean air

If the compressed air supply is contaminated with chemicals, synthetic materials, corrosive gas, etc., it may lead to break down or malfunction.

Operating Environment

Warning

1. Do not use in environments where the product is directly exposed to corrosive gases, chemicals, salt water, water or steam.

2. Do not expose the product to direct sunlight for an extended period of time.

3. Do not use in a place subject to heavy vibrations and/or shocks.

4. Do not mount the product in locations where it is exposed to radiant heat.

Maintenance

Warning

1. Maintenance procedures are outlined in the operation manual.

Not following proper procedures could cause the product to malfunction and could lead to damage to the equipment or machine.

2. Maintenance work

If handled improperly, compressed air can be dangerous.

Assembly, handling and repair of pneumatic systems should be performed by qualified personnel only.

3. Drain flushing

Remove drainage from air filters regularly. (Refer to the specifications.)

4. Shut-down before maintenance

Before attempting any kind of maintenance make sure the supply pressure is shut of and all residual air pressure is released from the system to be worked on.

5. Start-up after maintenance and inspection

Apply operating pressure and power to the equipment and check for proper operation and possible air leaks. If operation is abnormal, please verify product set-up parameters.

6. Do not make any modifications to be product.

Do not take the product apart.

Quality Assurance Information (ISO 9001, ISO 14001)

Reliable quality of products in the global market

To enable our customers throughout the world to use our products with even greater confidence, SMC has obtained certification for international standards “ISO 9001” and “ISO 14001”, and created a complete structure for quality assurance and environmental controls. SMC products pursue to meet its customers’ expectations while also considering company’s contribution in society.

Quality management system ISO 9001

This is an international standard for quality control and quality assurance. SMC has obtained a large number of certifications in Japan and overseas, providing assurance to our customers throughout the world.



Environmental management system ISO 14001

This is an international standard related to environmental management systems and environmental inspections. While promoting environmentally friendly automation technology, SMC is also making diligent efforts to preserve the environment.



SMC’s quality control system



Quality policies



Quality control activities

SMC Product Conforming to Inter

SMC products complying with EN/ISO, CSA/UL standards are supporting



The CE mark indicates that machines and components meet essential requirements of all the EC Directives applied.

It has been obligatory to apply CE marks indicating conformity with EC Directives when machines and components are exported to the member Nations of the EU.

Once "A manufacturer himself" declares a product to be safe by means of CE marking (declaration of conformity by manufacturer), free distribution inside the member Nations of the EU is permissible.

■ CE Mark

SMC provides CE marking to products to which EMC and Low Voltage Directives have been applied, in accordance with CETOP (European hydraulics and pneumatics committee) guide lines.

■ As of February 1998, the following 18 countries will be obliged to conform to CE mark legislation

Iceland, Ireland, United Kingdom, Italy, Austria, Netherlands, Greece, Liechtenstein, Sweden, Spain, Denmark, Germany, Norway, Finland, France, Belgium, Portugal, Luxembourg

■ EC Directives and Pneumatic Components

• Machinery Directive

The Machinery Directive contains essential health and safety requirements for machinery, as applied to industrial machines e.g. machine tools, injection molding machines and automatic machines. Pneumatic equipment is not specified in Machinery Directive. However, the use of SMC products that are certified as conforming to EN Standards, allows customers to simplify preparation work of the Technical Construction File required for a Declaration of Conformity.

• Electromagnetic Compatibility (EMC) Directive

The EMC Directive specifies electromagnetic compatibility. Equipment which may generate electromagnetic interference or whose function may be compromised by electromagnetic interference is required to be immune to electromagnetic affects (EMS/immunity) without emitting excessive electromagnetic affects (EMI/emission).

• Low Voltage Directive

This directive is applied to products, which operate above 50 VAC to 1000 VAC and 75 VDC to 1500 VDC operating voltage, and require electrical safety measures to be introduced.

• Simple Pressure Vessels Directive

This directive is applied to welded vessels whose maximum operating pressure (PS) and volume of vessel (V) exceed 50 bar/L. Such vessels require EC type examination and then CE marking.

national Standards

you to comply with EC directives and CSA/UL standards.



■ CSA Standards & UL Standards

UL and CSA standards have been applied in North America (U.S.A. and Canada) symbolizing safety of electric products, and are defined to mainly prevent danger from electric shock or fire, resulting from trouble with electric products. Both UL and CSA standards are acknowledged in North America as the first class certifying body. They have a long experience and ability for issuing product safety certificate. Products approved by CSA or UL standards are accepted in most states and governments beyond question.

Since CSA is a test certifying body as the National Recognized Testing Laboratory (NRTL) within the jurisdiction of Occupational Safety and Health Administration (OSHA), SMC was tested for compliance with CSA Standards and UL Standards at the same time and was approved for compliance with the two Standards. The above CSA NRTL/C logo is described on a product label in order to indicate that the product is approved by CSA and UL Standards.

■ TSSA (MCCR) Registration Products

TSSA is the regulation in Ontario State, Canada. The products that the operating pressure is more than 5 psi (0.03 MPa) and the piping size is bigger than 1 inch. fall into the scope of TSSA regulation.

Products conforming to CE Standard



With CE symbol for simple visual recognition

In this catalog each accredited product series is indicated with a CE mark symbol. However, in some cases, every available models may not meet CE compliance. Please visit our web site for the latest selection of available models with CE mark.

<http://www.smcworld.com>

SMC's Global Service Network

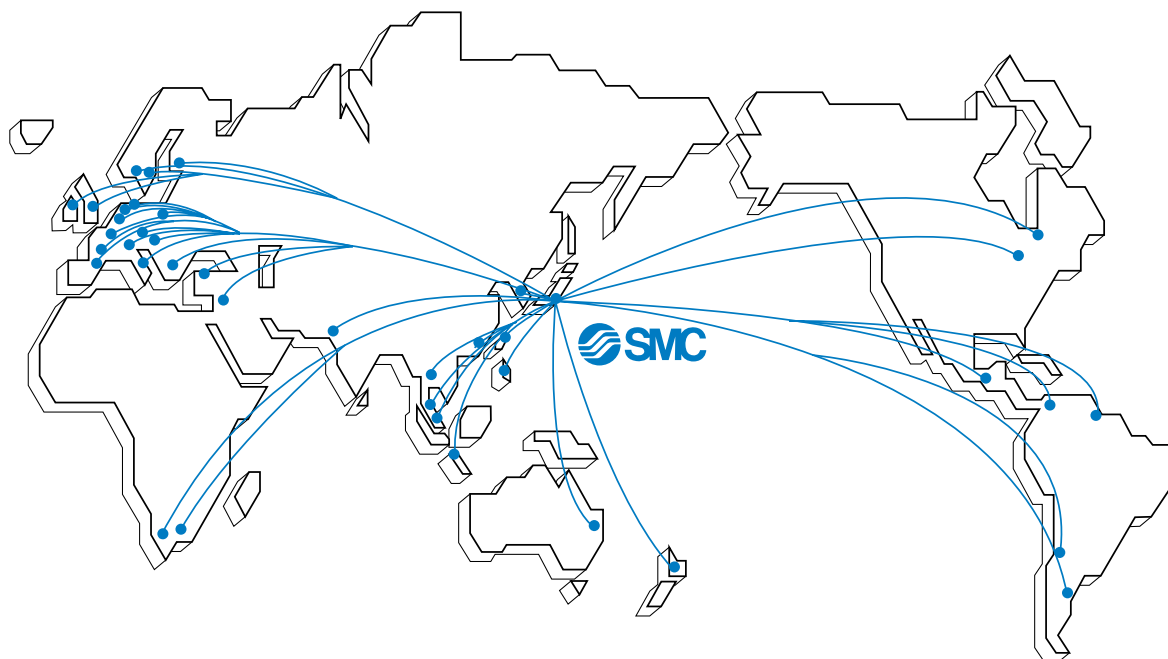

America

U.S.A. **SMC Corporation of America**

3011 North Franklin Road Indianapolis, IN 46226, U.S.A.
TEL: 317-899-4440 FAX: 317-899-3102

CANADA **SMC Pneumatics (Canada) Ltd.**

6768 Financial Drive Mississauga, Ontario, L5N 7J6 Canada
TEL: 905-812-0400 FAX: 905-812-8686

MEXICO **SMC Corporation (Mexico), S.A. DE C.V.**

Carr. Silao-Trejo K.M. 2.5 S/N, Predio San Jose del Duranzo
C.P. 36100, Silao, Gto., Mexico
TEL: 472-72-2-55-00 FAX: 472-72-2-59-44/2-59-46

CHILE **SMC Pneumatics (Chile) S.A.**

Av. La Montaña 1,115 km. 16,5 P. Norte Parque
Industrial Valle Grande, Lampa Santiago, Chile
TEL: 02-270-8600 FAX: 02-270-8601

ARGENTINA **SMC Argentina S.A.**

Teodoro Garcia 3860 (1427) Buenos Aires, Argentina
TEL: 011-4555-5762 FAX: 011-4555-5762

BOLIVIA **SMC Pneumatics Bolivia S.R.L.**

Avenida Beni Numero 4665
Santa Cruz de la Sierra-Casilla de Correo 2281, Bolivia
TEL: 591-3-3428383 FAX: 591-3-3449900

VENEZUELA **SMC Neumatica Venezuela S.A.**

Apartado 40152, Avenida Nueva Granada, Edificio Wanlac,
Local 5, Caracas 1040-A, Venezuela
TEL: 2-632-1310 FAX: 2-632-3871

PERU (Distributor) **IMPECO Automatizacion Industrial S.A.**

AV. Canevaro 752, Lince, Lima, Peru
TEL: 1-471-6002 FAX: 1-471-0935

URUGUAY (Distributor) **BAKO S.A.**

Galicia 1650 esq. Gaboto C.P. 11200, Montevideo, Uruguay
TEL: 2-401-6603 FAX: 2-409-4306

BRAZIL **SMC Pneumaticos Do Brasil Ltda.**

Rua. Dra. Maria Fidelis, nr. 130, Jardim Piraporinha-Diadema-S.P.
CEP: 09950-350, Brasil
TEL: 11-4051-1177 FAX: 11-4071-6636

COLOMBIA (Distributor) **Airmatic Ltda.**

Calle 18 69-05 Apart. Aereo 081045 Santa Fe de Bogotá, Colombia
TEL: 1-424-9240 FAX: 1-424-9260

Europe

U.K. **SMC Pneumatics (U.K.) Ltd.**

Vincent Avenue, Crownhill, Milton Keynes, MK8 0AN, Buckinghamshire, U.K.
TEL: 01908-563888 FAX: 01908-561185

GERMANY **SMC Pneumatik GmbH**

Boschring 13-15 D-63329 Egelsbach, Germany
TEL: 06103-4020 FAX: 06103-402139

ITALY **SMC Italia S.p.A.**

Via Garibaldi 62 I-20061 Carugate Milano, Italy
TEL: 02-9271365 FAX: 02-9271365

FRANCE **SMC Pneumatique S.A.**

1 Boulevard de Strasbourg, Parc Gustave Eiffel, Bussy Saint Georges, F-77600
Marne La Vallee Cedex 3 France
TEL: 01-64-76-10-00 FAX: 01-64-76-10-10

SWEDEN **SMC Pneumatics Sweden AB**

Ekhagsvägen 29-31, S-141 05 Huddinge, Sweden
TEL: 08-603-07-00 FAX: 08-603-07-10

SWITZERLAND **SMC Pneumatik AG**

Dorfstrasse 7, Postfach 117, CH-8484 Weisslingen, Switzerland
TEL: 052-396-3131 FAX: 052-396-3191

AUSTRIA **SMC Pneumatik GmbH (Austria)**

Girakstrasse 8, A-2100 Korneuburg, Austria
TEL: 0-2262-6228-0 FAX: 0-2262-62285

SPAIN **SMC España, S.A.**

Zuazobidea 14 Pol. Ind. Júndiz 01015 Vitoria, Spain
TEL: 945-184-100 FAX: 945-184-510

IRELAND **SMC Pneumatics (Ireland) Ltd.**

2002 Citywest Business Campus, Naas Road, Saggart, Co. Dublin, Ireland
TEL: 01-403-9000 FAX: 01-466-0385

NETHERLANDS (Associated company) **SMC Pneumatics BV**

De Ruyterkade 120, NL-1011 AB Amsterdam, Netherlands
TEL: 020-5318888 FAX: 020-5318880

GREECE (Distributor) **S.Parianopoulos S.A.**

7, Konstantinoupoleos Street 11855 Athens, Greece
TEL: 01-3426076 FAX: 01-3455578

DENMARK **SMC Pneumatik A/S**

Knudsminde 4 B DK-8300
Odder, Denmark
TEL: 70252900 FAX: 70252901

Europe

FINLAND **SMC Pneumatics Finland OY**

PL72, Tiistinniityntie 4, SF-02231 ESP00, Finland
TEL: 09-8595-80 FAX: 09-8595-8595

NORWAY **SMC Pneumatics Norway A/S**

Vollsveien 13C, Granfoss Næringspark N-1366 LYSAKER, Norway
TEL: 67-12-90-20 FAX: 67-12-90-21

BELGIUM (Distributor) **SMC Pneumatics N.V./S.A.**

Nijverheidsstraat 20 B-2160 Wommelgem Belguim
TEL: 03-355-1464 FAX: 03-355-1466

POLAND **SMC Industrial Automation Polska Sp.z.o.o.**

ul. Konstruktorska 11A, PL-02-673 Warszawa, Poland
TEL: 022-548-5085 FAX: 022-548-5087

TURKEY (Distributor) **Entek Pnömatik San.ve Tic. Ltd. Sti**

Perpa Tic. Merkezi Kat:11 No.1625 80270 Okmeydani Istanbul, Türkiye
TEL: 0212-221-1512 FAX: 0212-221-1519

RUSSIA **SMC Pneumatik LLC.**

36/40 Sredny prospect V.O. St. Petersburg 199004, Russia
TEL: 812-118-5445 FAX: 812-118-5449

CZECH **SMC Industrial Automation CZ s.r.o.**

Hudcova 78a, CZ-61200 Brno, Czech Republic
TEL: 05-4121-8034 FAX: 05-4121-8034

HUNGARY **SMC Hungary Ipari Automatizálási kft.**

Budafoki ut 107-113 1117 Budapest
TEL: 01-371-1343 FAX: 01-371-1344

ROMANIA **SMC Romania S.r.l.**

Str. Frunzei, Nr. 29, Sector 2, Bucharest, Romania
TEL: 01-3205111 FAX: 01-3261489

SLOVAKIA **SMC Priemyselná automatizácia, s.r.o.**

Nova 3, SK-83103 Bratislava
TEL: 02-4445-6725 FAX: 02-4445-6028

SLOVENIA **SMC Industrijska Avtomatila d.o.o.**

Grajski trg 15, SLO- 8360 Zuzemberk, Slovenia
TEL: 07388-5240 FAX: 07388-5249

LATVIA **SMC Pneumatics Latvia SIA**

Šmerļa ielā 1-705, Rīga LV-1006
TEL: 777 94 74 FAX: 777 94 75

SOUTH AFRICA (Distributor) **Hyflo Southern Africa (Pty.) Ltd.**

P.O.Box 240 Paardeneiland 7420 South Africa
TEL: 021-511-7021 FAX: 021-511-4456

EGYPT (Distributor) **Saadani Trading & Ind. Services**

15 Sebaai Street, Miami 21411 Alexandria, Egypt
TEL: 3-548-50-34 FAX: 3-548-50-34

Oceania/Asia

AUSTRALIA **SMC Pneumatics (Australia) Pty.Ltd.**

14-18 Hudson Avenue Castle Hill NSW 2154, Australia
TEL: 02-9354-8222 FAX: 02-9894-5719

NEW ZEALAND **SMC Pneumatics (New Zealand) Ltd.**

8C Sylvia Park Road Mt.Wellington Auckland, New Zealand
TEL: 09-573-7007 FAX: 09-573-7002

TAIWAN **SMC Pneumatics (Taiwan) Co.,Ltd.**

17, Lane 205, Nansan Rd., Sec.2, Luzhu-Hsiang, Taoyuan-Hsien, TAIWAN
TEL: 03-322-3443 FAX: 03-322-3387

HONG KONG **SMC Pneumatics (Hong Kong) Ltd.**

29/F, Clifford Centre, 778-784 Cheung, Sha Wan Road, Lai Chi Kok, Kowloon, Hong Kong
TEL: 2744-0121 FAX: 2785-1314

SINGAPORE **SMC Pneumatics (S.E.A.) Pte. Ltd.**

89 Tuas Avenue 1, Jurong Singapore 639520
TEL: 6861-0888 FAX: 6861-1889

PHILIPPINES **SHOKETSU SMC Corporation**

Unit 201 Common Goal Tower, Madrigal Business Park, Ayala Alabang Muntinlupa, Philippines
TEL: 02-8090565 FAX: 02-8090586

MALAYSIA **SMC Pneumatics (S.E.A.) Sdn. Bhd.**

Lot 36 Jalan Delima1/1, Subang Hi-Tech Industrial Park, Batu 3 40000 Shah Alam Selangor, Malaysia
TEL: 03-56350590 FAX: 03-56350602

SOUTH KOREA **SMC Pneumatics Korea Co., Ltd.**

Woolim e-BIZ Center (Room 1008), 170-5, Guro-Dong, Guro-Gu, Seoul, 152-050, South Korea
TEL: 02-3219-0700 FAX: 02-3219-0702

CHINA **SMC (China) Co., Ltd.**

7 Wan Yuan St. Beijing Economic & Technological Development Zone 100176, China
TEL: 010-67882111 FAX: 010-67881837

THAILAND **SMC Thailand Ltd.**

134/6 Moo 5, Tiwanon Road, Bangkadi, Amphur Muang, Patumthani 12000, Thailand
TEL: 02-963-7099 FAX: 02-501-2937

INDIA **SMC Pneumatics (India) Pvt. Ltd.**

D-107 to 112, Phase-2, Extension, Noida, Dist. Gautaim Budh Nagar, U.P. 201 305, India
TEL: (0120)-4568730 FAX: 0120-4568933

INDONESIA (Distributor) **P.T. Riyadi Putera Makmur**

Jalan Hayam Wuruk Komplek Glodok Jaya No. 27-28 Jakarta 11180 Indonesia
TEL: 021-625 5548 FAX: 021-625 5888

PAKISTAN (Distributor) **Jubilee Corporation**

First Floor Mercantile Centre, Newton Road Near Boulton Market P.O. Box 6165 Karachi 74000 Pakistan
TEL: 021-243-9070/8449 FAX: 021-241-4589

ISRAEL (Distributor) **Baccara Automation Control**

Kvutza Geva 18915 Israel
TEL: 04-653-5960 FAX: 04-653-1445

SAUDI ARABIA (Distributor) **Assaggaff Trading Est.**

P.O. Box 3385 Al-Amir Majed Street, Jeddah-21471, Saudi Arabia
TEL: 02-6761574 FAX: 02-6708173