

Card Motor

The transportation, pushing and length measurement systems have been miniaturized through the use of a linear motor.

New



RoHS

Weight
4.6 oz
(130 g)
Stroke: 10 mm

Thickness
9 mm

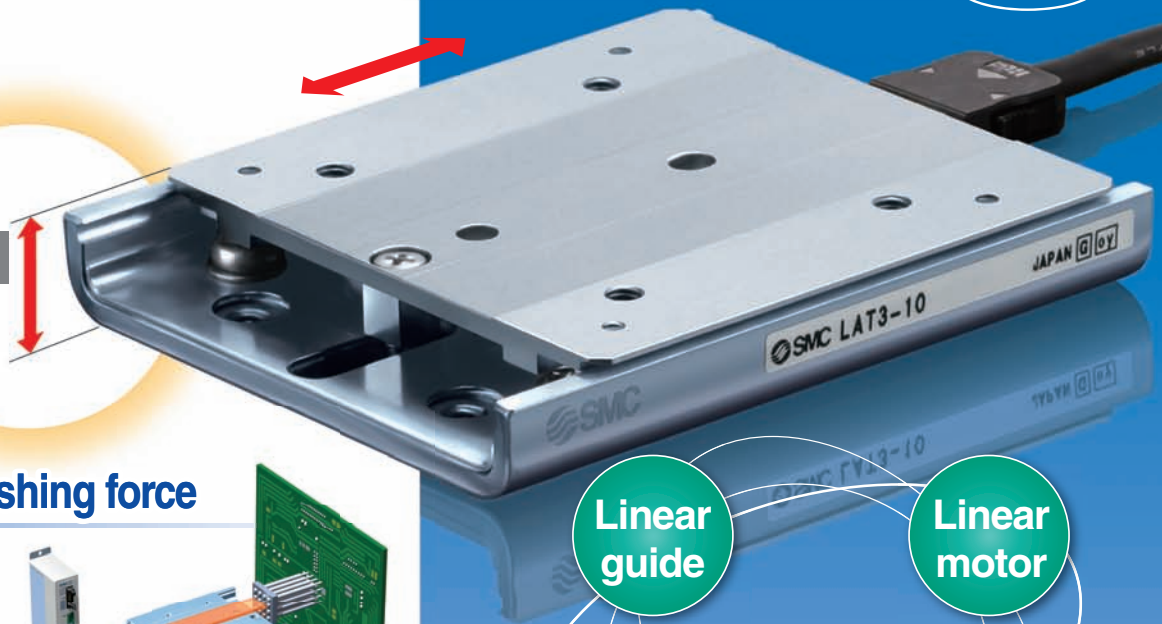

Maximum pushing force

6 N

Pushing a very little load

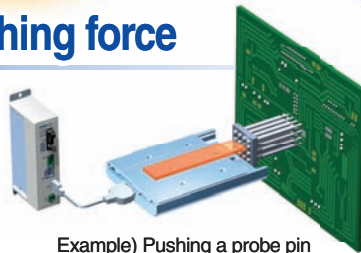

Example) Pushing a probe pin

Positioning repeatability

±5 μm

Positioning a workpiece

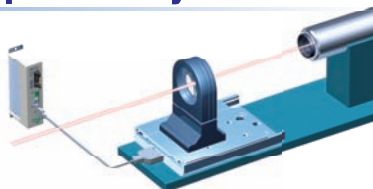

Example) Lens focusing

Pushing measurement accuracy

±10 μm

Parts measurement

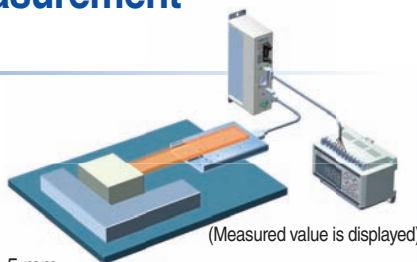

(Measured value is displayed)

Load mass 100 g, Stroke 5 mm

Maximum operating frequency

500 cpm

Rejection of non-conforming products, etc.



Linear guide

Linear motor

Displacement sensor

3 functions in 1 unit

- Easy programming (Takt time entry)

Just input

3 parameters:

Positioning time,

Target position,

Load mass.



Series LAT3



CAT.NAS100-96A

Card Motor

Compact and lightweight

Model	W (mm)	L (mm)	H (mm)	Weight oz (g)
LAT3□-10	50	60	9	4.6 (130)
LAT3□-20		90		6.7 (190)
LAT3□-30		120		8.8 (250)

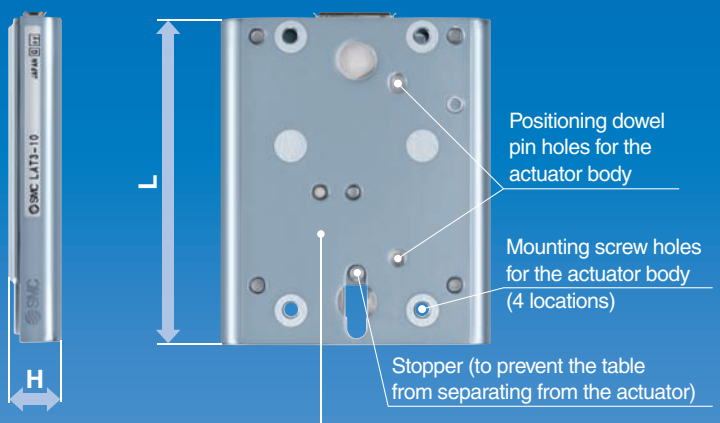
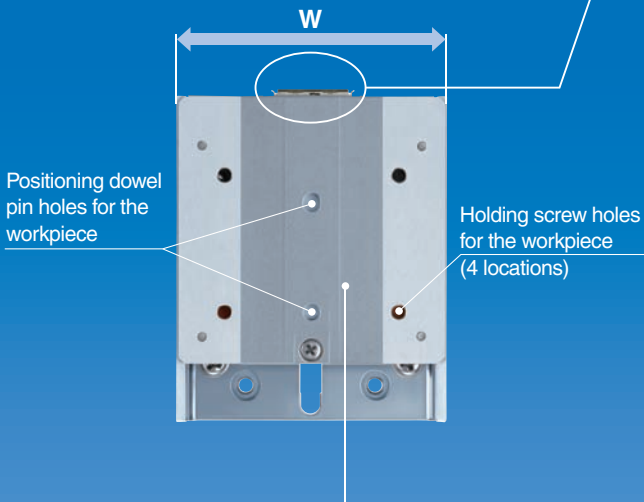
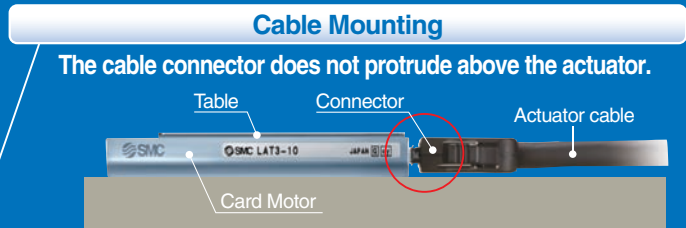

Workpiece Mounting
Positioning dowel pin holes on the workpiece and unit holding parts as standard

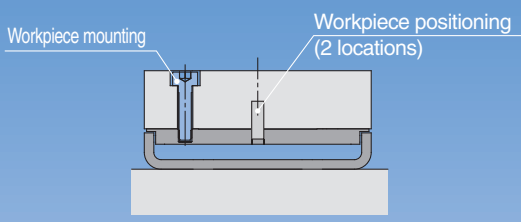

Body Mounting
2 body mounting options

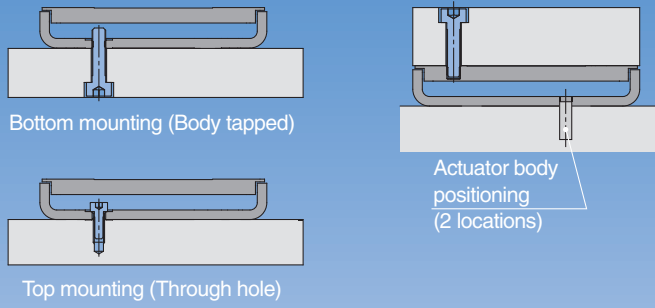

Series Variations

Model	Stroke	Sensor (Optical linear encoder)	Linear motor	Linear guide	Pushing	Positioning repeatability	Pushing measurement	Maximum load mass		Maximum speed
		Resolution	Type	Type	Instantaneous max. thrust	Accuracy	Accuracy	Horizontal	Vertical	
LAT3F	10	1.25 μm	Moving magnetic type linear motor	Linear guide with circulating balls	1.17 lbf (5.2 N)	±5 μm	±10 μm	17.6 oz (500 g)	3.5 oz (100 g)	400 mm/s
	20				1.35 lbf (6 N)				1.8 oz (50 g)	
LAT3	30	30 μm			1.23 lbf (5.5 N)	±90 μm	±100 μm			

Structure and Working Principle

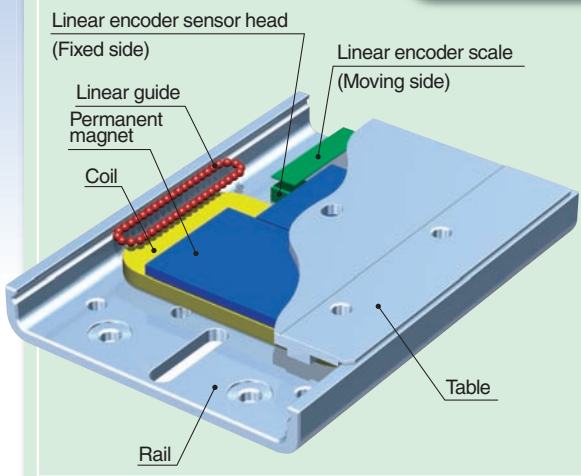

The permanent magnet is mounted on the bottom side of the table, and the coil is mounted on the top surface of the rail. When current is supplied to the coil, a north pole (N) is generated in the middle of the top surface of the coil. This north pole attracts the south pole (S) of the permanent magnet on the left and repels the north pole on the right, and these attracting and repelling forces generate the thrust force. Therefore, thrust force is applied to the table in the right direction, and the table moves to the right.

When current is applied to the coil in the reverse direction, a south pole will be generated in the middle of the top surface of the coil. Similarly, a thrust force will be applied to the table in the left direction, and the table moves to the left.

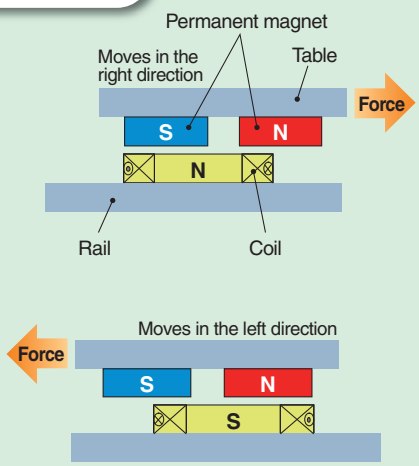

Takt Time Entry

The controller automatically calculates the speed, acceleration and deceleration after the user has entered how many seconds it should take for the Card Motor table to move to the target position. Therefore, there is no need to enter the speed, acceleration and deceleration.



Takt Time Entry Method

Step 1 Basic settings

Select the setting for each item described below and register it to the controller by clicking [Setup].

- A** [Card Motor Product Number]: Select the product number of the applicable Card Motor.
- B** [Method to Return to Home Position]: Select home position.
- C** [Card Motor Mounting Orientation]: Select horizontal or vertical.
- D** [Step Data Input Version]: Select takt time entry method.

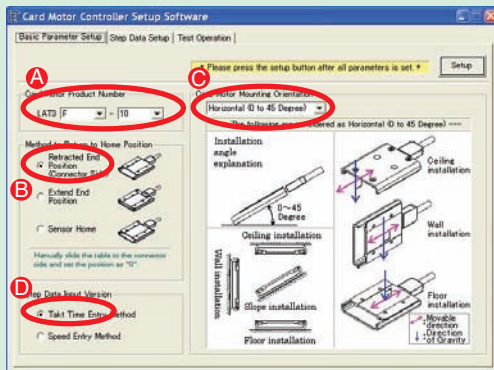

Step 2 Setting of operating conditions -Operation type selection-

E Select the [Step Data Setup] page.

F Select "Operation" type.

Position For transporting a workpiece to a specific position

Pushing For applying force to a workpiece or for measuring the size of a workpiece

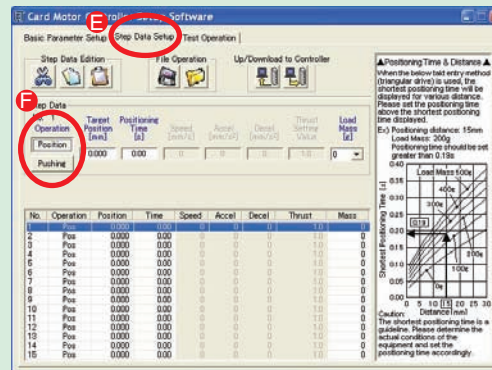

Step 3 Setting of operating conditions -Entering of the operating values-

<Positioning operation>

Items to enter

- G** **Target position [mm]** Distance from the home position (origin) to the target position
- H** **Positioning time [s]** Time required to move to the target position
- I** **Load mass [g]** Select the approximate weight of jigs or workpieces mounted on the Card Motor table.

<Pushing operation>

Items to enter

- G** **Target position [mm]**
- H** **Positioning time [s]** + **J** **Thrust setting value** Force to be applied
- I** **Load mass [g]**

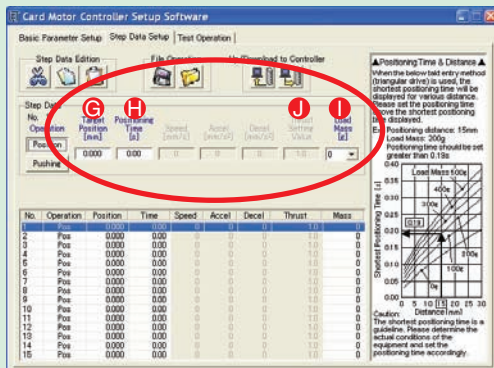

Step 4 Setting completed (Download)

After the operating conditions have been set,

K Click the [Download] button to complete the settings.

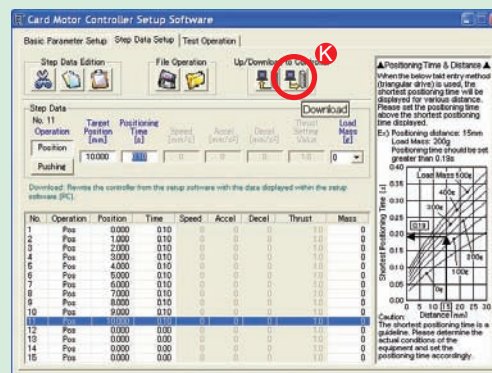

* Refer to the operation manual for details.

Series LAT3 Model Selection 1

Selection Procedure for Positioning Operation (Refer to Front matter 3 and 4 for **Fig.1, 2, 3, 4, 5** and **Table 1, 2, 3**.)

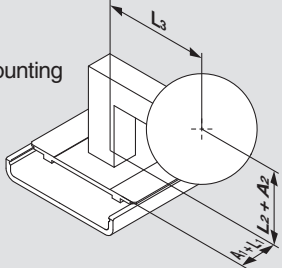
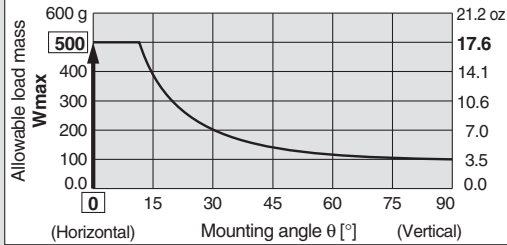
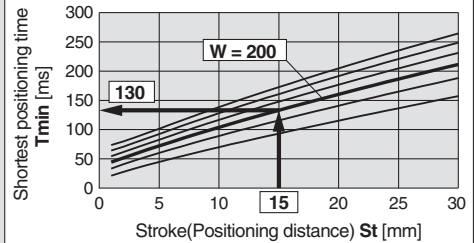
Selection Procedure	Formula/Data	Selection Example																					
<p>1 Operating conditions</p> <p>List the operating conditions with consideration to the mounting orientation and shape of the workpiece.</p> <p>2 Select an actuator temporarily.</p> <p>Select a model temporarily based on the required positioning repeatability and stroke.</p> <p>3 Check the load mass and load factor.</p> <p>Find the allowable load mass W_{max} [g] from the graph.</p> <p>*Confirm that the applied load mass W [g] does not exceed the allowable load mass.</p> <p>From Table 1, find the correction values for the distances to the moment center. Calculate the static moment M [N·m].</p> <p>From Table 3, find the allowable moment M_{max} [N·m]. Calculate the load factor α_n for the static moments.</p> <p>*Confirm that the total sum of the guide load factors for the static moments does not exceed 1.</p> <p>4 Check the positioning time.</p> <p>Find the shortest positioning time T_{min} [ms] from the graph.</p> <p>*Confirm that the positioning time T_p [ms] is longer than the shortest positioning time.</p>	<ul style="list-style-type: none"> Stroke St [mm] Load mass W [g] Mounting orientation Mounting angle θ [°] Fig.2 Amount of overhang Ln [mm] Fig.1 Correction values for the distances to the moment center An [mm] Fig.1 Table 1 Positioning time T_p [ms] Positioning repeatability [μm] <p>Table 2</p> <table border="1"> <thead> <tr> <th>Model</th> <th>LAT3-10</th> <th>LAT3F-10</th> <th>LAT3-20</th> <th>LAT3F-20</th> <th>LAT3-30</th> <th>LAT3F-30</th> </tr> </thead> <tbody> <tr> <td>Stroke [mm]</td> <td colspan="2">10</td> <td colspan="2">20</td> <td colspan="2">30</td> </tr> <tr> <td>Positioning repeatability [μm]</td> <td>± 90</td> <td>± 5</td> <td>± 90</td> <td>± 5</td> <td>± 90</td> <td>± 5</td> </tr> </tbody> </table> <p>W_{max} Fig.2</p> <p>$W \leq W_{max}$</p> <p>An Table 1</p> <p>$M = W/1000 \cdot 9.8 (Ln + An)/1000$</p> <p>$M_{max}$ Table 3</p> <p>$\alpha = M/M_{max}$</p> <p>$\sum \alpha_p + \alpha_y + \alpha_r \leq 1$</p> <p>$T_{min}$ Fig.3</p> <p>$T_p \geq T_{min}$</p>	Model	LAT3-10	LAT3F-10	LAT3-20	LAT3F-20	LAT3-30	LAT3F-30	Stroke [mm]	10		20		30		Positioning repeatability [μ m]	± 90	± 5	± 90	± 5	± 90	± 5	<p>15 mm 200 g Horizontal table mounting $\theta = 0^\circ$ $L_1 = -10$ mm $L_2 = 30$ mm $L_3 = 35$ mm $T_p = 200$ ms 100 μm</p>  <p>From Table 2, temporarily select the LAT3-20, which satisfies the positioning repeatability 100 μm and the minimum stroke that satisfies the stroke $St = 15$</p> <p>From Fig. 2: $\theta = 0$, find $W_{max} = 500$ As $W = 200 < W_{max} = 500$, the selected model can be used.</p>  <p>From Table 1, $A_1 = 32.5$</p> <p>Pitch moment</p> <p>$M_p = 200/1000 \times 9.8 (-10 + 32.5)/1000 = 0.044$</p> <p>From Table 3, $M_{pmax} = 0.3$ $\alpha_p = 0.044/0.3 = 0.15$</p> <p>Roll moment</p> <p>$M_r = 200/1000 \times 9.8 \times 35/1000 = 0.069$</p> <p>From Table 3, $M_{rmax} = 0.2$ $\alpha_r = 0.069/0.2 = 0.35$ $\sum \alpha_n = 0.15 + 0.35 = 0.5 \leq 1$, thus, the selected model can be used.</p> <p>From Fig. 3: $St = 15$ and $W = 200$, find $T_{min} = 130$ As $T_p = 200 \geq T_{min} = 130$, the selected model can be used.</p> 
Model	LAT3-10	LAT3F-10	LAT3-20	LAT3F-20	LAT3-30	LAT3F-30																	
Stroke [mm]	10		20		30																		
Positioning repeatability [μ m]	± 90	± 5	± 90	± 5	± 90	± 5																	

Selection Procedure for Pushing Operation

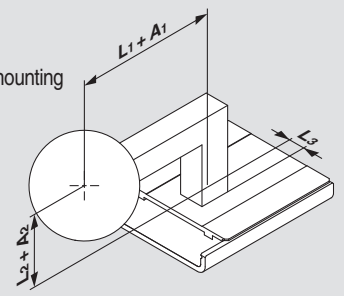
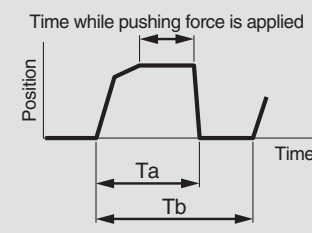
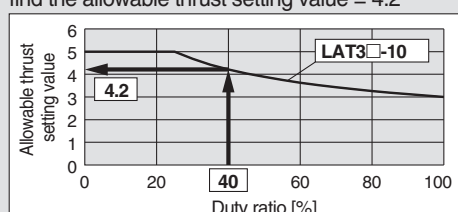
Selection Procedure	Formula/Data	Selection Example																					
<p>1 Operating conditions</p> <p>List the operating conditions with consideration to the mounting orientation and shape of the workpiece.</p> <p>*When operating the product in a vertical direction, consider the effect of the table weight on the Card Motor (See Table 2) and the weight of the workpiece to find out the pushing force of the Card Motor.</p>	<ul style="list-style-type: none"> • Stroke St [mm] • Load mass W [g] • Mounting orientation • Mounting angle θ [°] • Amount of overhang ($L1, L2, L3$) [mm] Fig.1 • Correction values for the distances to the moment center An [mm] • Measuring accuracy [μm] Fig.1 Table 1 • Positioning time Tp [ms] • Pushing force F [N] • Pushing position [mm] • Pushing direction • Positioning time + Pushing time Ta [s] • Cycle time Tb [s] 	<p>8 mm 50 g Horizontal table mounting $\theta = 0^\circ$ $L1 = 30$ mm $L2 = 10$ mm $L3 = 0$ mm 10 μm $Tp = 150$ ms 4 N 4 mm Pushing direction away from the connector 4 s 10 s</p> 																					
<p>2 Select an actuator temporarily.</p> <p>Select a model temporarily based on the required measuring accuracy and stroke.</p>	<p>Table 2</p> <table border="1"> <thead> <tr> <th>Model</th> <th>LAT3-10</th> <th>LAT3F-10</th> <th>LAT3-20</th> <th>LAT3F-20</th> <th>LAT3-30</th> <th>LAT3F-30</th> </tr> </thead> <tbody> <tr> <td>Stroke [mm]</td> <td colspan="2">10</td> <td colspan="2">20</td> <td colspan="2">30</td> </tr> <tr> <td>Measuring accuracy [μm]</td> <td>30</td> <td>1.25</td> <td>30</td> <td>1.25</td> <td>30</td> <td>1.25</td> </tr> </tbody> </table>	Model	LAT3-10	LAT3F-10	LAT3-20	LAT3F-20	LAT3-30	LAT3F-30	Stroke [mm]	10		20		30		Measuring accuracy [μm]	30	1.25	30	1.25	30	1.25	<p>From Table 2, temporarily select the LAT3F-10, which satisfies the measuring accuracy 10 μm and the minimum stroke that satisfies the stroke $St = 8$</p>
Model	LAT3-10	LAT3F-10	LAT3-20	LAT3F-20	LAT3-30	LAT3F-30																	
Stroke [mm]	10		20		30																		
Measuring accuracy [μm]	30	1.25	30	1.25	30	1.25																	
<p>3 Check the load mass and moment.</p> <p>Find the allowable load mass W_{max} [g] from the graph.</p> <p>*Confirm that the applied load mass W [g] does not exceed the allowable load mass.</p> <p>From Table 1, find the correction values for the distances to the moment center. Calculate the static moment M [N·m].</p> <p>From Table 3, find the allowable moment M_{max} [N·m]. Calculate the load factor α_n for the static moments.</p> <p>*Confirm that the total sum of the guide load factors for the static moments does not exceed 1.</p>	<p>W_{max} Fig.2</p> <p>$W \leq W_{max}$</p> <p>An Table 1</p> <p>$M = W/1000 \cdot 9.8 (Ln + An)/1000$</p> <p>$M_{max}$ Table 3</p> <p>$\alpha_x = M/M_{max}$</p> <p>$\sum \alpha_p + \alpha_y + \alpha_x \leq 1$</p>	<p>From Fig. 2: $\theta = 0$, find $W_{max} = 500$</p> <p>As $W = 50 < W_{max} = 500$, the selected model can be used.</p> <p>From Table 1, $A_1 = 22.5$</p> <p>Pitch moment $M_p = 50/1000 \times 9.8 (30 + 22.5)/1000 = 0.026$</p> <p>From Table 3, $M_{pmax} = 0.2$</p> <p>$\alpha_p = 0.026/0.2 = 0.13$</p> <p>$\sum \alpha_n = 0.13 \leq 1$, thus, the selected model can be used.</p>																					
<p>4 Check the positioning time.</p> <p>Find the shortest positioning time T_{min} [ms] from the graph.</p> <p>* Confirm that the positioning time Tp [ms] is longer than the minimum positioning time.</p>	<p>T_{min} Fig.3</p> <p>$Tp \geq T_{min}$</p>	<p>From Fig. 3: $St = 8$ and $W = 50$, find $T_{min} = 100$</p> <p>As $Tp = 150 \geq T_{min} = 100$, the selected model can be used.</p>																					
<p>5 Check the pushing force.</p> <p>Calculate the duty ratio [%].</p> <p>Find the allowable thrust setting value from the graph.</p> <p>From Fig. 5, find the allowable pushing force F_{max} [N] generated at the required pushing position and for the allowable thrust setting value.</p> <p>Confirm that the pushing force F [N] does not exceed the allowable pushing force.</p>	<p>Duty ratio = $Ta/Tb \times 100$ Fig.4</p> <p>$F \leq F_{max}$</p> 	<p>Duty ratio = $4/10 \times 100 = 40\%$</p> <p>From Fig. 4: LAT3□-10 and 40% duty ratio, find the allowable thrust setting value = 4.2</p>  <p>From Fig. 5: LAT3□-10, pushing direction away from the connector at pushing position 4 mm, find $F_{max} = 4.5$</p> <p>As $F = 4 \leq F_{max} = 4.5$, the selected model can be used.</p>																					

Series LAT3 Model Selection 2

Selection

⚠ Caution

1. The temperature increase of the Card Motor varies depending on the duty ratio and the heat dissipation properties of the base it is mounted onto. If the temperature of the Card Motor becomes high, reduce the duty ratio by increasing the cycle time, or improve the heat transfer properties of the mounting base and the surroundings.
2. The pushing force generated by the Card Motor varies in relation to the thrust setting value depending on the pushing position and the pushing direction. Refer to Fig. 5 for details.

Fig. 1 Amount of Overhang: L_n [mm], Correction Value for the Distances to the Moment Center: A_n [mm]

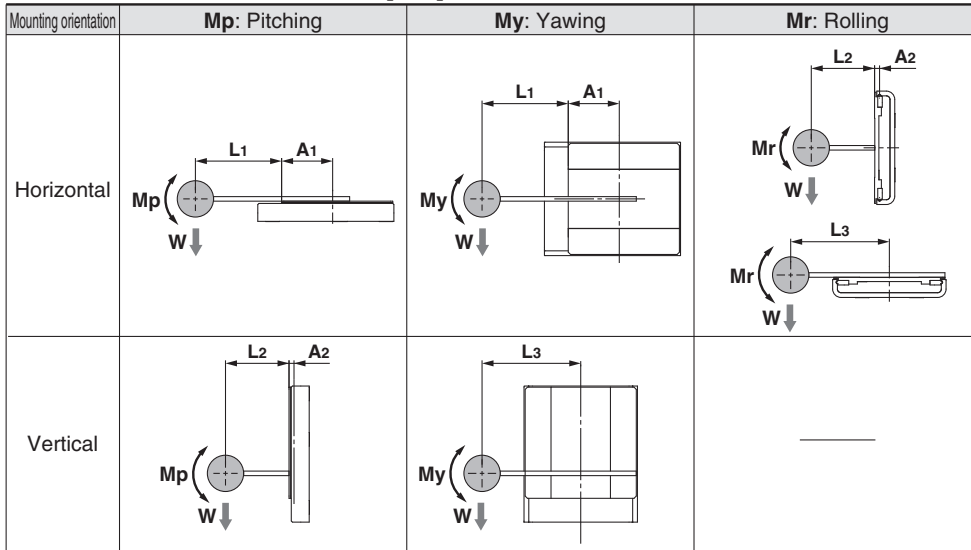

Table 1 Correction Value for the Distances to the Moment Center: A_n [mm]

Model	A_1	A_2
LAT3□-10	22.5	2.2
LAT3□-20	32.5	2.2
LAT3□-30	42.5	2.2

Fig. 2 Allowable Load Mass: W_{max} [g]

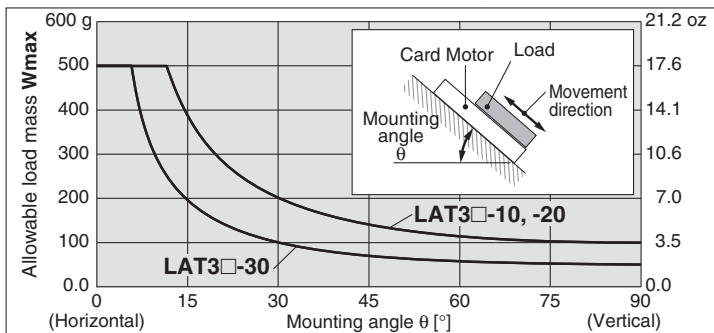
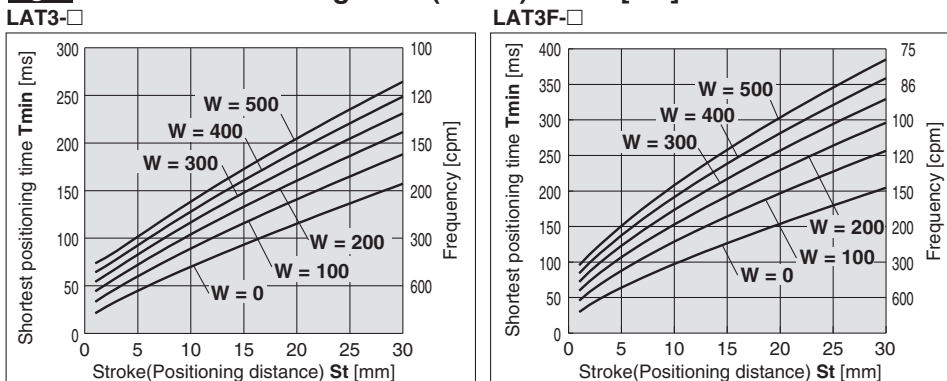

Fig. 3 Shortest Positioning Time (Guide): T_{min} [ms]



Operating condition Model: LAT3-□
Mounting orientation: Horizontal/Vertical
Step data input version: Takt time entry method (Triangular drive)

Operating condition Model: LAT3F-□
Mounting orientation: Horizontal/Vertical
Step data input version: Takt time entry method (Triangular drive)

Fig. 4 Allowable Thrust Setting Value

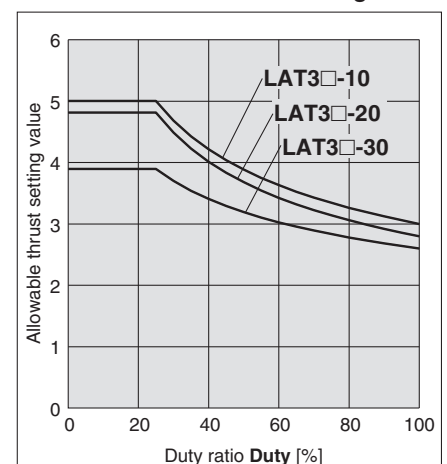
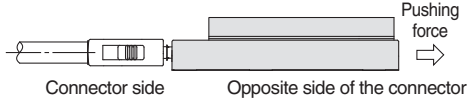

Fig.5 Pushing force: F [N] characteristics (Reference)

Pushing direction away from the connector



Operating condition

Mounting orientation: Horizontal table mounting
Thrust setting value: Minimum, continuous, instantaneous maximum of each model.

Table start position: Retracted end (Connector side)

Pushing direction: Away from the connector
Pushing position: Positioning distance from the connector side, retracted end

LAT3□-10

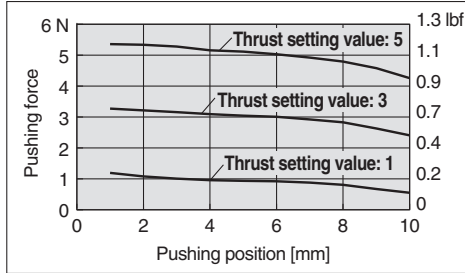

LAT3□-20

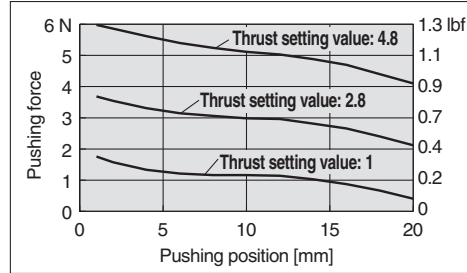

LAT3□-30

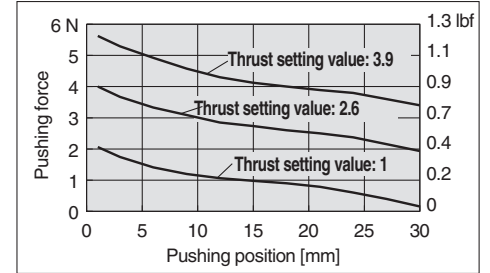

Pushing direction toward the connector

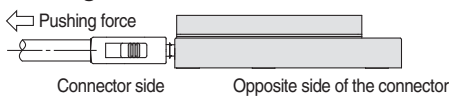

Operating condition

Mounting orientation: Horizontal table mounting
Thrust setting value: Minimum, continuous, instantaneous maximum of each model.

Table start position: Extended end (Opposite side of the connector)

Pushing force direction: Toward the connector
Pushing position: Positioning distance from the connector side, retracted end

LAT3□-10

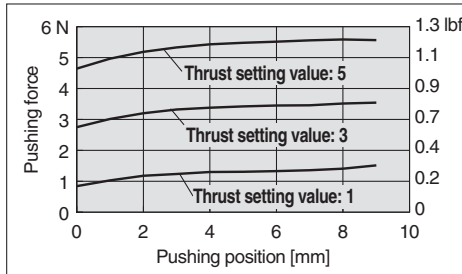

LAT3□-20

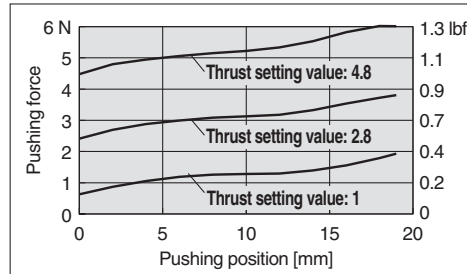

LAT3□-30

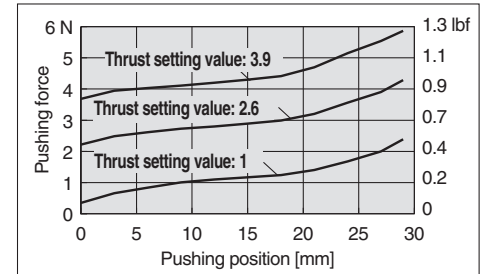
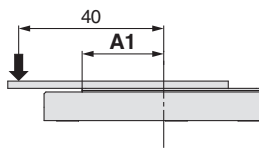

Table Displacement (Reference Values)

Displacement through the entire stroke when a load is applied to the point indicated by the arrow

Table displacement due to pitch moment load



LAT3□-10, -20, -30

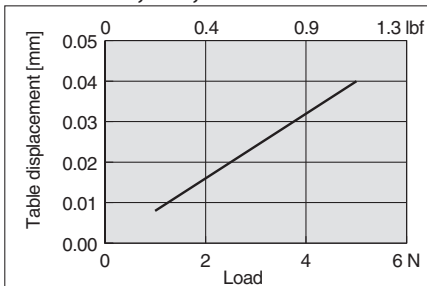
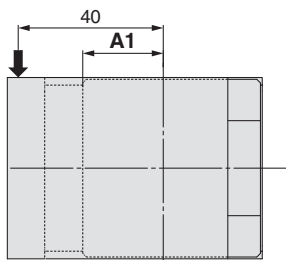

Table displacement due to yaw moment load



LAT3□-10, -20, -30

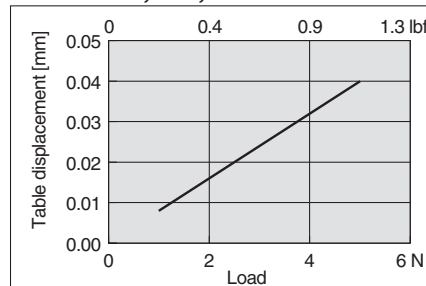
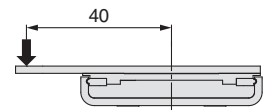

Table displacement due to roll moment load



LAT3□-10, -20, -30

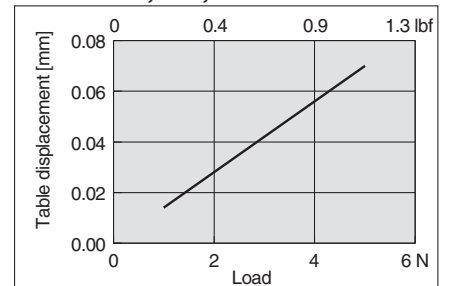

Table 2 Stroke: St [mm], Positioning Repeatability [μm], Measuring Accuracy [μm], Table Weight [g]

Model	LAT3-10	LAT3F-10	LAT3-20	LAT3F-20	LAT3-30	LAT3F-30
Stroke [mm]	10		20		30	
Positioning repeatability [μm]	±90	±5	±90	±5	±90	±5
Measuring accuracy [μm]	30	1.25	30	1.25	30	1.25
Table weight oz [g]	1.8 (50)		2.5 (70)		3.2 (90)	

Table 3 Allowable Moment: Mmax

Model	Pitch moment/Yaw moment Mpmax, Mymax	Roll moment Mrmax
LAT3□-10	0.15 lbf-ft (0.2 N-m)	0.15 lbf-ft (0.2 N-m)
LAT3□-20	0.22 lbf-ft (0.3 N-m)	0.15 lbf-ft (0.2 N-m)
LAT3□-30	0.30 lbf-ft (0.4 N-m)	0.15 lbf-ft (0.2 N-m)

Card Motor Series LAT3



How to Order

LAT3 - 10 - 1 N 1 D

Sensor resolution

Nil	30 μm
F	1.25 μm

Stroke

10	10 mm
20	20 mm
30	30 mm

Actuator cable length

Nil	Without cable
1	1 m
3	3 m
5	5 m

Controller mounting

Nil	Screw mounting
D ^{Note 3)}	DIN rail mounting

I/O cable length^{Note 2)}

Nil	Without cable
1	1 m
3	3 m
5	5 m

Controller^{Note 1)}

Nil	Without controller
N	With controller (NPN)
P	With controller (PNP)

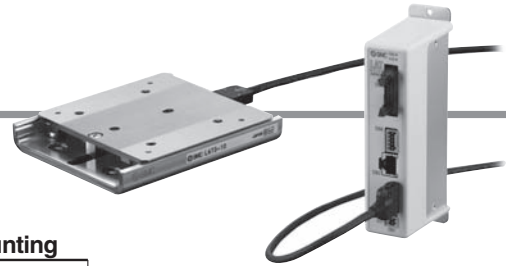

Note 1) Refer to page 3 for detailed specifications of the controller.

Note 2) If "Without controller" has been selected, the I/O cable is also not included.

Therefore it is not possible to select the I/O cable for this option.

If the I/O cable is required, please order separately. (Refer to page 11, "[I/O cable]" for details.)

Note 3) The DIN rail is not included. If the DIN rail is required, please order separately. (Refer to page 4, "DIN rail" and "DIN rail mounting adapter" for details.)

System Construction

Separately sold products^{Note 2)}

- Multi-counter^{Note 5)}
- Counter cable



Accessories

- Counter plug

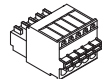

- Power supply plug

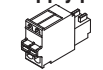

Controller type^{Note 1)}



Option^{Note 1)}

- I/O cable



Separately sold products^{Note 2)}

- Controller setup kit^{Note 4)}
Controller setup software



Option^{Note 1)}

- Actuator cable



Provided by customer^{Note 3)}

- PLC

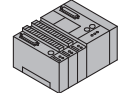

- PC

Provided by customer^{Note 3)}

- Controller power supply 24 VDC
- Power supply cable (AWG20, 0.5 mm²)



Options (Can be ordered separately or with the motor part number)

No.	Description	Part no.	Remarks
1	Controller	LATC4-□□□□	For details, refer to page 3.
2	Actuator cable	LATH1-□	For details, refer to page 11.
3	I/O cable	LATH2-□	For details, refer to page 11.

Accessories (Supplied with the controller attached to it)

No.	Description	Remarks
1	Power supply plug	For the controller power supply
2	Counter plug	For the multi-counter

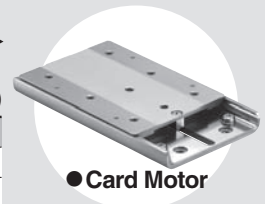

Separately Sold Products

No.	Description	Part no.	Remarks
1	Multi-counter	CEU5□□□□	For details, refer to page 12.
2	Counter cable	LATH3-□	For details, refer to page 11.
3	Controller setup kit	LATC-W1	For details, refer to page 12.

Note 1) It is possible to include options such as controllers and cables in the "How to Order" for the Card Motor. Refer to "How to Order" on this page for details.

Note 2) It is not possible to include separately sold products in the "How to Order" for the Card Motor. Refer to pages 11 and 12, and order separately.

Note 3) Power supply, power supply cables, PLC and PCs should be prepared by the user.

Note 4) These items are used to set the actuator parameters and the operating conditions to the controller and to perform test operations.

Note 5) These items are used to display the table position and to signal active pre-set positions to external devices via digital outputs when measuring the length.

Specifications

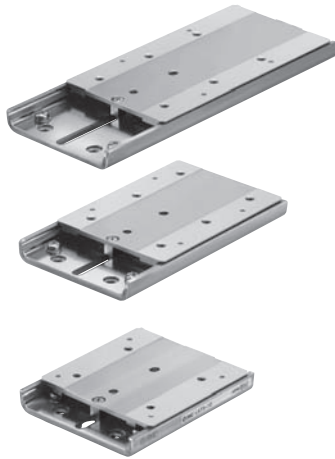

Model		LAT3-10	LAT3F-10	LAT3-20	LAT3F-20	LAT3-30	LAT3F-30
Stroke (mm)		10		20		30	
Motor	Type	Moving magnetic type linear motor					
	Instantaneous max. thrust ^{Note 1)2)3)}	1.17 lbf (5.2 N)		1.35 lbf (6 N)		1.23 lbf (5.5 N)	
	Continuous thrust ^{Note 1) 2) 3)}	0.7 lbf (3 N)		0.63 lbf (2.8 N)		0.58 lbf (2.6)	
Guide	Type	Linear guide with circulating balls					
	Maximum load mass oz (g)	Horizontal: 17.6 (500), Vertical: 3.5 (100)				Horizontal: 17.6 (500) Vertical: 1.8 (50)	
Sensor	Type	Optical linear encoder (incremental)					
	Resolution (μm)	30	1.25	30	1.25	30	1.25
	Home position signal	None	Provided	None	Provided	None	Provided
Pushing operation	Pushing speed (mm/s)	6					
	Thrust setting value ^{Note 1)2)3)}	1 to 5		1 to 4.8		1 to 3.9	
Positioning operation	Positioning repeatability (μm) ^{Note 4)5)}	±90	±5	±90	±5	±90	±5
	Accuracy (μm) ^{Note 4)5)}	±100	±10	±100	±10	±100	±10
Maximum speed (mm/s) ^{Note 6)}		400					
Operating temperature range		41 to 104°F (5 to 40°C) (No condensation)					
Operating humidity range (%)		35 to 85 (No condensation)					
Weight oz (g) ^{Note 7)}		4.6 (130)		6.7 (190)		8.8 (250)	
Table weight oz (g)		1.8 (50)		2.5 (70)		3.2 (90)	

Note 1) Continuous thrust can be generated and maintained continuously. Instantaneous maximum thrust can be generated. Refer to **Fig. 4** Allowable thrust setting value (Front matter 3) and to **Fig. 5** Pushing force characteristics (Front matter 4).

Note 2) When mounted on a heat dissipating base at an ambient temperature of 68°F (20°C).

Note 3) The pushing force varies depending on the operating environment, pushing direction and table position. Refer to **Fig. 5** Pushing force characteristics (Front matter 4).

Note 4) When the temperature of the Card Motor is 68°F (20°C).

Note 5) The accuracy after mounting the Card Motor may vary depending on the mounting conditions, operating conditions and environment, so please calibrate it with the equipment used in your application.

Note 6) The maximum speed varies depending on the operating conditions (load mass, positioning distance).

Note 7) The weight of the Card Motor itself. Controllers and cables are not included.

Dimensions

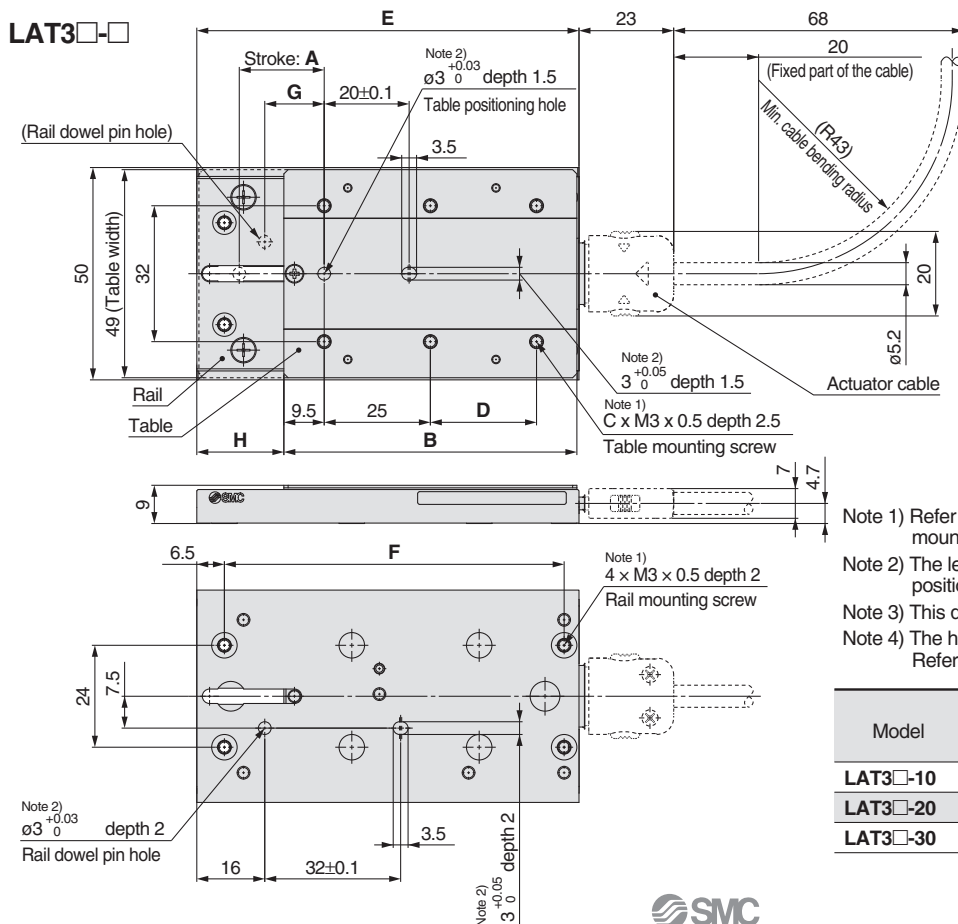

Note 1) Refer to page 14 regarding Specific Product Precautions for the mounting screws.

Note 2) The length of the part of the dowel pin inserted into the positioning hole should be shorter than the specified depth.

Note 3) This drawing shows the home position.

Note 4) The home positions G and H are reference dimensions (guide). Refer to page 9 for details on the home position.

Model	Stroke	Table dimensions				Rail dimensions		Home position ^{Note 4)}	
		A	B	C	D	E	F	G	H
LAT3□-10	10	49	4	—	60	50	4	10.5	
LAT3□-20	20	69	6	25	90	80	14	20.5	
LAT3□-30	30	89	6	25	120	110	24	30.5	

Card Motor Controller

Series LATC4



How to Order

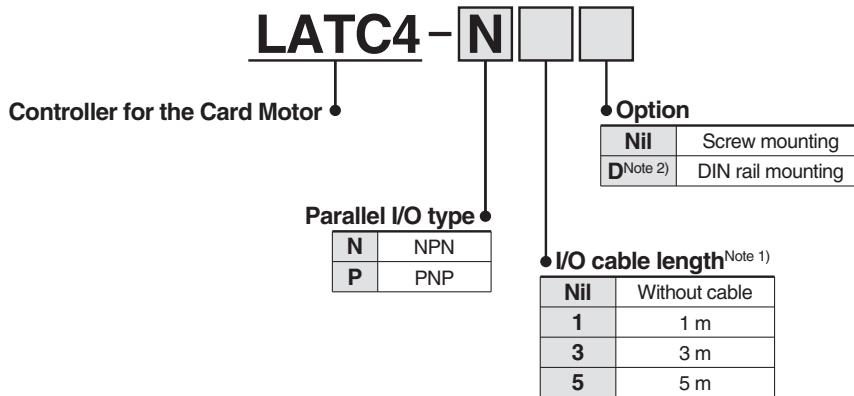

Note 1) The actuator cable, the counter cable and the controller setting cable are not supplied with the controller. Refer to pages 11 and 12 for options.

Note 2) The DIN rail is not included. If the DIN rail is required, please order separately. (Refer to page 4.)

Specifications

Item	Specifications
Power supply ^{Note 1)}	Power supply voltage: 24 VDC $\pm 10\%$, Current consumption: Rated 2 A (Peak 3 A) ^{Note 2)} Power consumption: 48 W (Maximum 72 W) ^{Note 2)}
Parallel input	6 inputs (Optically isolated)
Parallel output	4 outputs (Optically isolated, open collector output)
Step data	15 points
Position display output ^{Note 3)}	A-phase and B-phase pulse signals, RESET signal (NPN open collector output)
LED indicator	2 LED's (Green and Red)
Cooling method	Natural air-cooling
Operating temperature range	41 to 104°F (5 to 40°C) (No condensation)
Operating humidity range	35 to 85% (No condensation)
Insulation resistance	Between case and FG: 50 MΩ (500 VDC)
Weight ^{Note 4)}	Screw mounting: 4.6 oz (130 g), DIN rail mounting: 5.3 oz (150 g)

Note 1) Do not use a power supply of "inrush current limited" type for the controller.

Note 2) Rated current: Current consumption when continuous thrust is generated. Peak current: Current consumption when maximum instantaneous thrust is generated.

Note 3) Specification for the connection of the separately sold multi-counter (CEU5).

Note 4) Cables are not included.

How to Mount

a) Screw mounting (LATC4-□□)
(Installation with two M4 screws)

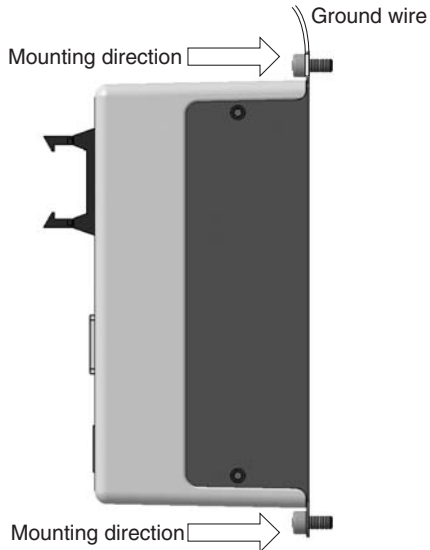

b) DIN rail mounting (LATC4-□□□)
(Installation with the DIN rail)

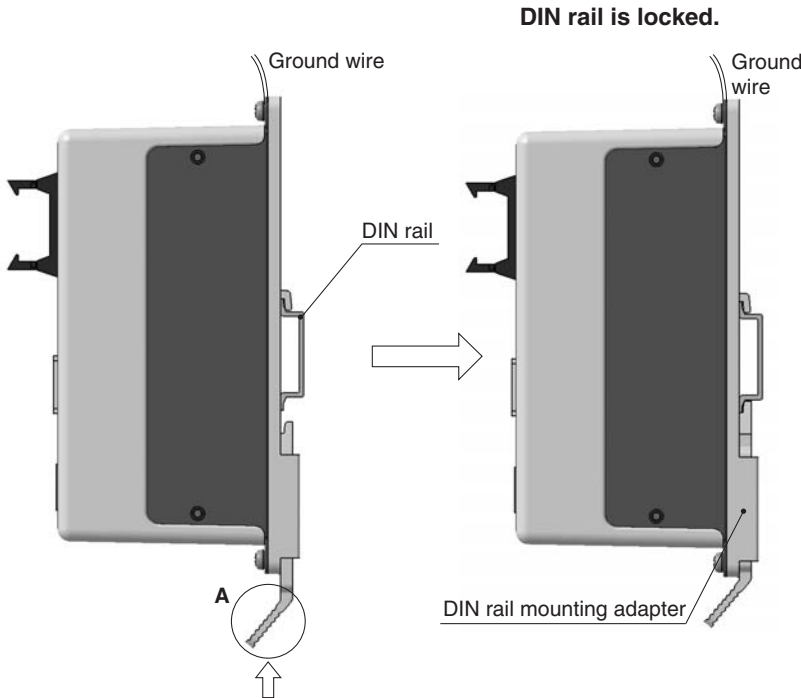

Hook the controller on the DIN rail and press the lever of section **A** in the arrow direction to lock it.

DIN rail
AXT100-DR-□

*For □, enter a number from the "No." line in the table below. Refer to the dimensions on page 5 for the mounting dimensions.

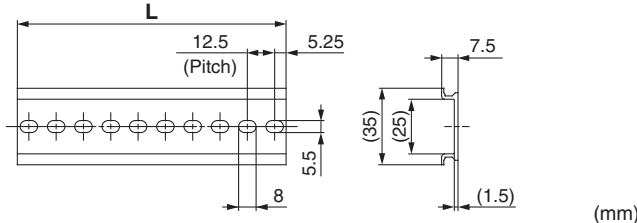

L Dimensions

No.	1	2	3	4	5	6	7	8	9	10	11	12	13	14	15	16	17	18	19	20
L dimension	23	35.5	48	60.5	73	85.5	98	110.5	123	135.5	148	160.5	173	185.5	198	210.5	223	235.5	248	260.5
No.	21	22	23	24	25	26	27	28	29	30	31	32	33	34	35	36	37	38	39	40
L dimension	273	285.5	298	310.5	323	335.5	348	360.5	373	385.5	398	410.5	423	435.5	448	460.5	473	485.5	498	510.5

DIN rail mounting adapter
LEC-D0 (with 2 mounting screws)

The DIN rail mounting adapter can be retrofitted onto a screw mounting type controller.

Series LATC4

Dimensions

(mm)

a) Screw mounting (LATC4-□□)

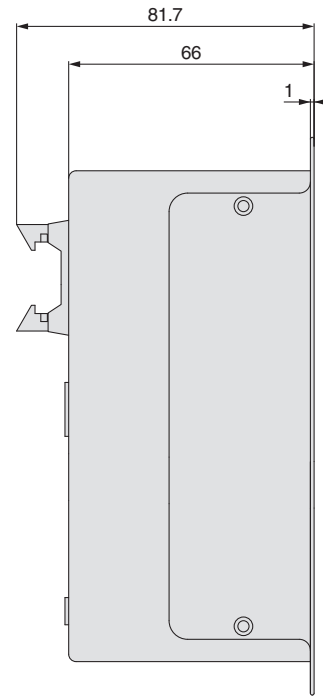
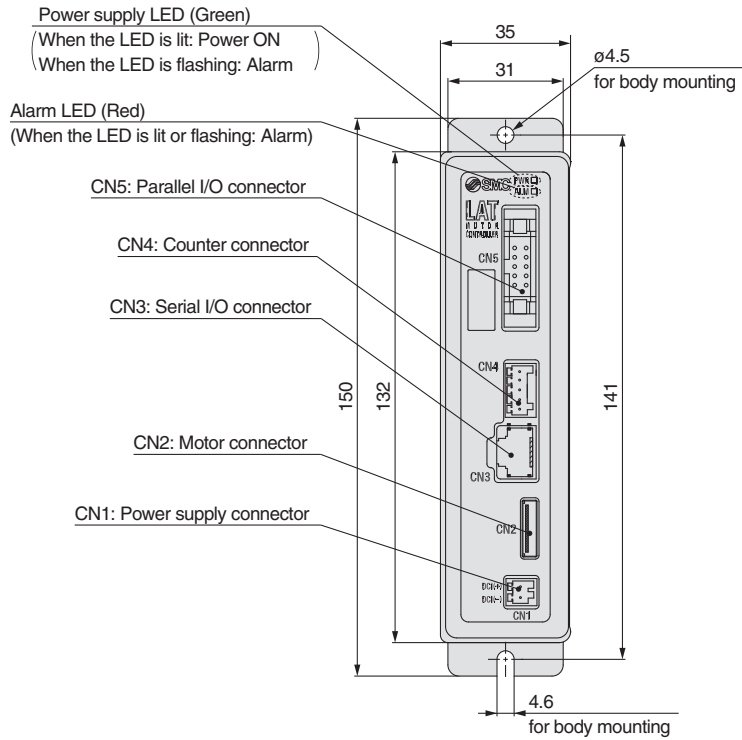

b) DIN rail mounting (LATC4-□□D)

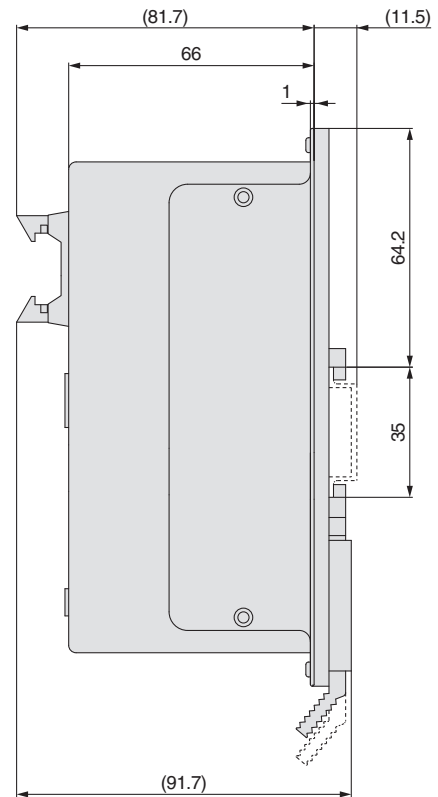
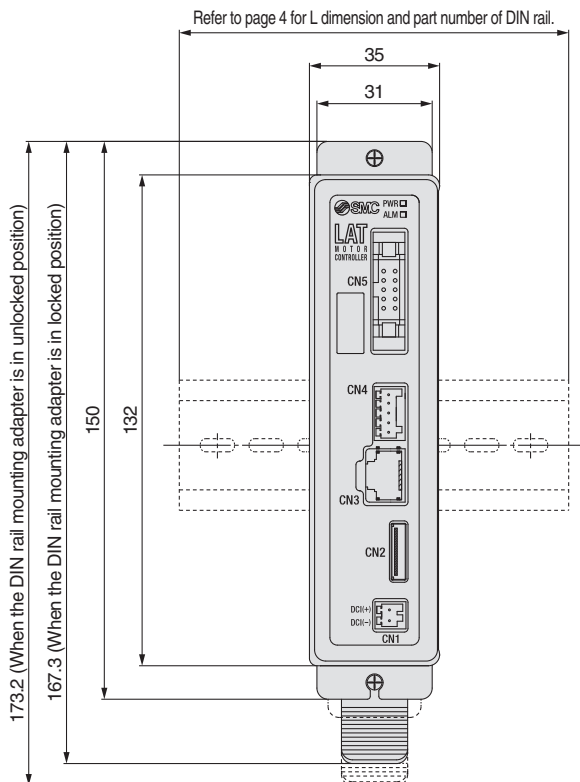

Note) When two or more controllers are used, keep the interval between them 10 mm or more.

Wiring Example

Power Supply Connector: CN1

* The power supply plug is an accessory (supplied with the controller).
Use an AWG20 (0.5 mm²) cable for connecting the power supply plug to a 24 VDC power supply.

Power Supply Connector Terminal

Terminal name	Function	Details
DC1 (-)	Power supply (-)	The negative (-) power supply terminal to the controller. Power (-) is also supplied to the Card Motor via the internal circuit of the controller and actuator cable.
DC1 (+)	Power supply (+)	The positive (+) power supply terminal to the controller. Power (+) is also supplied to the Card Motor via the internal circuit of the controller and actuator cable.

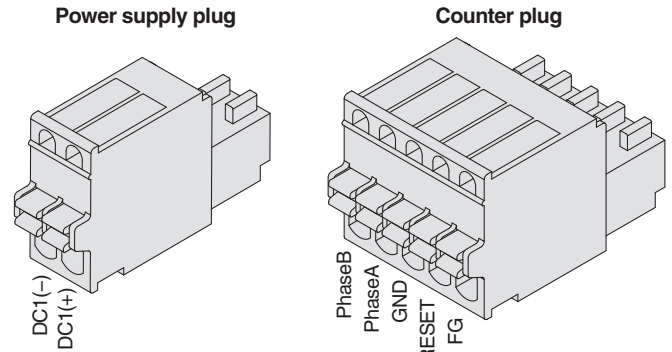

Counter Connector: CN4

* The counter plug is an accessory (supplied with the controller).
* Use the counter cable (LATH3-□) for connecting the counter to the counter plug.

Counter Connector Terminal

Name	Details	Cable color
PhaseB	Connect to the phase B wire of the counter cable.	White
PhaseA	Connect to the phase A wire of the counter cable.	Red
GND	Connect to the GND wire of the counter cable.	Light gray
RESET	Connect to the Reset wire of the counter cable.	Yellow
FG	Connect to the FG wire of the counter cable.	Green

Parallel I/O Connector: CN5

* Use the I/O cable (LATH2-□) to connect a PLC, etc., to the CN5 parallel I/O connector.
* The wiring is specific to the type of parallel I/O (NPN or PNP). Please refer to the wiring diagrams below for correct wiring of NPN and PNP type controllers.

■ NPN output circuit

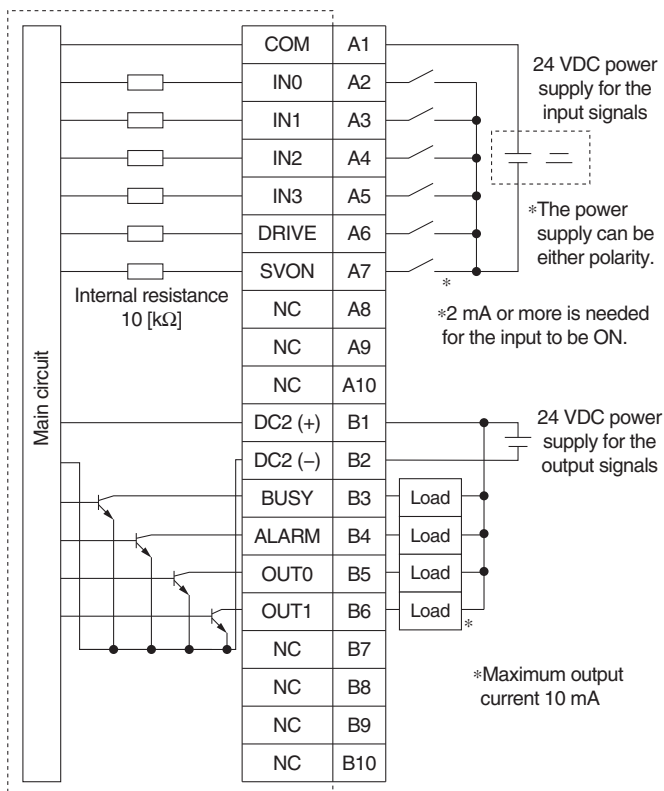

■ PNP output circuit

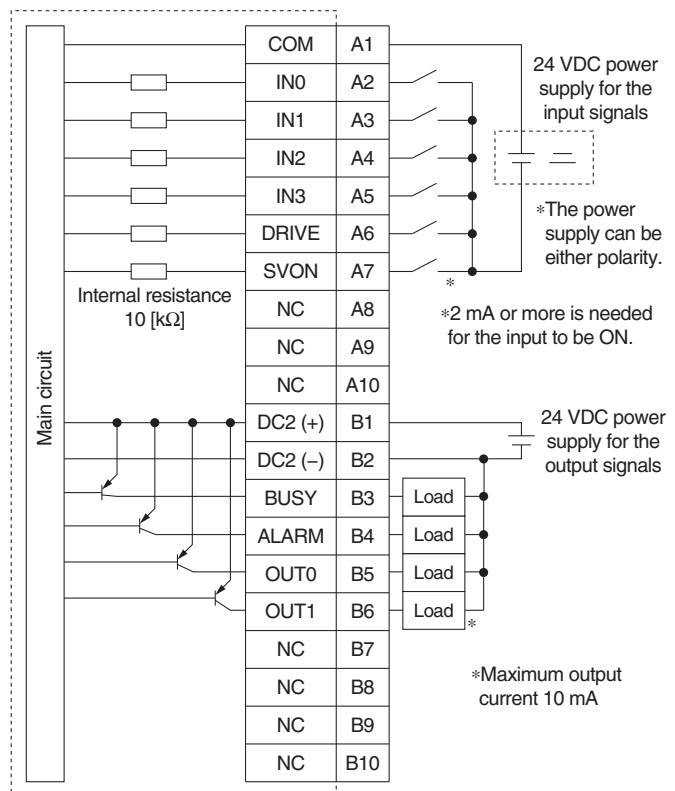

Input Signal

Name	Details
COM	Connect a 24 VDC power supply for the input signals. (Polarity is reversible)
IN0 to IN3	Selection of step data number specified by a Bit No. (combinations of IN0 to IN3)
DRIVE	Command to drive the motor
SVON	Command to turn the servo motor ON
NC	Not connected

Output Signal

Name	Details
DC2 (+)	Connect the 24 V power supply terminal for the output signals.
DC2 (-)	Connect the 0 V power supply terminal for the output signals.
BUSY	ON when the actuator is moving
ALARM	OFF when an alarm has been generated ^{Note 1)}
OUT0 to OUT1	OUT0: Default output for the INP (in position) signal, OUT1: Currently not used. ^{Note 2)}
NC	Not connected

Note 1) This output signal is ON when power is supplied to the controller, and OFF when an alarm is generated.
Note 2) The INP signal (OUT0) is turned ON when the actuator comes close to the target position.

Series LATC4

Step Data Setting Methods and Movement Profiles

There are two methods for setting the step data in the Card Motor controller as described below.

Takt time entry method

To operate the table based on the position and the positioning time or to operate it at high frequency. After the required position and positioning time have been set, the speed, acceleration and deceleration are calculated automatically.

Speed entry method

To operate the table at a constant speed. The table moves to the set position based on the set speed, acceleration and deceleration.

Takt Time Entry Method (Positioning Operation)

Setting items: **Target position [mm]** **Positioning time [s]** **Load mass [g]**

Calculate the positioning distance S [mm] between the start position and the target position. The table will move to the target position according to a triangular movement profile shown in the diagram on the right based on the set positioning time t_p [s].

The positioning time should be set larger than the shortest positioning time shown in Fig. 3 in Front matter 3 with consideration to the load mass during the operation. If there is overshoot or vibration, set the positioning time longer.

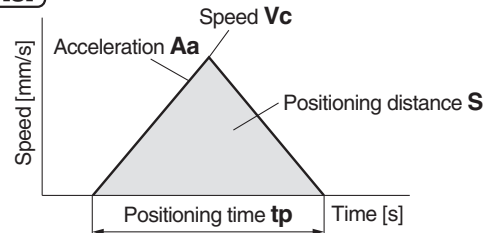

Speed Entry Method (Positioning Operation)

Setting items: **Target position [mm]** **Speed [mm/s]** **Acceleration [mm/s²]** **Deceleration [mm/s²]** **Load mass [g]**

Calculate the positioning distance S [mm] between the start position and the target position. The table will move to the target position according to a trapezoidal movement profile shown in the diagram on the right based on the set speed V_c [mm/s], acceleration A_a [mm/s²] and deceleration A_d [mm/s²].

For how to calculate the acceleration time, time with constant velocity, deceleration time, and distance, refer to the equations below.

Acceleration time: $t_a = V_c / A_a$ [s]

Deceleration time: $t_d = V_c / A_d$ [s]

Acceleration distance: $S_a = 0.5 \times A_a \times t_a^2$ [mm]

Deceleration distance: $S_d = 0.5 \times A_d \times t_d^2$ [mm]

Distance with constant velocity: $S_c = S - S_a - S_d$ [mm]

Time with constant velocity: $t_c = S_c / V_c$ [s]

Positioning time: $t_p = t_a + t_c + t_d$ [s]

(Add settling time to the positioning time to get the takt time.)

*The settling time varies depending on the positioning distance and load mass. 0.15 seconds can be used as a reference value.

The acceleration and deceleration should be smaller than the maximum acceleration/deceleration with consideration to the load mass during the operation as specified in the diagram on the right.

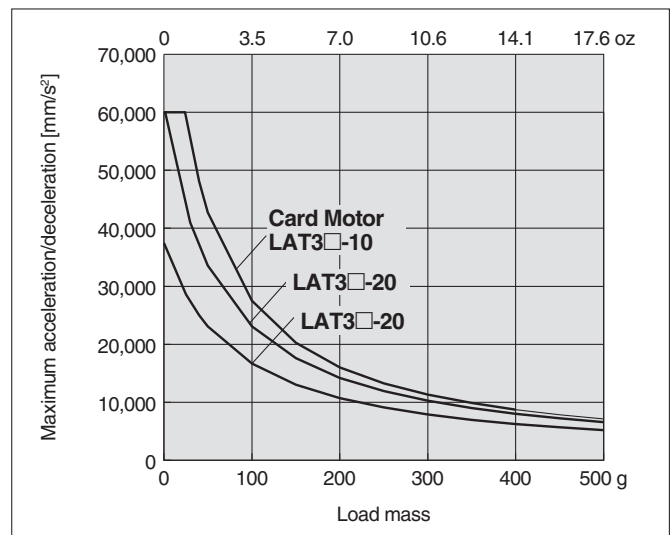
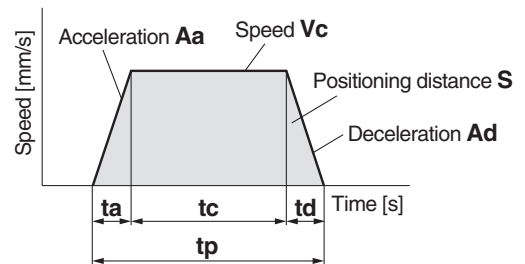

⚠ Caution

If the acceleration/deceleration is low, the table may not reach the set speed due to a triangular movement profile.

Operation Modes

The Card Motor controller has two operation modes as described below.

Position For transporting a workpiece to a specific position

Pushing For applying force to a workpiece

Positioning Operation

Takt Time Entry Method: The acceleration and deceleration are automatically calculated by the set positioning time, and the table moves according to a triangular movement profile ① and stops at the target position ②.

Speed Entry Method: The table moves based on the set acceleration, speed and deceleration according to a trapezoidal movement profile ① and stops at the target position ②.

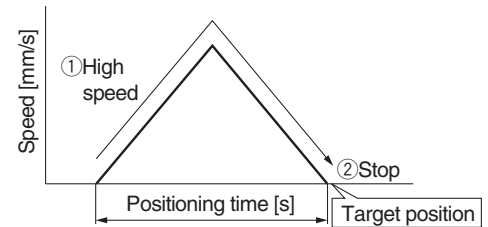
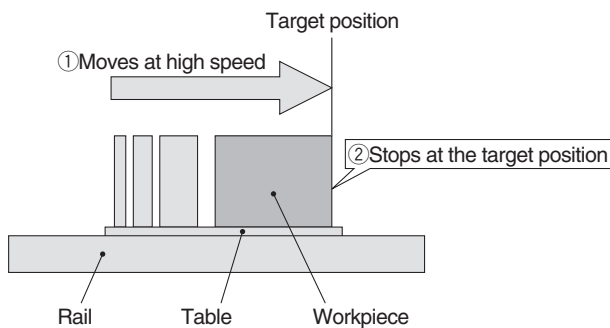

Movement profile for the Takt Time Entry Method (Triangular)

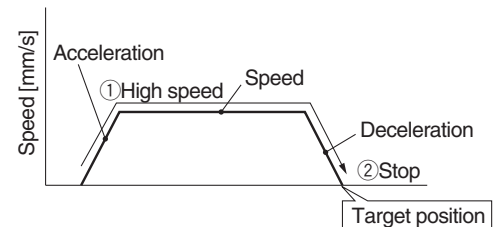

Movement profile for the Speed Entry Method (Trapezoidal)

Pushing Operation

Takt Time Entry Method: The acceleration and deceleration are automatically calculated by the set positioning time, and the table moves according to a triangular movement profile to the target position ①, decelerates and continues to move at low speed (6 mm/s) until it comes into contact with the workpiece ②. After the table has come into contact with the workpiece, the Card Motor presses the workpiece ③.

Speed Entry Method: The table moves based on the set acceleration, speed and deceleration according to a trapezoidal movement profile to the target position ①, decelerates and continues to move at low speed (6 mm/s) until it comes into contact with the workpiece ②. After the table has come into contact with the workpiece, the Card Motor presses the workpiece ③.

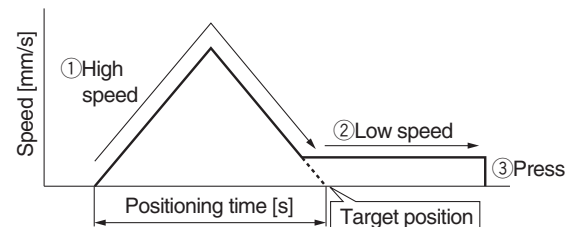
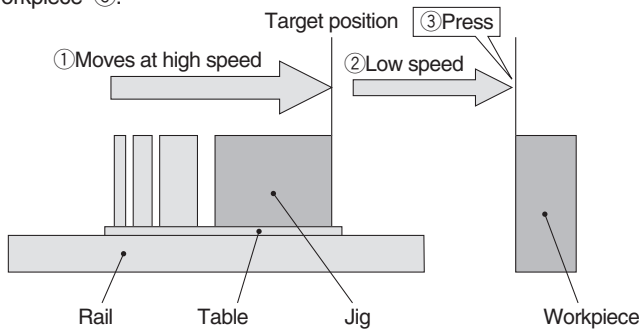

Movement profile for the Takt Time Entry Method (Triangular)

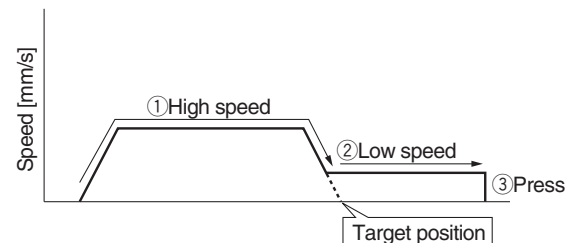

Movement profile for the Speed Entry Method (Trapezoidal)

⚠ Caution

For pushing operations, set the target position at least 1 mm away from the position where the table or the pushing tool comes into contact with the workpiece. Otherwise, the table may hit the workpiece at a speed exceeding the specified 6 mm/s pushing speed, which could damage the workpiece and Card Motor.

The pushing force varies from the thrust setting value depending on the operating environment, pushing direction and table position. The thrust setting value is a nominal value. Please calibrate the thrust setting value according to the application requirements.

Series LATC4

Return to Home Position

The Card Motor uses an incremental type sensor (linear encoder) to detect the position of the table. Therefore it is necessary to return the table to the home position after the power has been turned on.

There are three [Return to Home Position] methods as stated below.

In any of the methods, the home position (0) will be set at the connector side. When the table is moved away from the connector toward the opposite side, after the [Return to Home Position] has been performed, the new position of the table is added in the controller (incremental positive direction).

① Retracted end position (Connector side)

The default home position is set to the connector side [Retracted End Position]. The table is moved toward the connector side, returns 0.3 mm and the home position (0) is set at 0.3 mm away from the mechanical end stop of the table at the connector side. After [Return to Home Position] is completed, the table stops at the home position.

② Extended end position

An external jig is used to stop the table of the Card Motor when the [Return to Home Position] is performed. The table is moved to the opposite side of the connector, returns 0.3 mm and the home position is set at 0.3 mm away from the mechanical end stop of the table at the opposite side of the connector. After [Return to Home Position] is completed, the table stops at the maximum stroke end (A).

③ Sensor home

This method is used to achieve high positioning repeatability accuracy of the home position. Only the LAT3F-□, which is equipped with a home position signal (Z-pulse) in the sensor, can be used with this method. The home position is set based on the Z-pulse from the integrated sensor (linear encoder). The table is moved to the Z-pulse of the integrated sensor, and the home position of the table is set at a certain distance (J) away from the Z-pulse when the [Return to Home Position] is performed. After [Return to Home Position] is completed, the table stops at the sensor home signal position.

If the table is returned to the home position by the mechanical end stopper installed in the Card Motor, the home position will be set to the position shown below.

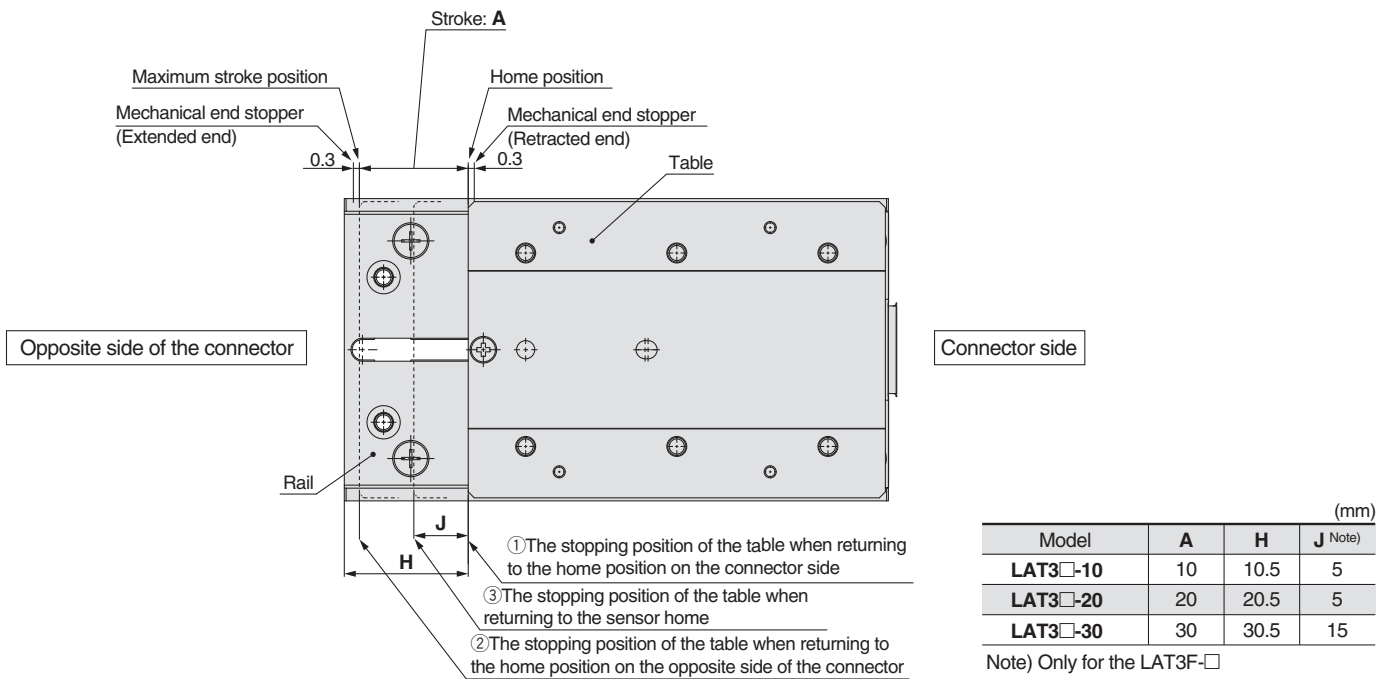

⚠ Caution

- The home position varies depending on the return to home position method. Please adjust according to the specific equipment used with this product.
- If the return to home position is performed using an external jig or workpiece to stop the table, the home position may be set outside of the travel range. Do not set the target position of the step data outside of the Card Motor movable range. It may damage the workpieces and the Card Motor.

Signal Timing

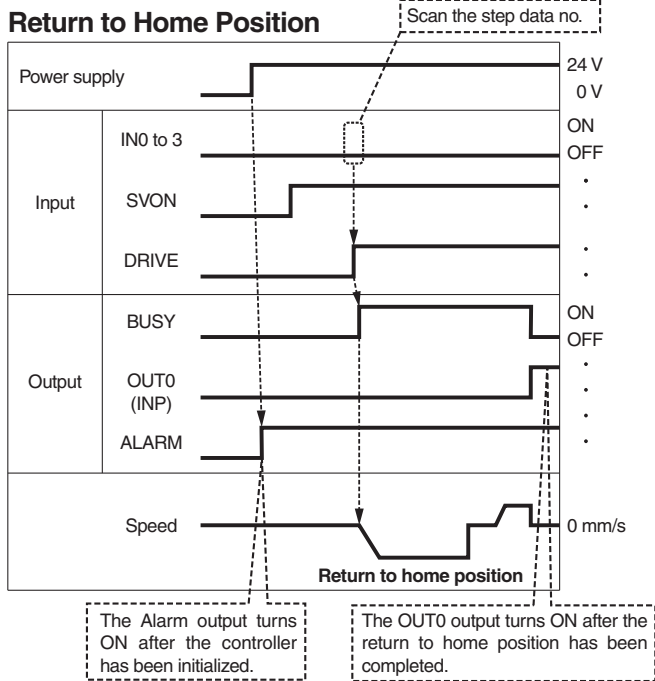

* "ALARM" is expressed as negative-logic circuit.

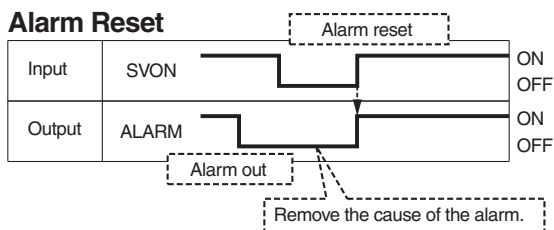
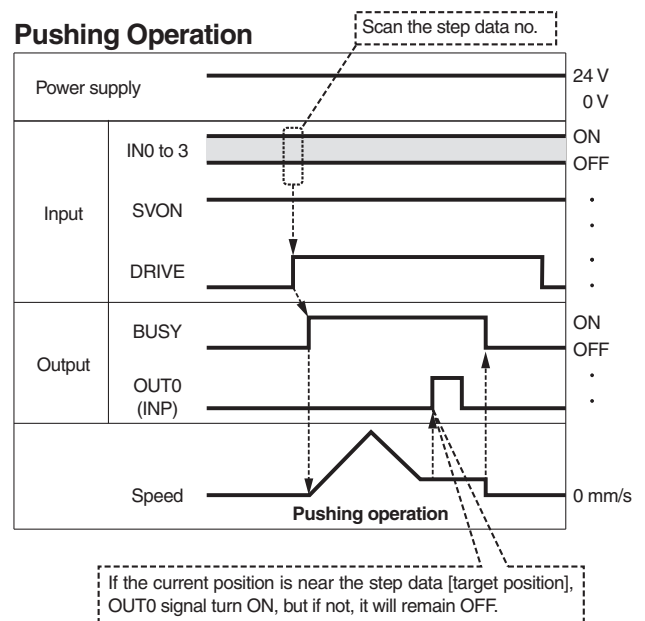
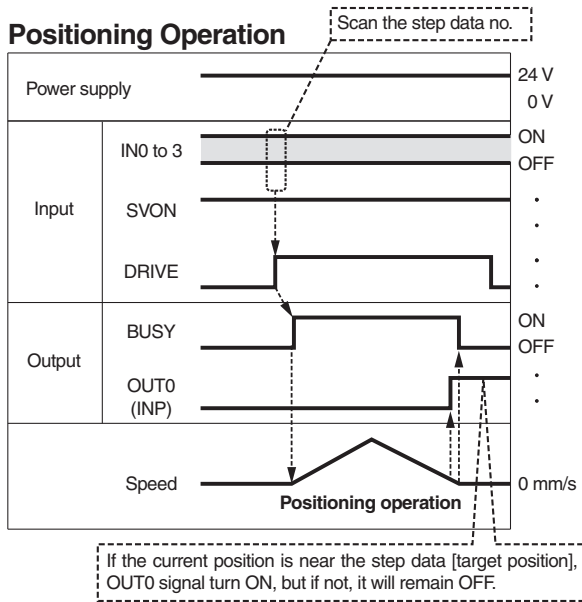

* "ALARM" is expressed as negative-logic circuit.

⚠ Caution
Please ensure an interval 2 msec or more between input signals, and maintain the signal state for at least 2 msec.

Series LATC4

Options

[Actuator cable]

LATH1 - 1

Cable length (L)

1	1 m
3	3 m
5	5 m

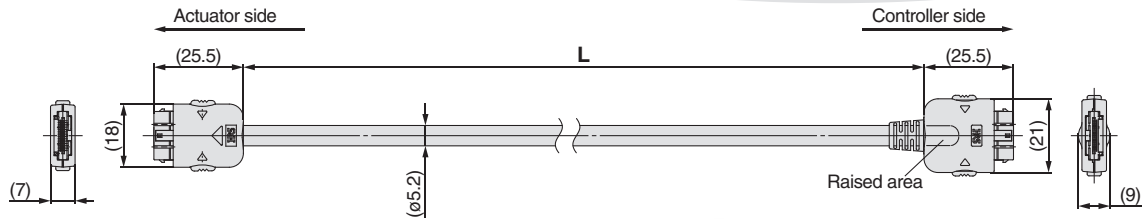

Note) The actuator cable is direction dependent.
Make sure to connect the Card Motor side of the cable to the Card Motor and vice versa. There is a small raised area on the connector for the controller.

[I/O cable]

LATH2 - 1

Cable length (L)

1	1 m
3	3 m
5	5 m

* Conductor size: AWG28

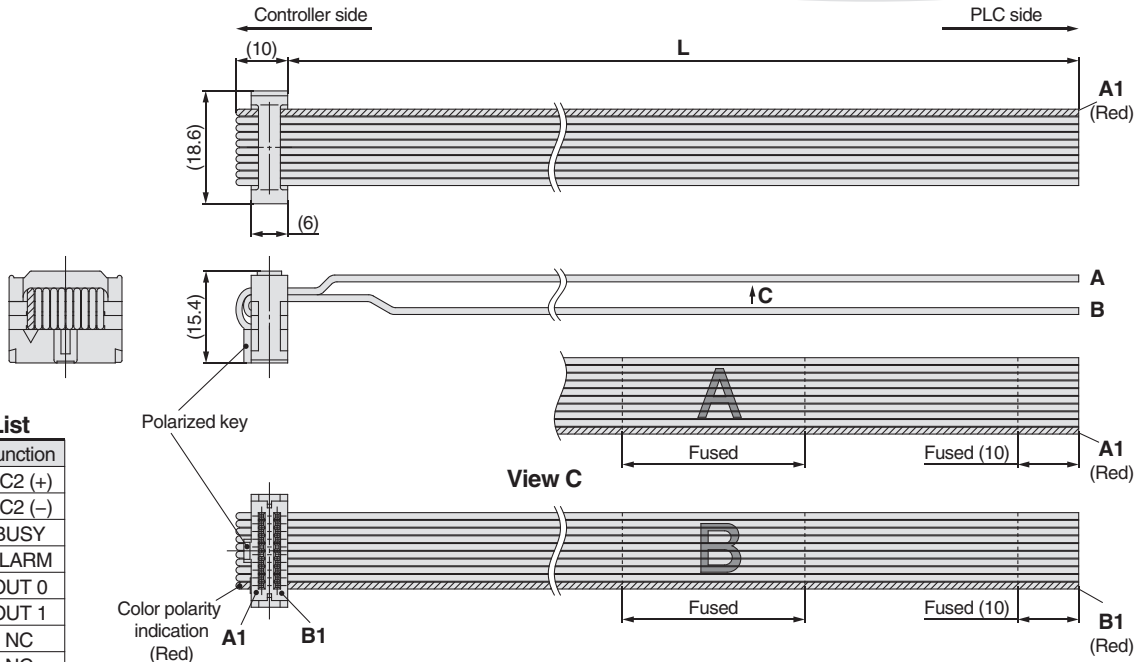

Parallel I/O Plug Terminal List

Terminal no.	Function	Terminal no.	Function
A1	COM	B1	DC2 (+)
A2	IN 0	B2	DC2 (-)
A3	IN 1	B3	BUSY
A4	IN 2	B4	ALARM
A5	IN 3	B5	OUT 0
A6	DRIVE	B6	OUT 1
A7	SVON	B7	NC
A8	NC	B8	NC
A9	NC	B9	NC
A10	NC	B10	NC

[Counter cable]

LATH3 - 1

Cable length (L)

1	1 m
3	3 m
5	5 m

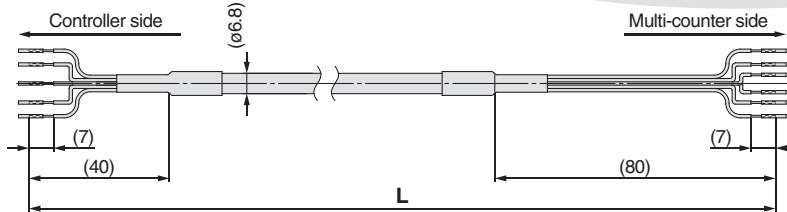

Wiring Diagram

Terminal no.	Circuit	Cable color
1	PhaseB	White
2	PhaseA	Red
3	GND	Light gray
4	RESET	Yellow
5	FG	Green

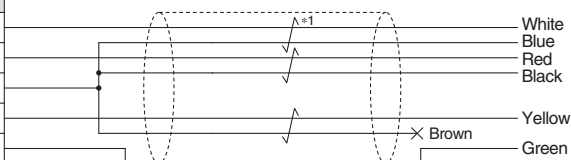



[Multi-counter]

This counter displays the table position of the Card Motor and performs preset outputs according to the program (preset data and output form, etc.) when measuring. The RS-232C can be used to send the table position to a PLC or PC or to set the Multi-counter.

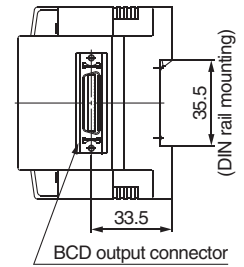
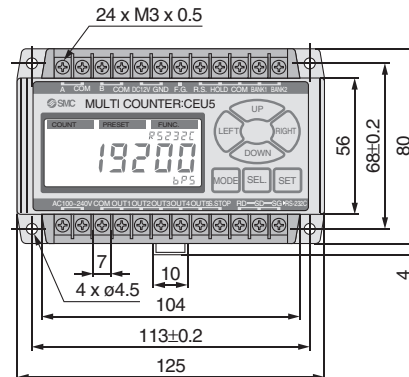
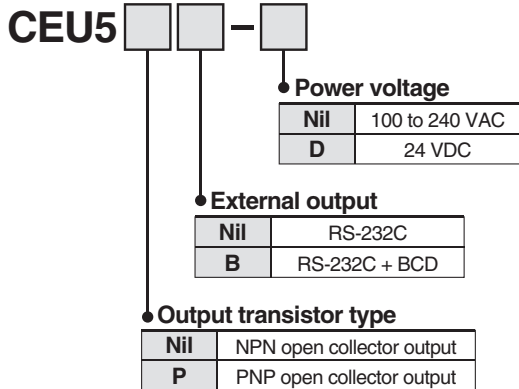

Specifications

Model	CEU5□□-□
Mounting method	Surface mounting (Fixed to DIN rail or screw)
Operation mode	Operating mode, Data setting mode, Function setting mode
Display type	LCD with backlight
Number of digits	6 digits
Counting speed	100 kHz
Insulation resistance	Between case and AC line: 500 VDC, 50 MΩ or more
Ambient temperature	32 to 122°F (0 to 50°C) (No freezing)
Ambient humidity	35 to 85%RH (No condensation)
Weight	12.3 oz (350 g) or less

*For details, refer to the Multi-counter catalog and operation manual that can be downloaded from the SMC website, <http://www.smcworld.com>

Wiring Example

Multi-counter CEU5 Terminal Block

Name	Cable color
A	Red
COM	Black
B	White
COM	Blue
12 VDC	-
GND	-
F.G.	Green
RESET	Yellow
HOLD	-
COM	-
BANK1	-
BANK2	-

Controller LATIC4 Counter Plug

Cable color	Name
White	PhaseB
Red	PhaseA
Light gray	GND
Yellow	RESET
Green	F.G.

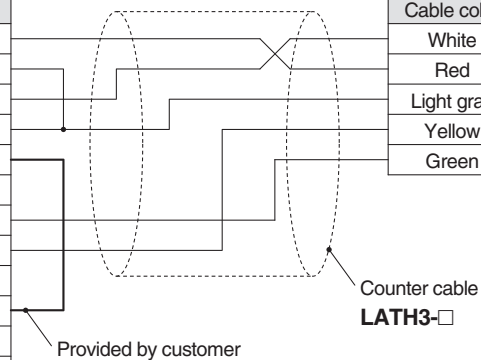

[Controller setup kit]

LATIC-W1

Controller setup kit
(Japanese and English are available.)

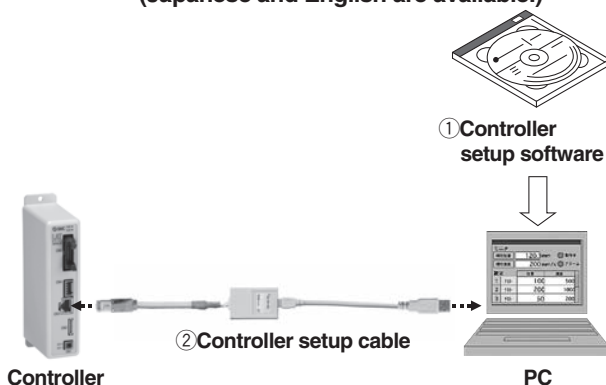

Contents

- ① Controller setup software (CD-ROM)
- ② Controller setup cable
(Communication cable, Conversion unit, USB cable)

Hardware Requirements

PC/AT compatible machine installed with Windows XP and equipped with USB1.1 or USB2.0 ports.

*Windows® and Windows XP® are registered trademarks of Microsoft Corporation.



Series LAT3 Specific Product Precautions 1

Be sure to read before handling. Refer to back cover for Safety Instructions. For Electric Actuator Precautions, refer to "Handling Precautions for SMC Products" (M-E03-3) and Operation Manual. Please download it via our website, <http://www.smcworld.com>

Design/Selection

⚠ Warning

1. Consider possible movements of the actuator in the event of an emergency stop, alarm or power failure.

If power is not supplied to the product due to an emergency stop or if the SVON signal is turned OFF, in the event of an alarm (when temperature of the Card Motor exceeds 158°F (70°C)) or at power failure, the table will not be held in place and may be moved by external forces. Design the Card Motor application so that people and equipment will not be injured or damaged by the table movement.

⚠ Caution

1. Do not apply a load outside the specifications.

The Card Motor should be fitted for the application based on the maximum workload and allowable moments. If the product is used outside the specifications, the excess load applied to the guide will lead to play in the guide, decrease in accuracy and the life span of the product will be shortened.

2. Do not use the product in applications where excessive external force or impact is applied to it.

Otherwise, a failure or malfunction can result.

3. The Card Motor is equipped with a stopper to prevent the table from coming off and to be resistant to light impacts generated by returning to home position or during transportation.

Thus, excessive external force or impact may damage the product, so please install a separate external stopper if the operating conditions require.

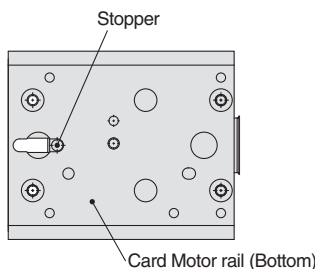

4. Strong magnet

The Card Motor contains a strong rare earth magnet, whose magnetic field may affect the workpiece. Mount the workpiece away from the Card Motor far enough to prevent the magnetic field from affecting the workpiece.

5. In pushing operation, use thrust setting values within the allowable limits.

Otherwise, it may cause overheating of the workpiece or the mounting surface.

6. The flatness of the mounting surface of the table and rail must be 0.02 mm or less.

Insufficient flatness of a workpiece the Card Motor is mounted to or of the base the Card Motor is mounted onto, can cause play in the guide and an increase in the sliding resistance.

Handling

⚠ Warning

1. Do not touch the product when it is energized or for a few minutes after it has been de-energized.

The surface temperature of the Card Motor can increase up to approximately 158°F (70°C) depending on the operating conditions. Energizing alone may also cause the temperature to increase. Do not touch the Card Motor during operation or when energized to prevent burns or other injuries.

⚠ Caution

1. Strong magnet

The Card Motor contains a strong rare earth magnet. If a magnetic card is brought close to the Card Motor, the card data may get distorted or lost. Do not bring items, which are sensitive to or affected by magnetism close to the product.

2. Do not operate the Card Motor continuously with an allowable set thrust or more at 100% of Duty.

The Card Motor may overheat due to the heat generated by the Card Motor itself, and a temperature error or malfunction may occur.

3. Do not hit the stroke ends during operation, except during return to home position and in pushing operation.

Otherwise, a failure can result.

4. For pushing operations, set the target position at least 1 mm away from the position where the pushing tool comes into contact with the workpiece.

Otherwise, the table may hit the workpiece at a speed exceeding the specified pushing speed.

5. The table and the guide rail are made of special stainless steel, but can rust in an environment where droplets of water adhere to it.

6. Do not dent, scratch or cause other damage to the steel ball rolling surface of the table and the rail.

Otherwise, it will result in play or increased sliding friction.

7. Positioning accuracy, thrust and measurement accuracy may vary after the Card Motor or the workload have been mounted, depending on the mounting conditions and environment.

Calibrate them according to the actual application.

8. Consider mounting a bumper on the pushing surface.

If impact to the Card Motor should be avoided during pushing operation, we recommend an elastic bumper is attached on the pushing surface.



Series LAT3 Specific Product Precautions 2

Be sure to read before handling. Refer to back cover for Safety Instructions. For Electric Actuator Precautions, refer to "Handling Precautions for SMC Products" (M-E03-3) and Operation Manual. Please download it via our website, <http://www.smcworld.com>

Installation

⚠ Caution

1. Strong magnet

The Card Motor contains a strong rare earth magnet. If magnetized workpieces, tools and metallic parts are brought in the vicinity of the Card Motor, they will be attracted, which could cause injury to operators and damage equipment. Take special care when handling and operating the product.

2. Mount the Card Motor on a base with good cooling performance, for example a metal plate.

If the cooling performance is not good enough, the temperature of the Card Motor will increase and a failure can result.

3. When mounting a workpiece, do not apply impact or large moment to the Card Motor.

If an external force higher than the allowable moment is applied, it may cause play in the guide part and an increase in the sliding friction or other problems.

4. Do not dent, scratch or cause other damage to the table and rail mounting surfaces.

Otherwise, it may cause a loss of parallelism in the mounting surfaces, looseness in the guide unit, an increase in sliding resistance or other problems.

5. When mounting the Card Motor, use stainless steel screws with appropriate length and tighten with recommended tightening torque.

If the maximum screw-in depth is exceeded, it may damage the internal components. Using a tightening torque higher than the specified torque may cause a malfunction, and using a lower tightening torque may displace the workpiece or cause it to drop off.

1) Body mounting/Body tapped

Bolt (Stainless steel)	M3 x 0.5
Max. recommended torque	0.46 lbf ft (0.63 [N·m])
L1 (Max. screw-in depth) [mm]	4.6
L2 (Plate thickness) [mm]	2.1

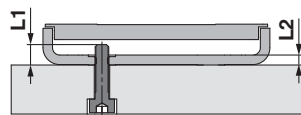

2) Body mounting/Through hole

Bolt (Stainless steel)	M2.5 x 0.45
Max. recommended torque	0.27 lbf ft (0.36 [N·m])
L3 (Max. screw-in depth) [mm]	2.5
L4 (Plate thickness) [mm]	2.1

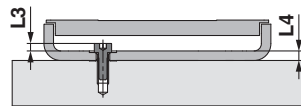

3) Workpiece mounting/Top mounting

Bolt (Stainless steel)	M3 x 0.5
Max. recommended torque	0.46 lbf ft (0.63 [N·m])
L5 (Max. screw-in depth) [mm]	2.5

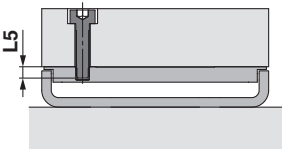

6. When connecting the cables, avoid applying any stress to the connector from the cable side.

If an external force or vibration is applied to the connector, a failure can result. Do not bend the cable for approximately 20 mm from the connector and fix this part of the cable with a cable fixture.

Grounding

⚠ Warning

1. Always ground the Card Motor.

2. Use a dedicated grounding.

Use a D-class grounding. (Ground resistance 100 Ω or less)

3. The grounding point should be as close as possible to the actuator, and the ground wires as short as possible.

Operating Environment

⚠ Caution

1. Do not use the products in an area where they could be exposed to dust, metallic powder, machining chips or splashes of water, oil or chemicals.

Otherwise, a failure or malfunction can result.

2. Do not use the products in a magnetic field.

Otherwise, the ambient magnetic field may affect the motor and a malfunction or failure can result.

3. Do not expose the product to a strong light sources, such as direct sunlight.

The Card Motor uses an optical sensor to detect the position, so if it is exposed to a strong light source such as direct sunlight, a malfunction could result. In such a case, install a light shielding plate such as a cover to shield the sensor from light.

4. Do not use the products in an environment where flammable, explosive or corrosive gases, liquids or other substances are present.

Otherwise, fire, explosion or corrosion can result.

5. Avoid heat radiation from strong heat sources, such as direct sunlight or a hot furnace.

Otherwise, the product can overheat and a failure can result.

6. Do not use the products in an environment with cyclic temperature changes.

Otherwise, a failure can result.

7. Use the products within the operating temperature and humidity range.

Maintenance

⚠ Caution

1. Perform regular maintenance and inspections.

Confirm that there is no twisting of wires, play in the table or large sliding friction. This may result in a malfunction.

2. Conduct an appropriate functional inspection and test after completed maintenance.

In case of any abnormalities (if the actuator does not move or the equipment does not operate properly, etc.), stop the operation of the system. Otherwise, unexpected malfunction may occur and safety cannot be assured. Conduct a test of the emergency stop to confirm the safety of the equipment.

3. Do not disassemble, modify or repair the product.

4. Maintenance space

Allow sufficient space for maintenance and inspection.



Series LAT3 Controller and Peripheral Devices/ Specific Product Precautions 1

Be sure to read before handling. Refer to back cover for Safety Instructions. For Electric Actuator Precautions, refer to "Handling Precautions for SMC Products" (M-E03-3) and Operation Manual. Please download it via our website, <http://www.smcworld.com>

Design/Selection

⚠ Warning

- 1. Use the specified voltage.**
If the applied voltage is higher than the specified voltage, malfunction and damage to the controller may result. If the applied voltage is lower than the specified voltage, there is a possibility that the load cannot be moved due to internal voltage drop. Check the operating voltage prior to start. Also, confirm that the operating voltage does not drop below the specified voltage during operation.
If the current is too low, the Card Motor may not be able to generate the maximum force or cause a malfunction.
- 2. Do not use the products outside the specifications.**
Otherwise, fire, malfunction or damage to the product can result. Check the specifications prior to use.
- 3. Install an emergency stop circuit.**
Install an emergency stop outside the enclosure in easy reach to the operator so that the operator can stop the system operation immediately and intercept the power supply.
- 4. To prevent danger and damage due to a breakdown or malfunction of these products, which may occur at a certain probability, a backup system should be arranged in advance by using a multiple-layered structure or by making a fail-safe equipment design, etc.**
- 5. If there is a risk of fire or personal injury due to abnormal heat generation, sparking, smoke generated by the product, etc., cut off the power supply from this product and the system immediately.**

Handling

⚠ Warning

- 1. Never touch the inside of the controller and its peripheral devices.**
Otherwise, electric shock or failure can result.
- 2. Do not operate or set up this equipment with wet hands.**
Otherwise, electric shock can result.
- 3. Do not use a product that is damaged or missing any components.**
Electric shock, fire or injury can result.
- 4. Do not connect the controller to other devices than the Card Motor.**
Otherwise, it may cause damage to the controller or to the other equipment.
- 5. Be careful not to touch, get caught or hit by the workpiece while the Card Motor is moving.**
An injury can result.
- 6. Do not connect the power supply or power up the product until it is confirmed that the workpiece can be moved safely within the area that can be reached by the workpiece.**
Otherwise, the movement of the workpiece may cause an accident.
- 7. Do not touch the product when it is energized and for some time after the power has been disconnected, as it is very hot.**
Otherwise, it may cause burns due to the high temperature.
- 8. Check the voltage using a tester at least 5 minutes after power-off when performing installation, wiring and maintenance.**
Otherwise, electric shock, fire or injury can result.
- 9. Static electricity may cause a malfunction or damage the controller. Do not touch the controller while power is supplied to it.**
Take sufficient safety measures to eliminate static electricity when it is necessary to touch the controller for maintenance.

Handling

⚠ Caution

- 1. When the Multi-counter is not used, attach the counter plug to the counter connector of the controller.**
If foreign matter such as metal fragments enters the counter connector, short-circuit may occur.
- 2. Be sure to perform return to home position prior to start.**
If the home position is not set, the product will not operate even if the step data is performed.
- 3. The positioning time entered and set in the controller setup software is just a target value. It cannot be guaranteed.**
The operation may not have been completed even if the set positioning time has passed. In such a case, the BUSY and INP digital output signals can be used to detect when the operation has been completed.
- 4. Set the "Load Mass" value in the controller setup software according to the approximate weight of jigs or workpieces mounted on the Card Motor.**
If the "Load Mass" value in the controller setup software and the weight of the workload are different, the product may vibrate or the positioning accuracy may be reduced.
- 5. When the load mounted on the Card Motor is small (such as 100 g or less) and the Card Motor has stopped at a target position, depending on the operating conditions the Card Motor may continuously hunt for the target position (vibrate) within the positioning accuracy range.**
Please contact an SMC Sales representative for how to improve it.
- 6. BUSY signal**
The BUSY signal turns ON when the Card Motor begins to operate, and it turns OFF when the operating speed reaches 2 mm/s or less. However, when the Card Motor operates at a slower speed than 5 mm/s, the BUSY signal may not turn ON at all.
- 7. INP output signal (OUT0)**
Both in positioning operation and pushing operation, the INP signal will turn ON when the table has reached within the INP output range of the target position.
In pushing operation, if the table exceeds the target position and moves outside the INP output range, the INP signal will turn OFF again.

Output range of the INP signal (OUT0)

Model	Output range (mm)
LAT3F-□	±0.05
LAT3-□	±0.3

Mounting

⚠ Warning

- 1. Install the controller and its peripheral devices on fireproof material.**
Direct installation on or near flammable material may cause fire.
- 2. Do not install these products in a place subject to vibration and impact.**
Otherwise, a malfunction or failure can result.
- 3. Do not mount the controller and its peripheral devices on the same base together with a large-sized electromagnetic contactor or no-fuse breaker that generate vibration. Mount them on different base plates, or keep the controller and its peripheral devices away from such vibration suppliers.**
Otherwise, a malfunction can result.
- 4. Install the controller and its peripheral devices on a flat surface.**
If the mounting surface is not flat or uneven, excessive force may be applied to the housing and other parts resulting in a malfunction.

Power Supply

⚠ Warning

- 1. Use a power supply with low noise between lines and between power and ground.**
In cases where noise is high, use an isolation transformer.
- 2. The power supplies should be separated between the controller power and the I/O signal power, and both power supplies must not be of "inrush-current limited" type.**
If the power supply is of "inrush-current limited" type, a voltage drop may occur during the acceleration or deceleration of the actuator.



Series LAT3 Controller and Peripheral Devices/ Specific Product Precautions 2

Be sure to read before handling. Refer to back cover for Safety Instructions. For Electric Actuator Precautions, refer to "Handling Precautions for SMC Products" (M-E03-3) and Operation Manual. Please download it via our website, <http://www.smcworld.com>

Power Supply

Warning

- Take appropriate measures to prevent surges from lightning. Ground the surge absorber for lightning separately from the grounding of the controller and its peripheral devices.
- Use the UL-certified products listed below as direct current power supplies.

(1) Limited voltage current circuit in accordance with UL 508.

A circuit in which power is supplied by secondary coil of an insulated transformer that meets the following conditions

- Maximum voltage (No load): 30 Vrms (42.4 V peak) or less
- Maximum current : ① 8 A or less (including short circuit)
② Limited by a circuit protector (such as a fuse) with the following ratings

Voltage without load (V peak)	Maximum current rating
0 to 20 [V]	5.0
Over 20 [V] up to 30 [V]	100 Peak voltage

(2) Circuit (of class 2) which is of maximum 30 Vrms (42.4 V peak) or less, with UL 1310 class 2 power supply unit or UL 1585 class 2 transformer.

Grounding

Warning

- Make sure the product is grounded to ensure the noise tolerance of the controller.
Otherwise, it may cause a malfunction, damage, electric shock or fire. Do not share the earth with devices or equipment that generates a strong electromagnetic noise.
- Use a dedicated grounding.
Use a D-class grounding. (Ground resistance 100 Ω or less)
- The grounding point should be as close as possible to the controller, and the ground wires as short as possible.
- In the unlikely event that malfunction is caused by the ground, it may be disconnected.

Wiring

Warning

- Preparation for wiring
Turn the power supply off before wiring or plugging and unplugging of connectors. Mount a protective cover on the terminal block after the wires have been connected.
- Do not route the digital I/O signal and power cables together.
Malfunctions stemming from noise may occur if the signal line and output lines are routed together.
- Confirm proper wiring before turning the power on.
Incorrect wiring will lead to malfunction or may damage the controller or its peripheral devices. Confirm that there is no mis-wiring before turning the power on.
- Reserve enough space for the routing of the cables
If the cables are forced into unreasonable positions, it may damage the cables and connectors, which may lead to misconnection and result in a malfunction. Avoid bending the cables in sharp angles close to the connectors or where they enter the product. Fix the cable as close as possible to the connectors so that mechanical stress cannot be applied to the connectors.

Operating Environment

Caution

- Do not use the products in an area where they could be exposed to dust, metallic powder, machining chips or splashes of water, oil or chemicals.
Otherwise, a failure or malfunction can result.
- Do not use the products in a magnetic field.
Otherwise, a malfunction or failure can result.
- Do not use the products in an environment where flammable, explosive or corrosive gases, liquids or other substances are present.
Otherwise, fire, explosion or corrosion can result.
- Avoid heat radiation from strong heat sources, such as direct sunlight or a hot furnace.
Otherwise, it will cause a failure to the controller or its peripheral devices.
- Do not use the products in an environment with cyclic temperature changes.
Otherwise, it will cause a failure to the controller or its peripheral devices.
- Do not use the products in an environment where surges are generated.
Devices (solenoid type lifters, high frequency induction furnaces, motors, etc.) that generate a large amount of surge around the product may lead to deterioration or damage to the internal circuits of the products. Avoid supplies of surge generation and crossed lines.
- The Card Motor and the controller are not immune to lightning strikes.
- Do not install these products in a place subject to vibration and impact.
Otherwise, a malfunction or failure can result.

Maintenance

Warning

- Perform maintenance checks periodically.
Confirm wiring and screws are not loose. Loose screws or wires may cause unexpected malfunction.
- Conduct an appropriate functional inspection and test after completed maintenance.
In case of any abnormalities (if the actuator does not move or the equipment does not operate properly, etc.), stop the operation of the system. Otherwise, unexpected malfunction may occur and safety cannot be assured. Conduct a test of the emergency stop to confirm the safety of the equipment.
- Do not disassemble, modify or repair the controller or its peripheral devices.
- Do not put anything conductive or flammable inside the controller.
Otherwise, fire can result.
- Do not conduct an insulation resistance test or insulation withstand voltage test.

Caution

- Reserve sufficient space for maintenance.
Design the system so that it allows required space for maintenance.

Safety Instructions

These safety instructions are intended to prevent hazardous situations and/or equipment damage. These instructions indicate the level of potential hazard with the labels of “**Caution**,” “**Warning**” or “**Danger**.” They are all important notes for safety and must be followed in addition to International Standards (ISO/IEC)*1), and other safety regulations.

 **Caution:** **Caution** indicates a hazard with a low level of risk which, if not avoided, could result in minor or moderate injury.

 **Warning:** **Warning** indicates a hazard with a medium level of risk which, if not avoided, could result in death or serious injury.

 **Danger:** **Danger** indicates a hazard with a high level of risk which, if not avoided, will result in death or serious injury.

*1) ISO 4414: Pneumatic fluid power – General rules relating to systems.
ISO 4413: Hydraulic fluid power – General rules relating to systems.
IEC 60204-1: Safety of machinery – Electrical equipment of machines.
(Part 1: General requirements)
ISO 10218-1: Manipulating industrial robots - Safety.
etc.

Warning

1. The compatibility of the product is the responsibility of the person who designs the equipment or decides its specifications.

Since the product specified here is used under various operating conditions, its compatibility with specific equipment must be decided by the person who designs the equipment or decides its specifications based on necessary analysis and test results. The expected performance and safety assurance of the equipment will be the responsibility of the person who has determined its compatibility with the product. This person should also continuously review all specifications of the product referring to its latest catalog information, with a view to giving due consideration to any possibility of equipment failure when configuring the equipment.

2. Only personnel with appropriate training should operate machinery and equipment.

The product specified here may become unsafe if handled incorrectly. The assembly, operation and maintenance of machines or equipment including our products must be performed by an operator who is appropriately trained and experienced.

3. Do not service or attempt to remove product and machinery/equipment until safety is confirmed.

1. The inspection and maintenance of machinery/equipment should only be performed after measures to prevent falling or runaway of the driven objects have been confirmed.
2. When the product is to be removed, confirm that the safety measures as mentioned above are implemented and the power from any appropriate source is cut, and read and understand the specific product precautions of all relevant products carefully.
3. Before machinery/equipment is restarted, take measures to prevent unexpected operation and malfunction.

4. Contact SMC beforehand and take special consideration of safety measures if the product is to be used in any of the following conditions.

1. Conditions and environments outside of the given specifications, or use outdoors or in a place exposed to direct sunlight.
2. Installation on equipment in conjunction with atomic energy, railways, air navigation, space, shipping, vehicles, military, medical treatment, combustion and recreation, or equipment in contact with food and beverages, emergency stop circuits, clutch and brake circuits in press applications, safety equipment or other applications unsuitable for the standard specifications described in the product catalog.
3. An application which could have negative effects on people, property, or animals requiring special safety analysis.
4. Use in an interlock circuit, which requires the provision of double interlock for possible failure by using a mechanical protective function, and periodical checks to confirm proper operation.

Caution

1. The product is provided for use in manufacturing industries.

The product herein described is basically provided for peaceful use in manufacturing industries.
If considering using the product in other industries, consult SMC beforehand and exchange specifications or a contract if necessary.
If anything is unclear, contact your nearest sales branch.

Limited warranty and Disclaimer/ Compliance Requirements

The product used is subject to the following “Limited warranty and Disclaimer” and “Compliance Requirements”.

Read and accept them before using the product.

Limited warranty and Disclaimer

1. The warranty period of the product is 1 year in service or 1.5 years after the product is delivered.*2)
Also, the product may have specified durability, running distance or replacement parts. Please consult your nearest sales branch.
2. For any failure or damage reported within the warranty period which is clearly our responsibility, a replacement product or necessary parts will be provided.
This limited warranty applies only to our product independently, and not to any other damage incurred due to the failure of the product.
3. Prior to using SMC products, please read and understand the warranty terms and disclaimers noted in the specified catalog for the particular products.

*2) **Vacuum pads are excluded from this 1 year warranty.**

A vacuum pad is a consumable part, so it is warranted for a year after it is delivered.
Also, even within the warranty period, the wear of a product due to the use of the vacuum pad or failure due to the deterioration of rubber material are not covered by the limited warranty.

Compliance Requirements

1. The use of SMC products with production equipment for the manufacture of weapons of mass destruction (WMD) or any other weapon is strictly prohibited.
2. The exports of SMC products or technology from one country to another are governed by the relevant security laws and regulations of the countries involved in the transaction. Prior to the shipment of a SMC product to another country, assure that all local rules governing that export are known and followed.

Safety Instructions

Be sure to read “Handling Precautions for SMC Products” (M-E03-3) before using.



SMC Corporation of America
10100 SMC Blvd., Noblesville, IN 46060

www.smcusa.com

SMC Pneumatics (Canada) Ltd.

www.smc Pneumatics.ca

(800) SMC.SMC1 (762-7621)

e-mail: sales@smcusa.com

For international inquiries: www.smcworld.com