

Electric Actuator with Integrated Guide

Series LTF

Series	Motor type	Guide type	Mounting orientation	Model	Lead screw lead mm				Page
					Ground ball screw		Rolled ball screw		
LTF	Standard motor	Frame-type linear guide	Horizontal	LTF6	6	10	6	10	Page 60 to
				LTF8	10	20	10	20	Page 68 to
			Vertical	LTF6	6	10	6	10	Page 76 to
				LTF8	10	20	10	20	Page 84 to

- Construction _____ Page 92
- Mounting _____ Page 93
- Deflection Data _____ Page 94

Part Number Designations

LTF 6 S2 P F - 100 - R R 2 A1 -

Series

6
8

Motor type

S2	AC servo motor (Incremental encoder) 100 W
S3	AC servo motor (Incremental encoder) 200 W
S6	AC servo motor (Absolute encoder) 100 W
S7	AC servo motor (Absolute encoder) 200 W

Lead screw type

P	Ground
N	Rolled

Lead screw lead

F	6 mm
H	10 mm
L	20 mm

Stroke (mm)

100

Brake

Nil	None
K	With IO connector

IO connector

Nil	None
H	With IO connector

Cable length

Nil	Without cable
2	2 m
5	5 m
A	10 m

Cable type

Nil	Without cable
S	Standard cable
R	Robotic cable (flexible cable)

Cable entry direction

Nil	Without cable
R	Right
L	Left

Photo micro switch

Nil	Without switch/mounting rail
1	NPN 1pc.
2	NPN 2pcs.
3	NPN 3pcs.
4	PNP 1pc.
5	PNP 2pcs.
6	PNP 3pcs.
A	Mounting rail

Driver type

Nil	Without driver
A1	Pulse input type (Incremental encoder) 100 V
A2	Pulse input type (Incremental encoder) 200 V
B1	Pulse input type (Absolute encoder) 100 V
B2	Pulse input type (Absolute encoder) 200 V

The tables above show the definition for each symbol only and cannot be used for actual model selection.

Standard Motor Horizontal Mount Series LTF6

Motor Output
100 W

Ground Ball Screw
∅10 mm/6 mm lead

How to Order

LTF6 S2 PF - 300 - R R 2 A1

Motor type

S2	AC servo motor (Incremental encoder) 100W
S6	AC servo motor (Absolute encoder) 100W

Stroke (mm)
Refer to the standard stroke.

Cable type

Nil	Without cable
S	Standard cable
R	Robotic cable (flexible cable)

Cable entry direction

Nil	Without cable
R	Right
L	Left

Cable length

Nil	Without cable
2	2 m
5	5 m
A	10 m

IO connector

Nil	None
H	With IO connector

Photo micro switch

Nil	Without switch/mounting rail
1	NPN 1pc.
2	NPN 2pcs.
3	NPN 3pcs.
4	PNP 1pcs.
5	PNP 2pc
6	PNP 3pcs.
A	Mounting rail

Driver type

Nil	Without driver
A1	Pulse input type (Incremental encoder) 100 V
A2	Pulse input type (Incremental encoder) 200 V
B1	Pulse input type (Absolute encoder) 100 V
B2	Pulse input type (Absolute encoder) 200 V

Left entry
Right entry
Motor/switch entry direction

Specifications

	Standard stroke (mm)	100	200	300	400	500	600
Performance	Body weight (kg)	2.2	2.7	3.2	3.7	4.2	4.7
	Operating temperature range (°C)	5 to 40 (No condensation)					
	Work load (kg)	30					
	Maximum speed (mm/s)	300					230
	Positioning repeatability (mm)	±0.02					
Main parts	Motor	AC servo motor (100 W)					
	Encoder	Incremental system/Absolute type					
	Lead screw	Ground ball screw ∅10 mm, 6 mm lead					
	Guide	Frame-type linear guide					
	Motor/Screw connection	With coupling					
Switch	Model	Photo micro sensor EE-SX674 (Refer to page 95 for details.)					
Driver	Model	LECS□□-□ (Refer to page 97 for details.)					

Allowable Moment (N·m)

Allowable dynamic moment

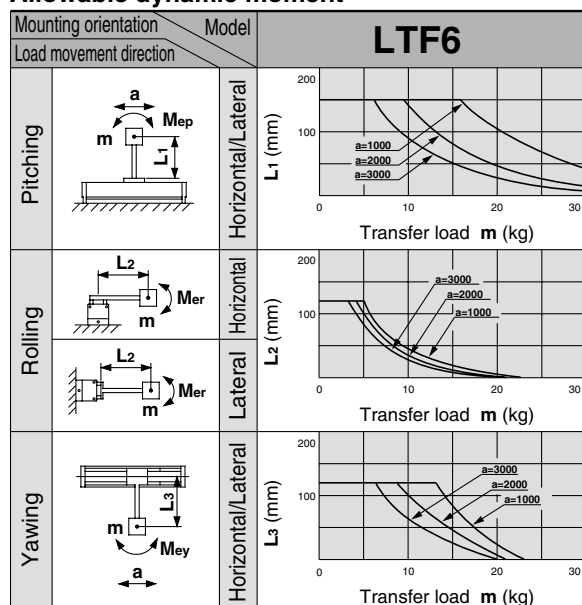

Investigation of the regeneration option

Depending on the conditions (speed, addition-subtraction speed, down time, load, etc.), the regeneration option may be required. The results of consideration in each case of maximum load or half load for the product specification are below. Please consult SMC when considering the necessity of the regeneration option.

Maximum load

Driver type	Regeneration option model
A1	Not required.
A2	Not required.
B1	Not required.
B2	Not required.

Half load

Driver type	Regeneration option model
A1	Not required.
A2	Not required.
B1	Not required.
B2	Not required.

Dimensions/LTF6□PF

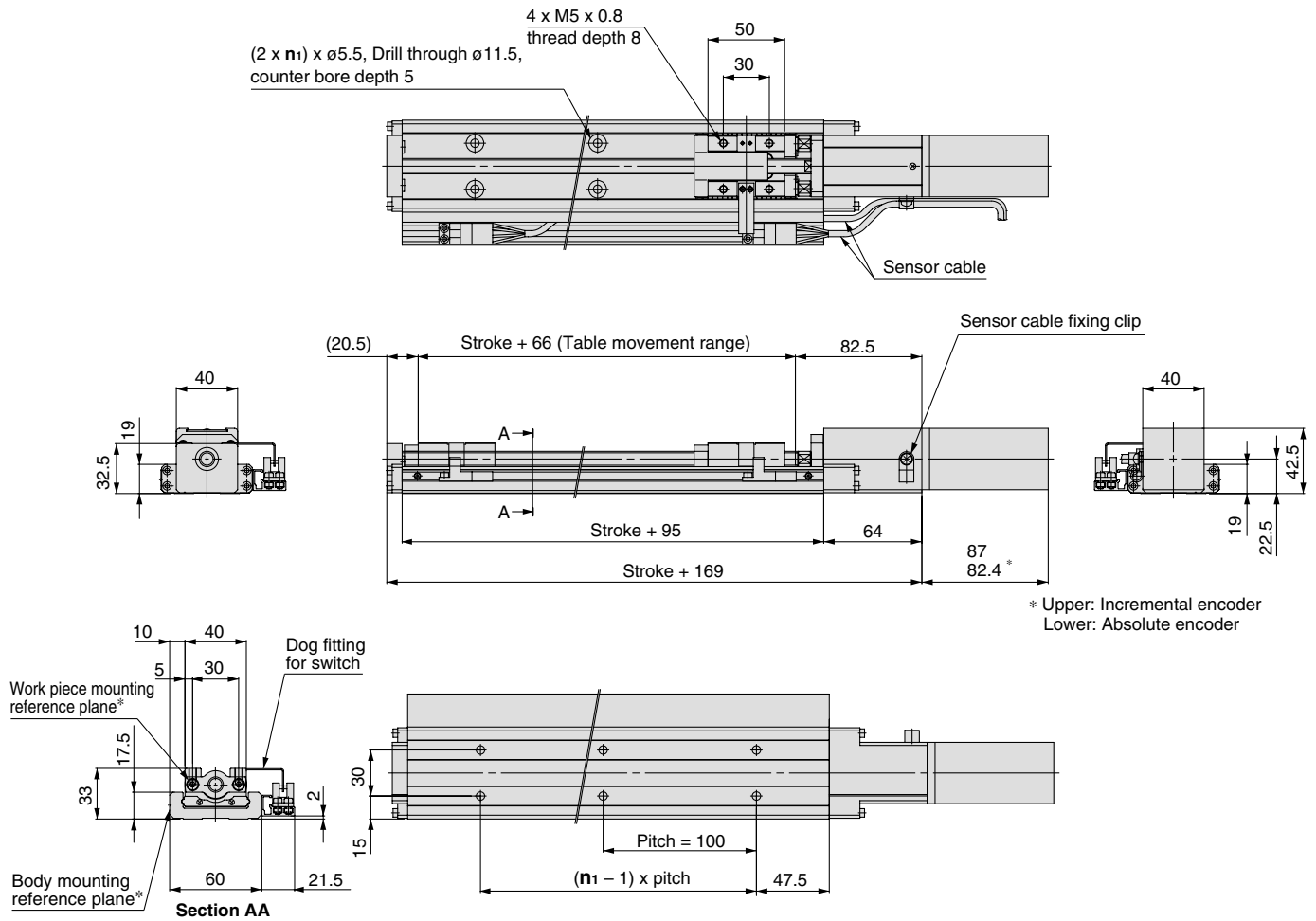

Model	Stroke	n ₁
LTF6□PF-100-□	100	2
LTF6□PF-200-□	200	3
LTF6□PF-300-□	300	4
LTF6□PF-400-□	400	5
LTF6□PF-500-□	500	6
LTF6□PF-600-□	600	7

* The body mounting reference plane and work piece mounting reference plane should be used as standards when mounting onto equipment. Refer to page 93 for mounting.

Positioning Time Guide

		Positioning time (sec.)				
		1	10	100	300	600
Speed (mm/s)	10	0.5	1.5	10.5	30.5	60.5
	100	0.5	0.6	1.5	3.5	6.5
	150	0.5	0.6	1.2	2.5	4.5
	300	0.5	0.6	0.9	1.6	2.6

* Values will vary slightly depending on the operating conditions.

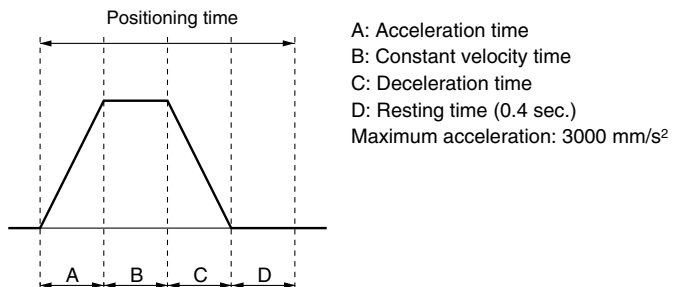

Standard Motor Horizontal Mount Series LTF6

Motor Output
100 W

Ground Ball Screw
∅ 10 mm/10 mm lead

How to Order

LTF6 S2 PH - 300 - R R 2 A1

Motor type

S2	AC servo motor (Incremental encoder) 100 W
S6	AC servo motor (Absolute encoder) 100 W

Stroke (mm)
Refer to the standard stroke.

Cable type

Nil	Without cable
S	Standard cable
R	Robotic cable (flexible cable)

Cable entry direction

Nil	Without cable
R	Right
L	Left

Cable length

Nil	Without cable
2	2 m
5	5 m
A	10 m

IO connector

Nil	None
H	With IO connector

Photo micro switch

Nil	Without switch/mounting rail
1	NPN 1pc.
2	NPN 2pcs.
3	NPN 3pcs.
4	PNP 1pc.
5	PNP 2pcs.
6	PNP 3pcs.
A	Mounting rail

Driver type

Nil	Without driver
A1	Pulse input type (Incremental encoder) 100 V
A2	Pulse input type (Incremental encoder) 200 V
B1	Pulse input type (Absolute encoder) 100 V
B2	Pulse input type (Absolute encoder) 200 V

Left entry
Right entry
Motor/switch entry direction

Specifications

Standard stroke (mm)		100	200	300	400	500	600
Performance	Body weight (kg)	2.2	2.7	3.2	3.7	4.2	4.7
	Operating temperature range (°C)	5 to 40 (No condensation)					
	Work load (kg)	15					
	Maximum speed (mm/s)	500					390
	Positioning repeatability (mm)	±0.02					
Main parts	Motor	AC servo motor (100 W)					
	Encoder	Incremental system/Absolute type					
	Lead screw	Ground ball screw ∅10 mm, 10 mm lead					
	Guide	Frame-type linear guide					
	Motor/Screw connection	With coupling					
Switch	Model	Photo micro sensor EE-SX674 (Refer to page 95 for details.)					
Driver	Model	LECS□□-□ (Refer to page 97 for details.)					

Allowable Moment (N·m)

Allowable dynamic moment

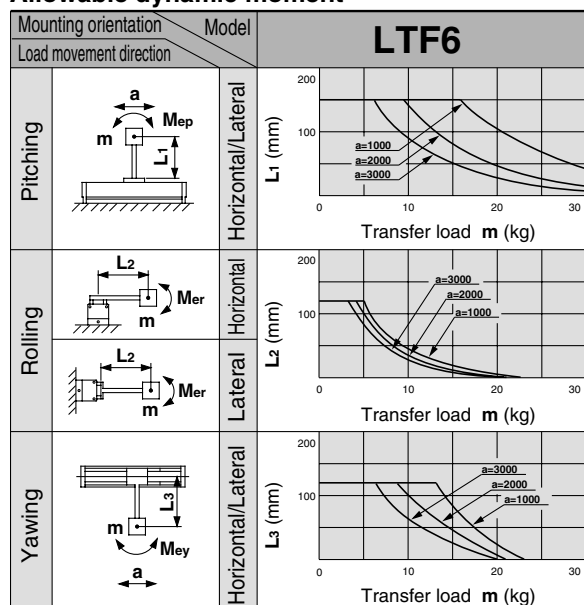

Investigation of the regeneration option

Depending on the conditions (speed, addition-subtraction speed, down time, load, etc.), the regeneration option may be required. The results of consideration in each case of maximum load or half load for the product specification are below. Please consult SMC when considering the necessity of the regeneration option.

Maximum load

Driver type	Regeneration option model
A1	Not required.
A2	Not required.
B1	Not required.
B2	Not required.

Half load

Driver type	Regeneration option model
A1	Not required.
A2	Not required.
B1	Not required.
B2	Not required.

Dimensions/LTF6□PH

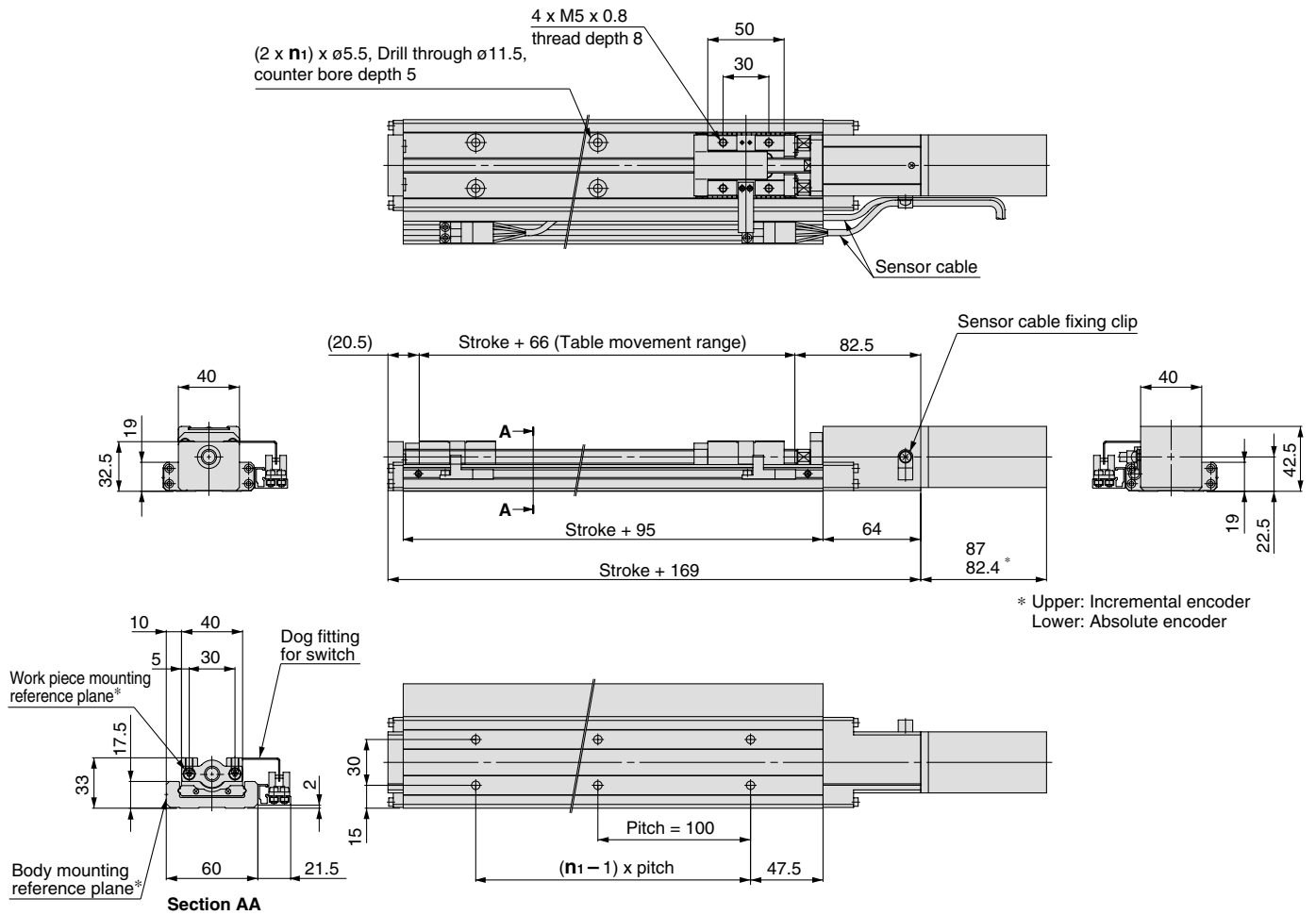

Model	Stroke	n1
LTF6□PH-100-□	100	2
LTF6□PH-200-□	200	3
LTF6□PH-300-□	300	4
LTF6□PH-400-□	400	5
LTF6□PH-500-□	500	6
LTF6□PH-600-□	600	7

* The body mounting reference plane and work piece mounting reference plane should be used as standards when mounting onto equipment. Refer to page 93 for mounting.

Positioning Time Guide

		Positioning time (sec.)				
		1	10	100	300	600
Speed (mm/s)	10	0.5	1.5	10.5	30.5	60.5
	100	0.5	0.6	1.5	3.5	6.5
	250	0.5	0.6	0.9	1.7	2.9
	500	0.5	0.6	0.8	1.2	1.8

* Values will vary slightly depending on the operating conditions.

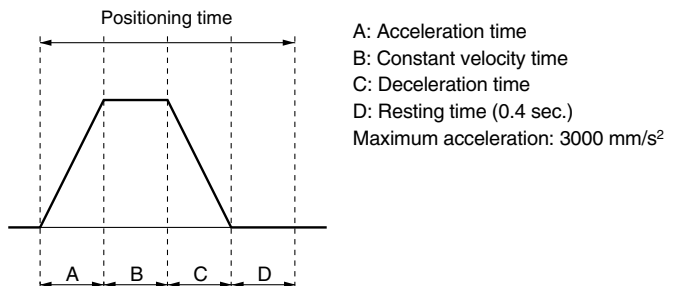

Standard Motor Horizontal Mount Series LTF6

Motor Output
100 W

Rolled Ball Screw
∅10 mm/6 mm lead

How to Order

LTF6 S2 NF - 300 - R R 2 A1

Motor type

S2	AC servo motor (Incremental encoder) 100 W
S6	AC servo motor (Absolute encoder) 100 W

Stroke (mm)
Refer to the standard stroke.

Motor type

Nil	Without cable
S	Standard cable
R	Robotic cable (flexible cable)

IO connector

Nil	None
H	With IO connector

Photo micro switch

Nil	Without switch/mounting rail
1	NPN 1pc.
2	NPN 2pcs.
3	NPN 3pcs.
4	PNP 1pc.
5	PNP 2pcs.
6	PNP 3pcs.
A	Mounting rail

Driver type

Nil	Without driver
A1	Pulse input type (Incremental encoder) 100 V
A2	Pulse input type (Incremental encoder) 200 V
B1	Pulse input type (Absolute encoder) 100 V
B2	Pulse input type (Absolute encoder) 200 V

Cable entry direction

Nil	Without cable
R	Right
L	Left

Cable length

Nil	Without cable
2	2 m
5	5 m
A	10 m

Motor/switch entry direction

Specifications

	Standard stroke (mm)	100	200	300	400	500	600
Performance	Body weight (kg)	2.2	2.7	3.2	3.7	4.2	4.7
	Operating temperature range (°C)	5 to 40 (No condensation)					
	Work load (kg)	30					
	Maximum speed (mm/s)	300					230
	Positioning repeatability (mm)	±0.05					
Main parts	Motor	AC servo motor (100 W)					
	Encoder	Incremental system/Absolute type					
	Lead screw	Rolled ball screw ∅10 mm, 6 mm lead					
	Guide	Frame-type linear guide					
	Motor/Screw connection	With coupling					
Switch	Model	Photo micro sensor EE-SX674 (Refer to page 95 for details.)					
Driver	Model	LECS□□-□ (Refer to page 97 for details.)					

Allowable Moment (N·m)

Allowable dynamic moment

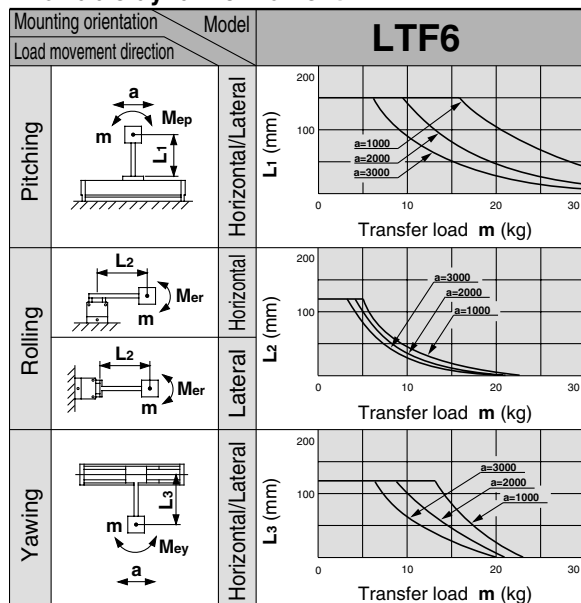

Investigation of the regeneration option

Depending on the conditions (speed, addition-subtraction speed, down time, load, etc.), the regeneration option may be required. The results of consideration in each case of maximum load or half load for the product specification are below. Please consult SMC when considering the necessity of the regeneration option.

Maximum load

Driver type	Regeneration option model
A1	Not required.
A2	Not required.
B1	Not required.
B2	Not required.

Half load

Driver type	Regeneration option model
A1	Not required.
A2	Not required.
B1	Not required.
B2	Not required.

Dimensions/LTF6□NF

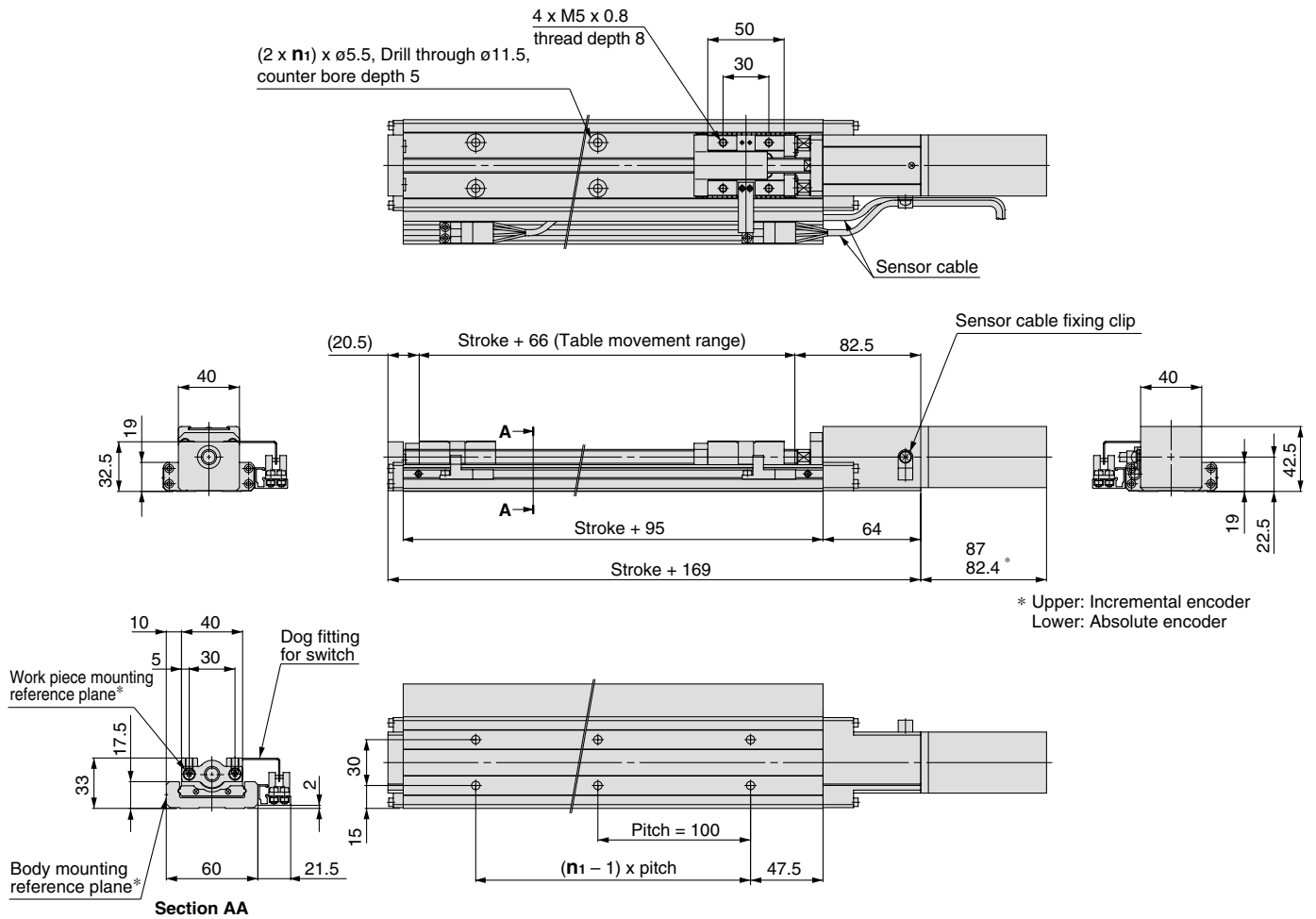

Model	Stroke	n ₁
LTF6□NF-100-□	100	2
LTF6□NF-200-□	200	3
LTF6□NF-300-□	300	4
LTF6□NF-400-□	400	5
LTF6□NF-500-□	500	6
LTF6□NF-600-□	600	7

* The body mounting reference plane and work piece mounting reference plane should be used as standards when mounting onto equipment. Refer to page 93 for mounting.

Positioning Time Guide

		Positioning time (sec.)				
		1	10	100	300	600
Speed (mm/s)	10	0.5	1.5	10.5	30.5	60.5
	100	0.5	0.6	1.5	3.5	6.5
	150	0.5	0.6	1.2	2.5	4.5
	300	0.5	0.6	0.9	1.6	2.6

* Values will vary slightly depending on the operating conditions.

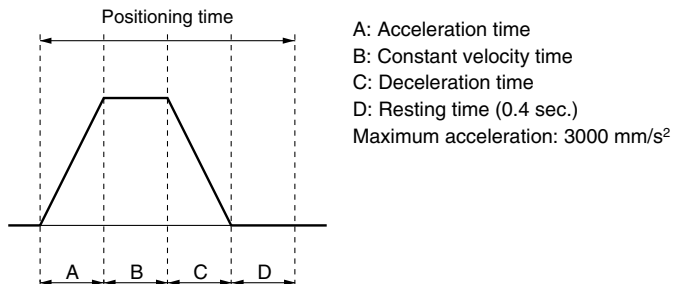

Standard Motor Horizontal Mount Series LTF6

Motor Output
100 W

Rolled Ball Screw
∅10 mm/10 mm lead

How to Order

LTF6 S2 NH - 300 - R R 2 A1

Motor type

S2	AC servo motor (Incremental encoder) 100 W
S6	AC servo motor (Absolute encoder) 100 W

Stroke (mm)
Refer to the standard stroke.

Cable type

Nil	Without cable
S	Standard cable
R	Robotic cable (flexible cable)

Cable entry direction

Nil	Without cable
R	Right
L	Left

Cable length

Nil	Without cable
2	2 m
5	5 m
A	10 m

IO connector

Nil	None
H	With IO connector

Photo micro switch

Nil	Without switch/mounting rail
1	NPN 1pc.
2	NPN 2pcs.
3	NPN 3pcs.
4	PNP 1pc.
5	PNP 2pcs.
6	PNP 3pcs.
A	Mounting rail

Driver type

Nil	Without driver
A1	Pulse input type (Incremental encoder) 100 V
A2	Pulse input type (Incremental encoder) 200 V
B1	Pulse input type (Absolute encoder) 100 V
B2	Pulse input type (Absolute encoder) 200 V

Specifications

		100	200	300	400	500	600
Performance	Standard stroke (mm)	100	200	300	400	500	600
	Body weight (kg)	2.2	2.7	3.2	3.7	4.2	4.7
	Operating temperature range (°C)	5 to 40 (No condensation)					
	Work load (kg)	15					
	Maximum speed (mm/s)	500					390
Main parts	Positioning repeatability (mm)	±0.05					
	Motor	AC servo motor (100 W)					
	Encoder	Incremental system/Absolute type					
	Lead screw	Rolled ball screw ∅10 mm, 10 mm lead					
	Guide	Frame-type linear guide					
	Motor/Screw connection	With coupling					
Switch	Model	Photo micro sensor EE-SX674 (Refer to page 95 for details.)					
Driver	Model	LECS□□-□ (Refer to page 97 for details.)					

Allowable Moment (N·m)

Allowable dynamic moment

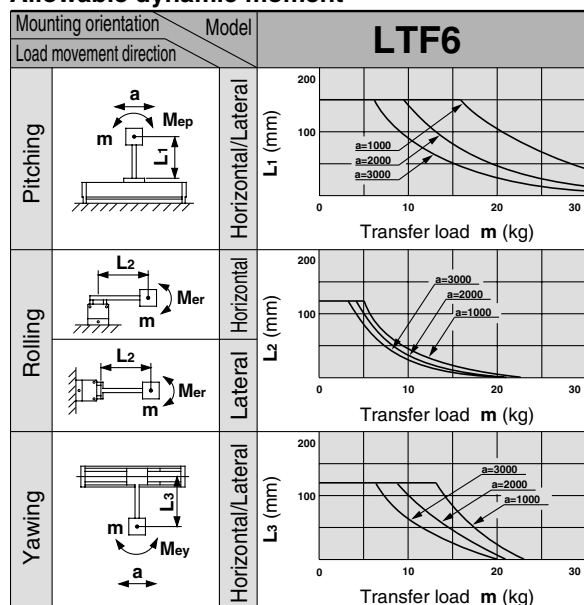

Investigation of the regeneration option

Depending on the conditions (speed, addition-subtraction speed, down time, load, etc.), the regeneration option may be required. The results of consideration in each case of maximum load or half load for the product specification are below. Please consult SMC when considering the necessity of the regeneration option.

Maximum load

Driver type	Regeneration option model
A1	Not required.
A2	Not required.
B1	Not required.
B2	Not required.

Half load

Driver type	Regeneration option model
A1	Not required.
A2	Not required.
B1	Not required.
B2	Not required.

Dimensions/LTF6□NH

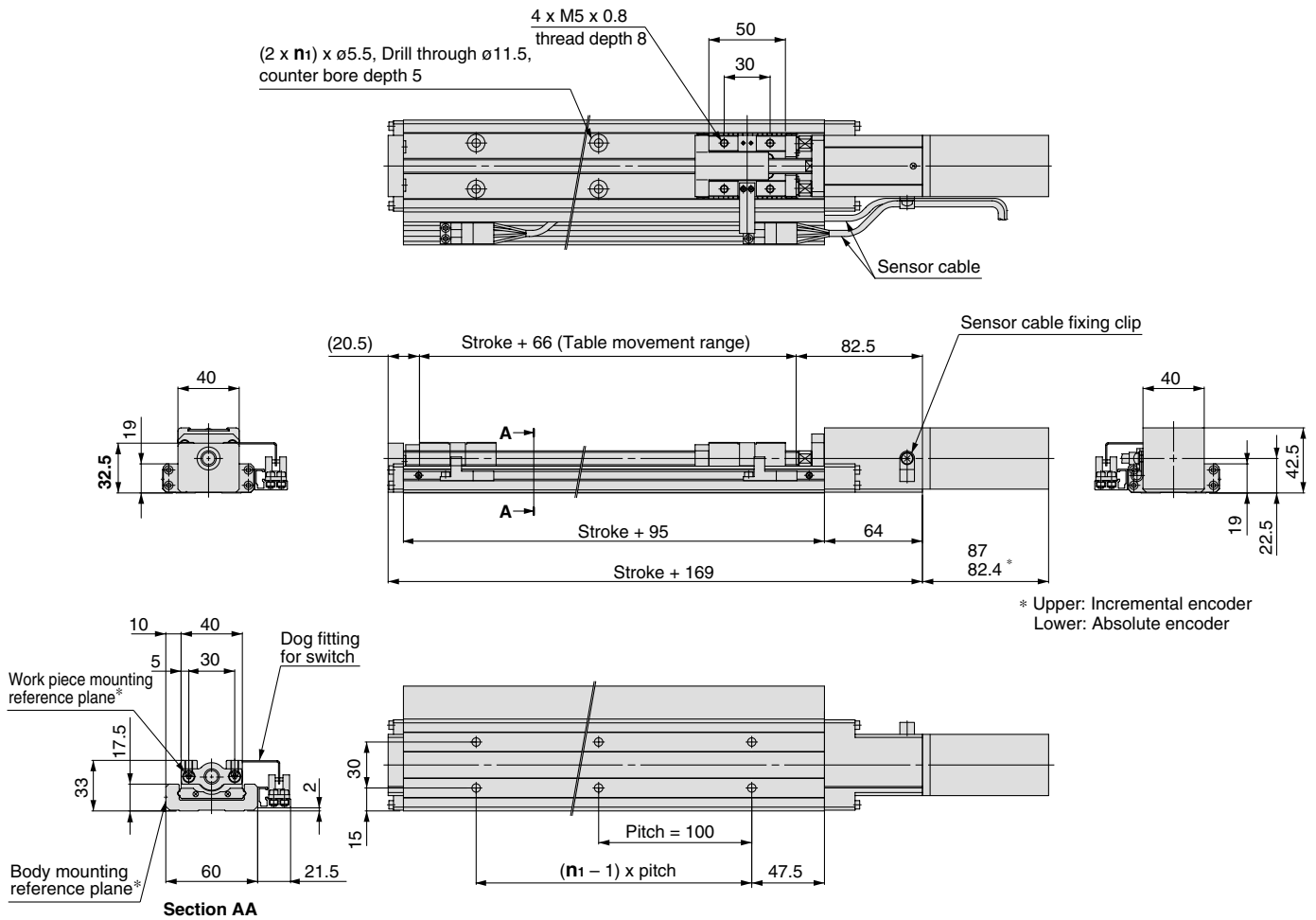

Model	Stroke	n ₁
LTF6□NH-100-□	100	2
LTF6□NH-200-□	200	3
LTF6□NH-300-□	300	4
LTF6□NH-400-□	400	5
LTF6□NH-500-□	500	6
LTF6□NH-600-□	600	7

* The body mounting reference plane and work piece mounting reference plane should be used as standards when mounting onto equipment. Refer to page 93 for mounting.

Positioning Time Guide

		Positioning time (sec.)				
		1	10	100	300	600
Speed (mm/s)	10	0.5	1.5	10.5	30.5	60.5
	100	0.5	0.6	1.5	3.5	6.5
	250	0.5	0.6	0.9	1.7	2.9
	500	0.5	0.6	0.8	1.2	1.8

* Values will vary slightly depending on the operating conditions.

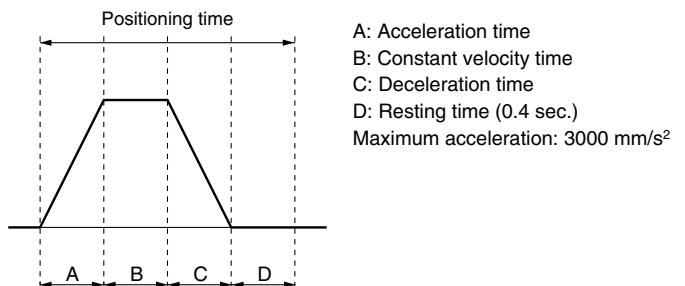

Standard Motor Horizontal Mount Series LTF8

Motor Output
200 W

Ground Ball Screw
∅15 mm/10 mm lead

How to Order

LTF8 S3 PH - 300 - R R 2 A1

Motor type

S3	AC servo motor (Incremental encoder) 200 W
S7	AC servo motor (Absolute encoder) 200 W

Stroke (mm)
Refer to the standard stroke.

Cable type

Nil	Without cable
S	Standard cable
R	Robotic cable (flexible cable)

Cable entry direction

Nil	Without cable
R	Right
L	Left

Cable length

Nil	Without cable
2	2 m
5	5 m
A	10 m

IO connector

Nil	None
H	With IO connector

Photo micro switch

Nil	Without switch/mounting rail
1	NPN 1pc.
2	NPN 2pcs.
3	NPN 3pcs.
4	PNP 1pc.
5	PNP 2pcs.
6	PNP 3pcs.
A	Mounting rail

Driver type

Nil	Without driver
A1	Pulse input type (Incremental encoder) 100 V
A2	Pulse input type (Incremental encoder) 200 V
B1	Pulse input type (Absolute encoder) 100 V
B2	Pulse input type (Absolute encoder) 200 V

Motor/switch entry direction

Specifications

Standard stroke (mm)		100	200	300	400	500	600	700	800	900	1000
Performance	Body weight (kg)	4.6	5.5	6.3	7.1	8.0	8.8	9.6	10.5	11.3	12.1
	Operating temperature range (°C)	5 to 40 (No condensation)									
	Work load (kg)	50									
	Maximum speed (mm/s)	500						440	350	290	240
	Positioning repeatability (mm)	±0.02									
Main parts	Motor	AC servo motor (200 W)									
	Encoder	Incremental system/Absolute type									
	Lead screw	Ground ball screw ∅15 mm, 10 mm lead									
	Guide	Frame-type linear guide									
	Motor/Screw connection	With coupling									
Switch	Model	Photo micro sensor EE-SX674 (Refer to page 95 for details.)									
Driver	Model	LECS□□□□ (Refer to page 97 for details.)									

Allowable Moment (N·m)

Allowable dynamic moment

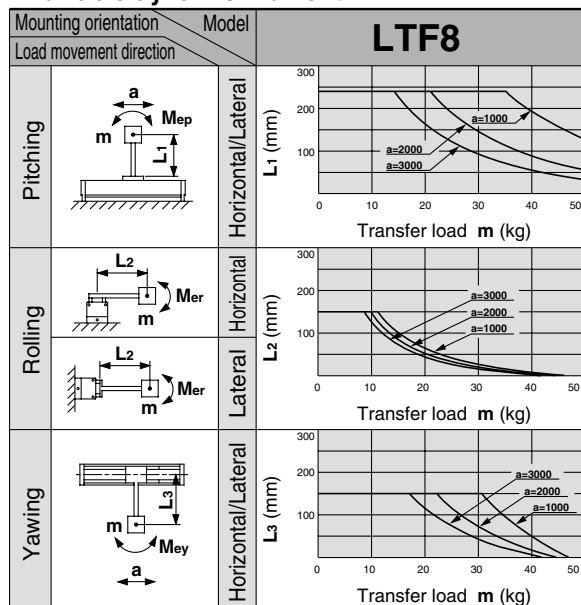

Investigation of the regeneration option

Depending on the conditions (speed, addition-subtraction speed, down time, load, etc.), the regeneration option may be required. The results of consideration in each case of maximum load or half load for the product specification are below. Please consult SMC when considering the necessity of the regeneration option.

Maximum load

Driver type	Regeneration option model
A1	Not required.
A2	Not required.
B1	Not required.
B2	Not required.

Half load

Driver type	Regeneration option model
A1	Not required.
A2	Not required.
B1	Not required.
B2	Not required.

Dimensions/LTF8□PH

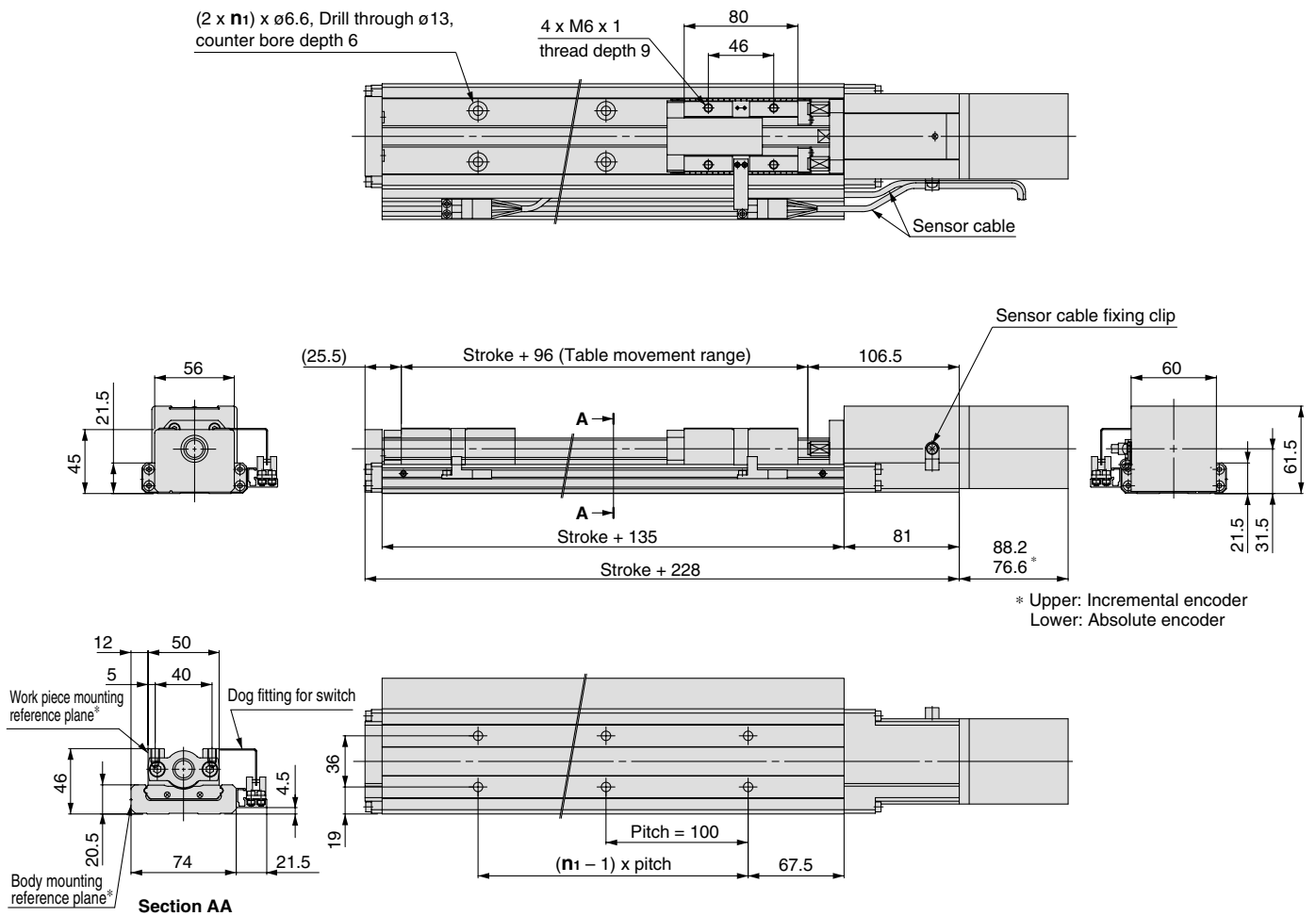

Model	Stroke	n ₁
LTF8□□PH- 100-□	100	2
LTF8□□PH- 200-□	200	3
LTF8□□PH- 300-□	300	4
LTF8□□PH- 400-□	400	5
LTF8□□PH- 500-□	500	6
LTF8□□PH- 600-□	600	7
LTF8□□PH- 700-□	700	8
LTF8□□PH- 800-□	800	9
LTF8□□PH- 900-□	900	10
LTF8□□PH-1000-□	1000	11

* The body mounting reference plane and work piece mounting reference plane should be used as standards when mounting onto equipment. Refer to page 93 for mounting.

Positioning Time Guide

		Positioning time (sec.)				
		1	10	100	500	1000
Speed (mm/s)	10	0.6	1.6	10.6	50.6	100.6
	100	0.6	0.7	1.6	5.6	10.6
	250	0.6	0.7	1.0	2.6	4.6
	500	0.6	0.7	0.9	1.7	2.7

* Values will vary slightly depending on the operating conditions.

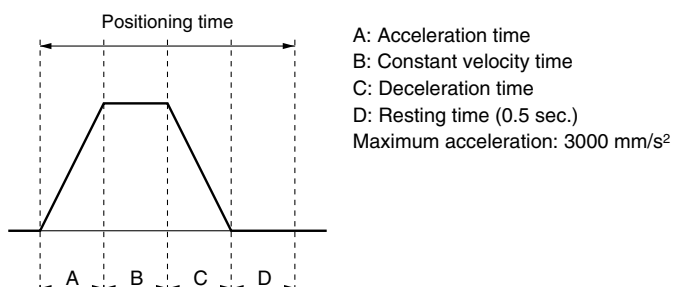

Standard Motor Horizontal Mount Series LTF8

Motor Output
200 W

Ground Ball Screw
∅15 mm/20 mm lead

How to Order

LTF8 S3 PL - 300 - R R 2 A1

Motor type

S3	AC servo motor (Incremental encoder) 200 W
S7	AC servo motor (Absolute encoder) 200 W

Stroke (mm)
Refer to the standard stroke.

Cable type

Nil	Without cable
S	Standard cable
R	Robotic cable (flexible cable)

Cable entry direction

Nil	Without cable
R	Right
L	Left

Cable length

Nil	Without cable
2	2 m
5	5 m
A	10 m

IO connector

Nil	None
H	With IO connector

Photo micro switch

Nil	Without switch/mounting rail
1	NPN 1pc.
2	NPN 2pcs.
3	NPN 3pcs.
4	PNP 1pc.
5	PNP 2pcs.
6	PNP 3pcs.
A	Mounting rail

Driver type

Nil	Without driver
A1	Pulse input type (Incremental encoder) 100 V
A2	Pulse input type (Incremental encoder) 200 V
B1	Pulse input type (Absolute encoder) 100 V
B2	Pulse input type (Absolute encoder) 200 V

Left entry
Right entry
Motor/switch entry direction

Specifications

Standard stroke (mm)		100	200	300	400	500	600	700	800	900	1000
Performance	Body weight (kg)	4.6	5.5	6.3	7.1	8.0	8.8	9.6	10.5	11.3	12.1
	Operating temperature range (°C)	5 to 40 (No condensation)									
	Work load (kg)	25									
	Maximum speed (mm/s)	1000						890	710	580	480
	Positioning repeatability (mm)	±0.02									
Main parts	Motor	AC servo motor (200 W)									
	Encoder	Incremental system/Absolute type									
	Lead screw	Ground ball screw ∅15 mm, 20 mm lead									
	Guide	Frame-type linear guide									
	Motor/Screw connection	With coupling									
Switch	Model	Photo micro sensor EE-SX674 (Refer to page 95 for details.)									
Driver	Model	LECS□□-□ (Refer to page 97 for details.)									

Allowable Moment (N·m)

Allowable dynamic moment

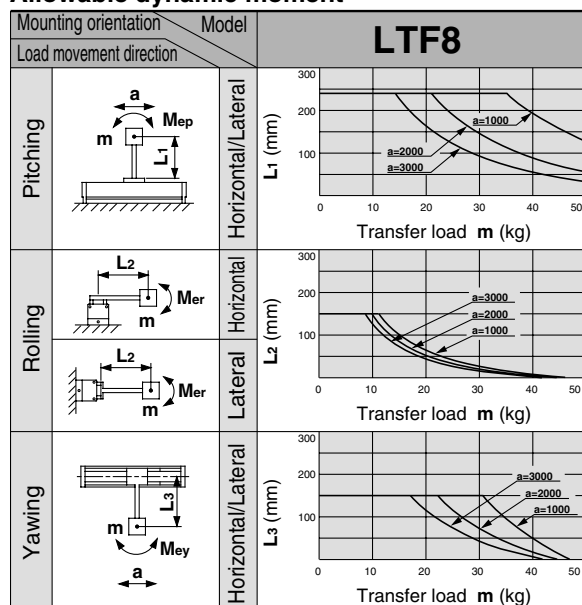

Investigation of the regeneration option

Depending on the conditions (speed, addition-subtraction speed, down time, load, etc.), the regeneration option may be required. The results of consideration in each case of maximum load or half load for the product specification are below. Please consult SMC when considering the necessity of the regeneration option.

Maximum load

Driver type	Regeneration option model
A1	Not required.
A2	Not required.
B1	Not required.
B2	Not required.

Half load

Driver type	Regeneration option model
A1	Not required.
A2	Not required.
B1	Not required.
B2	Not required.

Dimensions/LTF8□PL

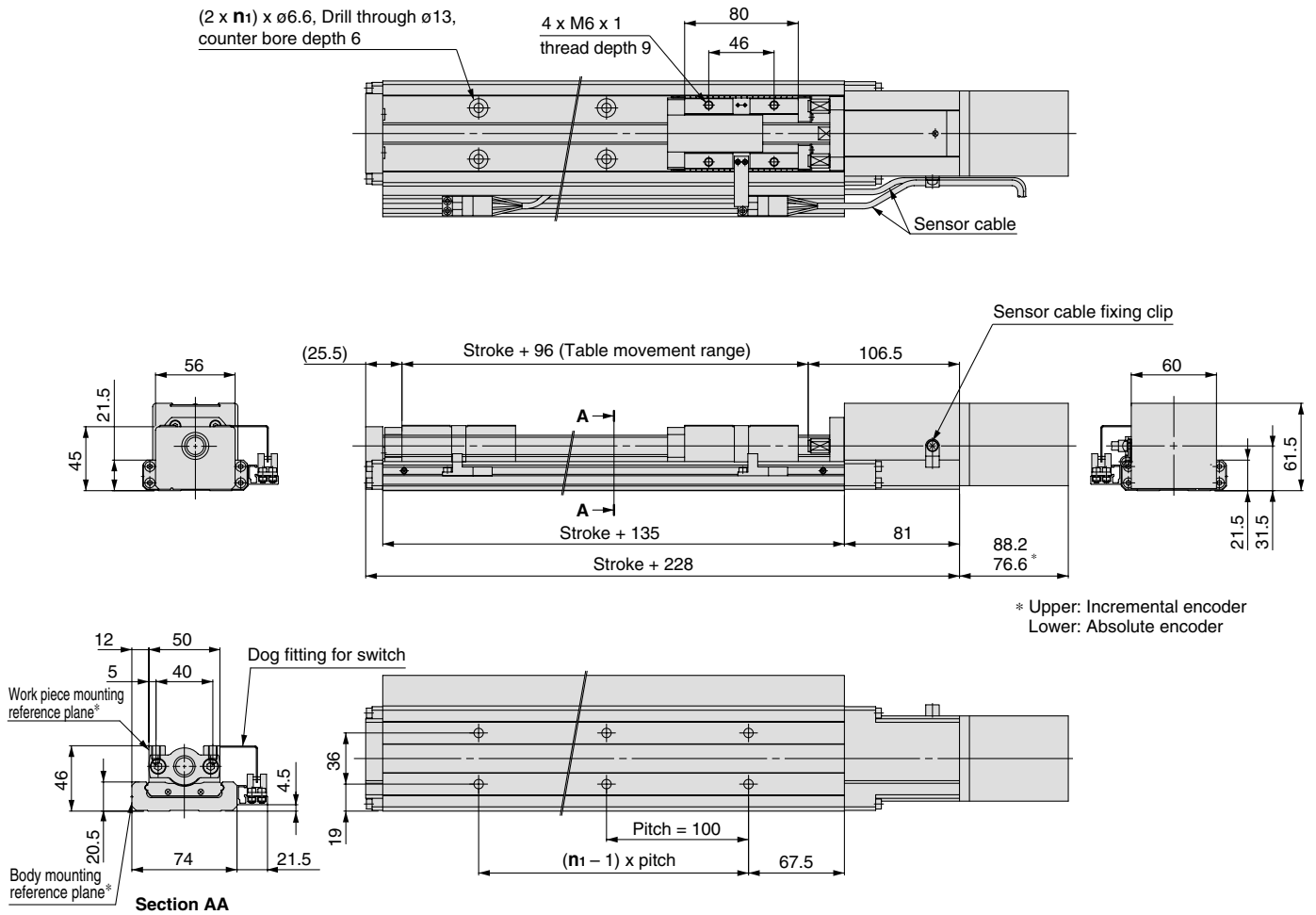

Model	Stroke	n ₁
LTF8□PL- 100-□	100	2
LTF8□PL- 200-□	200	3
LTF8□PL- 300-□	300	4
LTF8□PL- 400-□	400	5
LTF8□PL- 500-□	500	6
LTF8□PL- 600-□	600	7
LTF8□PL- 700-□	700	8
LTF8□PL- 800-□	800	9
LTF8□PL- 900-□	900	10
LTF8□PL-1000-□	1000	11

* The body mounting reference plane and work piece mounting reference plane should be used as standards when mounting onto equipment. Refer to page 93 for mounting.

Positioning Time Guide

		Positioning time (sec.)				
		1	10	100	500	1000
Speed (mm/s)	10	0.6	1.6	10.6	50.6	100.6
	100	0.6	0.7	1.6	5.6	10.6
	500	0.6	0.7	0.9	1.7	2.7
	1000	0.6	0.7	0.9	1.4	1.9

* Values will vary slightly depending on the operating conditions.

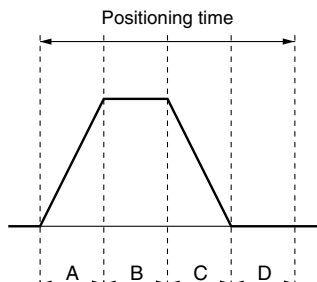

A: Acceleration time
B: Constant velocity time
C: Deceleration time
D: Resting time (0.5 sec.)
Maximum acceleration: 3000 mm/s²

Standard Motor Horizontal Mount Series LTF8

Motor Output
200 W

Rolled Ball Screw
∅15 mm/10 mm lead

How to Order

LTF8 S3 NH - 300 - R R 2 A1

Motor type

S3	AC servo motor (Incremental encoder) 200 W
S7	AC servo motor (Absolute encoder) 200 W

Stroke (mm)
Refer to the standard stroke.

Cable type

Nil	Without cable
S	Standard cable
R	Robotic cable (flexible cable)

Cable length

Nil	Without cable
2	2 m
5	5 m
A	10 m

Cable entry direction

Nil	Without cable
R	Right
L	Left

IO connector

Nil	None
H	With IO connector

Driver type

Nil	Without driver
A1	Pulse input type (Incremental encoder) 100 V
A2	Pulse input type (Incremental encoder) 200 V
B1	Pulse input type (Absolute encoder) 100 V
B2	Pulse input type (Absolute encoder) 200 V

Photo micro switch

Nil	Without switch/mounting rail
1	NPN 1pc.
2	NPN 2pcs.
3	NPN 3pcs.
4	PNP 1pc.
5	PNP 2pcs.
6	PNP 3pcs.
A	Mounting rail

Motor/switch entry direction

Specifications

		100	200	300	400	500	600	700	800	900	1000	
Performance	Standard stroke (mm)											
	Body weight (kg)	4.6	5.5	6.3	7.1	8.0	8.8	9.6	10.5	11.3	12.1	
	Operating temperature range (°C)	5 to 40 (No condensation)										
	Work load (kg)	50										
	Maximum speed (mm/s)	500						440	350	290	240	
Main parts	Positioning repeatability (mm)	±0.05										
	Motor	AC servo motor (200 W)										
	Encoder	Incremental system/Absolute type										
	Lead screw	Rolled ball screw ∅15 mm, 10 mm lead										
	Guide	Frame-type linear guide										
Switch	Motor/Screw connection	With coupling										
	Model	Photo micro sensor EE-SX674 (Refer to page 95 for details.)										
Driver	Model	LECS□□-□ (Refer to page 97 for details.)										

Allowable Moment (N·m)

Allowable dynamic moment

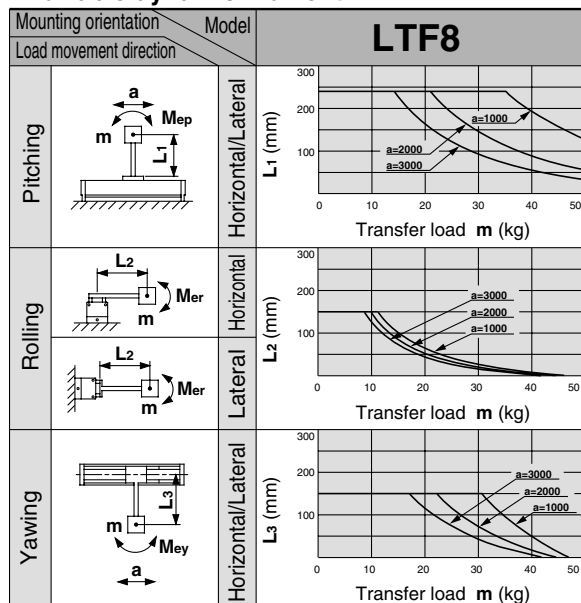

Investigation of the regeneration option

Depending on the conditions (speed, addition-subtraction speed, down time, load, etc.), the regeneration option may be required. The results of consideration in each case of maximum load or half load for the product specification are below. Please consult SMC when considering the necessity of the regeneration option.

Maximum load

Driver type	Regeneration option model
A1	Not required.
A2	Not required.
B1	Not required.
B2	Not required.

Half load

Driver type	Regeneration option model
A1	Not required.
A2	Not required.
B1	Not required.
B2	Not required.

Dimensions/LTF8□NH

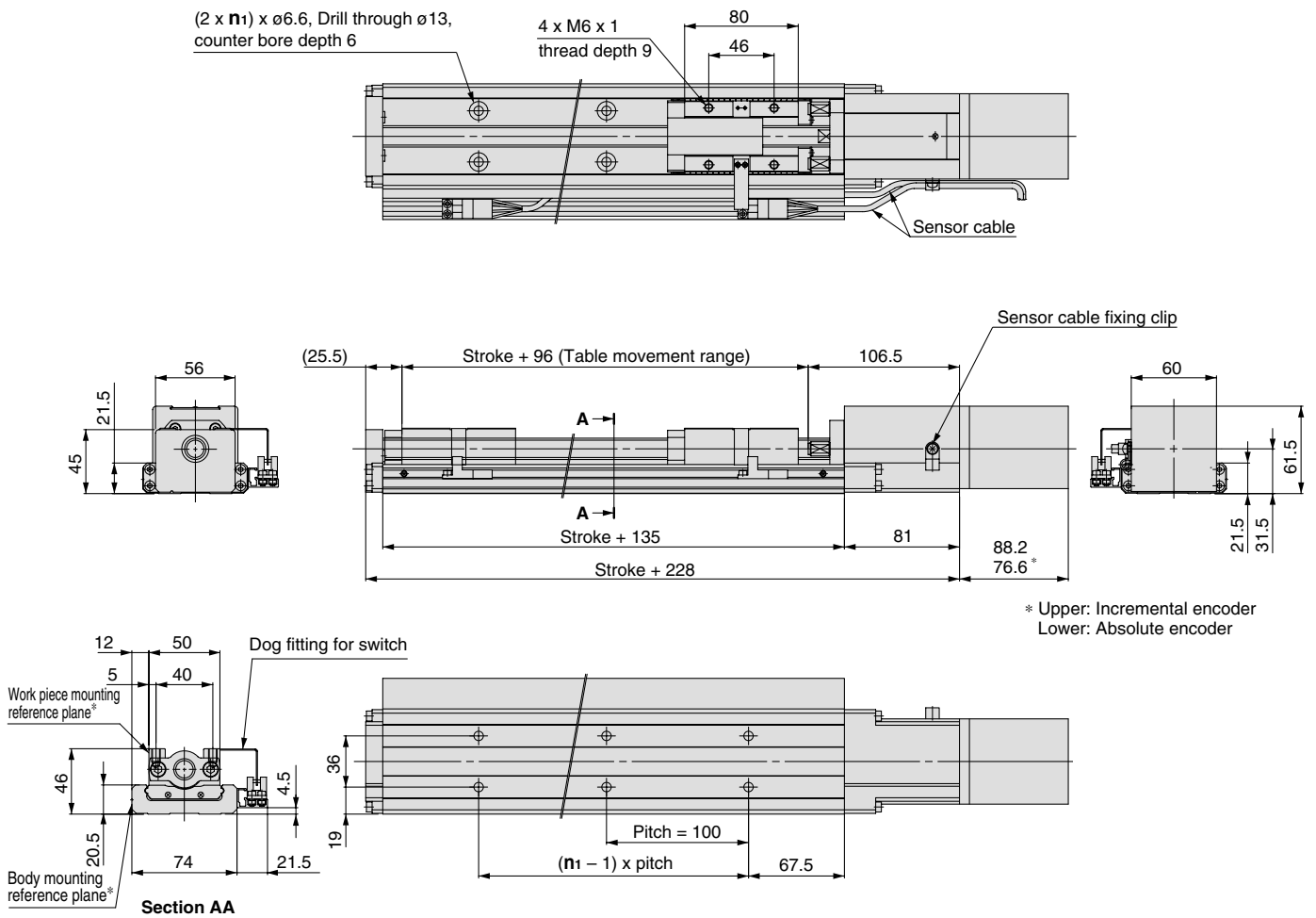

Model	Stroke	n ₁
LTF8□NH- 100-□	100	2
LTF8□NH- 200-□	200	3
LTF8□NH- 300-□	300	4
LTF8□NH- 400-□	400	5
LTF8□NH- 500-□	500	6
LTF8□NH- 600-□	600	7
LTF8□NH- 700-□	700	8
LTF8□NH- 800-□	800	9
LTF8□NH- 900-□	900	10
LTF8□NH-1000-□	1000	11

* The body mounting reference plane and work piece mounting reference plane should be used as standards when mounting onto equipment. Refer to page 93 for mounting.

Positioning Time Guide

		Positioning time (sec.)				
		1	10	100	500	1000
Speed (mm/s)	10	0.6	1.6	10.6	50.6	100.6
	100	0.6	0.7	1.6	5.6	10.6
	250	0.6	0.7	1.0	2.6	4.6
	500	0.6	0.7	0.9	1.7	2.7

* Values will vary slightly depending on the operating conditions.

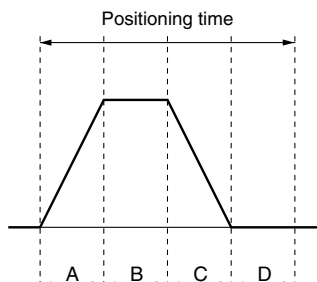

A: Acceleration time
B: Constant velocity time
C: Deceleration time
D: Resting time (0.5 sec.)
Maximum acceleration: 3000 mm/s²

Standard Motor Horizontal Mount Series LTF8

Motor Output
200 W

Rolled Ball Screw
∅15 mm/20 mm lead

How to Order

LTF8 S3 NL - 300 - R R 2 A1

Motor type

S3	AC servo motor (Incremental encoder) 200 W
S7	AC servo motor (Absolute encoder) 200 W

Stroke (mm)
Refer to the standard stroke.

Cable type

Nil	Without cable
S	Standard cable
R	Robotic cable (flexible cable)

Cable length

Nil	Without cable
2	2 m
5	5 m
A	10 m

IO connector

Nil	None
H	With IO connector

Photo micro switch

Nil	Without switch/mounting rail
1	NPN 1pc.
2	NPN 2pcs.
3	NPN 3pcs.
4	PNP 2pcs.
5	PNP 2pcs.
6	PNP 3pc.
A	Mounting rail

Driver type

Nil	Without driver
A1	Pulse input type (Incremental encoder) 100 V
A2	Pulse input type (Incremental encoder) 200 V
B1	Pulse input type (Absolute encoder) 100 V
B2	Pulse input type (Absolute encoder) 200 V

Cable entry direction

Nil	Without cable
R	Right
L	Left

Motor/switch entry direction

Specifications

		100	200	300	400	500	600	700	800	900	1000	
Performance	Standard stroke (mm)											
	Body weight (kg)	4.6	5.5	6.3	7.1	8.0	8.8	9.6	10.5	11.3	12.1	
	Operating temperature range (°C)	5 to 40 (No condensation)										
	Work load (kg)	25										
	Maximum speed (mm/s)	1000						890	710	580	480	
Main parts	Positioning repeatability (mm)	±0.05										
	Motor	AC servo motor (200 W)										
	Encoder	Incremental system/Absolute type										
	Lead screw	Rolled ball screw ∅15 mm, 20 mm lead										
	Guide	Frame-type linear guide										
Switch	Motor/Screw connection	With coupling										
	Model	Photo micro sensor EE-SX674 (Refer to page 95 for details.)										
Driver	Model	LECS□□-□ (Refer to page 97 for details.)										

Allowable Moment (N·m)

Allowable dynamic moment

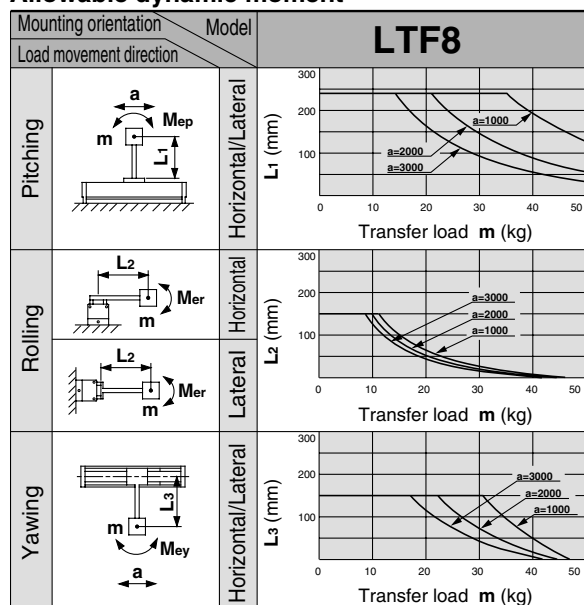

Investigation of the regeneration option

Depending on the conditions (speed, addition-subtraction speed, down time, load, etc.), the regeneration option may be required. The results of consideration in each case of maximum load or half load for the product specification are below. Please consult SMC when considering the necessity of the regeneration option.

Maximum load

Driver type	Regeneration option model
A1	Not required.
A2	Not required.
B1	Not required.
B2	Not required.

Half load

Driver type	Regeneration option model
A1	Not required.
A2	Not required.
B1	Not required.
B2	Not required.

Dimensions/LTF8□NL

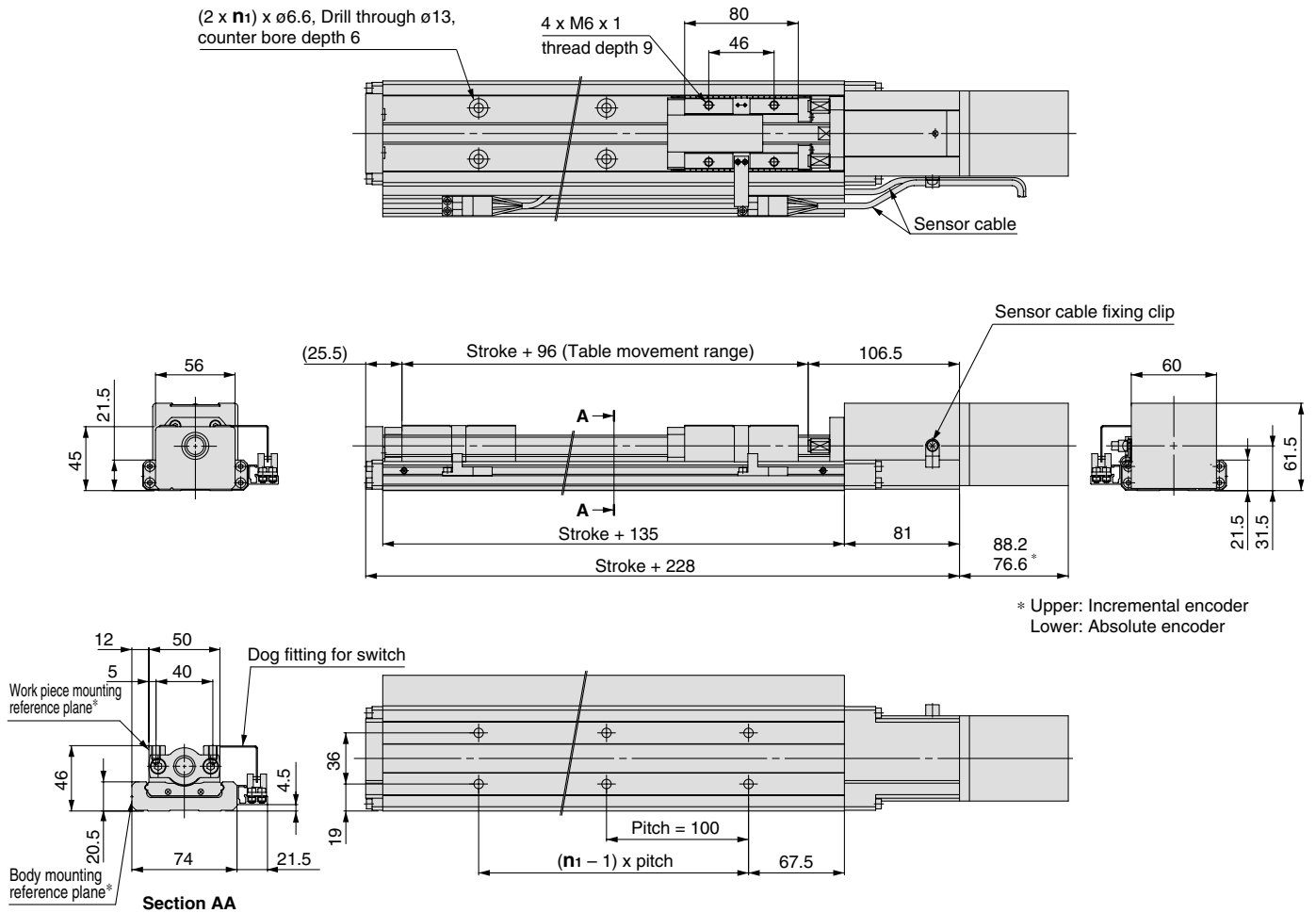

Model	Stroke	n ₁
LTF8□NL- 100-□	100	2
LTF8□NL- 200-□	200	3
LTF8□NL- 300-□	300	4
LTF8□NL- 400-□	400	5
LTF8□NL- 500-□	500	6
LTF8□NL- 600-□	600	7
LTF8□NL- 700-□	700	8
LTF8□NL- 800-□	800	9
LTF8□NL- 900-□	900	10
LTF8□NL-1000-□	1000	11

* The body mounting reference plane and work piece mounting reference plane should be used as standards when mounting onto equipment. Refer to page 93 for mounting.

Positioning Time Guide

		Positioning time (sec.)				
		1	10	100	500	1000
Speed (mm/s)	10	0.6	1.6	10.6	50.6	100.6
	100	0.6	0.7	1.6	5.6	10.6
	500	0.6	0.7	0.9	1.7	2.7
	1000	0.6	0.7	0.9	1.4	1.9

* Values will vary slightly depending on the operating conditions.

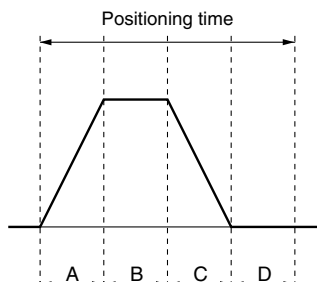

A: Acceleration time
B: Constant velocity time
C: Deceleration time
D: Resting time (0.5 sec.)
Maximum acceleration: 3000 mm/s²

Standard Motor Vertical Mount Series LTF6

Motor Output
100 W

Ground Ball Screw
∅10 mm/6 mm lead

How to Order

LTF6 S2 PF - 300 K - R R 2 A1

Motor type

S2	AC servo motor (Incremental encoder) 100 W
S6	AC servo motor (Absolute encoder) 100 W

Stroke (mm)
Refer to the standard stroke.

Cable type

Nil	Without cable
S	Standard cable
R	Robotic cable (flexible cable)

Cable length

Nil	Without cable
2	2 m
5	5 m
A	10 m

IO connector

Nil	None
H	With IO connector

Photo micro switch

Nil	Without switch/mounting rail
1	NPN 1pc.
2	NPN 2pcs.
3	NPN 3pcs.
4	PNP 1pc.
5	PNP 2pcs.
6	PNP 3pcs.
A	Mounting rail

Driver type

Nil	Without driver
A1	Pulse input type (Incremental encoder) 100 V
A2	Pulse input type (Incremental encoder) 200 V
B1	Pulse input type (Absolute encoder) 100 V
B2	Pulse input type (Absolute encoder) 200 V

Cable entry direction

Nil	Without cable
R	Right
L	Left

Left entry
Right entry
Motor/switch entry direction

Specifications

Standard stroke (mm)		100	200	300	400	500	600
Performance	Body weight (kg)	2.4	2.9	3.4	3.9	4.4	4.9
	Operating temperature range (°C)	5 to 40 (No condensation)					
	Work load (kg)	6					
	Maximum speed (mm/s)	300					
	Positioning repeatability (mm)	±0.02					
Main parts	Motor	AC servo motor (100 W) with lock					
	Encoder	Incremental system/Absolute type					
	Lead screw	Ground ball screw ∅10 mm, 6 mm lead					
	Guide	Frame-type linear guide					
	Motor/Screw connection	With coupling					
Switch	Model	Photo micro sensor EE-SX674 (Refer to page 95 for details.)					
Driver	Model	LECS□□-□ (Refer to page 97 for details.)					

Note) When using this product, the regeneration option may be required.

Allowable Moment (N·m)

Allowable dynamic moment

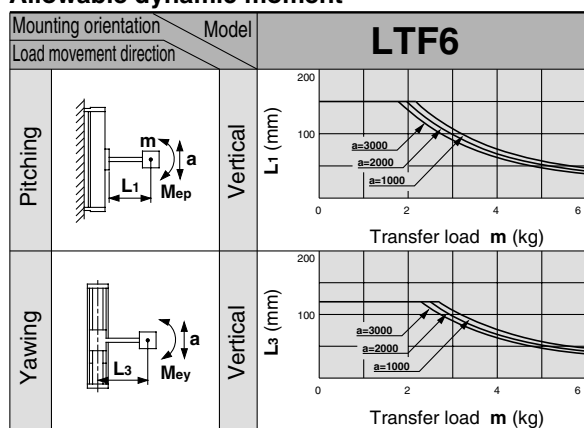

m : Transfer load (kg) M_e : Allowable dynamic moment
a : Work piece acceleration (mm/s²) L : Overhang to work piece center of gravity (mm)

Refer to page 94 for deflection data.

Investigation of the regeneration option

Depending on the conditions (speed, addition-subtraction speed, down time, load, etc.), the regeneration option may be required. The results of consideration in each case of maximum load or half load for the product specification are below. Please consult SMC when considering the necessity of the regeneration option.

Maximum load

Driver type	Regeneration option model
A1	LEC-MR-RB-032
A2	LEC-MR-RB-032
B1	LEC-MR-RB-032
B2	LEC-MR-RB-032

Half load

Driver type	Regeneration option model
A1	LEC-MR-RB-032
A2	LEC-MR-RB-032
B1	LEC-MR-RB-032
B2	LEC-MR-RB-032

Dimensions/LTF6□PF

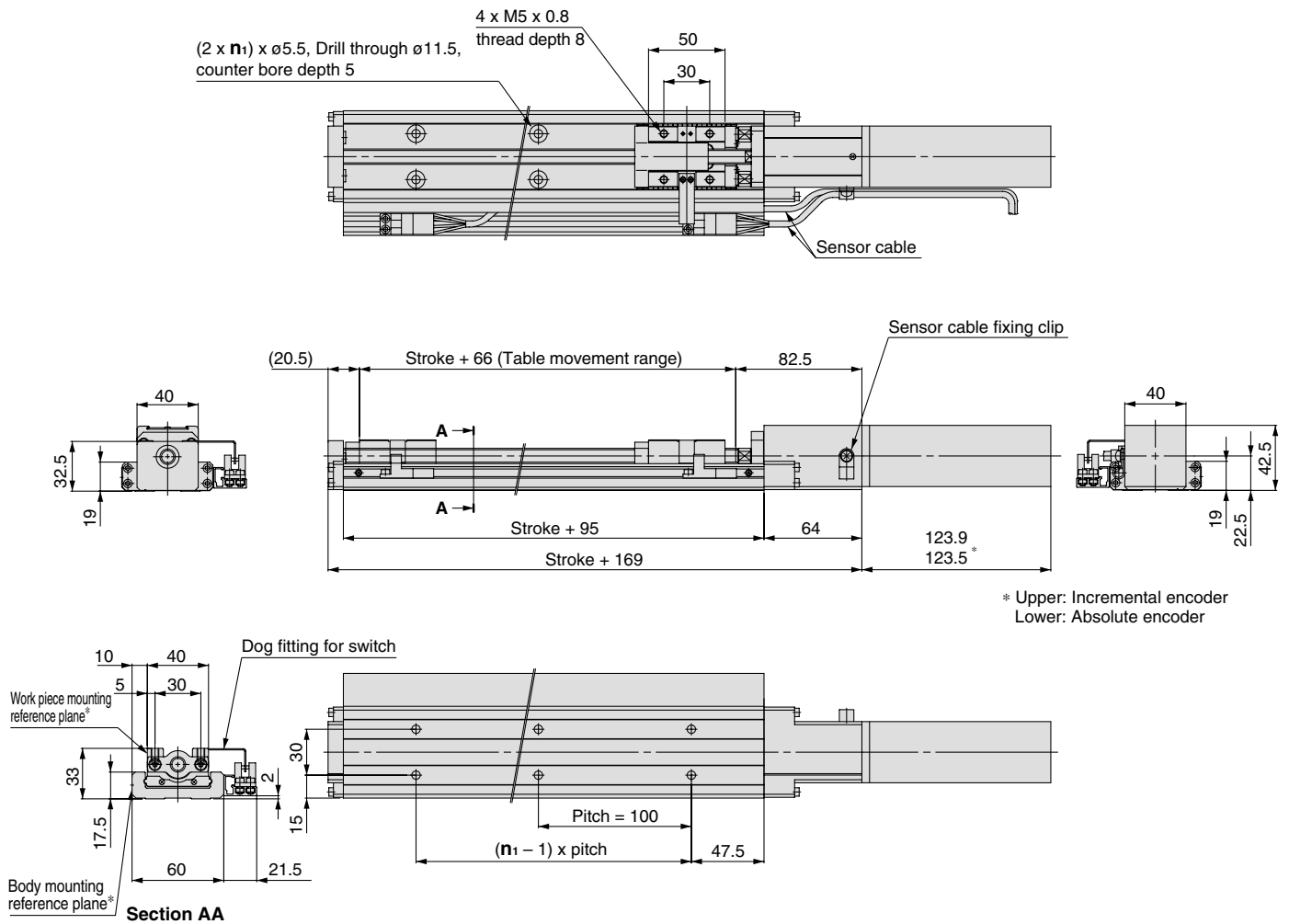

Model	Stroke	n ₁
LTF6□PF-100K-□	100	2
LTF6□PF-200K-□	200	3
LTF6□PF-300K-□	300	4
LTF6□PF-400K-□	400	5
LTF6□PF-500K-□	500	6
LTF6□PF-600K-□	600	7

* The body mounting reference plane and work piece mounting reference plane should be used as standards when mounting onto equipment. Refer to page 93 for mounting.

Positioning Time Guide

		Positioning time (sec.)				
		1	10	100	300	600
Speed (mm/s)	10	0.5	1.5	10.5	30.5	60.5
	100	0.5	0.6	1.5	3.5	6.5
	150	0.5	0.6	1.2	2.5	4.5
	300	0.5	0.6	0.9	1.6	2.6

* Values will vary slightly depending on the operating conditions.

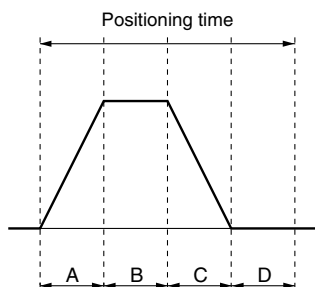

A: Acceleration time
B: Constant velocity time
C: Deceleration time
D: Resting time (0.4 sec.)
Maximum acceleration: 3000 mm/s²

Standard Motor Vertical Mount Series LTF6

Motor Output
100 W

Ground Ball Screw
∅ 10 mm/10 mm lead

How to Order

LTF6 S2 PH - 300 K - R R 2 A1

Motor type

S2	AC servo motor (Incremental encoder) 100 W
S6	AC servo motor (Absolute encoder) 100 W

Stroke (mm)
Refer to the standard stroke.

Cable type

Nil	Without cable
S	Standard cable
R	Robotic cable (flexible cable)

Cable entry direction

Nil	Without cable
R	Right
L	Left

Cable length

Nil	Without cable
2	2 m
5	5 m
A	10 m

IO connector

Nil	None
H	With IO connector

Photo micro switch

Nil	Without switch/mounting rail
1	NPN 1pc.
2	NPN 2pcs.
3	NPN 3pcs.
4	PNP 1pc.
5	PNP 2pcs.
6	PNP 3pcs.
A	Mounting rail

Driver type

Nil	Without driver
A1	Pulse input type (Incremental encoder) 100 V
A2	Pulse input type (Incremental encoder) 200 V
B1	Pulse input type (Absolute encoder) 100 V
B2	Pulse input type (Absolute encoder) 200 V

Left entry
Right entry
Motor/switch entry direction

Specifications

Standard stroke (mm)		100	200	300	400	500	600
Performance	Body weight (kg)	2.4	2.9	3.4	3.9	4.4	4.9
	Operating temperature range (°C)	5 to 40 (No condensation)					
	Work load (kg)	3					
	Maximum speed (mm/s)	500					390
	Positioning repeatability (mm)	±0.02					
Main parts	Motor	AC servo motor (100 W) with lock					
	Encoder	Incremental system/Absolute type					
	Lead screw	Ground ball screw ∅10 mm, 10 mm lead					
	Guide	Frame-type linear guide					
	Motor/Screw connection	With coupling					
Switch	Model	Photo micro sensor EE-SX674 (Refer to page 95 for details.)					
Driver	Model	LECS□□□□ (Refer to page 97 for details.)					

Note) When using this product, the regeneration option may be required.

Allowable Moment (N·m)

Allowable dynamic moment

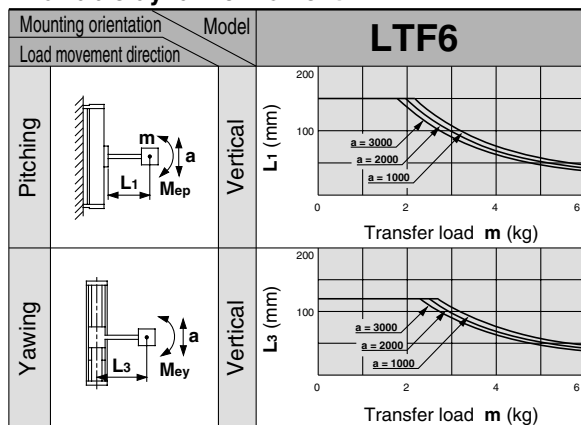

m : Transfer load (kg) M_e : Allowable dynamic moment
 a : Work piece acceleration (mm/s²) L : Overhang to work piece center of gravity (mm)

Refer to page 94 for deflection data.

Investigation of the regeneration option

Depending on the conditions (speed, addition-subtraction speed, down time, load, etc.), the regeneration option may be required. The results of consideration in each case of maximum load or half load for the product specification are below. Please consult SMC when considering the necessity of the regeneration option.

Maximum load

Driver type	Regeneration option model
A1	LEC-MR-RB-032
A2	LEC-MR-RB-032
B1	LEC-MR-RB-032
B2	LEC-MR-RB-032

Half load

Driver type	Regeneration option model
A1	Not required.
A2	Not required.
B1	Not required.
B2	Not required.

Dimensions/LTF6□PH

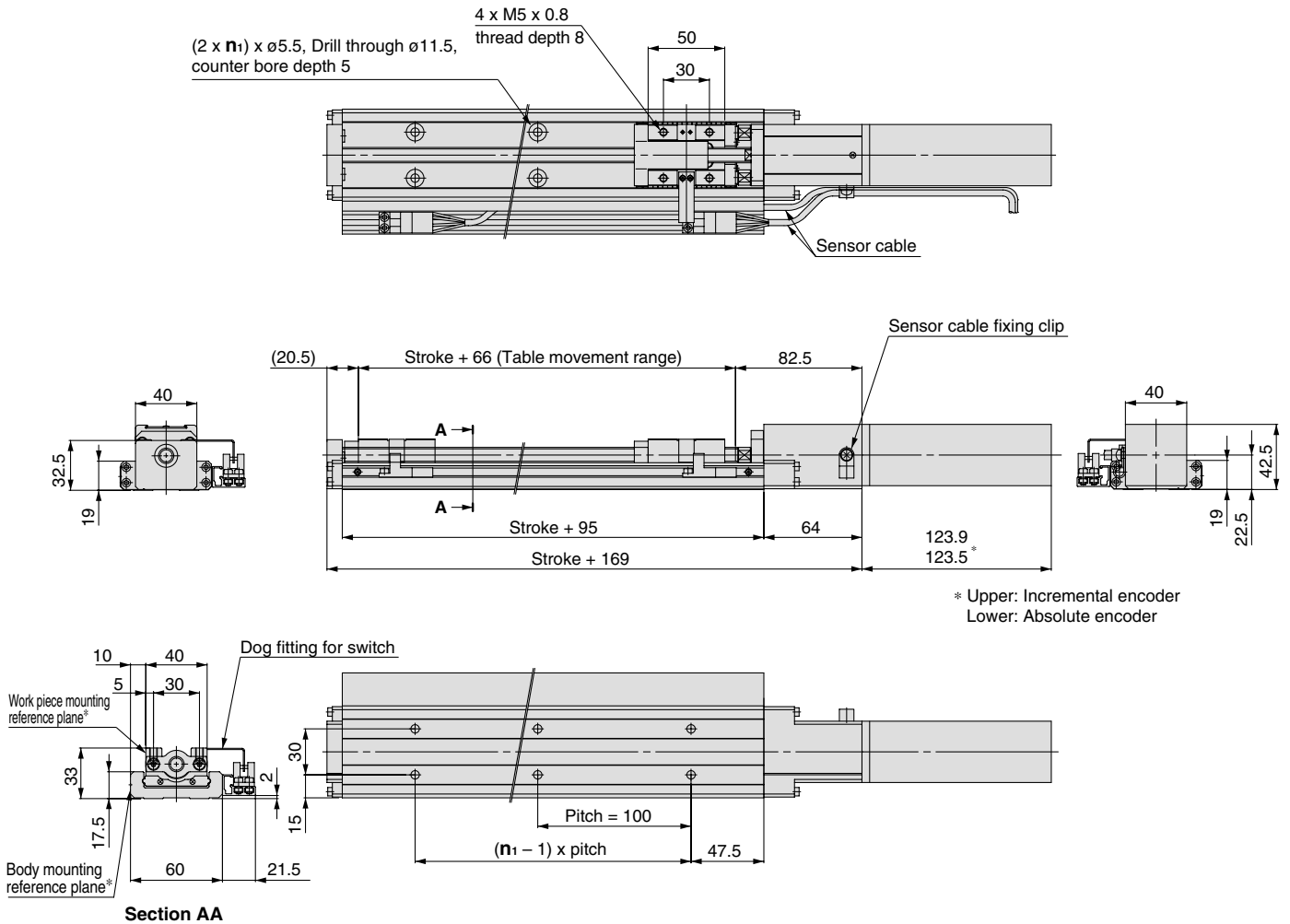

Model	Stroke	n ₁
LTF6□PH-100K-□	100	2
LTF6□PH-200K-□	200	3
LTF6□PH-300K-□	300	4
LTF6□PH-400K-□	400	5
LTF6□PH-500K-□	500	6
LTF6□PH-600K-□	600	7

* The body mounting reference plane and work piece mounting reference plane should be used as standards when mounting onto equipment. Refer to page 93 for mounting.

Positioning Time Guide

		Positioning time (sec.)				
		1	10	100	300	600
Speed (mm/s)	10	0.5	1.5	10.5	30.5	60.5
	100	0.5	0.6	1.5	3.5	6.5
	250	0.5	0.6	0.9	1.7	2.9
	500	0.5	0.6	0.8	1.2	1.8

* Values will vary slightly depending on the operating conditions.

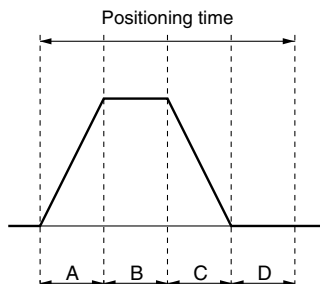

A: Acceleration time
 B: Constant velocity time
 C: Deceleration time
 D: Resting time (0.4 sec.)
 Maximum acceleration: 3000 mm/s²

Standard Motor Vertical Mount Series LTF6

Motor Output
100 W

Rolled Ball Screw
∅10 mm/6 mm lead

How to Order

LTF6 S2 NF - 300 K - R R 2 A1

Motor type

S2	AC servo motor (Incremental encoder) 100 W
S6	AC servo motor (Absolute encoder) 100 W

Stroke (mm)
Refer to the standard stroke.

Cable type

Nil	Without cable
S	Standard cable
R	Robotic cable (flexible cable)

Cable length

Nil	Without cable
2	2 m
5	5 m
A	10 m

IO connector

Nil	None
H	With IO connector

Photo micro switch

Nil	Without switch/mounting rail
1	NPN 1pc.
2	NPN 2pcs.
3	NPN 3pcs.
4	PNP 1pc.
5	PNP 2pcs.
6	PNP 3pcs.
A	Mounting rail

Driver type

Nil	Without driver
A1	Pulse input type (Incremental encoder) 100 V
A2	Pulse input type (Incremental encoder) 200 V
B1	Pulse input type (Absolute encoder) 100 V
B2	Pulse input type (Absolute encoder) 200 V

Cable entry direction

Nil	Without cable
R	Right
L	Left

Specifications

Standard stroke (mm)		100	200	300	400	500	600
Performance	Body weight (kg)	2.4	2.9	3.4	3.9	4.4	4.9
	Operating temperature range (°C)	5 to 40 (No condensation)					
	Work load (kg)	6					
	Maximum speed (mm/s)	300					
	Positioning repeatability (mm)	±0.05					
Main parts	Motor	AC servo motor (100 W) with lock					
	Encoder	Incremental system/Absolute type					
	Lead screw	Rolled ball screw ∅10 mm, 6 mm lead					
	Guide	Frame-type linear guide					
	Motor/Screw connection	With coupling					
Switch	Model	Photo micro sensor EE-SX674 (Refer to page 95 for details.)					
Driver	Model	LECS□□□□ (Refer to page 97 for details.)					

Note) When using this product, the regeneration option may be required.

Allowable Moment (N·m)

Allowable dynamic moment

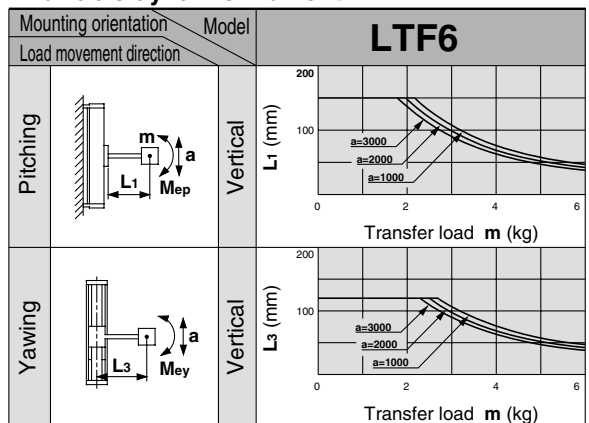

m : Transfer load (kg) M_e : Allowable dynamic moment
 a : Work piece acceleration (mm/s²) L : Overhang to work piece center of gravity (mm)

Refer to page 94 for deflection data.

Investigation of the regeneration option

Depending on the conditions (speed, addition-subtraction speed, down time, load, etc.), the regeneration option may be required. The results of consideration in each case of maximum load or half load for the product specification are below. Please consult SMC when considering the necessity of the regeneration option.

Maximum load

Driver type	Regeneration option model
A1	LEC-MR-RB-032
A2	LEC-MR-RB-032
B1	LEC-MR-RB-032
B2	LEC-MR-RB-032

Half load

Driver type	Regeneration option model
A1	LEC-MR-RB-032
A2	LEC-MR-RB-032
B1	LEC-MR-RB-032
B2	LEC-MR-RB-032

Dimensions/LTF6□NF

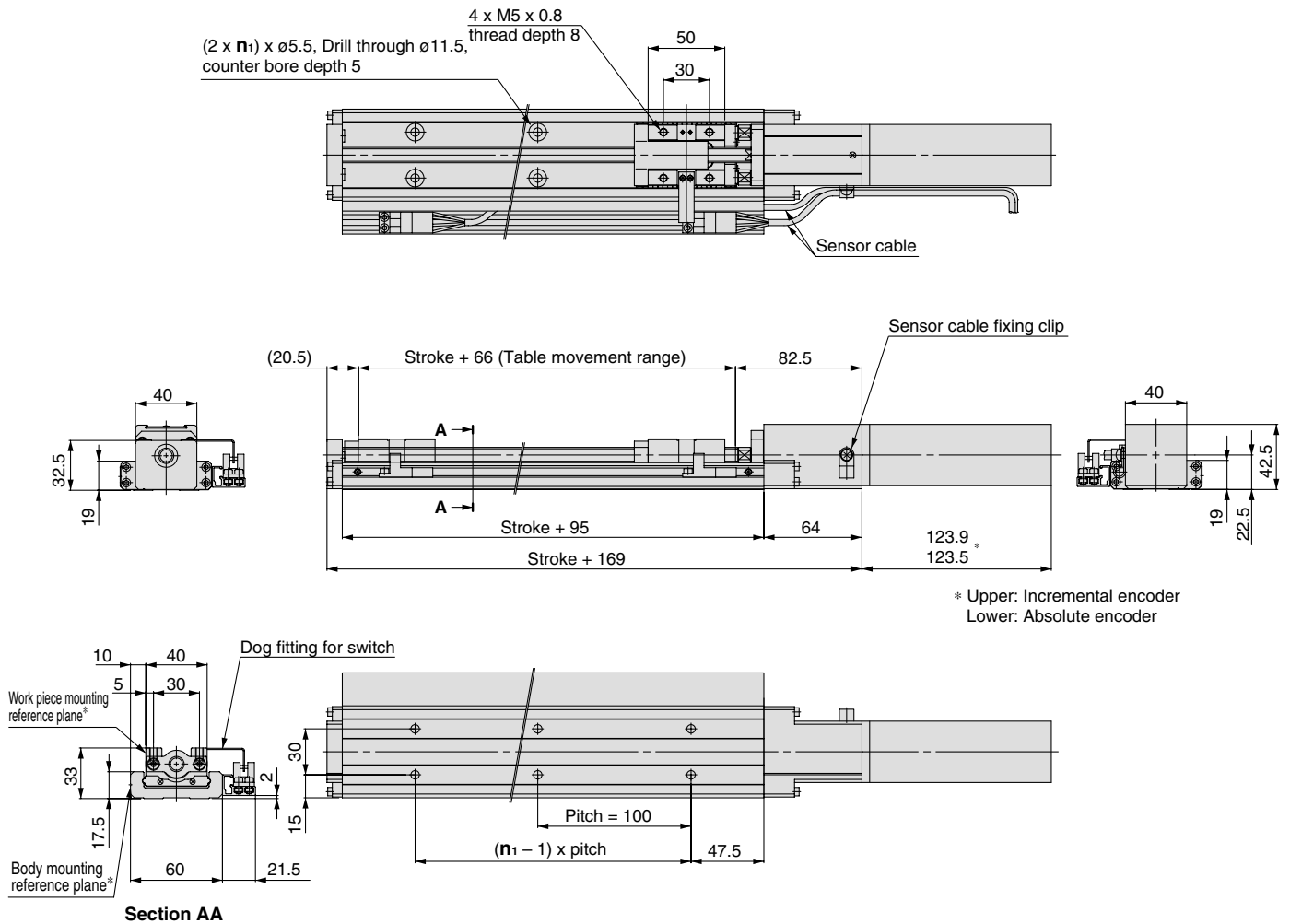

Model	Stroke	n ₁
LTF6□NF-100K-□	100	2
LTF6□NF-200K-□	200	3
LTF6□NF-300K-□	300	4
LTF6□NF-400K-□	400	5
LTF6□NF-500K-□	500	6
LTF6□NF-600K-□	600	7

* The body mounting reference plane and work piece mounting reference plane should be used as standards when mounting onto equipment. Refer to page 93 for mounting.

Positioning Time Guide

		Positioning time (sec.)				
		1	10	100	300	600
Speed (mm/s)	10	0.5	1.5	10.5	30.5	60.5
	100	0.5	0.6	1.5	3.5	6.5
	150	0.5	0.6	1.2	2.5	4.5
	300	0.5	0.6	0.9	1.6	2.6

* Values will vary slightly depending on the operating conditions.

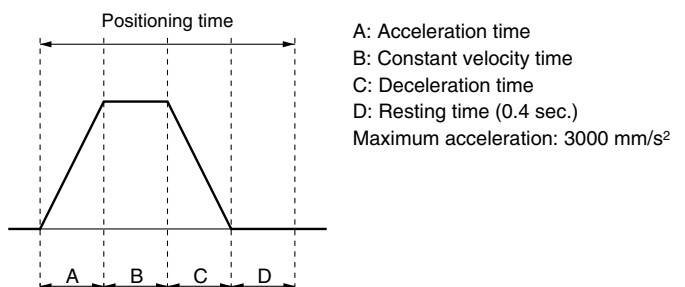

Standard Motor Vertical Mount Series LTF6

Motor Output
100 W

Rolled Ball Screw
∅ 10 mm/10 mm lead

How to Order

LTF6 S2 NH - 300 K - R R 2 A1

Motor type

S2	AC servo motor (Incremental encoder) 100 W
S6	AC servo motor (Absolute encoder) 100 W

Stroke (mm)
Refer to the standard stroke.

Cable type

Nil	Without cable
S	Standard cable
R	Robotic cable (flexible cable)

Cable length

Nil	Without cable
2	2 m
5	5 m
A	10 m

IO connector

Nil	None
H	With IO connector

Photo micro switch

Nil	Without switch/mounting rail
1	NPN 1pc.
2	NPN 2pcs.
3	NPN 3pcs.
4	PNP 1pc.
5	PNP 2pcs.
6	PNP 3pcs.
A	Mounting rail

Driver type

Nil	Without driver
A1	Pulse input type (Incremental encoder) 100 V
A2	Pulse input type (Incremental encoder) 200 V
B1	Pulse input type (Absolute encoder) 100 V
B2	Pulse input type (Absolute encoder) 200 V

Cable entry direction

Nil	Without cable
R	Right
L	Left

Specifications

Standard stroke (mm)		100	200	300	400	500	600
Performance	Body weight (kg)	2.4	2.9	3.4	3.9	4.4	4.9
	Operating temperature range (°C)	5 to 40 (No condensation)					
	Work load (kg)	3					
	Maximum speed (mm/s)	500					
	Positioning repeatability (mm)	±0.05					
Main parts	Motor	AC servo motor (100 W) with lock					
	Encoder	Incremental system/Absolute type					
	Lead screw	Rolled ball screw ∅10 mm, 10 mm lead					
	Guide	Frame-type linear guide					
	Motor/Screw connection	With coupling					
Switch	Model	Photo micro sensor EE-SX674 (Refer to page 95 for details.)					
Driver	Model	LECS□□□□ (Refer to page 97 for details.)					

Note) When using this product, the regeneration option may be required.

Allowable Moment (N·m)

Allowable dynamic moment

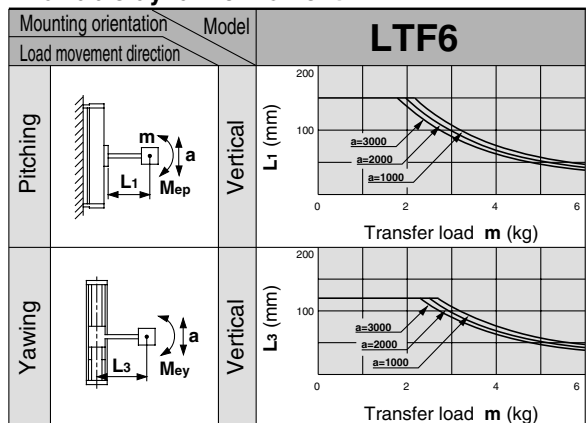

m : Transfer load (kg) M_e : Allowable dynamic moment
 a : Work piece acceleration (mm/s²) L : Overhang to work piece center of gravity (mm)

Refer to page 94 for deflection data.

Investigation of the regeneration option

Depending on the conditions (speed, addition-subtraction speed, down time, load, etc.), the regeneration option may be required. The results of consideration in each case of maximum load or half load for the product specification are below. Please consult SMC when considering the necessity of the regeneration option.

Maximum load

Driver type	Regeneration option model
A1	LEC-MR-RB-032
A2	LEC-MR-RB-032
B1	LEC-MR-RB-032
B2	LEC-MR-RB-032

Half load

Driver type	Regeneration option model
A1	Not required.
A2	Not required.
B1	Not required.
B2	Not required.

Dimensions/LTF6□NH

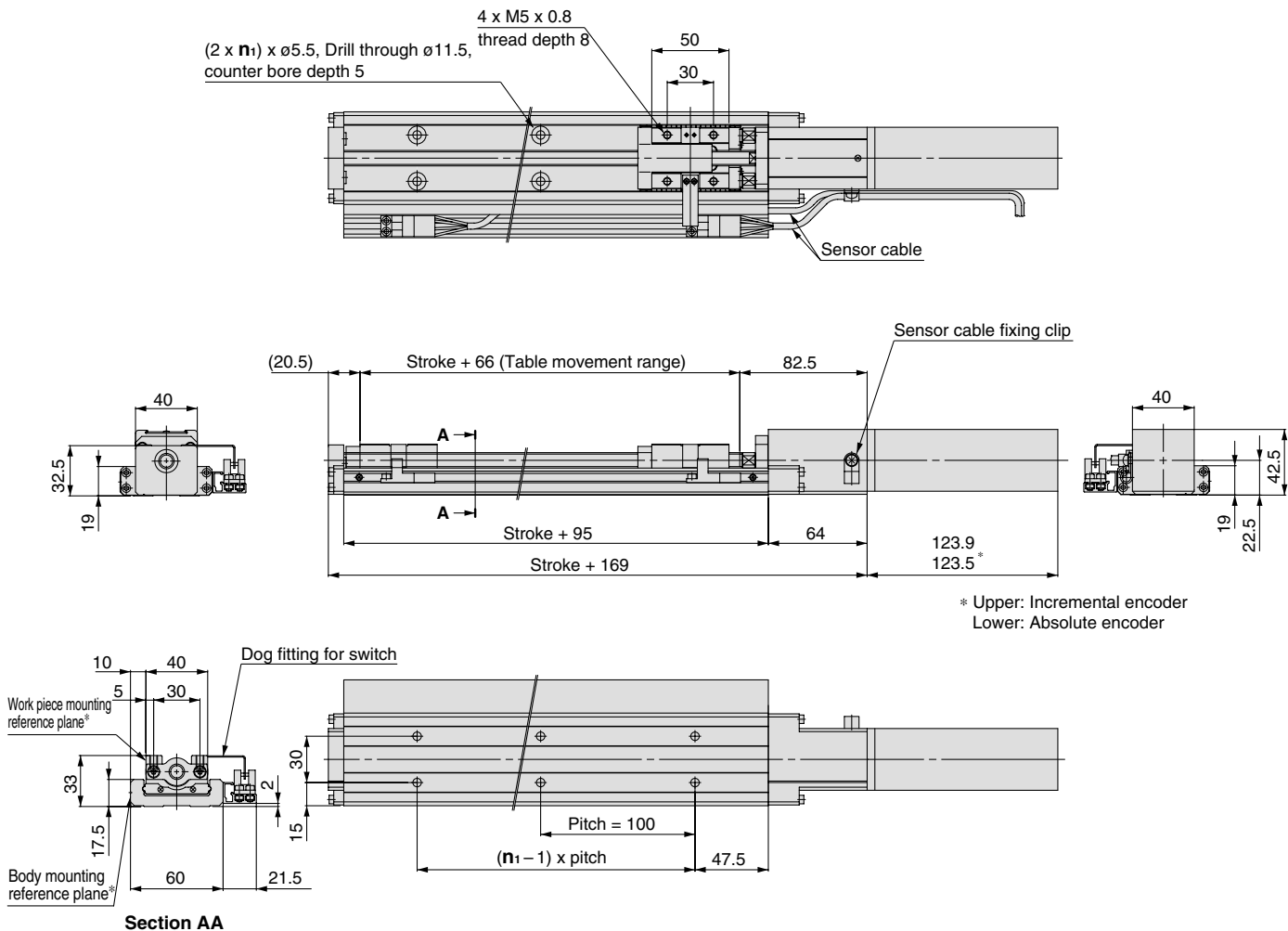

Model	Stroke	n_1
LTF6□NH-100K-□	100	2
LTF6□NH-200K-□	200	3
LTF6□NH-300K-□	300	4
LTF6□NH-400K-□	400	5
LTF6□NH-500K-□	500	6
LTF6□NH-600K-□	600	7

* The body mounting reference plane and work piece mounting reference plane should be used as standards when mounting onto equipment. Refer to page 93 for mounting.

Positioning Time Guide

		Positioning time (sec.)				
		1	10	100	300	600
Speed (mm/s)	10	0.5	1.5	10.5	30.5	60.5
	100	0.5	0.6	1.5	3.5	6.5
	250	0.5	0.6	0.9	1.7	2.9
	500	0.5	0.6	0.8	1.2	1.8

* Values will vary slightly depending on the operating conditions.

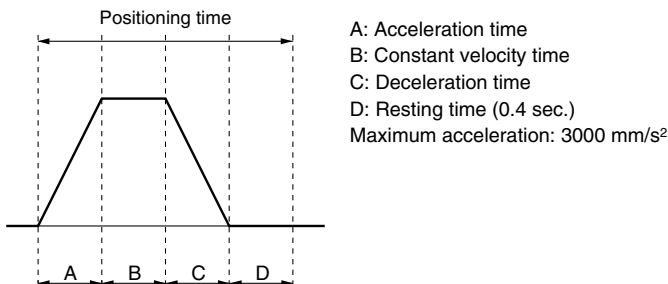

Standard Motor Vertical Mount Series LTF8

Motor Output
200 W

Ground Ball Screw
∅15 mm/10 mm lead

How to Order

LTF8 S3 PH - 300 K - R R 2 A1

Motor type

S3	AC servo motor (Incremental encoder) 200 W
S7	AC servo motor (Absolute encoder) 200 W

Stroke (mm)
Refer to the standard stroke.

Cable type

Nil	Without cable
S	Standard cable
R	Robotic cable (flexible cable)

Cable length

Nil	Without cable
2	2 m
5	5 m
A	10 m

IO connector

Nil	None
H	With IO connector

Photo micro switch

Nil	Without switch/mounting rail
1	NPN 1pc.
2	NPN 2pcs.
3	NPN 3pcs.
4	PNP 1pc.
5	PNP 2pcs.
6	PNP 3pcs.
A	Mounting rail

Driver type

Nil	Without driver
A1	Pulse input type (Incremental encoder) 100 V
A2	Pulse input type (Incremental encoder) 200 V
B1	Pulse input type (Absolute encoder) 100 V
B2	Pulse input type (Absolute encoder) 200 V

Cable entry direction

Nil	Without cable
R	Right
L	Left

Left entry
Right entry
Motor/switch entry direction

Specifications

Standard stroke (mm)		100	200	300	400	500	600	700	800	900	1000
Performance	Body weight (kg)	5.0	5.9	6.7	7.5	8.4	9.2	10.0	10.9	11.7	12.5
	Operating temperature range (°C)	5 to 40 (No condensation)									
	Work load (kg)	10									
	Maximum speed (mm/s)	500						440	350	290	240
	Positioning repeatability (mm)	±0.02									
Main parts	Motor	AC servo motor (200 W) with lock									
	Encoder	Incremental system/Absolute type									
	Lead screw	Ground ball screw ∅15 mm, 10 mm lead									
	Guide	Frame-type linear guide									
	Motor/Screw connection	With coupling									
Switch	Model	Photo micro sensor EE-SX674 (Refer to page 95 for details.)									
Driver	Model	LECS□□□□(Refer to page 97 for details.)									

Note) When using this product, the regeneration option may be required.

Allowable Moment (N·m)

Allowable dynamic moment

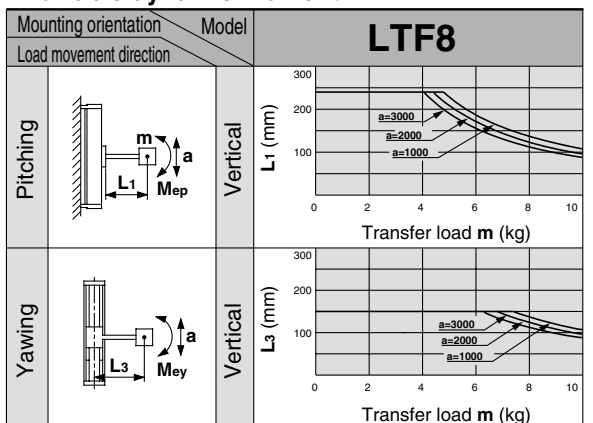

m : Transfer load (kg)
 a : Work piece acceleration (mm/s²)
 M_e : Allowable dynamic moment
 L : Overhang to work piece center of gravity (mm)

Refer to page 94 for deflection data.

Investigation of the regeneration option

Depending on the conditions (speed, addition-subtraction speed, down time, load, etc.), the regeneration option may be required. The results of consideration in each case of maximum load or half load for the product specification are below. Please consult SMC when considering the necessity of the regeneration option.

Maximum load

Driver type	Regeneration option model
A1	LEC-MR-RB-032
A2	LEC-MR-RB-032
B1	LEC-MR-RB-032
B2	LEC-MR-RB-032

Half load

Driver type	Regeneration option model
A1	LEC-MR-RB-032
A2	Not required.
B1	LEC-MR-RB-032
B2	Not required.

Dimensions/LTF8□PH

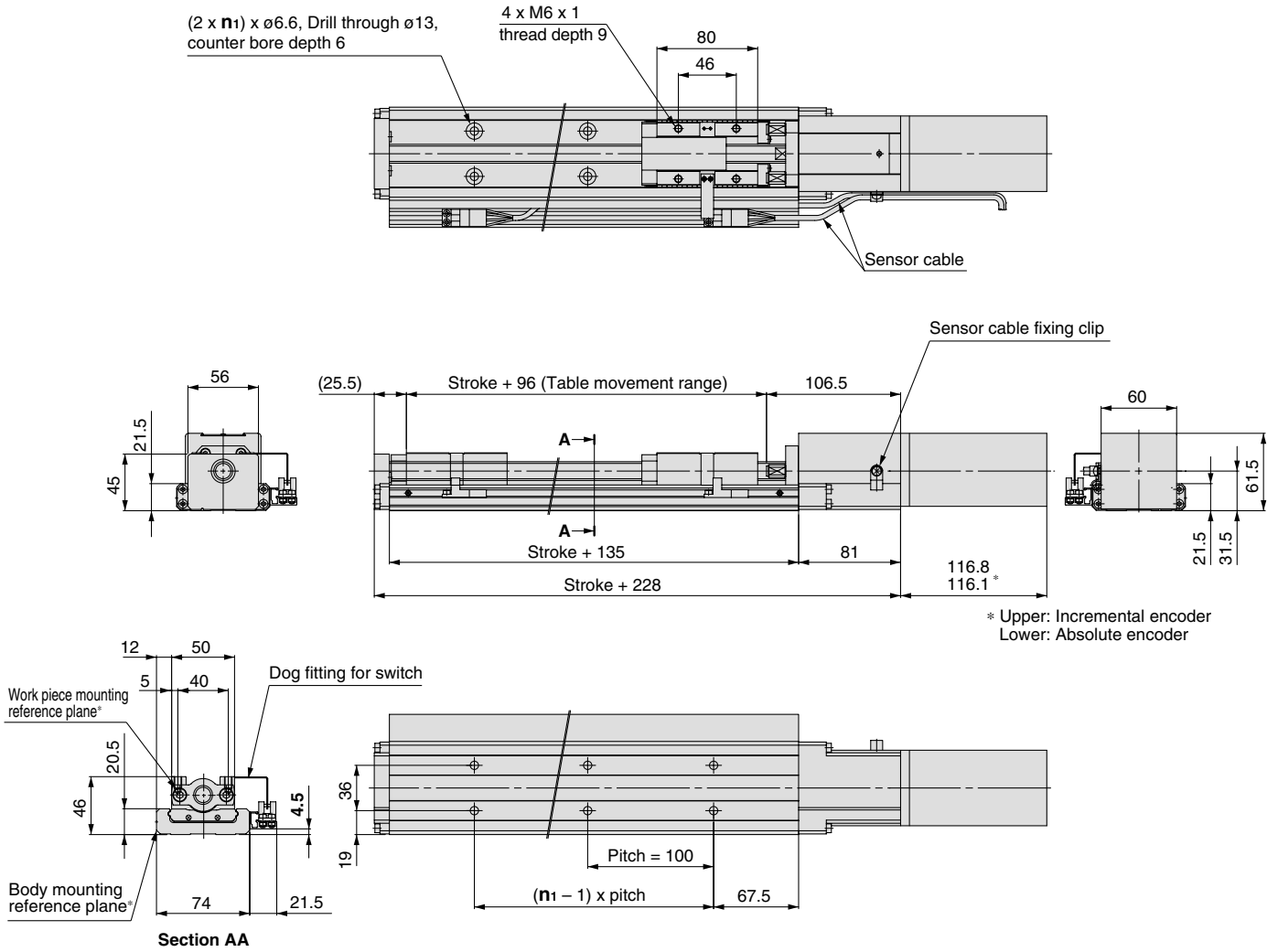

Model	Stroke	n ₁
LTF8□PH- 100K-□	100	2
LTF8□PH- 200K-□	200	3
LTF8□PH- 300K-□	300	4
LTF8□PH- 400K-□	400	5
LTF8□PH- 500K-□	500	6
LTF8□PH- 600K-□	600	7
LTF8□PH- 700K-□	700	8
LTF8□PH- 800K-□	800	9
LTF8□PH- 900K-□	900	10
LTF8□PH-1000K-□	1000	11

* The body mounting reference plane and work piece mounting reference plane should be used as standards when mounting onto equipment. Refer to page 93 for mounting.

Positioning Time Guide

		Positioning time (sec.)				
		1	10	100	500	1000
Speed (mm/s)	10	0.6	1.6	10.6	50.6	100.6
	100	0.6	0.7	1.6	5.6	10.6
	250	0.6	0.7	1.0	2.6	4.6
	500	0.6	0.7	0.9	1.7	2.7

* Values will vary slightly depending on the operating conditions.

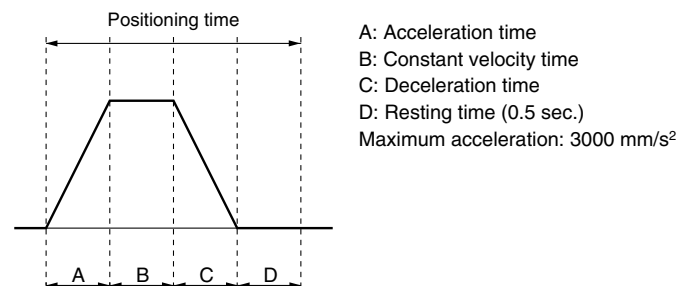

Standard Motor Vertical Mount Series LTF8

Motor Output
200 W

Ground Ball Screw
∅15 mm/20 mm lead

How to Order

LTF8 S3 PL - 300 K - R R 2 A1

Motor type

S3	AC servo motor (Incremental encoder) 200 W
S7	AC servo motor (Absolute encoder) 200 W

Stroke (mm)
Refer to the standard stroke.

Cable type

Nil	Without cable
S	Standard cable
R	Robotic cable (flexible cable)

Cable length

Nil	Without cable
2	2 m
5	5 m
A	10 m

IO connector

Nil	None
H	With IO connector

Photo micro switch

Nil	Without switch/mounting rail
1	NPN 1pc.
2	NPN 2pcs.
3	NPN 3pcs.
4	PNP 1pc.
5	PNP 2pcs.
6	PNP 3pcs.
A	Mounting rail

Driver type

Nil	Without driver
A1	Pulse input type (Incremental encoder) 100 V
A2	Pulse input type (Incremental encoder) 200 V
B1	Pulse input type (Absolute encoder) 100 V
B2	Pulse input type (Absolute encoder) 200 V

Cable entry direction

Nil	Without cable
R	Right
L	Left

Left entry
Right entry
Motor/switch entry direction

Specifications

Standard stroke (mm)		100	200	300	400	500	600	700	800	900	1000
Performance	Body weight (kg)	5.0	5.9	6.7	7.5	8.4	9.2	10.0	10.9	11.7	12.5
	Operating temperature range (°C)	5 to 40 (No condensation)									
	Work load (kg)	5									
	Maximum speed (mm/s)	1000						890	710	580	480
	Positioning repeatability (mm)	±0.02									
Main parts	Motor	AC servo motor (200 W) with lock									
	Encoder	Incremental system/Absolute type									
	Lead screw	Ground ball screw ∅15 mm, 20 mm lead									
	Guide	Frame-type linear guide									
	Motor/Screw connection	With coupling									
Switch	Model	Photo micro sensor EE-SX674 (Refer to page 95 for details.)									
Driver	Model	LECS□□-□ (Refer to page 97 for details.)									

Note) When using this product, the regeneration option may be required.

Allowable Moment (N·m)

Allowable dynamic moment

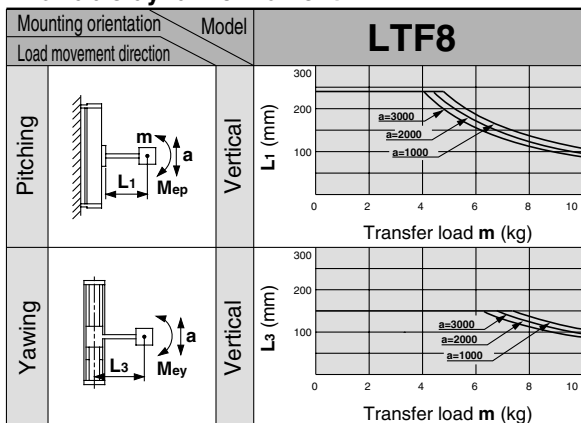

m : Transfer load (kg) M_e : Allowable dynamic moment
 a : Work piece acceleration (mm/s²) L : Overhang to work piece center of gravity (mm)
 Refer to page 94 for deflection data.

Investigation of the regeneration option

Depending on the conditions (speed, addition-subtraction speed, down time, load, etc.), the regeneration option may be required. The results of consideration in each case of maximum load or half load for the product specification are below. Please consult SMC when considering the necessity of the regeneration option.

Maximum load

Driver type	Regeneration option model
A1	LEC-MR-RB-032
A2	LEC-MR-RB-032
B1	LEC-MR-RB-032
B2	LEC-MR-RB-032

Half load

Driver type	Regeneration option model
A1	Not required.
A2	Not required.
B1	Not required.
B2	Not required.

Dimensions/LTF8□PL

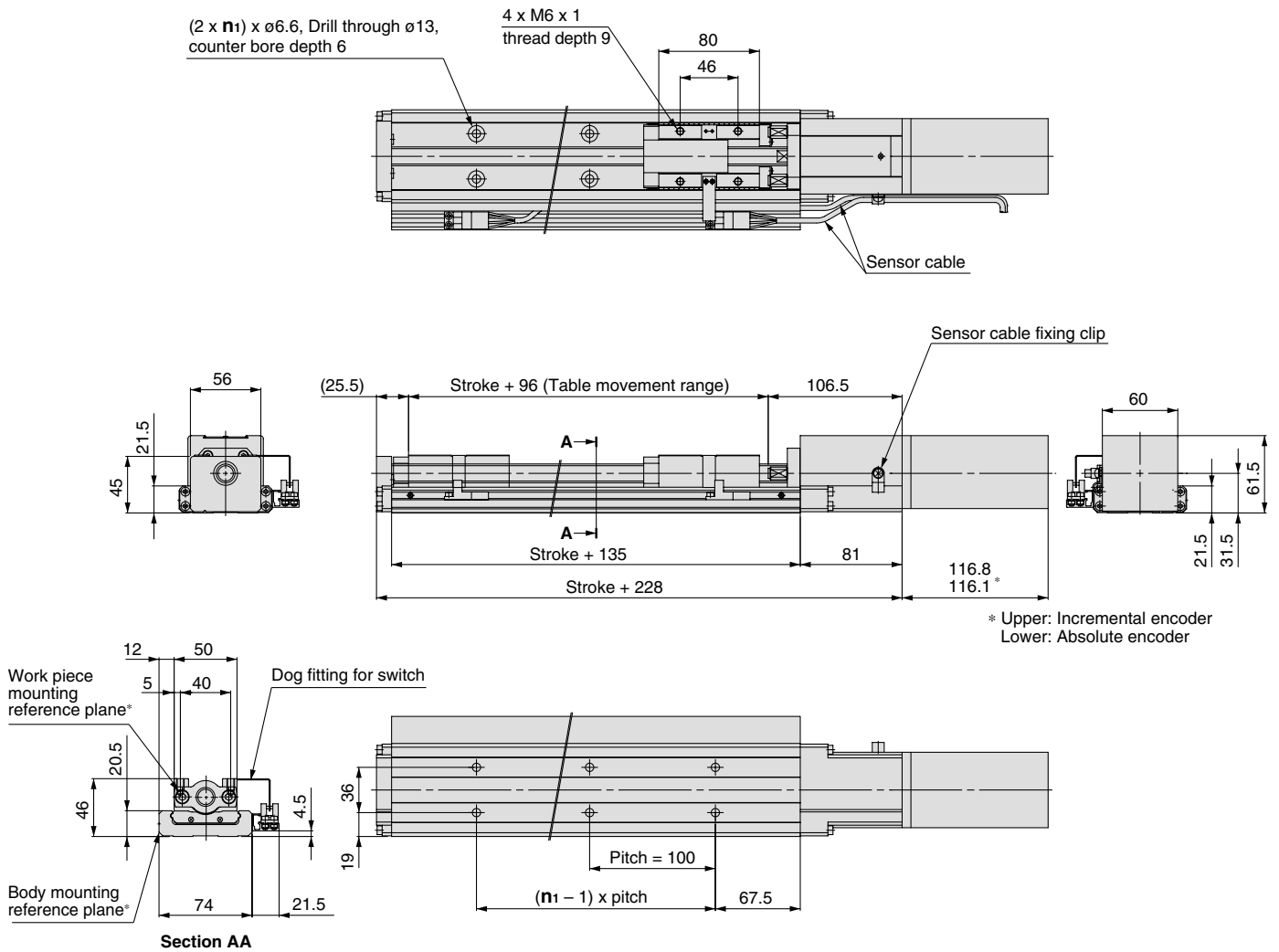

Model	Stroke	n ₁
LTF8□PL- 100K-□	100	2
LTF8□PL- 200K-□	200	3
LTF8□PL- 300K-□	300	4
LTF8□PL- 400K-□	400	5
LTF8□PL- 500K-□	500	6
LTF8□PL- 600K-□	600	7
LTF8□PL- 700K-□	700	8
LTF8□PL- 800K-□	800	9
LTF8□PL- 900K-□	900	10
LTF8□PL-1000K-□	1000	11

* The body mounting reference plane and work piece mounting reference plane should be used as standards when mounting onto equipment. Refer to page 93 for mounting.

Positioning Time Guide

		Positioning time (sec.)				
		1	10	100	500	1000
Speed (mm/s)	10	0.6	1.6	10.6	50.6	100.6
	100	0.6	0.7	1.6	5.6	10.6
	500	0.6	0.7	0.9	1.7	2.7
	1000	0.6	0.7	0.9	1.4	1.9

* Values will vary slightly depending on the operating conditions.

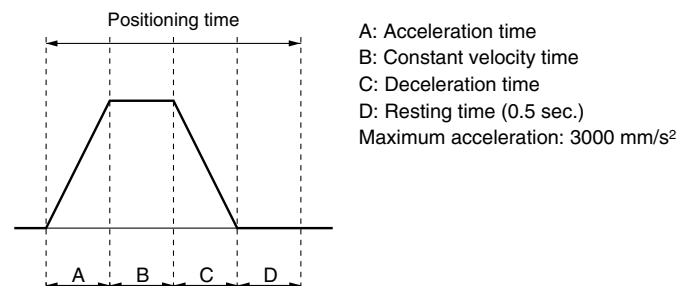

Standard Motor Vertical Mount Series LTF8

Motor Output
200 W

Rolled Ball Screw
∅15 mm/10 mm lead

How to Order

LTF8 S3 NH - 300 K - R R 2 A1

Motor type

S3	AC servo motor (Incremental encoder) 200 W
S7	AC servo motor (Absolute encoder) 200 W

Stroke (mm)
Refer to the standard stroke.

Cable type

Nil	Without cable
S	Standard cable
R	Robotic cable (flexible cable)

Cable length

Nil	Without cable
2	2 m
5	5 m
A	10 m

IO connector

Nil	None
H	With IO connector

Photo micro switch

Nil	Without switch/mounting rail
1	NPN 1pc.
2	NPN 2pcs.
3	NPN 3pcs.
4	PNP 1pc.
5	PNP 2pcs.
6	PNP 3pcs.
A	Mounting rail

Driver type

Nil	Without driver
A1	Pulse input type (Incremental encoder) 100 V
A2	Pulse input type (Incremental encoder) 200 V
B1	Pulse input type (Absolute encoder) 100 V
B2	Pulse input type (Absolute encoder) 200 V

Cable entry direction

Nil	Without cable
R	Right
L	Left

Specifications

Standard stroke (mm)		100	200	300	400	500	600	700	800	900	1000	
Performance	Body weight (kg)	5.0	5.9	6.7	7.5	8.4	9.2	10.0	10.9	11.7	12.5	
	Operating temperature range (°C)	5 to 40 (No condensation)										
	Work load (kg)	10										
	Maximum speed (mm/s)	500							440	350	290	240
	Positioning repeatability (mm)	±0.05										
Main parts	Motor	AC servo motor (200 W) with lock										
	Encoder	Incremental system/Absolute type										
	Lead screw	Rolled ball screw ∅15 mm, 10 mm lead										
	Guide	Frame-type linear guide										
	Motor/Screw connection	With coupling										
Switch	Model	Photo micro sensor EE-SX674 (Refer to page 95 for details.)										
Driver	Model	LECS□□-□ (Refer to page 97 for details.)										

Note) When using this product, the regeneration option may be required.

Allowable Moment (N·m)

Allowable dynamic moment

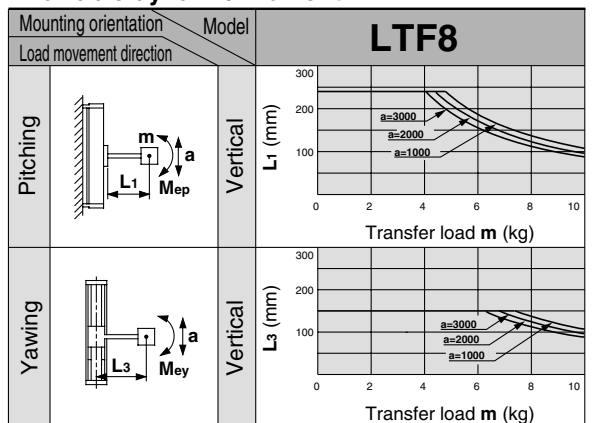

m : Transfer load (kg) Me: Allowable dynamic moment
a : Work piece acceleration (mm/s²) L : Overhang to work piece center of gravity (mm)

Refer to page 94 for deflection data.

Investigation of the regeneration option

Depending on the conditions (speed, addition-subtraction speed, down time, load, etc.), the regeneration option may be required. The results of consideration in each case of maximum load or half load for the product specification are below. Please consult SMC when considering the necessity of the regeneration option.

Maximum load

Driver type	Regeneration option model
A1	LEC-MR-RB-032
A2	LEC-MR-RB-032
B1	LEC-MR-RB-032
B2	LEC-MR-RB-032

Half load

Driver type	Regeneration option model
A1	LEC-MR-RB-032
A2	Not required.
B1	LEC-MR-RB-032
B2	Not required.

Dimensions/LTF8□NH

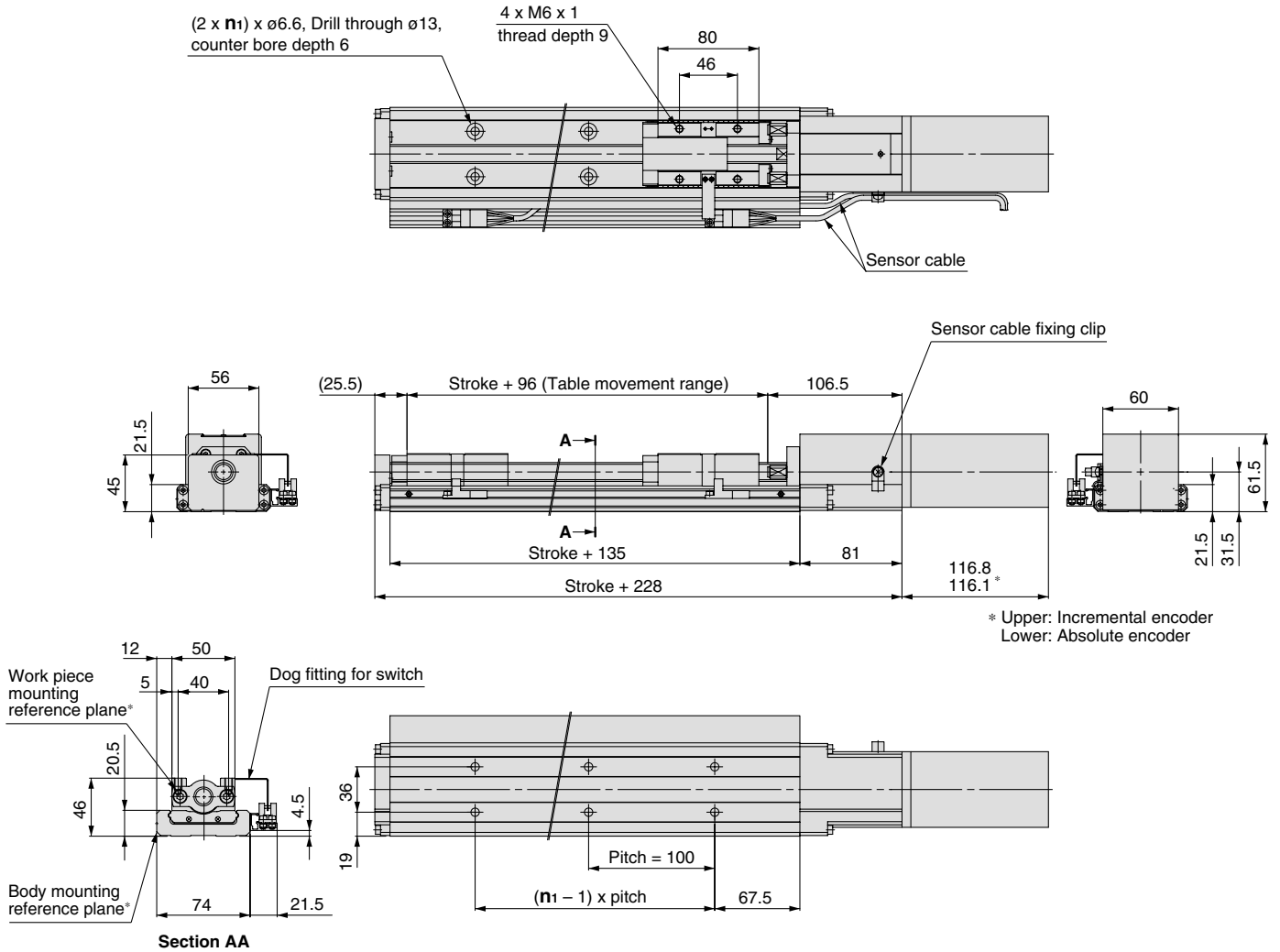

Model	Stroke	n ₁
LTF8□NH- 100K-□	100	2
LTF8□NH- 200K-□	200	3
LTF8□NH- 300K-□	300	4
LTF8□NH- 400K-□	400	5
LTF8□NH- 500K-□	500	6
LTF8□NH- 600K-□	600	7
LTF8□NH- 700K-□	700	8
LTF8□NH- 800K-□	800	9
LTF8□NH- 900K-□	900	10
LTF8□NH-1000K-□	1000	11

* The body mounting reference plane and work piece mounting reference plane should be used as standards when mounting onto equipment. Refer to page 93 for mounting.

Positioning Time Guide

		Positioning time (sec.)				
		1	10	100	500	1000
Speed (mm/s)	10	0.6	1.6	10.6	50.6	100.6
	100	0.6	0.7	1.6	5.6	10.6
	250	0.6	0.7	1.0	2.6	4.6
	500	0.6	0.7	0.9	1.7	2.7

* Values will vary slightly depending on the operating conditions.

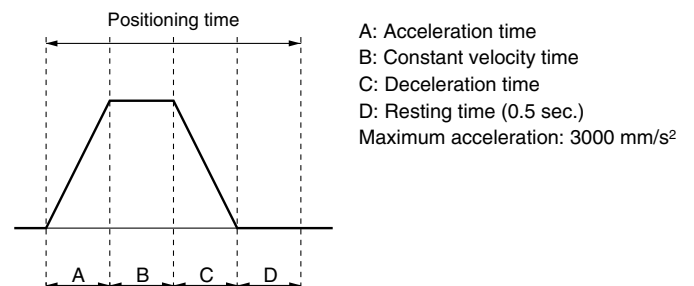

Standard Motor Vertical Mount Series LTF8

Motor Output
200 W

Rolled Ball Screw
∅15 mm/20 mm lead

How to Order

LTF8 S3 NL-300 K-R R 2 A1 - -

Motor type

S3	AC servo motor (Incremental encoder) 200 W
S7	AC servo motor (Absolute encoder) 200 W

Stroke (mm)
Refer to the standard stroke.

Cable type

Nil	Without cable
S	Standard cable
R	Robotic cable (flexible cable)

Cable length

Nil	Without cable
2	2 m
5	5 m
A	10 m

IO connector

Nil	None
H	With IO connector

Photo micro switch

Nil	Without switch/mounting rail
1	NPN 1pc.
2	NPN 2pcs.
3	NPN 3pcs.
4	PNP 1pc.
5	PNP 2pcs.
6	PNP 3pcs.
A	Mounting rail

Driver type

Nil	Without driver
A1	Pulse input type (Incremental encoder) 100 V
A2	Pulse input type (Incremental encoder) 200 V
B1	Pulse input type (Absolute encoder) 100 V
B2	Pulse input type (Absolute encoder) 200 V

Cable entry direction

Nil	Without cable
R	Right
L	Left

Specifications

Standard stroke (mm)		100	200	300	400	500	600	700	800	900	1000
Performance	Body weight (kg)	5.0	5.9	6.7	7.5	8.4	9.2	10.0	10.9	11.7	12.5
	Operating temperature range (°C)	5 to 40 (No condensation)									
	Work load (kg)	5									
	Maximum speed (mm/s)	1000						890	710	580	480
	Positioning repeatability (mm)	±0.05									
Main parts	Motor	AC servo motor (200 W) with lock									
	Encoder	Incremental system/Absolute type									
	Lead screw	Rolled ball screw ∅15 mm, 20 mm lead									
	Guide	Frame-type linear guide									
	Motor/Screw connection	With coupling									
Switch	Model	Photo micro sensor EE-SX674 (Refer to page 95 for details.)									
Driver	Model	LECS□□-□ (Refer to page 97 for details.)									

Note) When using this product, the regeneration option may be required.

Allowable Moment (N·m)

Allowable dynamic moment

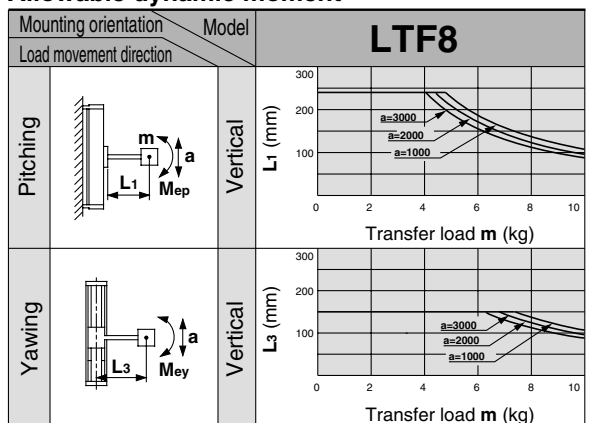

m : Transfer load (kg) Me: Allowable dynamic moment
a : Work piece acceleration (mm/s²) L : Overhang to work piece center of gravity (mm)

Refer to page 94 for deflection data.

Investigation of the regeneration option

Depending on the conditions (speed, addition-subtraction speed, down time, load, etc.), the regeneration option may be required.

The results of consideration in each case of maximum load or half load for the product specification are below.

Please consult SMC when considering the necessity of the regeneration option.

Maximum load

Driver type	Regeneration option model
A1	LEC-MR-RB-032
A2	LEC-MR-RB-032
B1	LEC-MR-RB-032
B2	LEC-MR-RB-032

Half load

Driver type	Regeneration option model
A1	Not required.
A2	Not required.
B1	Not required.
B2	Not required.

Dimensions/LTF8□NL

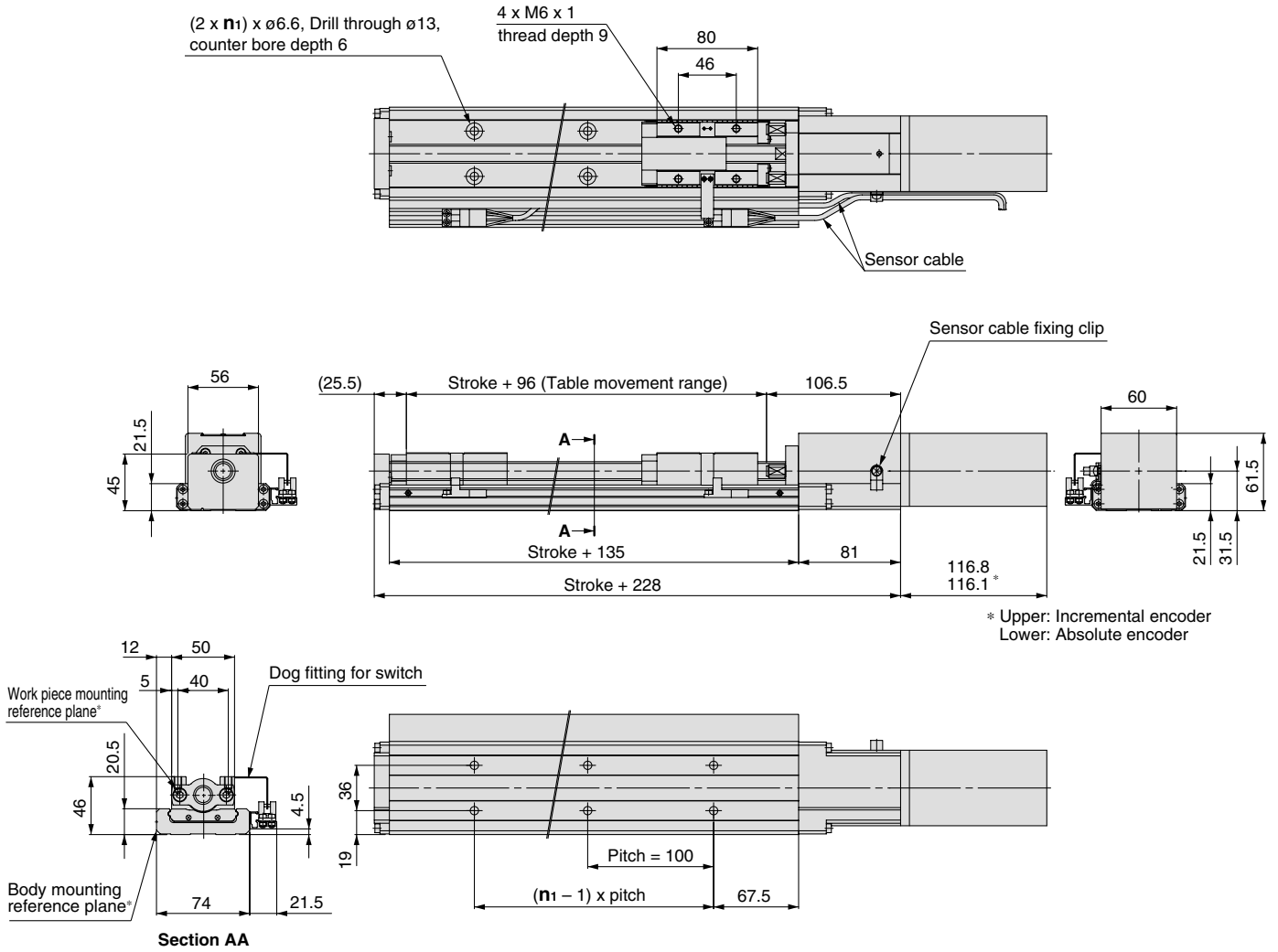

Model	Stroke	n ₁
LTF8□NL- 100K-□	100	2
LTF8□NL- 200K-□	200	3
LTF8□NL- 300K-□	300	4
LTF8□NL- 400K-□	400	5
LTF8□NL- 500K-□	500	6
LTF8□NL- 600K-□	600	7
LTF8□NL- 700K-□	700	8
LTF8□NL- 800K-□	800	9
LTF8□NL- 900K-□	900	10
LTF8□NL-1000K-□	1000	11

* The body mounting reference plane and work piece mounting reference plane should be used as standards when mounting onto equipment. Refer to page 93 for mounting.

Positioning Time Guide

		Positioning time (sec.)				
		1	10	100	500	1000
Speed (mm/s)	10	0.6	1.6	10.6	50.6	100.6
	100	0.6	0.7	1.6	5.6	10.6
	500	0.6	0.7	0.9	1.7	2.7
	1000	0.6	0.7	0.9	1.4	1.9

* Values will vary slightly depending on the operating conditions.

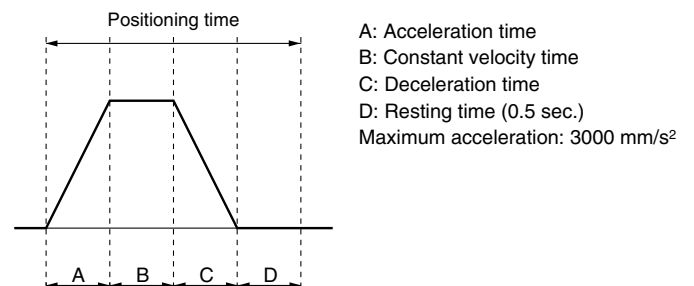

Series LTF Construction

Construction

LTF6/LTF8

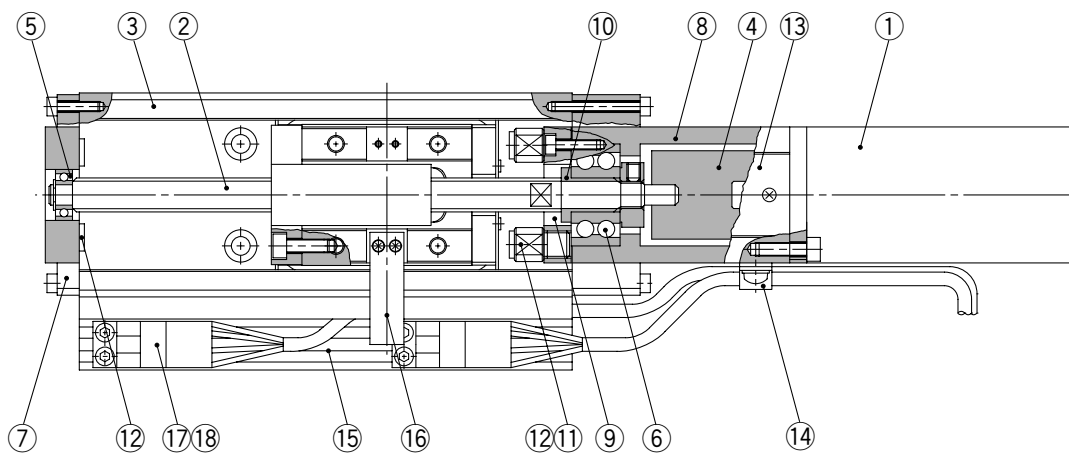

Parts list

No.	Description	Material	Note
1	AC servo motor	—	100/200 W
2	Lead screw	—	Ball screw
3	Frame-type linear guide	—	
4	Coupling	—	
5	Bearing R	—	
6	Bearing F	—	
7	Housing A	Aluminum alloy	
8	Housing B	Aluminum alloy	
9	Bearing retainer	Carbon steel	

No.	Description	Material	Note
10	Spacer	Stainless steel	
11	Bumper bolt	Alloy steel	
12	Bumper	Resin	
13	Housing plate	Mild steel	
14	Cable clip	Resin	
15	Photo micro sensor rail	Aluminum alloy	
16	Dog fitting for switch	Mild steel	Chromate
17	Photo micro sensor		
18	Connector cable for sensor		

Series LTF Mounting

Top Mount

LTF6

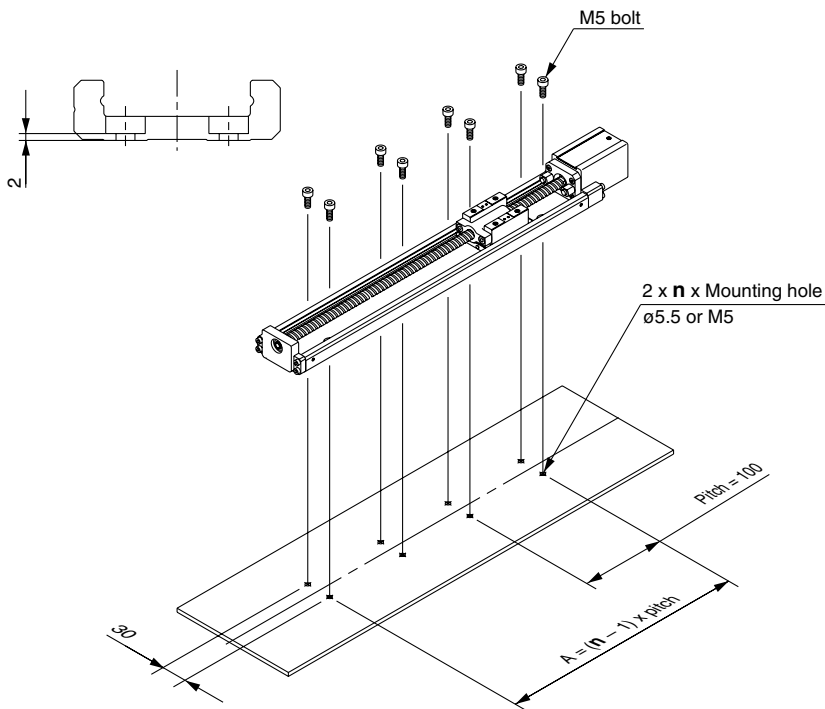

Mounting hole quantity

Stroke	n	Quantity
100	2	4
200	3	6
300	4	8
400	5	10
500	6	12
600	7	14

LTF8

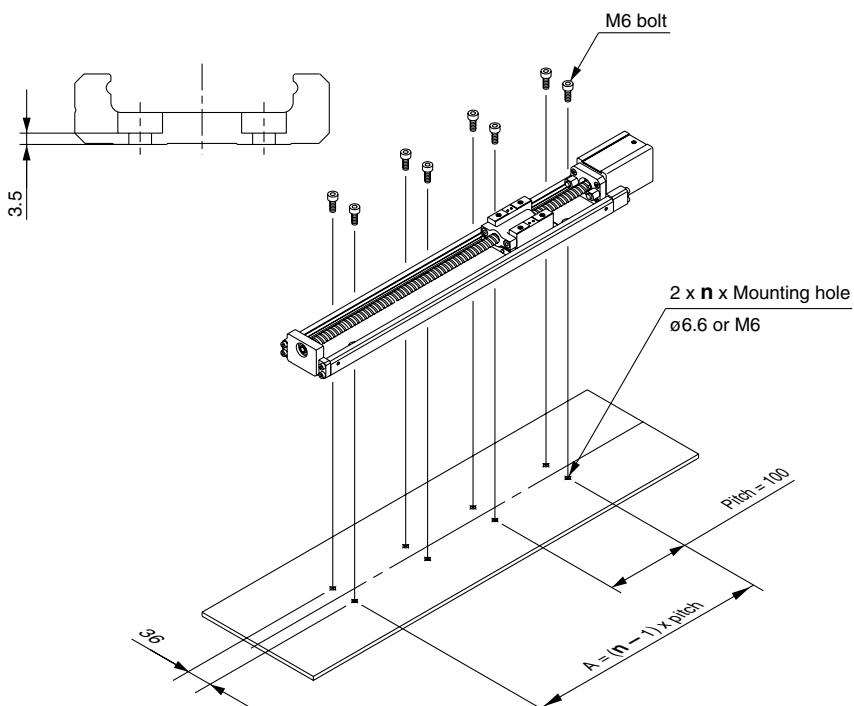

Mounting hole quantity

Stroke	n	Quantity	Stroke	n	Quantity
100	2	4	600	7	14
200	3	6	700	8	16
300	4	8	800	9	18
400	5	10	900	10	20
500	6	12	1000	11	22

Series LTF

Deflection Data

Deflection Data

* Calculated values based on the body's sectional secondary moment.

The load and the amount of deflection at load point W are shown in the graphs below for each series.

LTF6

Horizontal

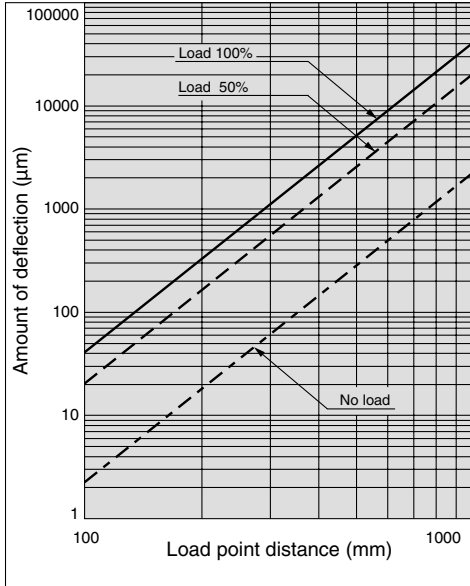

Lateral

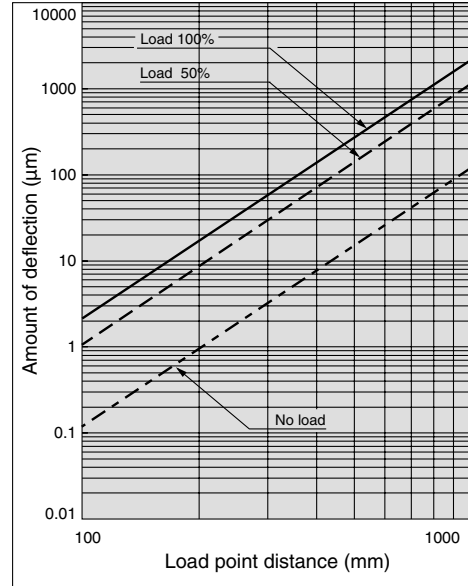

LTF8

Horizontal

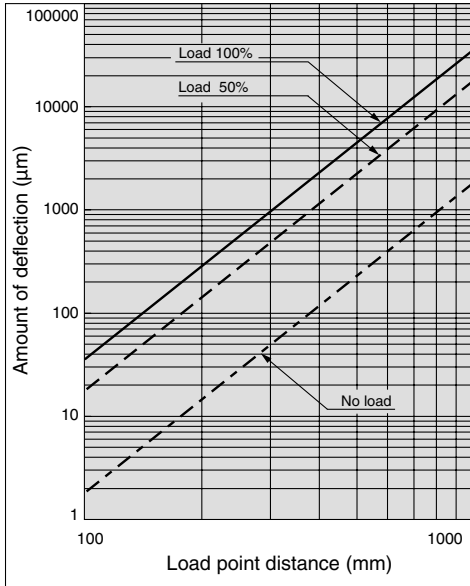

Lateral

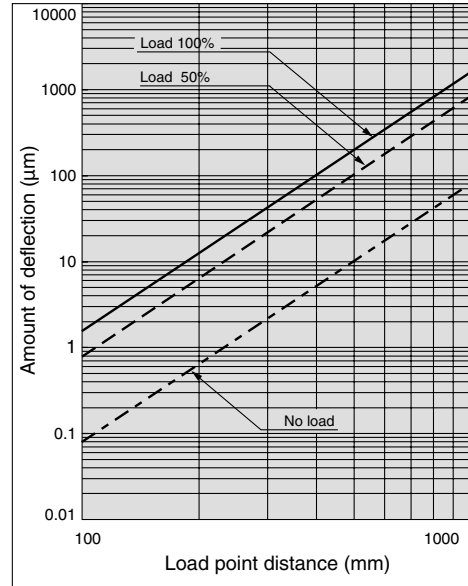

With single end support and table moved to the end of the stroke

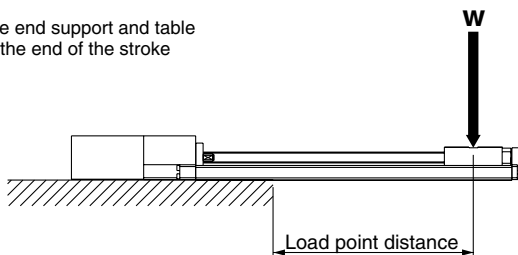

Figure 1. Horizontal

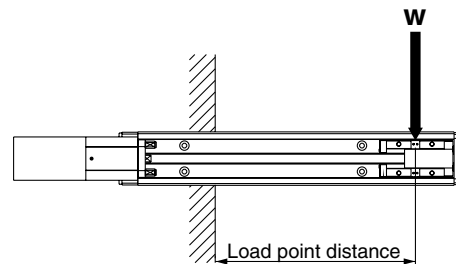

Figure 2. Lateral

Series LTF/Switches

Photo Micro Sensor

Standard Photo Micro Sensor for Home Position (OMRON Corporation)

Rating

Power supply voltage	5 to 24 VDC $\pm 10\%$, Ripple (p-p) 10% or less	
Current consumption	35 mA or less	
Control output	5 to 24 VDC load current (Ic) 100 mA, Residual voltage 0.8 V or less Load current (Ic) 40 mA, Residual voltage 0.4 V or less	
Ambient temperature	Operation: -25 to 55°C (When stored: -30 to 80°C)	
Ambient humidity	Operation: 5 to 85%RH (When stored: 5 to 95%RH)	
Part no.	EE-SX674	EE-SX674P
Output type	NPN	PNP
Part no. of connector with code	EE-1010	

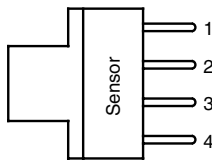

Terminal arrangement

1	Brown	Vcc	⊕
2	White	L*	
3	Black	OUTPUT	
4	Blue	GND (OV)	⊖

* Normally ON when light is blocked. However, if the ⊖ terminal and ⊕ terminal are shorted, it changes to ON when light enters.

Output level circuit

Operating condition of output transistor	ON when light enters	ON when light is blocked
Output circuit	<p>NPN</p> <p>* Normally ON when light is blocked. However, if the ⊖ terminal and ⊕ terminal are shorted, it changes to ON when light enters.</p>	
	<p>PNP</p>	
Time chart	<p>("L" and "+" shorted)</p>	<p>("L" and "+" open)</p>

Photo Micro Sensor/Dog Fitting for Photo Micro Sensor Mounting

Phillips countersunk machine screw (Class 1)(M2.6 x 5)
Tightening torque: 0.16 ± 0.01 N-m

Phillips countersunk machine screw (Class 1)(M2 x 4)
Tightening torque: 0.07 ± 0.01 N-m

Dog fitting for photo micro sensor

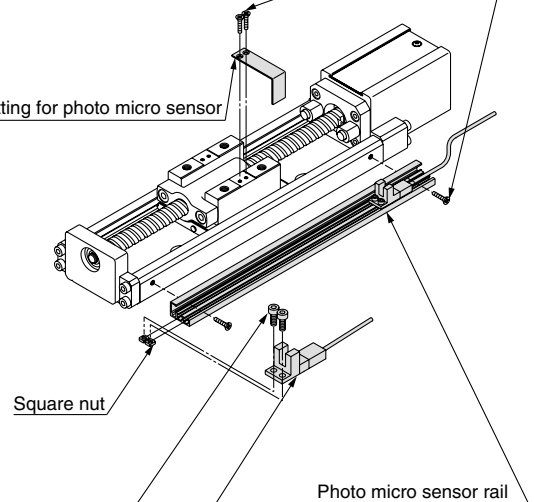

Square nut

Photo micro sensor rail

Photo micro sensor
Connector cable for sensor

Hexagon socket head bolt (M3 x 6)
Tightening torque: 0.29 ± 0.01 N-m

Be sure to use the attached mounting screws. Mount the photo micro sensor as illustrated to the right.
Mount the dog fitting for photo micro sensor as illustrated to the right.
Be sure to observe the prescribed tightening torque. Use special adhesive for screws for locking.



Proximity Switches and Photo Micro Sensors Precautions

Be sure to read before handling.

Refer to the main pages for precautions on respective series.

Photo Micro Sensors and Proximity Switches for Home Position

Incorrect Usage

⚠ Caution

- 1. Do not operate beyond the rated voltage range.**
If applying voltage over the rated voltage range, equipment may be damaged.
- 2. Avoid incorrect wiring such as polarity of power supply.**
Otherwise, equipment may be damaged.
- 3. Do not short circuit the load. (Do not connect to power supply.)**
Otherwise, equipment may be damaged.

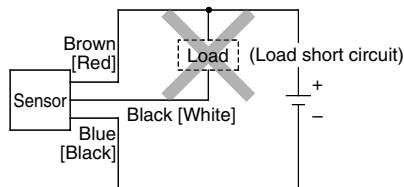

Other

⚠ Caution

- 1. Power lines and high voltage lines should not be in the same piping or duct with wiring of the photo micro sensor, as the system may malfunction or be damaged due to induction. Separate wiring or individual piping is required to avoid such trouble.**
- 2. If operating with a small induction load such as a relay, wire as shown in the figure below. (In this case, be sure to connect a reverse voltage suppression diode.)**

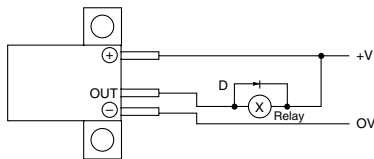



Series LECSA

Series LECSB

AC Servo Motor Driver (Pulse Input Type)

Incremental Type

Series **LECSA**

Absolute Type

Series **LECSB**

Compatible Actuator	Page
Single Axis Electric Actuator Series LJ1H	Page 1
Low Profile Single Axis Electric Actuator Series LG1H	Page 47
Electric Actuator with Integrated Guide Series LTF	Page 59

- Incremental Type/LECSA ————— Page 98
- Absolute Type/LECSB ————— Page 98
- Option ————— Page 104

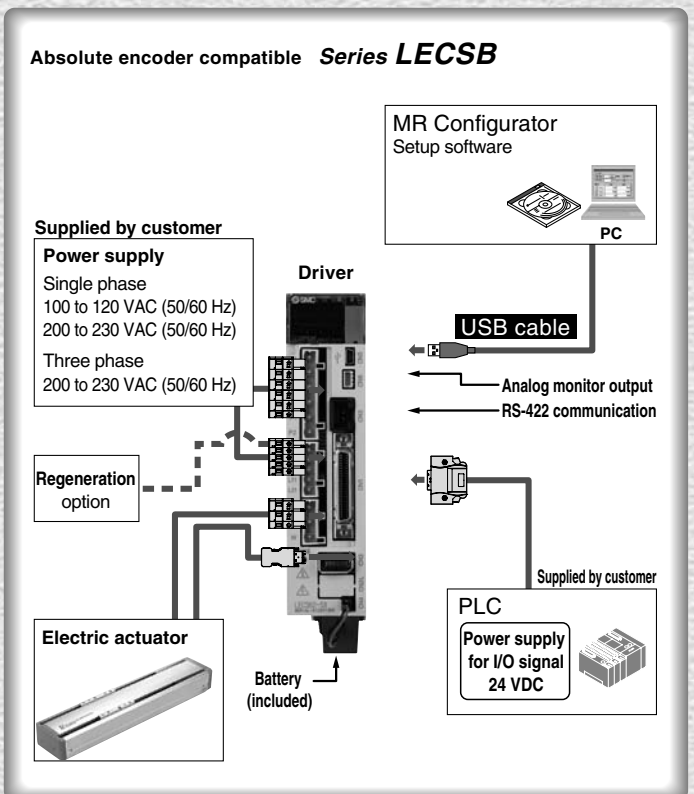
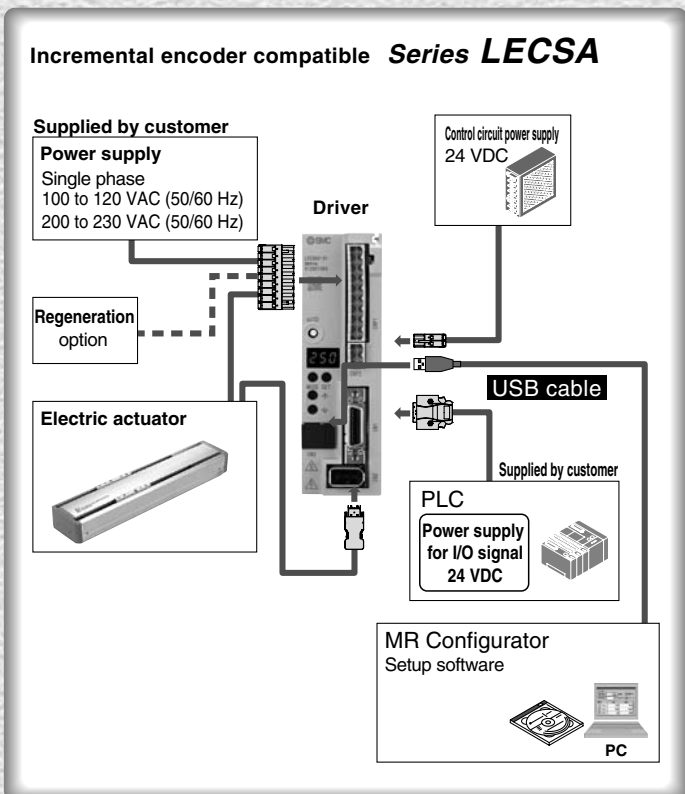

AC Servo Motor Driver (Pulse Input Type)

Incremental Type

Series **LECSA**

Absolute Type

Series **LECSB**



LECSA

LECSB

How to Order

LECS A 1 - S1

Driver type

A	Pulse input type (For incremental encoder)
B	Pulse input type (For absolute encoder)

Motor type

Symbol	Type	Capacity	Encoder
S1	AC servo motor (S2)	100 W	Incremental
S3	AC servo motor (S3)	200 W	
S5	AC servo motor (S6)	100 W	Absolute
S7	AC servo motor (S7)	200 W	

Power supply voltage

1	100 to 120 VAC, 50/60 Hz
2	200 to 230 VAC, 50/60 Hz

Part no. list Select controller type and compatible motor from the combinations in the table below.

Controller part no.	Controller type	Motor type	Power supply voltage
LECSA1-S1	Pulse input type (For incremental encoder)	AC servo motor (S2)	100 to 120 VAC 50/60 Hz
LECSA1-S3		AC servo motor (S3)	
LECSA2-S1		AC servo motor (S2)	200 to 230 VAC 50/60 Hz
LECSA2-S3	AC servo motor (S3)		
LECSB1-S5	Pulse input type (For absolute encoder)	AC servo motor (S6)	100 to 120 VAC
LECSB1-S7		AC servo motor (S7)	50/60 Hz
LECSB2-S5		AC servo motor (S6)	200 to 230 VAC
LECSB2-S7		AC servo motor (S7)	50/60 Hz

Dimensions

LECSA □

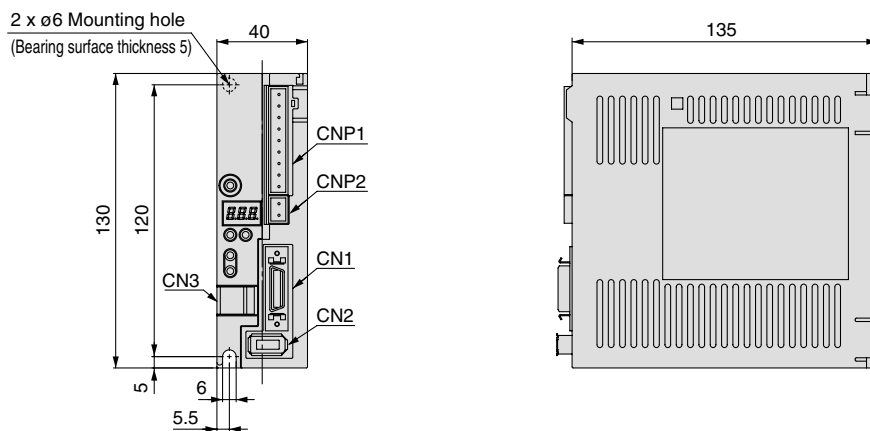

LECSB □

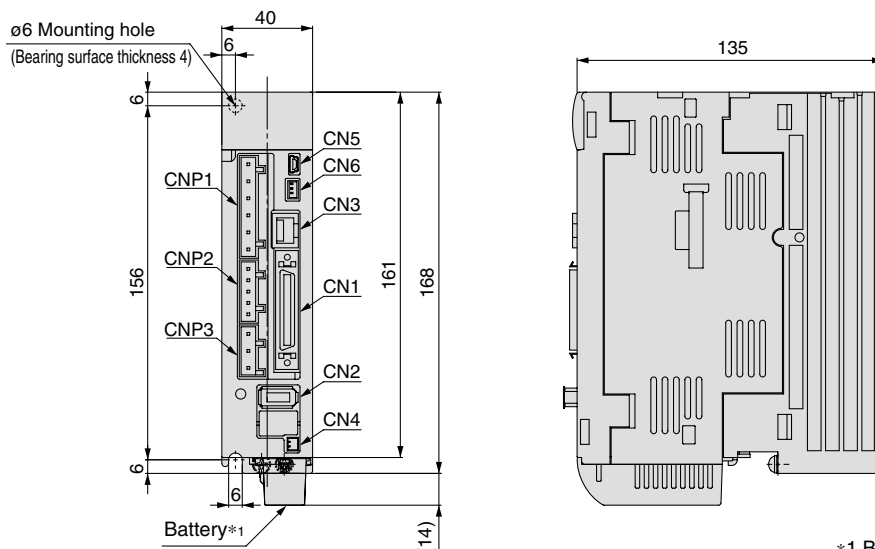

*1 Battery included.

Incremental Type **Series LECSA**
Absolute Type **Series LECSB**

Specifications

Model		LECSA1-S1	LECSA1-S3	LECSA2-S1	LECSA2-S3
Compatible motor capacity [W]		100	200	100	200
Compatible encoder		Incremental 17-bit encoder (Resolution: 131072 p/rev)			
Main power supply	Power voltage [V]	Single phase 100 to 120 VAC (50/60 Hz)		Single phase 200 to 230 VAC (50/60 Hz)	
	Allowable voltage range [V]	Single phase 85 to 132 VAC		Single phase 170 to 253 VAC	
	Rated voltage [A]	3.0	5.0	1.5	2.4
Control power supply	Control power supply voltage [V]	24 VDC			
	Allowable voltage range for control power supply [V]	21.6 to 26.4 VDC			
	Rated voltage [A]	0.5			
Parallel input		6 inputs			
Parallel output		4 outputs			
Max. input pulse frequency [pps]		1 M (when differential receiver), 200 k (when open collector)			
Function	Positioning completion width setting range [pulse]	0 to ±65535 (Pulse command unit)			
	Error excessive	±3 rotations			
	Torque limit	Parameter setting			
	Communication	USB communication			
Operating temperature range [°C]		0 to 40 (No freezing)			
Operating humidity range [%RH]		90 or less (No condensation)			
Storage temperature range [°C]		-20 to 65 (No freezing)			
Storage humidity range [%RH]		90 or less (No condensation)			
Insulation resistance [MΩ]		Between case and SG: 10 (500 VDC)			
Weight [g]		600			

Model		LECSB1-S5	LECSB1-S7	LECSB2-S5	LECSB2-S7
Compatible motor capacity [W]		100	200	100	200
Compatible encoder		Absolute 18-bit encoder (Resolution: 262144 p/rev)			
Main power supply	Power voltage [V]	Single phase 100 to 120 VAC (50/60 Hz)		Three phase 200 to 230 VAC (50/60 Hz) Single phase 200 to 230 VAC (50/60 Hz)	
	Allowable voltage range [V]	Single phase 85 to 132 VAC		Three phase 170 to 253 VAC Single phase 170 to 253 VAC	
	Rated voltage [A]	3.0	5.0	0.9	1.5
Control power supply	Control power supply voltage [V]	Single phase 100 to 120 VAC (50/60 Hz)		Single phase 200 to 230 VAC (50/60 Hz)	
	Allowable voltage range for control power supply [V]	Single phase 85 to 132 VAC		Single phase 170 to 253 VAC	
	Rated voltage [A]	0.4		0.2	
Parallel input		10 inputs			
Parallel output		6 outputs			
Max. input pulse frequency [pps]		1 M (when differential receiver), 200 k (when open collector)			
Function	Positioning completion width setting range [pulse]	0 to ±10000 (Pulse command unit)			
	Error excessive	±3 rotations			
	Torque limit	Parameter setup or external analog input setup (0 to 10 VDC)			
	Communication	USB communication, RS422 communication*1			
Operating temperature range [°C]		0 to 40 (No freezing)			
Operating humidity range [%RH]		90 or less (No condensation)			
Storage temperature range [°C]		-20 to 65 (No freezing)			
Storage humidity range [%RH]		90 or less (No condensation)			
Insulation resistance [MΩ]		Between case and SG: 10 (500 VDC)			
Weight [g]		800			

*1 USB communication and RS422 communication cannot be performed at the same time.

Series LECSA

Series LECSB

Power Supply Wiring Example: LECSA

LECSA□-□

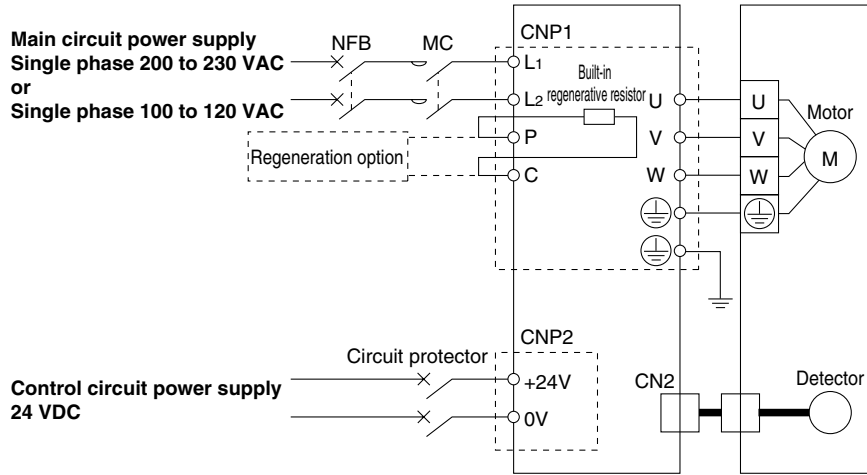

Main Circuit Power Supply Connector: CNP1 *Accessory

Terminal name	Function	Function details
	Protective earth (PE)	Should be grounded via servo motor's earth terminal and control panel's protective earth (PE) after connecting them.
L1	Main circuit power supply	Connect the main circuit power supply. LECSA1: Single phase 100 to 120 VAC, 50/60 Hz LECSA2: Single phase 200 to 230 VAC, 50/60 Hz
L2		
P	Regeneration option	Terminal to connect regeneration option LECSA□-S1: No need for connection LECSA□-S3, S4: Connected at time of shipping. * If regeneration option is required for "Model Selection", connect to this terminal.
C		
U	Servo motor power (U)	Connect to motor cable (U, V, W)
V	Servo motor power (V)	
W	Servo motor power (W)	

Control Circuit Power Supply Connector: CNP2 *Accessory

Terminal name	Function	Function details
24V	Control circuit power supply (24V)	24V side of the control circuit power supply (24 VDC) which supplies the controller.
0V	Control circuit power supply (0V)	0V side of the control circuit power supply (24 VDC) which supplies the controller.

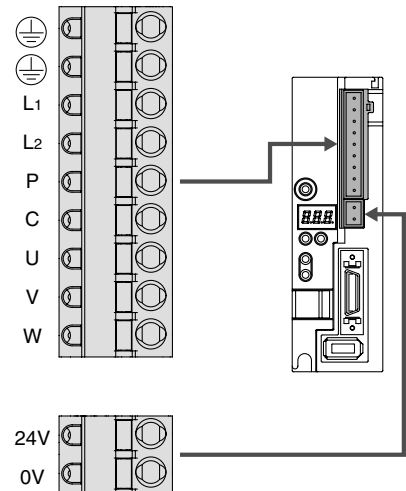

Power Supply Wiring Example: LECSB

LECSB1-□

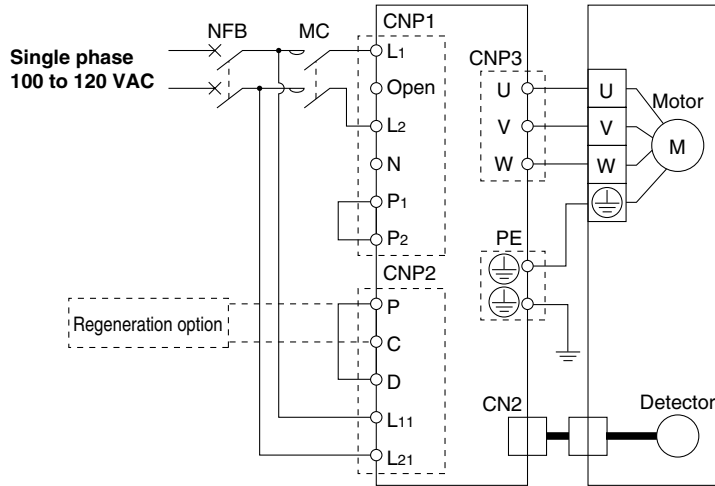

LECSB2-□

For three phase 200 VAC

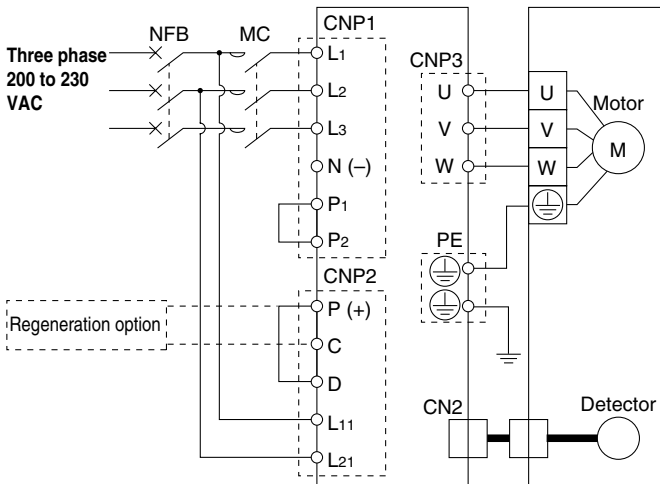

For single phase 200 VAC

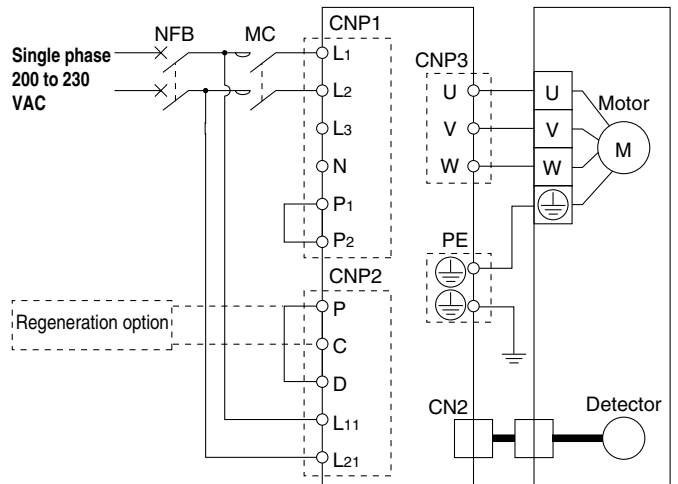

Note) For single phase 200 to 230 VAC, power supply should be connected to L1 and L2 terminals, with nothing connected to L3.

Main Circuit Power Supply Connector: CNP1 *Accessory

Terminal name	Function	Function details
L1	Main circuit power supply	Connect the main circuit power supply. LECSB1: Single phase 100 to 120 VAC, 50/60 Hz Connection terminal: L1,L2 LECSB2: Single phase 200 to 230 VAC, 50/60 Hz Connection terminal: L1,L2 Three phase 200 to 230 VAC, 50/60 Hz Connection terminal: L1,L2,L3
L2		
L3		
N	Regeneration converter	Do not connect.
P1	DC reactor	Connect between P1 and P2. (Connected at time of shipping.)
P2		

Control Circuit Power Supply Connector: CNP2 *Accessory

Terminal name	Function	Function details
P	Regeneration option	Connect between P and D. (Connected at time of shipping.) * If regeneration option is required for "Model Selection", connect to this terminal.
C		
D		
L11	Control circuit power supply (24 V)	24V side of the control circuit power supply (24 VDC) which supplies the controller.
L21	Control circuit power supply (0 V)	0V side of the control circuit power supply (24 VDC) which supplies the controller.

Motor Connector: CNP3 *Accessory

Terminal name	Function	Function details
U	Servo motor power (U)	Connect to motor cable (U, V, W)
V	Servo motor power (V)	
W	Servo motor power (W)	

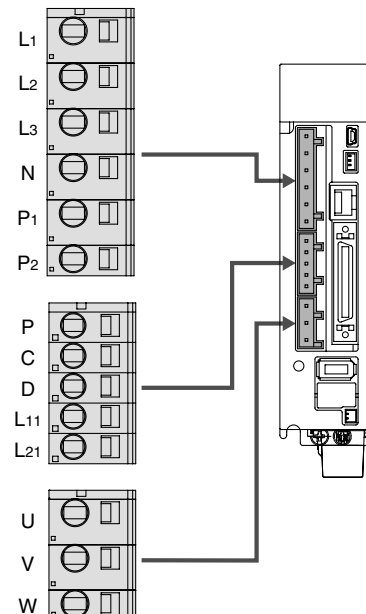

Series LECSA

Series LECSB

Control Signal Wiring Example: LECSA

LECSA□-□

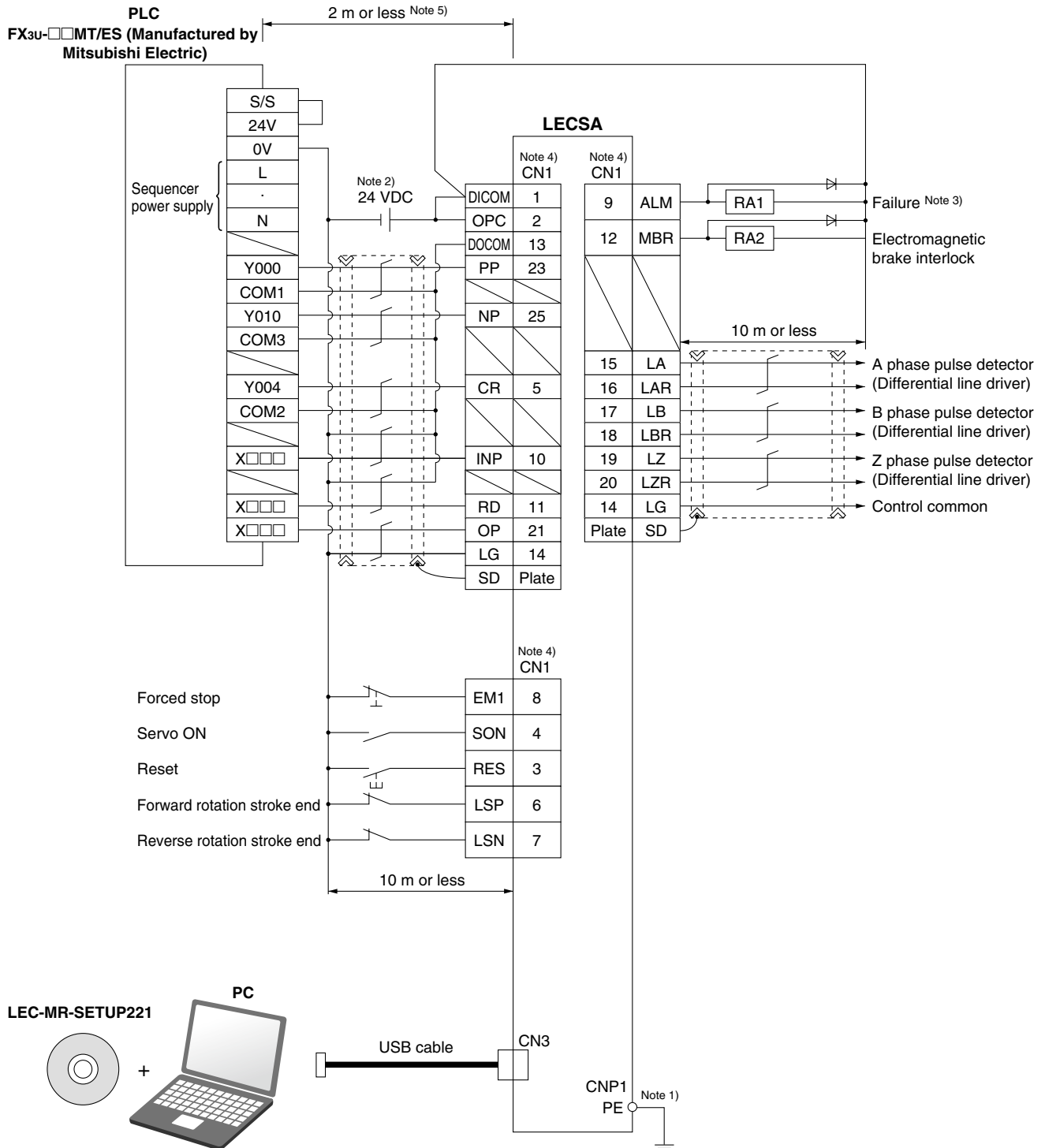

Note 1) For preventing electric shock, be sure to connect the main circuit power supply connector for the servo amplifier (CNP1)'s protective earth (PE) terminal to the control panel's protective earth (PE).

Note 2) For interface use, supply 24 VDC $\pm 10\%$ 200 mA using an external source. 200 mA is the value when all I/O command signals are used and reducing the number of inputs/outputs can decrease current capacity. Refer to "Operation Manual" for required current for interface.

Note 3) The failure (ALM) is ON during normal conditions. When it is OFF (alarm occurs), stop the sequencer signal using the sequence program.

Note 4) The same name signals are connected inside the servo amplifier.

Note 5) For command pulse input with an open collector method. When a positioning unit loaded with a differential line driver method is used, it is 10 m or less.

Control Signal Wiring Example: LECSB

LECSB□-□

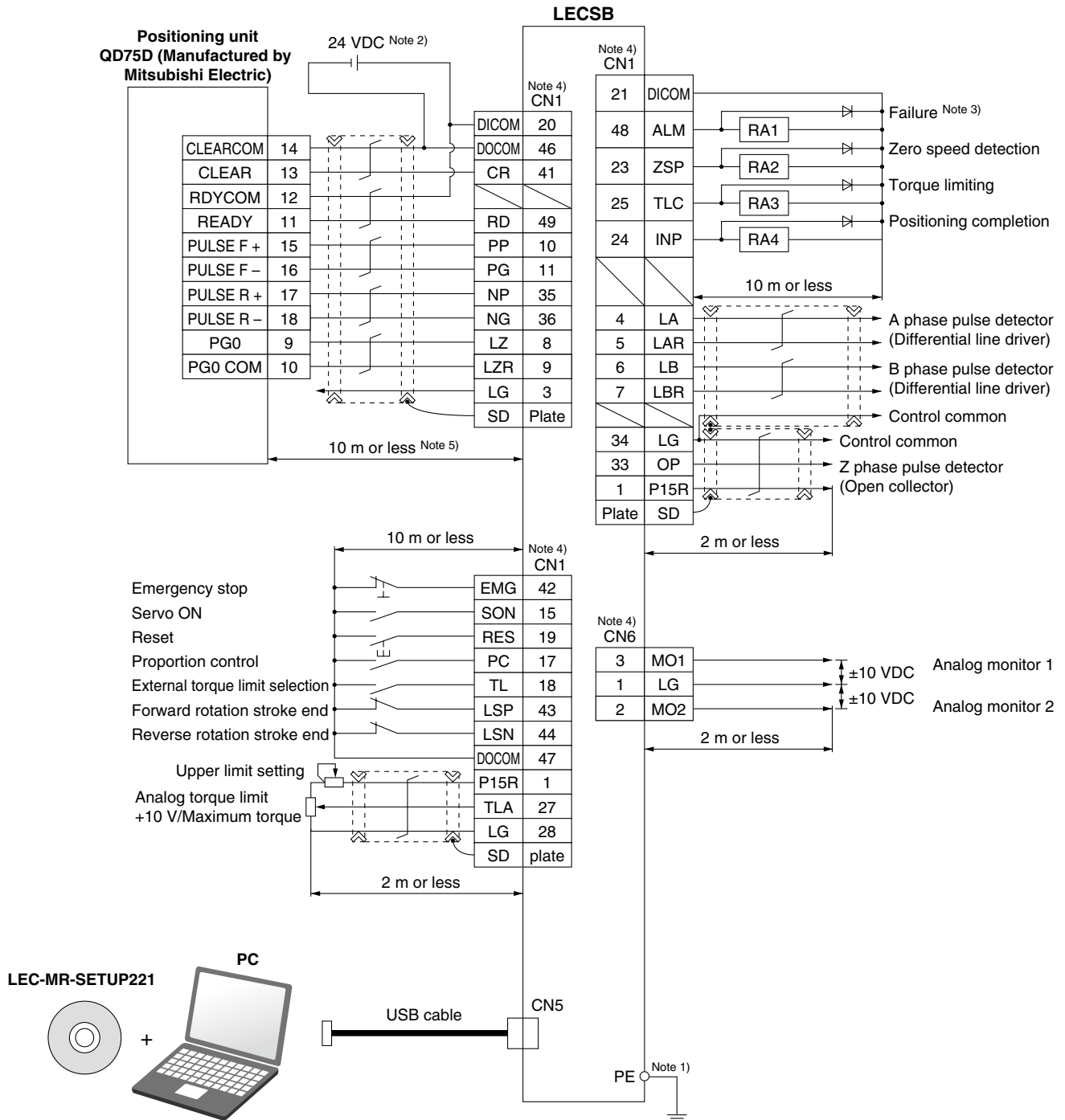

Note 1) For preventing electric shock, be sure to connect the servo amplifier's protective earth (PE) terminal to the control panel's protective earth (PE).
 Note 2) For interface use, supply 24 VDC $\pm 10\%$ 300 mA using an external source.
 Note 3) The failure (ALM) is ON during normal conditions. When it is OFF (alarm occurs), stop the sequencer signal using the sequence program.
 Note 4) The same name signals are connected inside the servo amplifier.
 Note 5) For command pulse input with a differential line driver method. For open collector method, it is 2 m or less.

Series LECSA

Series LECSB

Options

Motor cable, Lock cable, Encoder cable

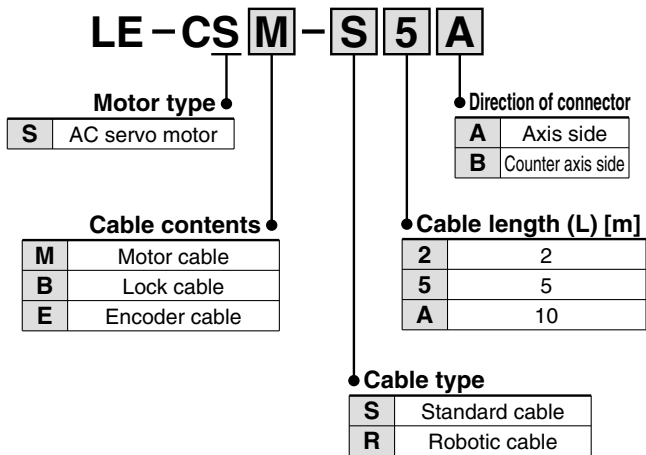

* For cases where the cable is mounted before delivery, the direction of the connector is listed below.
 Motor cable: Counter axis side
 Lock cable: Counter axis side
 Encoder cable: Axis side

LE-CSM-□□: Motor cable

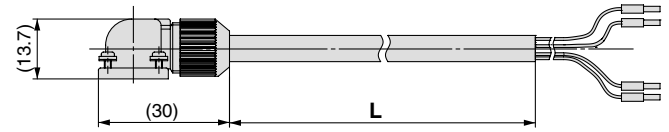

LE-CSB-□□: Lock cable

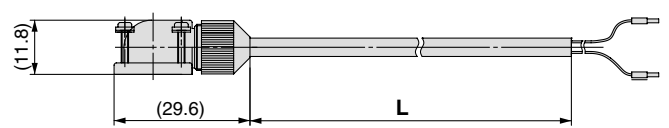

LE-CSE-□□: Encoder cable

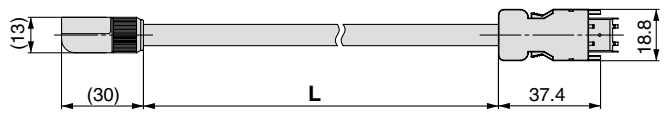

I/O connector

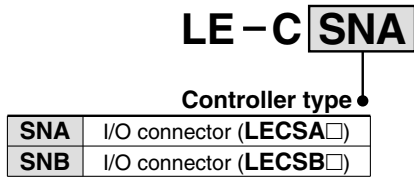

LE-CSNA

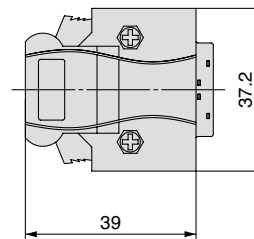

LE-CSNB

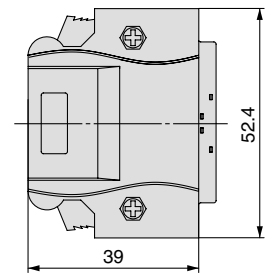

Regeneration option

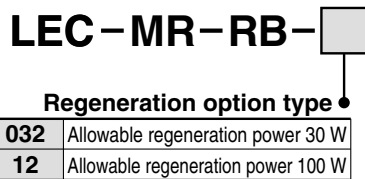

Dimensions [mm]

Model	LA	LB	LC	LD
LEC-MR-RB-032	30	119	99	1.6
LEC-MR-RB-12	40	169	149	2

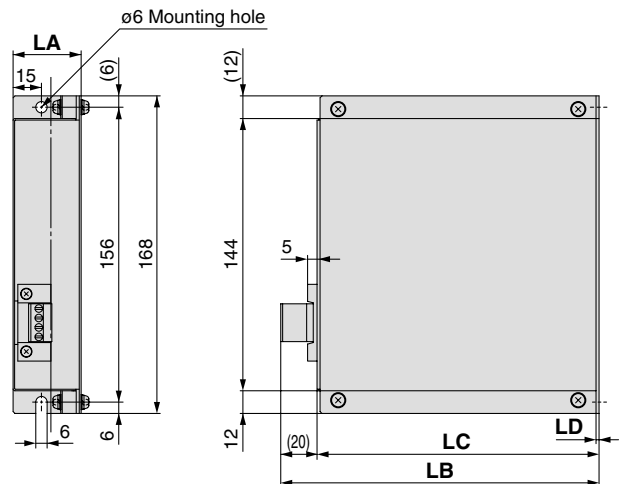

Options

MR Configurator (setup software Japanese version)

LEC – MR – SETUP221

* MRZJW3-SETUP221 manufactured by Mitsubishi Electric.
 Refer to Mitsubishi Electric's website for operating environment and update information.

Compatible PC

When using MR Configurator (setup software), use an IBM PC/AT compatible PC that meets the following operating conditions.

Hardware Requirements

Equipment		MR Configurator (setup software) LEC-MR-SETUP221
Note 1) Note 2) Note 3) PC	OS	Windows®98, Windows®Me, Windows®2000 Professional, Windows®XP Professional/Home Edition, Windows Vista® Home Basic/Home Premium, Business/Ultimate/Enterprise Windows®7 Starter/Home Premium/Professional/Ultimate/Enterprise IBM PC/AT compatible PC (Japanese version)
	Available HD space	130 MB or more
	Communication interface	Use USB port
Display		Resolution 1024 x 768 or more Must be capable of high color (16 bits) display. The connectable with the above PC
Keyboard		The connectable with the above PC
Mouse		The connectable with the above PC
Printer		The connectable with the above PC
Communication cable		LEC-MR-J3USB

Note 1) Windows, Windows Vista, Windows 7 are registered trademarks of Microsoft Corporation in the United States and/or other countries.

Note 2) This software may not run correctly depending on the PC that you are using.

Note 3) Not compatible with 64-bit Windows® XP and 64-bit Windows Vista®.

USB cable (3 m) for setup software

LEC – MR – J3USB

Battery

LEC – MR – J3BAT



Series **LECSA/LECSB** Specific Product Precautions 1

Be sure to read before handling. Refer to back cover for Safety Instructions and the Operation Manual for Electric Actuator Precautions.
Please download it via our website. <http://www.smcworld.com>

Design/Selection

Warning

- 1. Be sure to apply the specified voltage.**
Otherwise, malfunction and breakage may be caused. If the applied voltage is lower than the specified, it is possible that the load cannot be moved due to an internal voltage drop of the driver. Please check the operating voltage before use.
- 2. Do not operate the product beyond the specifications.**
Otherwise, a fire, malfunction or actuator damage can result. Please check the specifications before use.
- 3. Install an emergency stop circuit outside of the enclosure.**
Please install an emergency stop outside of the enclosure so that it can stop the system operation immediately and intercept the power supply.
- 4. In order to prevent damage due to the breakdown and the malfunction of the driver and its peripheral devices, a backup system should be established previously by giving a multiple-layered structure or a fail-safe design to the equipment, etc.**
- 5. If a danger against the personnel is expected due to an abnormal heat generation, smoking, ignition, etc., of the driver and its peripheral devices, cut off the power supply for the product and the system immediately.**

Handling

Warning

- 1. Do not touch the inside of the driver and its peripheral devices.**
It may cause an electric shock or damage to the driver.
- 2. Do not perform the operation or setting of the product with wet hands.**
It may cause an electric shock.
- 3. Product with damage or the one lacking of any components should not be used.**
It may cause an electric shock, fire, or injury.
- 4. Use only the specified combination between the electric actuator and driver.**
It may cause damage to the actuator or the driver.
- 5. Be careful not to be caught or hit by the workpiece while the actuator is moving.**
It may cause an injury.
- 6. Do not connect the power supply or power on the product before confirming the area to which the workpiece moves is safe.**
The movement of the workpiece may cause an accident.
- 7. Do not touch the product when it is energized and for some time after power has been disconnected, as it is very hot.**
It may lead to a burn due to the high temperature.
- 8. Check the voltage using a tester for more than 5 minutes after power-off in case of installation, wiring and maintenance.**
It may cause an electric shock, fire, or injury.

Handling

Warning

- 9. Static electricity may cause malfunction or break the driver. Do not touch the driver while power is supplied.**
When touching the driver for maintenance, take sufficient measures to eliminate static electricity.
- 10. Do not use the product in an area where dust, powder dust, water, chemicals or oil is in the air.**
It will cause failure or malfunction.
- 11. Do not use the product in an area where a magnetic field is generated.**
It will cause failure or malfunction.
- 12. Do not install the product in the environment of flammable gas, explosive gas and corrosive gas.**
It could lead to fire, explosion and corrosion.
- 13. Radiant heat from strong heat supplies such as a furnace, direct sunlight, etc., should not be applied to the product.**
It will cause failure of the driver or its peripheral devices.
- 14. Do not use the product in an environment subject to a temperature cycle.**
It will cause failure of the driver or its peripheral devices.
- 15. Do not use the product in a place where surges are generated.**
When there are units that generate a large amount of surge around the product (e.g., solenoid type lifters, high frequency induction furnaces, motors, etc.), this may cause deterioration or damage to the product's internal circuit. Avoid supplies of surge generation and crossed lines.
- 16. Do not install the product in an environment under the effect of vibrations and impacts.**
It will cause failure or malfunction.
- 17. When a surge generating load such as a relay or solenoid valve is directly driven, use a product that incorporates a surge absorption element.**

Installation

Warning

- 1. Install the driver and its peripheral devices on a fire-proof material.**
A direct installation on or near a flammable material may cause fire.
- 2. Do not install the product in a place subject to vibrations and impacts.**
It will cause failure or malfunction.
- 3. The driver should be affixed vertically to a vertical wall. Do not cover the driver's exhaust opening.**
- 4. Install the driver and its peripheral devices on a flat surface.**
If the mounting surface is distorted or not flat, an unacceptable force may be added to the housing, etc., to cause troubles.



Series *LECSA/LECSB*

Specific Product Precautions 2

Be sure to read before handling. Refer to back cover for Safety Instructions and the Operation Manual for Electric Actuator Precautions.
Please download it via our website. <http://www.smcworld.com>

Power Supply

⚠ Caution

1. Use a power supply that has low noise between lines and between power and ground.
In cases where noise is high, an isolation transformer should be used.
2. To prevent surges from lightning, an appropriate measure should be taken. Ground the surge absorber for lightning separately from the grounding of the driver and its peripheral devices.

Wiring

⚠ Warning

1. The driver will be damaged if a commercial power supply (100V/200V) is added to the driver's servo motor power (U, V, W). Be sure to check wiring such as wiring mistakes when the power supply is turned on.
2. Connect the ends of the U, V, W wires from the motor cable correctly to the phases (U, V, W) of the servo motor power.
If these wires do not match up, it is unable to control the servo motor.

Grounding

⚠ Warning

1. Be sure to carry out grounding in order to ensure the noise tolerance.
For grounding actuator, connect the copper wire of the actuator to the driver's protective earth (PE) terminal and connect the copper wire of the driver to the earth via the control panel's protective earth (PE) terminal. Do not connect them directly to the control panel's protective earth (PE) terminal.

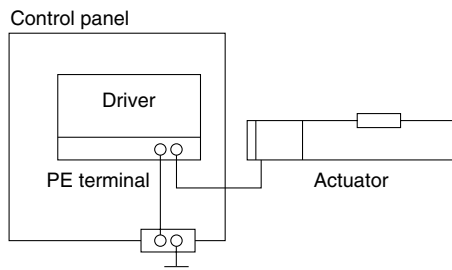

2. In the unlikely event that malfunction is caused by ground, please disconnect the unit from ground.

Maintenance

⚠ Warning

1. Perform a maintenance check periodically.
Confirm wiring and screws are not loose.
Loose screws or wires may cause unintentional malfunction.
2. Conduct an appropriate functional inspection after completing the maintenance.
At times where the equipment or machinery does not operate properly, conduct an emergency stop of the system. Otherwise, an unexpected malfunction may occur and it will become impossible to secure the safety. Conduct a test of the emergency stop in order to confirm the safety of the equipment.
3. Do not disassemble, modify or repair the driver and its peripheral devices.
4. Do not put anything conductive or flammable inside of the driver.
It may cause a fire.
5. Do not conduct an insulation resistance test and withstand voltage test on this product.
6. Ensure sufficient space for maintenance activities.
Design the system that allows required space for maintenance.