

# Compact Cylinder Series *NCQ8*

Bore size: 056(9/16"), 075(3/4"), 106(1 1/16"), 150(1 1/2")  
200(2"), 250(2 1/2"), 300(3"), 400(4")



**Now available in 300 (3") and 400 (4") bore sizes**

Standard type	Actuation	Style		Bore size	Standard stroke (in)	Page		
	Double acting	Single rod	Built-in magnet	056(9/16") 075(3/4") 106(1 1/16") 150(1 1/2") 200(2") 250(2 1/2") 300(3")** 400(4")**	012(1/8"), 025(1/4"), 037(3/8"), 050(1/2"), 062(5/8"), 075(3/4"), 087(7/8"), 100(1"), 125(1 1/4"), 150(1 1/2"), 175(1 3/4"), 200(2"), 250(2 1/2"), 300(3"), 350(3 1/2"), 400(4")	1		
		Double rod	Rod end male thread			13		
	Single acting	Single rod	With rubber bumper			22		
Super Compact	Actuation	Style				Bore size	Standard stroke (in)	Page
	Double acting	Single rod	★			056(9/16") 075(3/4") 106(1 1/16") 150(1 1/2") 200(2") 250(2 1/2") 300(3")** 400(4")**	025(1/4"), 037(3/8"), 050(1/2"), 062(5/8"), 075(3/4"), 087(7/8"), 100(1"), 125(1 1/4"), 150(1 1/2"), 175(1 3/4"), 200(2"), 250(2 1/2"), 300(3"), 350(3 1/2"), 400(4")	1
	Single acting	Single rod	★					22

Note) Built-in magnet type has a minimum stroke of 025 (1/4").

★ Super Compact type is only available with a magnet.

★★ 300 (3") and 400 (4"): Available for double acting type only.

# COMPACT CYLINDER

- Square body allows close center to center mounting
- Visibility of auto switch is improved.
- Auto switch mountable on multiple-sides
- No protrusion from cylinder's exterior when mounting auto switches

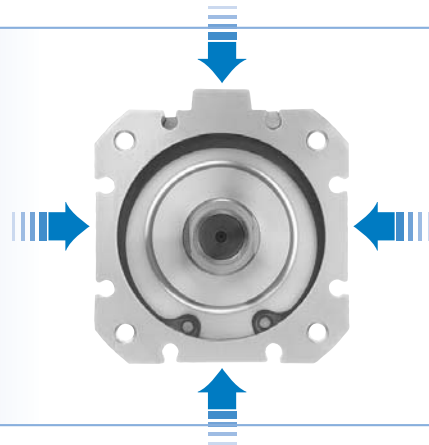

Snap ring design allows for quick and easy maintenance. Just by removing the snap ring and collar, seal replacement is possible.

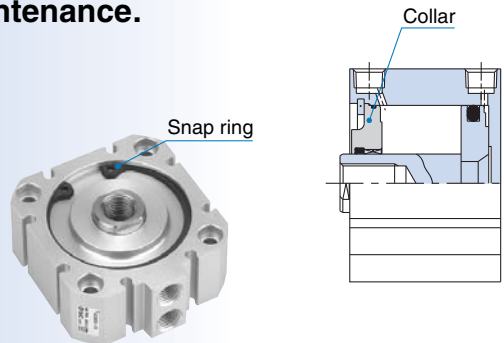

Super Compact type is available - saves additional space.

**NCDQ8□**  
With auto switch,  
Standard type

Difference in dimension (in)

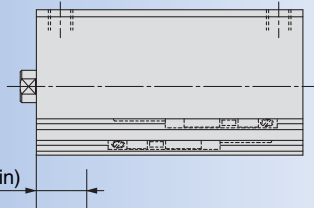

**NCDQ8□Z**  
With auto switch,  
Super Compact type

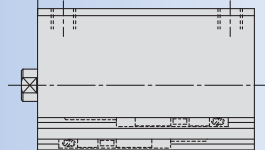

Bore size	Cylinder tube whole length (in)*		Difference in dimension (in)
	NCDQ8□	NCDQ8□Z	
056(9/16")	1.44	1.06	0.38
075(3/4")	1.44	1.06	0.38
106(1 1/16")	1.75	1.25	0.50
150(1 1/2")	1.75	1.25	0.50
200(2")	1.81	1.19	0.62
250(2 1/2")	2.06	1.44	0.62
300(3")	2.13	1.50	0.63
400(4")	2.44	1.80	0.63

\*Indicates the dimension for 0 (zero) stroke of double acting, single rod.

Series  
**NCDQ8**

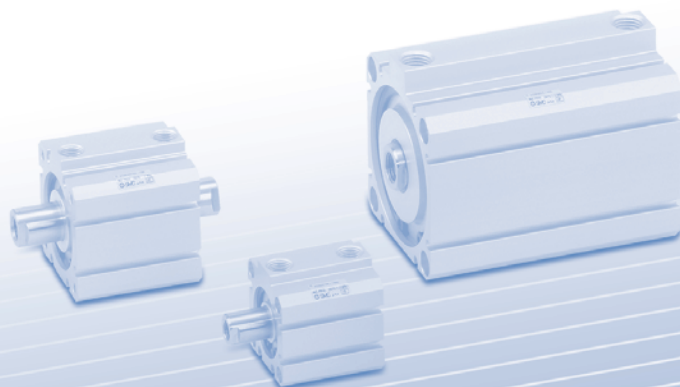

# Compact Cylinder Double Acting, Single Rod Series **NCQ8**

Bore size: 056(9/16"), 075(3/4"), 106(1 1/16"), 150(1 1/2"), 200(2"), 250(2 1/2"), 300(3"), 400(4")

## How to Order

**Without auto switch** NCQ8 **B** **056** - **025** **□** - **□**

**With auto switch** NCDQ8 **B** **Z** **056** - **025** **□** - **M9BW** **S** - **□**

**Built-in magnet**

**Mounting**

<b>B</b>	Through-hole
<b>A</b>	Both ends tapped
<b>C</b>	Rear clevis
<b>E</b>	Screw clearance hole, front mount
<b>M</b>	Screw clearance hole, rear mount
<b>N</b>	Screw clearance hole, through

**Overall length type**

<b>Nil</b>	Standard
<b>Z</b>	Super Compact

**Nominal bore size**

<b>056</b>	9/16"
<b>075</b>	3/4"
<b>106</b>	1 1/16"
<b>150</b>	1 1/2"
<b>200</b>	2"
<b>250</b>	2 1/2"
<b>300</b>	3"
<b>400</b>	4"

**Cylinder stroke (in)**

Symbol	Stroke (in)	Symbol	Stroke (in)	Symbol	Stroke (in)	Symbol	Stroke (in)
<b>012</b>	1/8"	<b>062</b>	5/8"	<b>125</b>	1 1/4"	<b>250</b>	2 1/2"
<b>025</b>	1/4"	<b>075</b>	3/4"	<b>150</b>	1 1/2"	<b>300</b>	3"
<b>037</b>	3/8"	<b>087</b>	7/8"	<b>175</b>	1 3/4"	<b>350</b>	3 1/2"
<b>050</b>	1/2"	<b>100</b>	1"	<b>200</b>	2"	<b>400</b>	4"

**X-Option**

<b>Nil</b>	Standard
<b>XB6</b>	High temp.
<b>XC4</b>	With scraper

Note 3) XB6: Not available with magnet.  
\*Refer to page 36.

**Number of auto switches**

<b>Nil</b>	2 pcs.
<b>S</b>	1 pc.
<b>n</b>	"n" pcs.

**Auto switch type**

<b>Nil</b>	Without auto switch (Built-in magnet cylinder)
------------	--

\*Refer to the table below for auto switch model numbers.  
\*Auto switches are shipped together, (but not assembled).

**Body option**

<b>Nil</b>	Standard (Female rod end)
<b>C</b>	Rubber bumper
<b>M</b>	Male rod end

Note 2) Stroke will be reduced by 0.06" for rubber bumper type.  
\*Combination of body options(CM) is available.

Note 1) With auto switch is available on strokes 025(1/4") and greater.

## Applicable Auto Switches

Type	Special function	Electrical entry	Indicator light	Wiring (output)	Load voltage		Auto switch model	Lead wire length (in)*				Applicable load					
					DC	AC		20(0.5m)	39(1m)	118(3m)	197(5m)						
								(Nil)	(M)	(L)	(Z)						
Solid state switch	—	Grommet	—	3-wire (NPN)	24 V	5 V, 12 V	—	M9NV	M9N	●	—	●	○	IC circuit			
				3-wire (PNP)						●	—	●	○				
				2-wire						●	—	●	○				
	Diagnostic indication (2-color display)	Grommet	Yes	3-wire (NPN)	24 V	5 V, 12 V	—	M9NWV	M9NW	●	●	●	○	IC circuit			
				3-wire (PNP)						●	●	●	○				
				2-wire						●	●	●	○				
Reed switch	—	Grommet	—	3-wire (NPN equiv.)	24 V	5 V	100 V	A96V	A96	●	—	●	—	IC circuit			
				2-wire						5 V, 12 V	A90V	A90	●		—	●	—
										12 V			A93V		A93	●	—

\*Lead wire length symbols: 20in (0.5 m)..... Nil (Example) M9NW \*Solid state switches marked with a "○" symbol are produced upon receipt of order.  
39in (1 m)..... M M9NWM \*39 in (1 m: M): Available in the D-M9□W(V) only.  
118in (3 m)..... L M9NWL  
197in (5 m)..... Z M9NWZ

# Series NCQ8

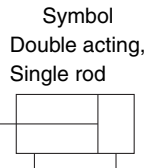

## Specifications

Bore size	056(9/16")	075(3/4")	106(1 1/16")	150(1 1/2")	200(2")	250(2 1/2")	300(3")	400(4")
Piping size	#10-32UNF	#10-32UNF	NPT1/8	NPT1/8	NPT1/8	NPT1/4	NPT1/4	NPT3/8
Type	Pneumatic (Non-lube)							
Action	Double acting, Single rod							
Fluid	Air							
Proof pressure	300PSI (2.1MPa)							
Maximum operating pressure	200PSI (1.4MPa)							
Minimum operating pressure	11PSI (0.07MPa)	8PSI (0.05MPa)						
Ambient and fluid temperature	Without auto switch	15 to 150F(-10 to 65C) (No freezing)						
	With auto switch	15 to 140F(-10 to 60C) (No freezing)						
Cushion	Rubber bumper (C)							
Rod end thread	Female thread							
Rod end thread tolerance	ANSI/ASME B 1.1-1989							
Stroke tolerance	0 to +0.04 in (+1.0mm)							
Mounting	Through-hole (B), Both ends tapped (A), Clevis, SCH (E,M,N)							
Piston speed	2 to 20in/sec (50 to 500mm/s)						2 to 11.8in/sec (50 to 300mm/s)	

## Applicable Stroke

Unit: inch

Bore size	Standard stroke
056(9/16")	012(1/8"), 025(1/4"), 037(3/8"), 050(1/2") 062(5/8"), 075(3/4"), 087(7/8"), 100(1") 125(1 1/4"), 150(1 1/2"), 175(1 3/4"), 200(2") 250(2 1/2"), 300(3"), 350(3 1/2"), 400(4")
075(3/4")	
106(1 1/16")	
150(1 1/2")	
200(2")	
250(2 1/2")	
300(3")	
400(4")	

\* With auto switch is available on strokes 025(1/4") and greater.

## Theoretical Output Table

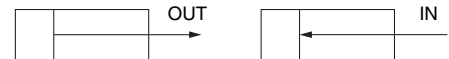

Unit: lbf

Bore size (in)	Operating direction	Operating pressure/PSI (MPa)			
		45(0.3)	75(0.5)	145(1.0)	200(1.4)
056(9/16")	IN	8.87	14.6	28.6	39.2
	OUT	11.1	18.2	35.7	48.9
075(3/4")	IN	16.4	27.0	52.9	72.5
	OUT	19.9	32.7	64.1	87.8
106(1 1/16")	IN	30.8	50.8	99.5	136
	OUT	39.7	65.3	128	175
150(1 1/2")	IN	65.7	108	212	290
	OUT	79.5	131	256	351
200(2")	IN	121	200	391	536
	OUT	141	232	456	624
250(2 1/2")	IN	201	330	648	888
	OUT	221	363	712	975
300(3")	IN	278	463	927	1298
	OUT	304	506	1013	1418
400(4")	IN	506	844	1689	2364
	OUT	540	900	1801	2522

# Compact Cylinder Double Acting, Single Rod *Series NCQ8*

## Weight Table

**Product's Weight (Double Acting, Single Rod, Without Auto Switch)**

(OZ)

Stroke Model	012 (1/8")	025 (1/4")	037 (3/8")	050 (1/2")	062 (5/8")	075 (3/4")	087 (7/8")	100 (1")	125 (1 1/4")	150 (1 1/2")	175 (1 3/4")	200 (2")	250 (2 1/2")	300 (3")	350 (3 1/2")	400 (4")
NCQ8□056-□	0.82	0.96	1.10	1.24	1.38	1.52	1.66	1.80	2.09	2.37	2.65	2.93	3.50	4.06	4.63	5.19
NCQ8□075-□	1.24	1.45	1.66	1.86	2.07	2.28	2.49	2.70	3.11	3.53	3.94	4.36	5.19	6.03	6.86	7.69
NCQ8□106-□	3.27	3.64	4.01	4.38	4.75	5.12	5.49	5.86	6.60	7.34	8.08	8.82	10.3	11.8	13.3	14.8
NCQ8□150-□	5.30	5.84	6.37	6.91	7.45	7.99	8.53	9.07	10.2	11.3	12.4	13.4	15.6	17.8	19.9	22.1
NCQ8□200-□	8.89	9.69	10.5	11.3	12.1	12.9	13.7	14.5	16.1	17.7	19.3	20.8	24.0	27.2	30.4	33.5
NCQ8□250-□	14.3	15.1	15.9	16.7	17.5	18.3	19.1	20.0	21.6	23.2	24.8	26.6	29.6	33.2	36.1	39.3
NCQ8□300-□	20.9	22.1	23.0	24.2	25.4	26.5	27.7	28.9	31.2	33.6	35.9	38.3	42.9	47.6	52.3	57.0
NCQ8□400-□	40.4	42.1	43.4	45	46.7	48.3	49.9	51.6	54.8	58.1	61.3	64.6	71.1	77.6	84.1	90.6

**Product's Weight (Double Acting, Single Rod, With Auto Switch)**

(OZ)

Stroke Model	012 (1/8")	025 (1/4")	037 (3/8")	050 (1/2")	062 (5/8")	075 (3/4")	087 (7/8")	100 (1")	125 (1 1/4")	150 (1 1/2")	175 (1 3/4")	200 (2")	250 (2 1/2")	300 (3")	350 (3 1/2")	400 (4")
NCDQ8□056-□	—	2.14	2.28	2.42	2.56	2.70	2.84	2.99	3.27	3.55	3.83	4.11	4.68	5.24	5.81	6.37
NCDQ8□075-□	—	3.35	3.56	3.77	3.98	4.18	4.39	4.60	5.02	5.43	5.85	6.27	7.10	7.93	8.76	9.59
NCDQ8□106-□	—	6.99	7.36	7.73	8.10	8.47	8.84	9.21	9.95	10.7	11.5	12.2	13.7	15.2	16.7	18.1
NCDQ8□150-□	—	11.4	11.9	12.5	13.0	13.5	14.1	14.6	15.7	16.8	17.9	18.9	21.1	23.3	25.4	27.6
NCDQ8□200-□	—	17.9	18.7	19.5	20.3	21.1	21.9	22.7	24.2	25.8	27.4	29.0	32.2	35.4	38.5	41.7
NCDQ8□250-□	—	25.3	26.1	26.9	27.7	28.5	29.3	30.1	31.8	33.4	35.0	36.6	39.9	43.1	46.4	49.6
NCDQ8□300-□	—	35.0	36.2	37.4	38.5	39.7	40.9	42.1	44.4	46.8	49.1	51.4	56.1	60.8	65.5	70.2
NCDQ8□400-□	—	61.1	62.7	64.4	66.0	67.6	69.3	70.9	74.1	77.4	80.7	83.9	90.4	96.9	103.4	110.0

**Product's Weight (Double Acting, Single Rod, With Auto Switch, Super Compact)**

(OZ)

Stroke Model	012 (1/8")	025 (1/4")	037 (3/8")	050 (1/2")	062 (5/8")	075 (3/4")	087 (7/8")	100 (1")	125 (1 1/4")	150 (1 1/2")	175 (1 3/4")	200 (2")	250 (2 1/2")	300 (3")	350 (3 1/2")	400 (4")
NCDQ8□Z056-□	—	1.61	1.75	1.89	2.03	2.17	2.32	2.46	2.74	3.02	3.30	3.58	4.15	4.71	5.28	5.84
NCDQ8□Z075-□	—	2.52	2.73	2.94	3.15	3.36	3.56	3.77	4.19	4.60	5.02	5.44	6.27	7.10	7.93	8.77
NCDQ8□Z106-□	—	5.05	5.42	5.79	6.16	6.53	6.90	7.27	8.01	8.75	9.49	10.3	11.8	13.2	14.7	16.2
NCDQ8□Z150-□	—	8.13	8.67	9.21	9.75	10.3	10.9	11.4	12.5	13.6	14.7	15.7	17.9	20.1	22.2	24.4
NCDQ8□Z200-□	—	12.4	13.2	14.0	14.8	15.6	16.4	17.2	18.8	20.4	22.0	23.5	26.7	29.9	33.1	36.2
NCDQ8□Z250-□	—	18.6	19.4	20.2	21.0	21.8	22.7	23.5	25.1	26.7	28.3	30.0	33.2	36.4	39.7	42.9
NCDQ8□Z300-□	—	25.9	27.1	28.3	29.5	30.6	31.8	33.0	35.3	37.7	40.0	42.3	47.0	51.7	56.4	61.1
NCDQ8□Z400-□	—	47.0	48.6	50.2	51.9	53.5	55.1	56.8	60.0	63.3	66.5	69.8	76.3	82.8	89.3	95.9

## Optional Weight

Unit: OZ

Bore size	Clevis
056(9/16")	0.71
075(3/4")	0.93
106(1 1/16")	1.64
150(1 1/2")	4.16
200(2")	6.04
250(2 1/2")	8.74
300(3")	14.57
400(4")	23.46

# Series NCQ8

## Allowable Kinetic Energy

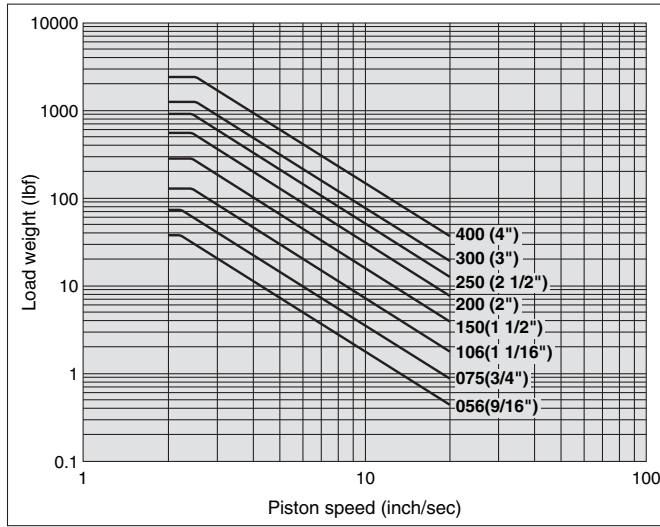

## Allowable lateral load at rod end

### Without Auto Switch

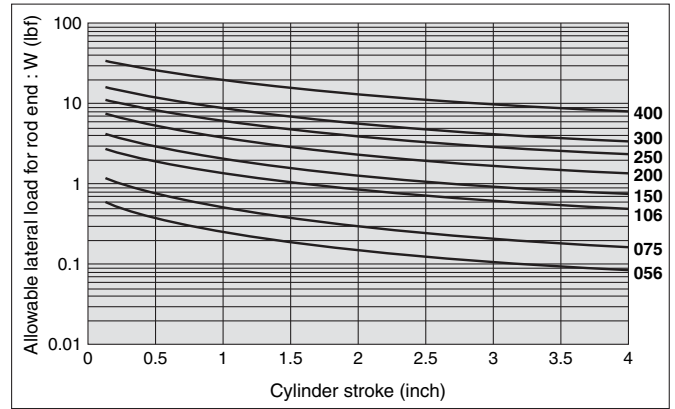

### With Auto Switch

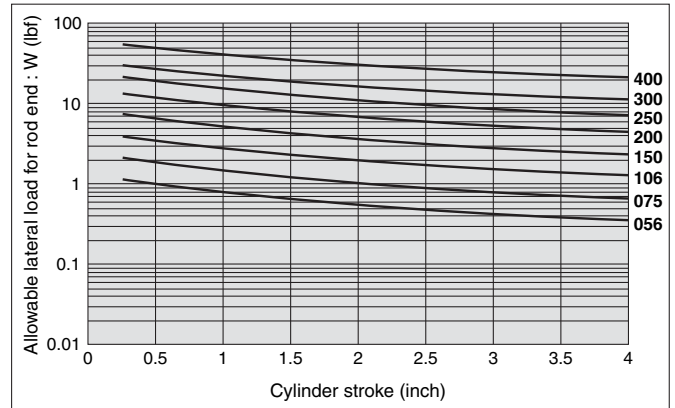

### With Auto Switch, Super Compact

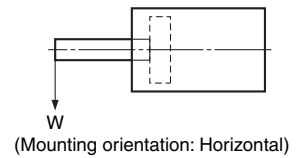
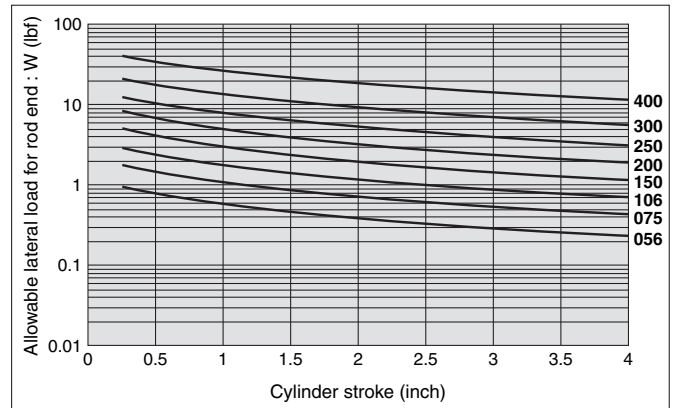

# Compact Cylinder Double Acting, Single Rod *Series NCQ8*

## Mounting Bolt

Mounting method: Mounting bolt for through-hole style of NCQ8B is available as an option.

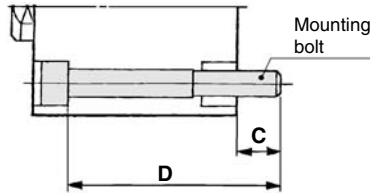

## Mounting Bolt Size for NCQ8B056 to 400-□(Without Auto Switch)

Model	C	D	Bolt size	
				order number
NCQ8B056-012	0.18	3/4	#4-40UNC-3/4	
025		7/8	7/8	
037		1	1	
050		1 1/8	1 1/8	
062		1 1/4	1 1/4	
075		1 3/8	1 3/8	
087		1 1/2	1 1/2	
100		1 5/8	1 5/8	
125		1 7/8	1 7/8	
150		2 1/8	2 1/8	
175		2 3/8	2 3/8	
200		2 5/8	2 5/8	
250		3 1/8	3 1/8	
300		3 5/8	3 5/8	
350		4 1/8	4 1/8	
400		4 5/8	4 5/8	
NCQ8B075-012	0.21	3/4	#6-32UNC-3/4	
025		7/8	7/8	
037		1	1	
050		1 1/8	1 1/8	
062		1 1/4	1 1/4	
075		1 3/8	1 3/8	
087		1 1/2	1 1/2	
100		1 5/8	1 5/8	
125		1 7/8	1 7/8	
150		2 1/8	2 1/8	
175		2 3/8	2 3/8	
200		2 5/8	2 5/8	
250		3 1/8	3 1/8	
300		3 5/8	3 5/8	
350		4 1/8	4 1/8	
400		4 5/8	4 5/8	
NCQ8B106-012	0.27	1 1/8	#6-32UNC-1 1/8	
025		1 1/4	1 1/4	
037		1 3/8	1 3/8	
050		1 1/2	1 1/2	
062		1 5/8	1 5/8	
075		1 3/4	1 3/4	
087		1 7/8	1 7/8	
100		2	2	
125		2 1/4	2 1/4	
150		2 1/2	2 1/2	
175		2 3/4	2 3/4	
200		3	3	
250		3 1/2	3 1/2	
300		4	4	
350		4 1/2	4 1/2	
400		5	5	

Model	C	D	Bolt size	
				order number
NCQ8B150-012	0.33	1 1/8	#10-24UNC-1 1/8	
025		1 1/4	1 1/4	
037		1 3/8	1 3/8	
050		1 1/2	1 1/2	
062		1 5/8	1 5/8	
075		1 3/4	1 3/4	
087		1 7/8	1 7/8	
100		2	2	
125		2 1/4	2 1/4	
150		2 1/2	2 1/2	
175		2 3/4	2 3/4	
200		3	3	
250		3 1/2	3 1/2	
300		4	4	
350		4 1/2	4 1/2	
400		5	5	
NCQ8B200-012	0.39	1 1/4	#10-24UNC-1 1/4	
025		1 3/8	1 3/8	
037		1 1/2	1 1/2	
050		1 5/8	1 5/8	
062		1 3/4	1 3/4	
075		1 7/8	1 7/8	
087		2	2	
100		2 1/8	2 1/8	
125		2 3/8	2 3/8	
150		2 5/8	2 5/8	
175		2 7/8	2 7/8	
200		3 1/8	3 1/8	
250		3 5/8	3 5/8	
300		4 1/8	4 1/8	
350		4 5/8	4 5/8	
400		5 1/8	5 1/8	
NCQ8B250-012	0.45	1 1/2	1/4-20UNC-1 1/2	
025		1 5/8	1 5/8	
037		1 3/4	1 3/4	
050		1 7/8	1 7/8	
062		2	2	
075		2 1/8	2 1/8	
087		2 1/4	2 1/4	
100		2 3/8	2 3/8	
125		2 5/8	2 5/8	
150		2 7/8	2 7/8	
175		3 1/8	3 1/8	
200		3 3/8	3 3/8	
250		3 7/8	3 7/8	
300		4 3/8	4 3/8	
350		4 7/8	4 7/8	
400		5 3/8	5 3/8	

Model	C	D	Bolt size	
				order number
NCQ8B300-012	0.39	1 1/2	1/4-20UNC-1 1/2	
025		1 5/8	1 5/8	
037		1 3/4	1 3/4	
050		1 7/8	1 7/8	
062		2	2	
075		2 1/8	2 1/8	
087		2 1/4	2 1/4	
100		2 3/8	2 3/8	
125		2 5/8	2 5/8	
150		2 7/8	2 7/8	
175		3 1/8	3 1/8	
200		3 3/8	3 3/8	
250		3 7/8	3 7/8	
300		4 3/8	4 3/8	
350		4 7/8	4 7/8	
400		5 3/8	5 3/8	
NCQ8B400-012	0.52	1 7/8	5/16-18UNC-1 7/8	
025		2	2	
037		2 1/8	2 1/8	
050		2 1/4	2 1/4	
062		2 3/8	2 3/8	
075		2 1/2	2 1/2	
087		2 5/8	2 5/8	
100		2 3/4	2 3/4	
125		3	3	
150		3 1/4	3 1/4	
175		3 1/2	3 1/2	
200		3 3/4	3 3/4	
250		4 1/4	4 1/4	
300		4 3/4	4 3/4	
350		5 1/4	5 1/4	
400		5 3/4	5 3/4	

# Series NCQ8

## Mounting Bolt

Mounting method: Mounting bolt for through-hole style of NCQ8 is available as an option.

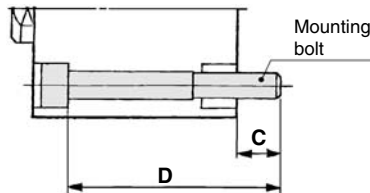

## Mounting Bolt Size for NCDQ8B056 to 400-□(With Auto Switch)

Model	C	D	Bolt size
			order number
<b>NCDQ8B056-025</b>	0.18	1 3/4	#4-40UNC-1 3/4
<b>037</b>		1 7/8	1 7/8
<b>050</b>		2	2
<b>062</b>		2 1/8	2 1/8
<b>075</b>		2 1/4	2 1/4
<b>087</b>		2 3/8	2 3/8
<b>100</b>		2 1/2	2 1/2
<b>125</b>		2 3/4	2 3/4
<b>150</b>		3	3
<b>175</b>		3 1/4	3 1/4
<b>200</b>		3 1/2	3 1/2
<b>250</b>		4	4
<b>300</b>		4 1/2	4 1/2
<b>350</b>		5	5
<b>400</b>		5 1/2	5 1/2
<b>NCDQ8B075-025</b>		0.21	1 3/4
<b>037</b>	1 7/8		1 7/8
<b>050</b>	2		2
<b>062</b>	2 1/8		2 1/8
<b>075</b>	2 1/4		2 1/4
<b>087</b>	2 3/8		2 3/8
<b>100</b>	2 1/2		2 1/2
<b>125</b>	2 3/4		2 3/4
<b>150</b>	3		3
<b>175</b>	3 1/4		3 1/4
<b>200</b>	3 1/2		3 1/2
<b>250</b>	4		4
<b>300</b>	4 1/2		4 1/2
<b>350</b>	5		5
<b>400</b>	5 1/2		5 1/2
<b>NCDQ8B106-025</b>	0.27		2 1/8
<b>037</b>		2 1/4	2 1/4
<b>050</b>		2 3/8	2 3/8
<b>062</b>		2 1/2	2 1/2
<b>075</b>		2 5/8	2 5/8
<b>087</b>		2 3/4	2 3/4
<b>100</b>		2 7/8	2 7/8
<b>125</b>		3 1/8	3 1/8
<b>150</b>		3 3/8	3 3/8
<b>175</b>		3 5/8	3 5/8
<b>200</b>		3 7/8	3 7/8
<b>250</b>		4 3/8	4 3/8
<b>300</b>		4 7/8	4 7/8
<b>350</b>		5 3/8	5 3/8
<b>400</b>		5 7/8	5 7/8

Model	C	D	Bolt size
			order number
<b>NCDQ8B150-025</b>	0.33	2 1/8	#10-24UNC-2 1/8
<b>037</b>		2 1/4	2 1/4
<b>050</b>		2 3/8	2 3/8
<b>062</b>		2 1/2	2 1/2
<b>075</b>		2 5/8	2 5/8
<b>087</b>		2 3/4	2 3/4
<b>100</b>		2 7/8	2 7/8
<b>125</b>		3 1/8	3 1/8
<b>150</b>		3 3/8	3 3/8
<b>175</b>		3 5/8	3 5/8
<b>200</b>		3 7/8	3 7/8
<b>250</b>		4 3/8	4 3/8
<b>300</b>		4 7/8	4 7/8
<b>350</b>		5 3/8	5 3/8
<b>400</b>		5 7/8	5 7/8
<b>NCDQ8B200-025</b>		0.39	2 1/4
<b>037</b>	2 3/8		2 3/8
<b>050</b>	2 1/2		2 1/2
<b>062</b>	2 5/8		2 5/8
<b>075</b>	2 3/4		2 3/4
<b>087</b>	2 7/8		2 7/8
<b>100</b>	3		3
<b>125</b>	3 1/4		3 1/4
<b>150</b>	3 1/2		3 1/2
<b>175</b>	3 3/4		3 3/4
<b>200</b>	4		4
<b>250</b>	4 1/2		4 1/2
<b>300</b>	5		5
<b>350</b>	5 1/2		5 1/2
<b>400</b>	6		6
<b>NCDQ8B250-025</b>	0.45		2 1/2
<b>037</b>		2 5/8	2 5/8
<b>050</b>		2 3/4	2 3/4
<b>062</b>		2 7/8	2 7/8
<b>075</b>		3	3
<b>087</b>		3 1/8	3 1/8
<b>100</b>		3 1/4	3 1/4
<b>125</b>		3 1/2	3 1/2
<b>150</b>		3 3/4	3 3/4
<b>175</b>		4	4
<b>200</b>		4 1/4	4 1/4
<b>250</b>		4 3/4	4 3/4
<b>300</b>		5 1/4	5 1/4
<b>350</b>		5 3/4	5 3/4
<b>400</b>		6 1/4	6 1/4

Model	C	D	Bolt size
			order number
<b>NCDQ8B300-025</b>	0.39	2 3/8	1/4-20UNC-2 3/8
<b>037</b>		2 1/2	2 1/2
<b>050</b>		2 5/8	2 5/8
<b>062</b>		2 3/4	2 3/4
<b>075</b>		2 7/8	2 7/8
<b>087</b>		3	3
<b>100</b>		3 1/8	3 1/8
<b>125</b>		3 3/8	3 3/8
<b>150</b>		3 5/8	3 5/8
<b>175</b>		3 7/8	3 7/8
<b>200</b>		4 1/8	4 1/8
<b>250</b>		4 5/8	4 5/8
<b>300</b>		5 1/8	5 1/8
<b>350</b>		5 5/8	5 5/8
<b>400</b>		6 1/8	6 1/8
<b>NCDQ8B400-025</b>		0.52	2 7/8
<b>037</b>	3		3
<b>050</b>	3 1/8		3 1/8
<b>062</b>	3 1/4		3 1/4
<b>075</b>	3 3/8		3 3/8
<b>087</b>	3 1/2		3 1/2
<b>100</b>	3 5/8		3 5/8
<b>125</b>	3 7/8		3 7/8
<b>150</b>	4 1/8		4 1/8
<b>175</b>	4 3/8		4 3/8
<b>200</b>	4 5/8		4 5/8
<b>250</b>	5 1/8		5 1/8
<b>300</b>	5 5/8		5 5/8
<b>350</b>	6 1/8		6 1/8
<b>400</b>	6 5/8		6 5/8



# Compact Cylinder Double Acting, Single Rod *Series NCQ8*

## Mounting Bolt

Mounting method: Mounting bolt for through-hole style of NCQ8 is available as an option.

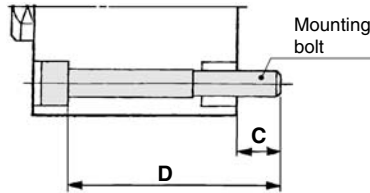

## Mounting Bolt size for NCDQ8BZ056 to 400-□(With Auto Switch, Super Compact)

Model	C	D	Bolt size
			order number
NCDQ8BZ056-025	0.18	1 3/8	#4-40UNC-1 3/8
037		1 1/2	1 1/2
050		1 5/8	1 5/8
062		1 3/4	1 3/4
075		1 7/8	1 7/8
087		2	2
100		2 1/8	2 1/8
125		2 3/8	2 3/8
150		2 5/8	2 5/8
175		2 7/8	2 7/8
200		3 1/8	3 1/8
250		3 5/8	3 5/8
300		4 1/8	4 1/8
350		4 5/8	4 5/8
400		5 1/8	5 1/8
NCDQ8BZ075-025		0.21	1 3/8
037	1 1/2		1 1/2
050	1 5/8		1 5/8
062	1 3/4		1 3/4
075	1 7/8		1 7/8
087	2		2
100	2 1/8		2 1/8
125	2 3/8		2 3/8
150	2 5/8		2 5/8
175	2 7/8		2 7/8
200	3 1/8		3 1/8
250	3 5/8		3 5/8
300	4 1/8		4 1/8
350	4 5/8		4 5/8
400	5 1/8		5 1/8
NCDQ8BZ106-025	0.27		1 5/8
037		1 3/4	1 3/4
050		1 7/8	1 7/8
062		2	2
075		2 1/8	2 1/8
087		2 1/4	2 1/4
100		2 3/8	2 3/8
125		2 5/8	2 5/8
150		2 7/8	2 7/8
175		3 1/8	3 1/8
200		3 3/8	3 3/8
250		3 7/8	3 7/8
300		4	4
350		4 1/2	4 1/2
400		5	5

Model	C	D	Bolt size
			order number
NCDQ8BZ150-025	0.33	1 5/8	#10-24UNC-1 5/8
037		1 3/4	1 3/4
050		1 7/8	1 7/8
062		2	2
075		2 1/8	2 1/8
087		2 1/4	2 1/4
100		2 3/8	2 3/8
125		2 5/8	2 5/8
150		2 7/8	2 7/8
175		3 1/8	3 1/8
200		3 3/8	3 3/8
250		3 7/8	3 7/8
300		4 3/8	4 3/8
350		4 7/8	4 7/8
400		5 3/8	5 3/8
NCDQ8BZ200-025		0.39	1 5/8
037	1 3/4		1 3/4
050	1 7/8		1 7/8
062	2		2
075	2 1/8		2 1/8
087	2 1/4		2 1/4
100	2 3/8		2 3/8
125	2 5/8		2 5/8
150	2 7/8		2 7/8
175	3 1/8		3 1/8
200	3 3/8		3 3/8
250	3 7/8		3 7/8
300	4 3/8		4 3/8
350	4 7/8		4 7/8
400	5 3/8		5 3/8
NCDQ8BZ250-025	0.45		1 7/8
037		2	2
050		2 1/8	2 1/8
062		2 1/4	2 1/4
075		2 3/8	2 3/8
087		2 1/2	2 1/2
100		2 5/8	2 5/8
125		2 7/8	2 7/8
150		3 1/8	3 1/8
175		3 3/8	3 3/8
200		3 5/8	3 5/8
250		4 1/8	4 1/8
300		4 5/8	4 5/8
350		5 1/8	5 1/8
400		5 5/8	5 5/8

Model	C	D	Bolt size
			order number
NCDQ8BZ300-025	0.39	1 7/8	1/4-20UNC-1 7/8
037		2	2
050		2 1/8	2 1/8
062		2 1/4	2 1/4
075		2 3/8	2 3/8
087		2 1/2	2 1/2
100		2 5/8	2 5/8
125		2 7/8	2 7/8
150		3 1/8	3 1/8
175		3 3/8	3 3/8
200		3 5/8	3 5/8
250		4 1/8	4 1/8
300		4 5/8	4 5/8
350		5 1/8	5 1/8
400		5 5/8	5 5/8
NCDQ8BZ400-025		0.52	2 1/4
037	2 3/8		2 3/8
050	2 1/2		2 1/2
062	2 5/8		2 5/8
075	2 3/4		2 3/4
087	2 7/8		2 7/8
100	3		3
125	3 1/4		3 1/4
150	3 1/2		3 1/2
175	3 3/4		3 3/4
200	4		4
250	4 1/2		4 1/2
300	5		5
350	5 1/2		5 1/2
400	6		6

# Series NCQ8

## Construction

Without auto switch

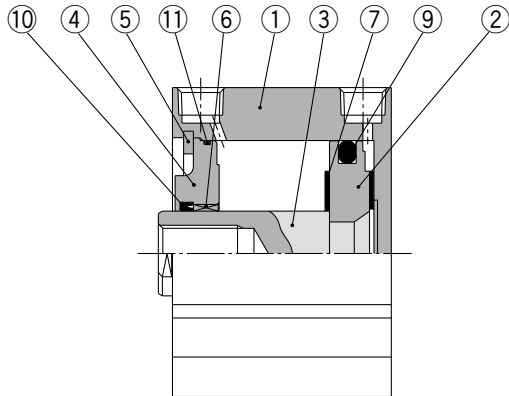

With auto switch

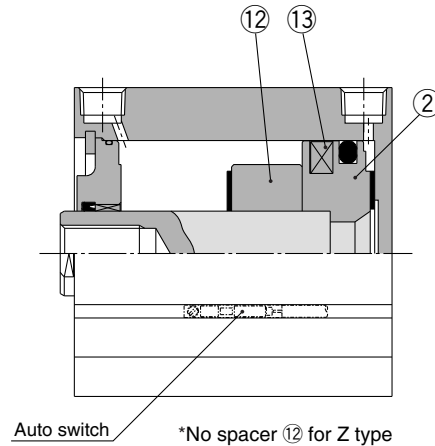

Male thread

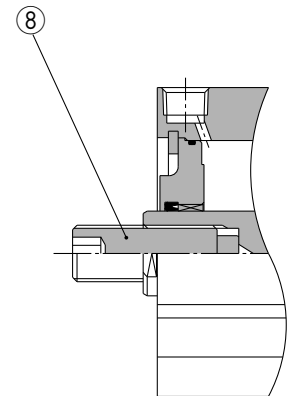

### Parts List

No.	Description	Material	Remarks
1	Cylinder tube	Aluminum alloy	Hard anodized
2	Piston	Aluminum alloy	Chromated
3	Piston rod	Stainless steel	056 to 106
		Carbon steel	150 to 400 Hard chrome plated
4	Collar	Aluminum alloy	Anodized
5	Snap ring	Carbon tool steel	Phosphate coated
6	Bushing	Phosphor bronze alloy	200 to 400
7	Rubber bumper	NBR	With rubber bumper only
8	Stud	Steel alloy	Electroless nickel plated
9	Piston seal	NBR	
10	Rod seal	NBR	
11	Tube gasket	NBR	
12	Spacer	Aluminum alloy	Chromated, Use for with auto switch type only(No spacer for Z type)
13	Magnet	—	

### Repair Parts: Standard Seal Kit for Double Acting, Single Rod

Bore size	Kit no.	Remarks
056(9/16")	NCQ8B056-PS	Piston seal, rod seal, and tube gasket are included.
075(3/4")	NCQ8B075-PS	
106(1 1/16")	NCQ8B106-PS	
150(1 1/2")	NCQ8B150-PS	
200(2")	NCQ8B200-PS	
250(2 1/2")	NCQ8B250-PS	
300(3")	NCQ8B300-PS	
400(4")	NCQ8B400-PS	

# Compact Cylinder Double Acting, Single Rod **Series NCQ8**

## Dimensions/NCQ8B056 to 400 [Without Auto switch]

### 056(9/16")

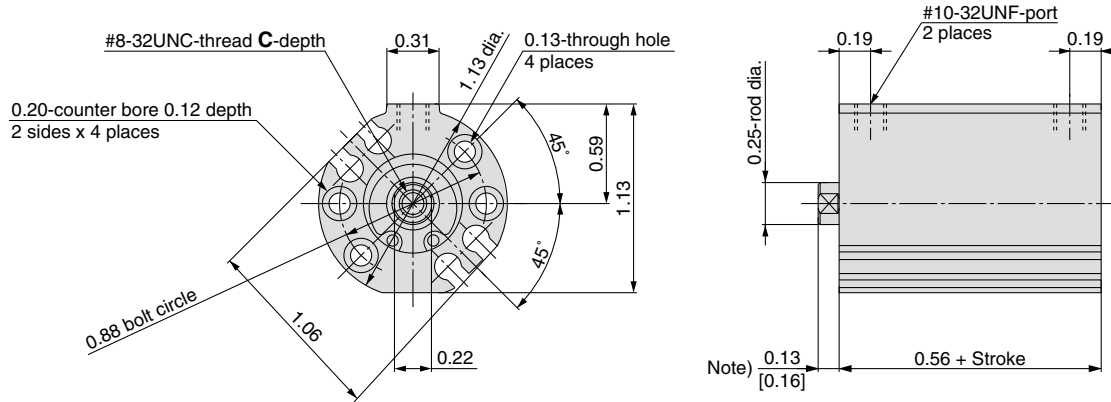

Symbol	C
Stroke	
1/8"	0.36
1/4" to 4"	0.46

Note) With rubber bumper type, the stroke is reduced by 0.06" and the rod extension is 0.16".

### 075(3/4"), 106(1 1/16"), 150(1 1/2"), 200(2"), 250(2 1/2"), 300(3"), 400(4")

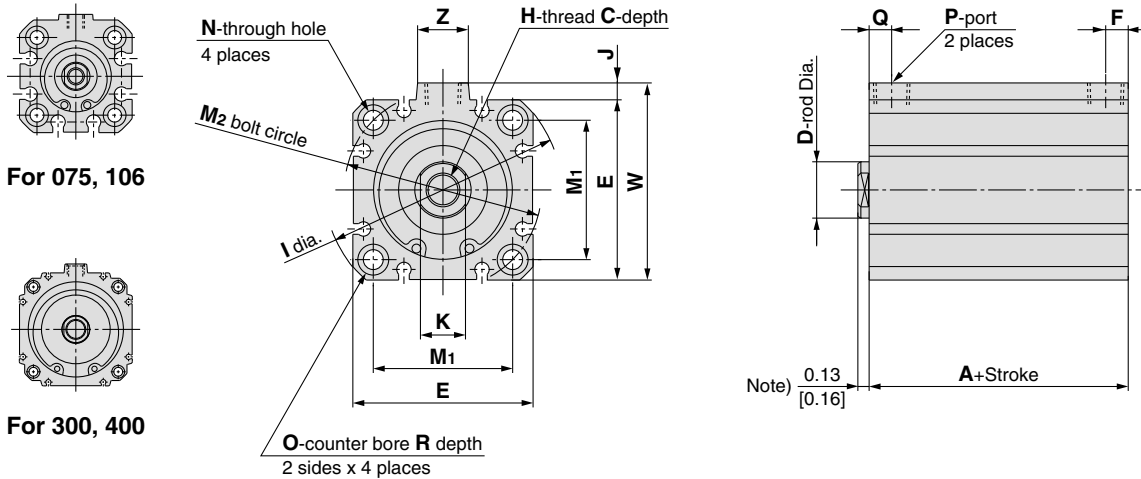

For 075, 106

For 300, 400

Symbol	A	C			D	E	F	H	I	J	K	M <sub>1</sub>	M <sub>2</sub>	N	O	P	Q	R	W	Z
		1/8"st	1/4"st	3/8" to 4"st																
<b>075(3/4")</b>	0.56	0.36	0.46	0.31	1.25	0.19	#10-32UNF	1.56	0.06	0.25	0.86	1.22	0.15	0.25	#10-32UNF	0.19	0.15	1.31	0.38	
<b>106(1 1/16")</b>	0.88	0.52	0.70	0.50	1.56	0.25	5/16-24UNF	2.03	0.16	0.44	1.19	1.69	0.15	0.25	NPT1/8	0.25	0.15	1.72	0.56	
<b>150(1 1/2")</b>	0.88	0.50	0.70	0.63	2.00	0.25	3/8-24UNF	2.63	0.19	0.50	1.55	2.19	0.22	0.34	NPT1/8	0.25	0.20	2.19	0.56	
<b>200(2")</b>	0.94	0.44	0.70	0.75	2.53	0.25	1/2-20UNF	3.13	0.20	0.63	1.90	2.69	0.22	0.34	NPT1/8	0.25	0.20	2.73	0.56	
<b>250(2 1/2")</b>	1.19	0.44	0.70	0.75	2.84	0.33	1/2-20UNF	3.75	0.39	0.63	2.30	3.25	0.28	0.41	NPT1/4	0.33	0.26	3.23	0.69	
<b>300(3")</b>	1.25	0.55	0.73	0.88	3.56	0.37	5/8-18UNF	4.25	0.28	0.75	2.67	3.78	0.28	0.41	NPT1/4	0.37	0.26	3.84	0.69	
<b>400(4")</b>	1.56	0.65	0.80	1.00	4.56	0.46	3/4-16UNF	5.50	0.41	0.88	3.49	4.94	0.34	0.50	NPT3/8	0.46	0.33	4.97	1.00	

Note) With rubber bumper type, the stroke is reduced by 0.06" and the rod extension is 0.16".

# Series NCQ8

## Dimensions/NCDQ8B(Z)056 to 400 [With Auto switch, Super compact]

### 056(9/16")

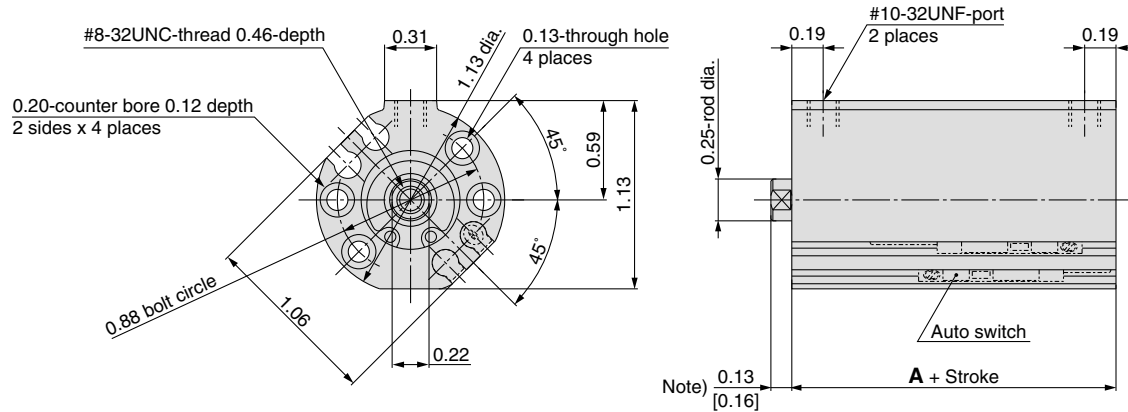

Symbol	A
Bore	
Standard	1.44
Super compact	1.06

Note) With rubber bumper type, the stroke is reduced by 0.06" and the rod extension is 0.16".

### 075(3/4"), 106(1 1/16"), 150(1 1/2"), 200(2"), 250(2 1/2"), 300(3"), 400(4")

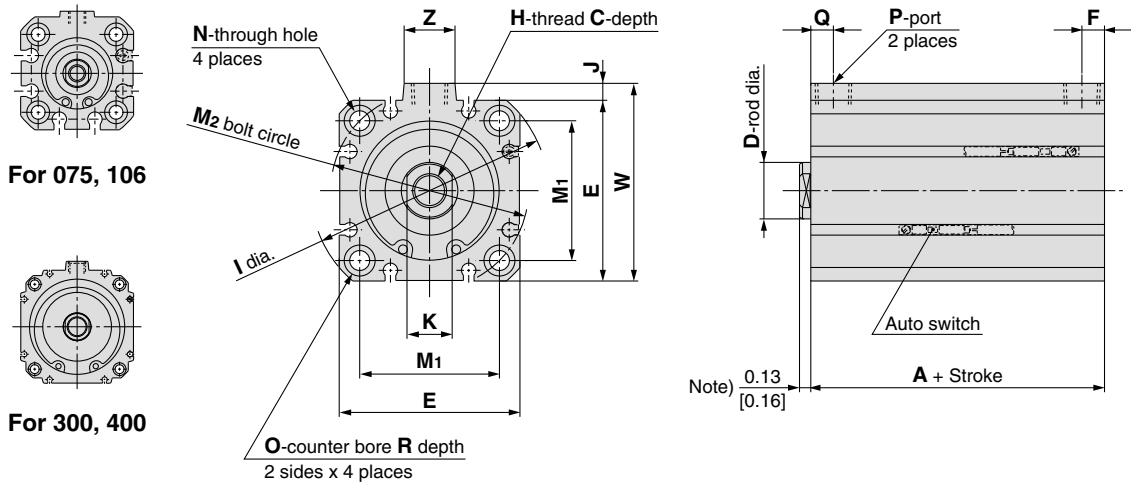

Symbol	A		C			D	E	F	H	I	J	K	M1	M2	N	O	P	Q	R	W	Z	
	Standard	Super compact	Standard	Super compact	Super compact																	
Bore				1/4"st	3/8"to4"st																	
075(3/4")	1.44	1.06		0.46		0.31	1.25	0.19	#10-32UNF	1.56	0.06	0.25	0.86	1.22	0.15	0.25	#10-32UNF	0.19	0.15	1.31	0.38	
106(1 1/16")	1.75	1.25	0.70	0.52	0.70	0.50	1.56	0.25	5/16-24UNF	2.03	0.16	0.44	1.19	1.69	0.15	0.25	NPT1/8	0.25	0.15	1.72	0.56	
150(1 1/2")	1.75	1.25	0.70	0.50	0.70	0.63	2.00	0.25	3/8-24UNF	2.63	0.19	0.50	1.55	2.19	0.22	0.34	NPT1/8	0.25	0.20	2.19	0.56	
200(2")	1.81	1.19		0.70		0.75	2.53	0.25	1/2-20UNF	3.13	0.20	0.63	1.90	2.69	0.22	0.34	NPT1/8	0.25	0.20	2.73	0.56	
250(2 1/2")	2.06	1.44		0.70		0.75	2.84	0.33	1/2-20UNF	3.75	0.39	0.63	2.30	3.25	0.28	0.41	NPT1/4	0.33	0.26	3.23	0.69	
300(3")	2.13	1.50		0.73		0.88	3.56	0.37	5/8-18UNF	4.25	0.28	0.75	2.67	3.78	0.28	0.41	NPT1/4	0.37	0.26	3.84	0.69	
400(4")	2.44	1.80		0.80		1.00	4.56	0.46	3/4-16UNF	5.50	0.41	0.88	3.49	4.94	0.34	0.50	NPT3/8	0.46	0.33	4.97	1.00	

Note) With rubber bumper type, the stroke is reduced by 0.06" and the rod extension is 0.16".

# Compact Cylinder Double Acting, Single Rod **Series NCQ8**

## Dimensions/Mounting

### Both ends tapped NC(D)Q8A□□-□(C)(M)

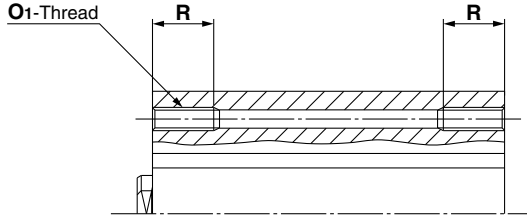

Symbol	O1	R
Bore		
056(9/16")	#4-40UNC	0.34
075(3/4")	#6-32UNC	0.34
106(1 1/16")	#6-32UNC	0.50
150(1 1/2")	#10-24UNC	0.50
200(2")	#10-24UNC	0.53
250(2 1/2")	1/4-20UNC	0.65
300(3")	1/4-20UNC	0.69
400(4")	5/16-18UNC	0.84

Note) Fully threaded tap for 012 stroke

### Rear clevis/NC(D)Q8C(Z)

056(9/16"), 075(3/4"), 106(1 1/16"), 150(1 1/2"), 200(2"), 250(2 1/2"), 300(3"), 400(4")

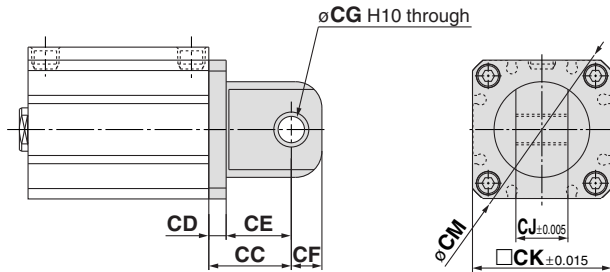

Symbol	CC	CD	CE	CF	CG	CJ	CK	CM
Bore								
056(9/16")	0.75	0.19	0.56	0.25	3/16	0.38	—	1.12
075(3/4")	0.75	0.19	0.56	0.25	3/16	0.38	1.25	1.56
106(1 1/16")	0.81	0.25	0.56	0.25	3/16	0.38	1.56	2.03
150(1 1/2")	1.19	0.25	0.94	0.44	3/8	0.75	2.00	2.62
200(2")	1.25	0.31	0.94	0.44	3/8	0.75	2.53	3.13
250(2 1/2")	1.31	0.38	0.93	0.44	3/8	0.75	2.84	3.74
300(3")	1.69	0.38	1.31	0.56	5/8	1.00	3.56	4.24
400(4")	1.75	0.44	1.31	0.56	5/8	1.00	4.56	5.49

### Screw clearance hole, front mount/ NC(D)Q8E(Z)

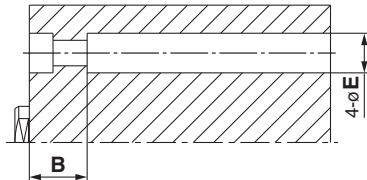

### Screw clearance hole, rear mount/ NC(D)Q8M(Z)

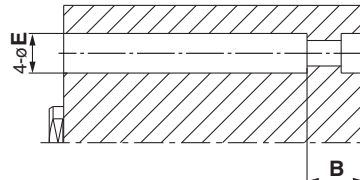

Symbol	B	E
Bore		
056(9/16")	0.34	0.20
075(3/4")	0.34	0.25
106(1 1/16")	0.50	0.25
150(1 1/2")	0.50	0.34
200(2")	0.53	0.34
250(2 1/2")	0.66	0.41
300(3")	0.69	0.41
400(4")	0.84	0.50

### Screw clearance hole, through/NC(D)Q8N(Z)

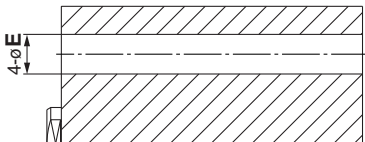

## Dimensions/Male rod end

### Male rod end NC(D)Q8□□□-□(C)M

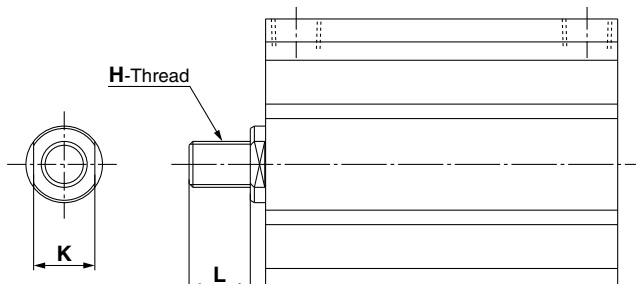

Symbol	H	L	K
Bore			
056(9/16")	#8-32UNC	0.38	0.22
075(3/4")	#10-32UNF	0.38	0.25
106(1 1/16")	5/16-24UNF	0.50	0.44
150(1 1/2")	3/8-24UNF	0.50	0.50
200(2")	1/2-20UNF	0.63	0.63
250(2 1/2")	1/2-20UNF	0.63	0.63
300(3")	5/8-18UNF	0.75	0.75
400(4")	3/4-16UNF	0.75	0.88

# Compact Cylinder Double Acting, Double Rod Series **NCQ8W**

Bore size: 056(9/16"), 075(3/4"), 106(1 1/16"), 150(1 1/2"), 200(2"), 250(2 1/2"), 300(3"), 400(4")

## How to Order

Without auto switch

NCQ8W B 056 - 025

With auto switch

NCDQ8W B 056 - 025 - M9BW S

Built-in magnet

Double rod

Mounting

B	Through-hole
A	Both ends tapped
E	Screw clearance hole, front mount
N	Screw clearance hole, rear mount

Nominal bore size

056	9/16"
075	3/4"
106	1 1/16"
150	1 1/2"
200	2"
250	2 1/2"
300	3"
400	4"

Cylinder stroke (in)

Symbol	Stroke (in)	Symbol	Stroke (in)	Symbol	Stroke (in)	Symbol	Stroke (in)
012	1/8"	062	5/8"	125	1 1/4"	250	2 1/2"
025	1/4"	075	3/4"	150	1 1/2"	300	3"
037	3/8"	087	7/8"	175	1 3/4"	350	3 1/2"
050	1/2"	100	1"	200	2"	400	4"

Note 1) With switch is available on strokes 025(1/4") and greater.

X-Option

Nil	Standard
XB6	High temp.
XC4	With scraper

Note 3) XB6: Not available with magnet.

\*Refer to page 36.

Number of auto switches

Nil	2 pcs.
S	1 pc.
n	"n" pcs.

Auto switch type

Nil	Without auto switch (Built-in magnet cylinder)
-----	--

\*Refer to the table below for auto switch model numbers.

\*Auto switches are shipped together, (but not assembled).

Body option

Nil	Standard (Female rod end)
C	Rubber bumper
M	Male rod end

Note 2) Stroke will be reduced by 0.06" for rubber bumper type.

\*Combination of body options(CM) is available.

## Applicable Auto Switches

Type	Special function	Electrical entry	Indicator/light	Wiring (output)	Load voltage		Auto switch model		Lead wire length (in)*				Applicable load		
					DC	AC	Perpendicular	In-line	20(0.5m) (Nil)	39(1m) (M)	118(3m) (L)	197(5m) (Z)	IC circuit	Relay, PLC	
															5 V, 12 V
Solid state switch	—	Grommet	—	3-wire (NPN)	24 V	5 V, 12 V	—	M9NV	M9N	●	—	●	○	—	—
				3-wire (PNP)				M9PV	M9P	●	—	●	○		
				2-wire				M9BV	M9B	●	—	●	○		
	Diagnostic indication (2-color display)	Grommet	Yes	3-wire (NPN)	24 V	5 V, 12 V	—	M9NVW	M9NW	●	●	●	○	—	—
				3-wire (PNP)				M9PVW	M9PW	●	●	●	○		
				2-wire				M9BWW	M9BW	●	●	●	○		
Reed switch	—	Grommet	—	3-wire (NPN equiv.)	24 V	5 V, 12 V	100 V	A96V	A96	●	—	●	—	—	—
				2-wire				A90V	A90	●	—	●	—		
				—				A93V	A93	●	—	●	—		

\*Lead wire length symbols: 20in (0.5 m)..... Nil  
39in (1 m)..... M  
118in (3 m)..... L  
197in (5 m)..... Z

(Example) M9NV  
M9NVW  
M9NW  
M9NWZ

\*Solid state switches marked with a "○" symbol are produced upon receipt of order.  
\*39 in (1 m: M): Available in the D-M9□W(V) only.

# Compact Cylinder Double Acting, Double Rod *Series NCQ8W*

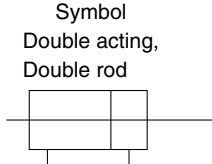

## Specifications

Bore size	056(9/16")	075(3/4")	106(1 1/16")	150(1 1/2")	200(2")	250(2 1/2")	300(3")	400(4")
Piping size	#10-32UNF	#10-32UNF	NPT1/8	NPT1/8	NPT1/8	NPT1/4	NPT1/4	NPT3/8
Type	Pneumatic (Non-lube)							
Action	Double acting, Double rod							
Fluid	Air							
Proof pressure	300PSI (2.1MPa)							
Maximum operating pressure	200PSI (1.4MPa)							
Minimum operating pressure	11PSI (0.07MPa)	8PSI (0.05MPa)						
Ambient and fluid temperature	Without auto switch	15 to 150°F (-10 to 65°C) (No freezing)						
	With auto switch	15 to 140°F (-10 to 60°C) (No freezing)						
Cushion	Rubber bumper (C)							
Rod end thread	Female thread							
Rod end thread tolerance	ANSI/ASME B 1.1-1989							
Stroke tolerance	0 to +0.04 in (+1.0mm)							
Mounting	Through-hole (B), Both ends tapped (A), Clevis, SCH (E,N)							
Piston speed	2 to 20in/sec (50 to 500mm/s)						2 to 11.8in/sec (50 to 300mm/s)	

## Applicable Stroke

Unit: inch

Bore size	Standard stroke
056(9/16")	
075(3/4")	012(1/8"), 025(1/4"), 037(3/8")
106(1 1/16")	050(1/2"), 062(5/8"), 075(3/4")
150(1 1/2")	087(7/8"), 100(1"), 125(1 1/4")
200(2")	150(1 1/2"), 175(1 3/4"), 200(2")
250(2 1/2")	250(2 1/2"), 300(3")
300(3")	350(3 1/2"), 400(4")
400(4")	

\* With switch is available on strokes 025(1/4") and greater.

## Theoretical Output Table

Unit: lbf

Bore size (in)	Operating pressure/PSI (MPa)			
	45(0.3)	75(0.5)	145(1.0)	200(1.4)
056(9/16")	8.87	14.6	28.6	39.2
075(3/4")	16.4	27.0	52.9	72.5
106(1 1/16")	30.8	50.8	99.5	136
150(1 1/2")	65.7	108	212	290
200(2")	121	200	391	536
250(2 1/2")	201	330	648	888
300(3")	278	463	927	1298
	304	506	1013	1418
400(4")	506	844	1689	2364
	540	900	1801	2522

## Weight Table

### Product's Weight (Double Acting, Double Rod, Without Switch)

(OZ)

Model	Stroke	012	025	037	050	062	075	087	100	125	150	175	200	250	300	350	400
		(1/8")	(1/4")	(3/8")	(1/2")	(5/8")	(3/4")	(7/8")	(1")	(1 1/4")	(1 1/2")	(1 3/4")	(2")	(2 1/2")	(3")	(3 1/2")	(4")
NCQ8W□056-□		1.33	1.39	1.46	1.52	1.69	1.86	2.03	2.20	2.54	2.88	3.21	3.55	4.23	4.91	5.58	6.26
NCQ8W□075-□		1.92	2.04	2.15	2.26	2.52	2.77	3.02	3.28	3.79	4.29	4.80	5.31	6.33	7.34	8.36	9.37
NCQ8W□106-□		3.71	4.14	4.56	4.99	5.42	5.84	6.34	6.84	7.83	8.83	9.82	10.9	12.8	14.8	16.8	18.8
NCQ8W□150-□		7.01	7.80	8.50	9.21	9.91	9.63	10.4	11.1	12.5	13.9	15.4	16.8	19.6	22.4	25.3	28.1
NCQ8W□200-□		12.9	13.7	14.5	15.4	16.2	17.0	16.5	17.3	19.0	20.7	22.3	24.0	27.3	30.6	33.9	37.2
NCQ8W□250-□		18.7	19.6	20.5	21.3	22.2	21.0	21.9	22.8	24.6	26.3	28.1	29.9	33.4	37.0	40.6	44.1
NCQ8W□300-□		22.7	24.3	25.9	27.4	29.0	30.5	31.6	33.1	35.9	39.1	42.2	45.3	51.6	57.8	64.0	70.2
NCQ8W□400-□		38.8	41.3	43.4	45.4	47.5	49.6	51.8	53.7	57.7	61.9	66.0	70.2	78.5	86.9	95.2	103.6

### Product's Weight (Double Acting, Double Rod, With Switch)

(OZ)

Model	Stroke	012	025	037	050	062	075	087	100	125	150	175	200	250	300	350	400
		(1/8")	(1/4")	(3/8")	(1/2")	(5/8")	(3/4")	(7/8")	(1")	(1 1/4")	(1 1/2")	(1 3/4")	(2")	(2 1/2")	(3")	(3 1/2")	(4")
NCDQ8W□056-□		—	2.70	2.76	2.72	2.89	3.06	3.23	3.40	3.74	4.08	4.41	4.75	5.43	6.11	6.78	7.46
NCDQ8W□075-□		—	4.22	4.34	4.24	4.49	4.75	5.00	5.25	5.76	6.27	6.78	7.28	8.30	9.32	10.4	11.4
NCDQ8W□106-□		—	8.19	8.62	9.04	9.47	9.19	9.69	10.2	11.2	12.2	13.2	14.2	16.2	18.2	20.2	22.2
NCDQ8W□150-□		—	17.3	18.0	18.7	19.4	15.5	16.2	16.9	18.3	19.8	21.2	22.6	25.4	28.3	31.1	33.9
NCDQ8W□200-□		—	33.3	34.2	35.0	35.8	36.6	24.7	25.5	27.2	28.8	30.5	32.2	35.5	38.8	42.1	45.4
NCDQ8W□250-□		—	50.0	50.9	51.7	52.6	31.2	32.0	32.9	34.7	36.5	38.3	40.0	43.6	47.2	50.7	54.3
NCDQ8W□300-□		—	54.1	55.5	56.9	58.3	60.0	61.5	63.1	66.2	69.3	72.4	75.5	81.7	87.9	94.1	100.3
NCDQ8W□400-□		—	83.4	85.3	87.1	89.0	91.3	93.4	95.5	99.6	103.8	108.0	112.1	120.5	128.8	137.2	145.5

# Series NCQ8W

## Allowable Kinetic Energy

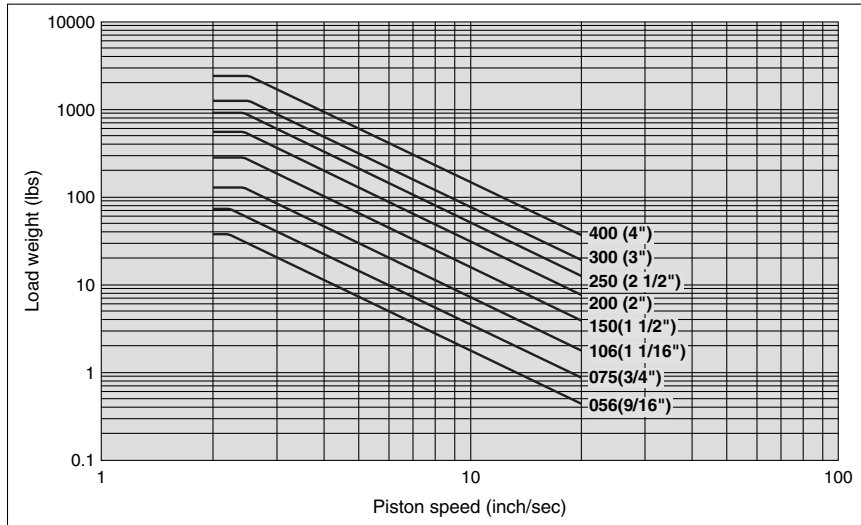

## Allowable lateral load at rod end

Without Auto Switch

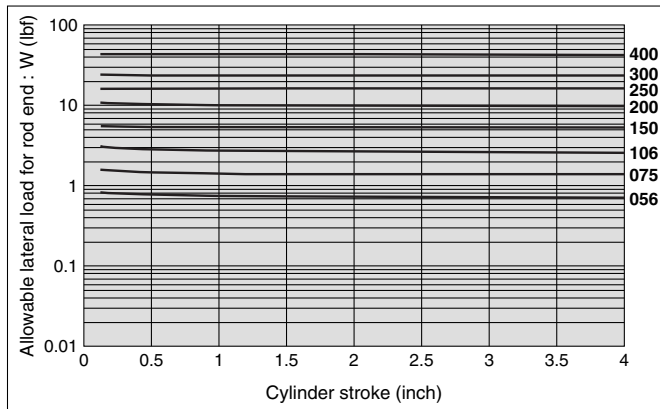

With Auto Switch

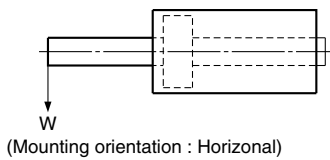
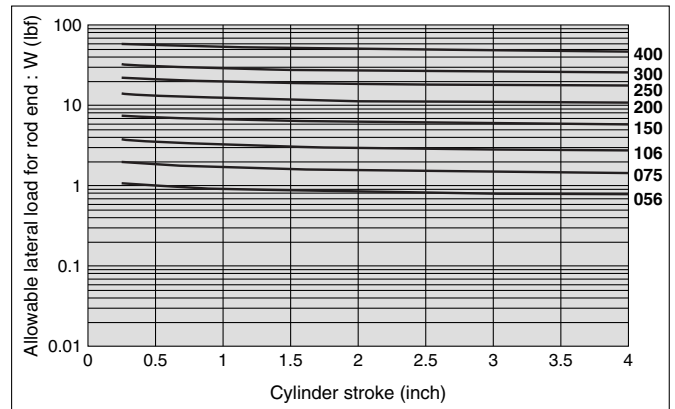



# Compact Cylinder Double Acting, Double Rod *Series NCQ8W*

## Mounting Bolt

Mounting method: Mounting bolt for through-hole style of NCQ8WB is available as an option.

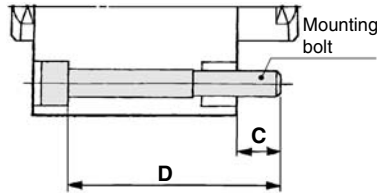

## Mounting Bolt Size for NCQ8WB056 to 400-□(Without Auto Switch)

Model	C	D	Bolt size	
				order number
NCQ8WB056-012	0.18	7/8	#4-40UNC-7/8	
025		1		1
037		1 1/8		1 1/8
050		1 1/4		1 1/4
062		1 3/8		1 3/8
075		1 1/2		1 1/2
087		1 5/8		1 5/8
100		1 3/4		1 3/4
125		2		2
150		2 1/4		2 1/4
175		2 1/2		2 1/2
200		2 3/4		2 3/4
250		3 1/4		3 1/4
300		3 3/4		3 3/4
350		4 1/4		4 1/4
400	4 3/4		4 3/4	
NCQ8WB075-012	0.21	7/8	#6-32UNC-7/8	
025		1		1
037		1 1/8		1 1/8
050		1 1/4		1 1/4
062		1 3/8		1 3/8
075		1 1/2		1 1/2
087		1 5/8		1 5/8
100		1 3/4		1 3/4
125		2		2
150		2 1/4		2 1/4
175		2 1/2		2 1/2
200		2 3/4		2 3/4
250		3 1/4		3 1/4
300		3 3/4		3 3/4
350		4 1/4		4 1/4
400	4 3/4		4 3/4	
NCQ8WB106-012	0.21	1 1/8	#6-32UNC-1 1/8	
025		1 1/4		1 1/4
037		1 3/8		1 3/8
050		1 1/2		1 1/2
062		1 5/8		1 5/8
075		1 3/4		1 3/4
087		1 7/8		1 7/8
100		2		2
125		2 1/4		2 1/4
150		2 1/2		2 1/2
175		2 3/4		2 3/4
200		3		3
250		3 1/2		3 1/2
300		4		4
350		4 1/2		4 1/2
400	5		5	

Model	C	D	Bolt size	
				order number
NCQ8WB150-012	0.33	1 1/4	#10-24UNC-1 1/4	
025		1 3/8		1 3/8
037		1 1/2		1 1/2
050		1 5/8		1 5/8
062		1 3/4		1 3/4
075		1 7/8		1 7/8
087		2		2
100		2 1/8		2 1/8
125		2 3/8		2 3/8
150		2 5/8		2 5/8
175		2 7/8		2 7/8
200		3 1/8		3 1/8
250		3 5/8		3 5/8
300		4 1/8		4 1/8
350		4 5/8		4 5/8
400	5 1/8		5 1/8	
NCQ8WB200-012	0.39	1 3/8	#10-24UNC-1 3/8	
025		1 1/2		1 1/2
037		1 5/8		1 5/8
050		1 3/4		1 3/4
062		1 7/8		1 7/8
075		2		2
087		2 1/8		2 1/8
100		2 1/4		2 1/4
125		2 1/2		2 1/2
150		2 3/4		2 3/4
175		3		3
200		3 1/4		3 1/4
250		3 3/4		3 3/4
300		4 1/4		4 1/4
350		4 3/4		4 3/4
400	5 1/4		5 1/4	
NCQ8WB250-012	0.45	1 5/8	1/4-20UNC-1 5/8	
025		1 3/4		1 3/4
037		1 7/8		1 7/8
050		2		2
062		2 1/8		2 1/8
075		2 1/4		2 1/4
087		2 3/8		2 3/8
100		2 1/2		2 1/2
125		2 3/4		2 3/4
150		3		3
175		3 1/4		3 1/4
200		3 1/2		3 1/2
250		4		4
300		4 1/2		4 1/2
350		5		5
400	5 1/2		5 1/2	

Model	C	D	Bolt size	
				order number
NCQ8WB300-012	0.38	1 5/8	1/4-20UNC-1 5/8	
025		1 3/4		1 3/4
037		1 7/8		1 7/8
050		2		2
062		2 1/8		2 1/8
075		2 1/4		2 1/4
087		2 3/8		2 3/8
100		2 1/2		2 1/2
125		2 3/4		2 3/4
150		3		3
175		3 1/4		3 1/4
200		3 1/2		3 1/2
250		4		4
300		4 1/2		4 1/2
350		5		5
400	5 1/2		5 1/2	
NCQ8WB400-012	0.52	2	5/16-18UNC-2	
025		2 1/8		2 1/8
037		2 1/4		2 1/4
050		2 3/8		2 3/8
062		2 1/2		2 1/2
075		2 5/8		2 5/8
087		2 3/4		2 3/4
100		2 7/8		2 7/8
125		3 1/8		3 1/8
150		3 3/8		3 3/8
175		3 5/8		3 5/8
200		3 7/8		3 7/8
250		4 3/8		4 3/8
300		4 7/8		4 7/8
350		5 3/8		5 3/8
400	5 7/8		5 7/8	

# Series NCQ8W

## Mounting Bolt

Mounting method: Mounting bolt for through-hole style of NCQ8WB is available as an option.

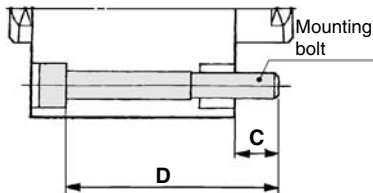

## Mounting Bolt Size for NCDQ8WB056 to 400-□(With Auto Switch)

Model	C	D	Bolt size
			order number
NCDQ8WB056-025	0.18	1 7/8	#4-40UNC-1 7/8
037		2	2
050		2 1/8	2 1/8
062		2 1/4	2 1/4
075		2 3/8	2 3/8
087		2 1/2	2 1/2
100		2 5/8	2 5/8
125		2 7/8	2 7/8
150		3 1/8	3 1/8
175		3 3/8	3 3/8
200		3 5/8	3 5/8
250		4 1/8	4 1/8
300		4 5/8	4 5/8
350		5 1/8	5 1/8
400		5 5/8	5 5/8
NCDQ8WB075-025		0.21	1 7/8
037	2		2
050	2 1/8		2 1/8
062	2 1/4		2 1/4
075	2 3/8		2 3/8
087	2 1/2		2 1/2
100	2 5/8		2 5/8
125	2 7/8		2 7/8
150	3 1/8		3 1/8
175	3 3/8		3 3/8
200	3 5/8		3 5/8
250	4 1/8		4 1/8
300	4 5/8		4 5/8
350	5 1/8		5 1/8
400	5 5/8		5 5/8
NCDQ8WB106-025	0.21		2 1/8
037		2 1/4	2 1/4
050		2 3/8	2 3/8
062		2 1/2	2 1/2
075		2 5/8	2 5/8
087		2 3/4	2 3/4
100		2 7/8	2 7/8
125		3 1/8	3 1/8
150		3 3/8	3 3/8
175		3 5/8	3 5/8
200		3 7/8	3 7/8
250		4 3/8	4 3/8
300		4 7/8	4 7/8
350		5 3/8	5 3/8
400		5 7/8	5 7/8

Model	C	D	Bolt size
			order number
NCDQ8WB150-025	0.33	2 1/4	#10-24UNC-2 1/4
037		2 3/8	2 3/8
050		2 1/2	2 1/2
062		2 5/8	2 5/8
075		2 3/4	2 3/4
087		2 7/8	2 7/8
100		3	3
125		3 1/4	3 1/4
150		3 1/2	3 1/2
175		3 3/4	3 3/4
200		4	4
250		4 1/2	4 1/2
300		5	5
350		5 1/2	5 1/2
400		6	6
NCDQ8WB200-025		0.39	2 3/8
037	2 1/2		2 1/2
050	2 5/8		2 5/8
062	2 3/4		2 3/4
075	2 7/8		2 7/8
087	3		3
100	3 1/8		3 1/8
125	3 3/8		3 3/8
150	3 5/8		3 5/8
175	3 7/8		3 7/8
200	4 1/8		4 1/8
250	4 5/8		4 5/8
300	5 1/8		5 1/8
350	5 5/8		5 5/8
400	6 1/8		6 1/8
NCDQ8WB250-025	0.45		2 5/8
037		2 3/4	2 3/4
050		2 7/8	2 7/8
062		3	3
075		3 1/8	3 1/8
087		3 1/4	3 1/4
100		3 3/8	3 3/8
125		3 5/8	3 5/8
150		3 7/8	3 7/8
175		4 1/8	4 1/8
200		4 3/8	4 3/8
250		4 7/8	4 7/8
300		5 3/8	5 3/8
350		5 7/8	5 7/8
400		6 3/8	6 3/8

Model	C	D	Bolt size
			order number
NCDQ8WB300-025	0.38	2 5/8	1/4-20UNC-2 5/8
037		2 3/4	2 3/4
050		2 7/8	2 7/8
062		3	3
075		3 1/8	3 1/8
087		3 1/4	3 1/4
100		3 3/8	3 3/8
125		3 7/8	3 7/8
150		3 7/8	3 7/8
175		4 1/8	4 1/8
200		4 3/8	4 3/8
250		4 7/8	4 7/8
300		5 3/8	5 3/8
350		5 7/8	5 7/8
400		6 3/8	6 3/8
NCDQ8WB400-025		0.52	3
037	3 1/8		3 1/8
050	3 1/4		3 1/4
062	3 3/8		3 3/8
075	3 1/2		3 1/2
087	3 5/8		3 5/8
100	3 3/4		3 3/4
125	4		4
150	4 1/4		4 1/4
175	4 1/2		4 1/2
200	4 3/4		4 3/4
250	5 1/4		5 1/4
300	5 3/4		5 3/4
350	6 1/4		6 1/4
400	6 3/4		6 3/4

# Compact Cylinder Double Acting, Double Rod *Series NCQ8W*

## Construction

**Without auto switch**

**With auto switch**

**Male thread**

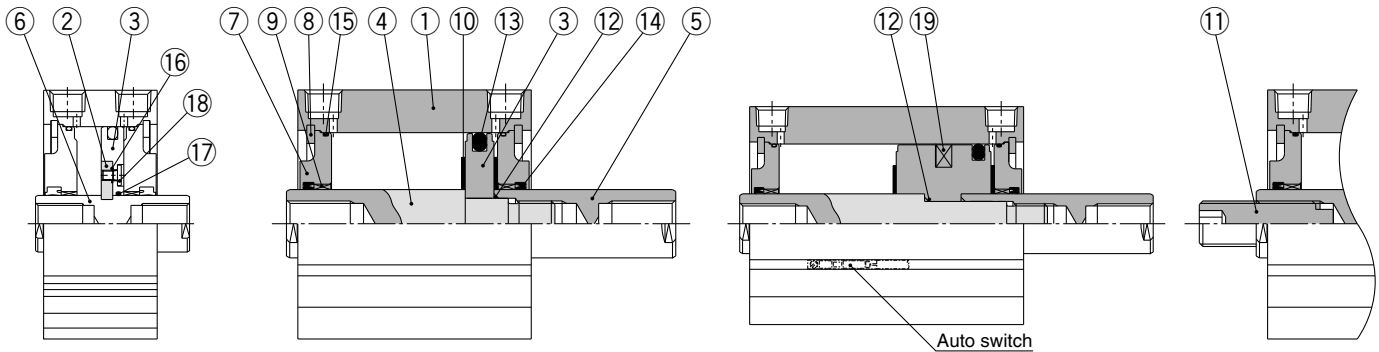

For stroke  
012(1/8")~075(3/4")

For stroke 087(7/8")~400(4")

### Parts List

No.	Description	Material	Remarks
1	<b>Cylinder tube</b>	Aluminum alloy	Hard anodized
2	<b>Piston Ring</b>	Stainless steel	300 and 400 only
3	<b>Piston</b>	Aluminum alloy	Chromated
4	<b>Piston Rod A</b>	Stainless steel	056 to 106
		Carbon steel	150 to 400, Hard chrome plated
5	<b>Piston Rod B</b>	Stainless steel	056 to 106
		Carbon steel	150 to 400, Hard chrome plated
6	<b>Piston Rod C</b>	Carbon steel	300 and 400 only
7	<b>Collar</b>	Aluminum alloy	Anodized
8	<b>Snap ring</b>	Carbon tool steel	Phosphate coated
9	<b>Bushing</b>	Phosphor bronze alloy	200 to 400
10	<b>Rubber bumper</b>	NBR	Use for with rubber bumper only
11	<b>Stud</b>	Steel alloy	Electroless nickel plated
12	<b>Piston gasket</b>	NBR	150 to 400
13	<b>Piston seal</b>	NBR	
14	<b>Rod seal</b>	NBR	
15	<b>Tube gasket</b>	NBR	
16	<b>Gasket</b>	NBR	300 and 400 only
17	<b>Gasket</b>	NBR	300 and 400 only
18	<b>Super low head cap bolt</b>	Carbon steel	300 and 400 only
19	<b>Magnet</b>	—	

### Repair Parts: Standard Seal Kit for Double Acting, Double Rod

Bore size	Kit no.	Remarks
<b>056(9/16")</b>	NCQ8WB056-PS	Piston seal, rod seal and tube gasket are included.
<b>075(3/4")</b>	NCQ8WB075-PS	
<b>106(1 1/16")</b>	NCQ8WB106-PS	
<b>150(1 1/2")</b>	NCQ8WB150-PS	
<b>200(2")</b>	NCQ8WB200-PS	
<b>250(2 1/2")</b>	NCQ8WB250-PS	
<b>300(3")</b>	NCQ8WB300-PS	
<b>400(4")</b>	NCQ8WB400-PS	

# Series NCQ8W

## Dimensions/NCQ8WB056 to 400 [Without Auto switch]

### 056(9/16")

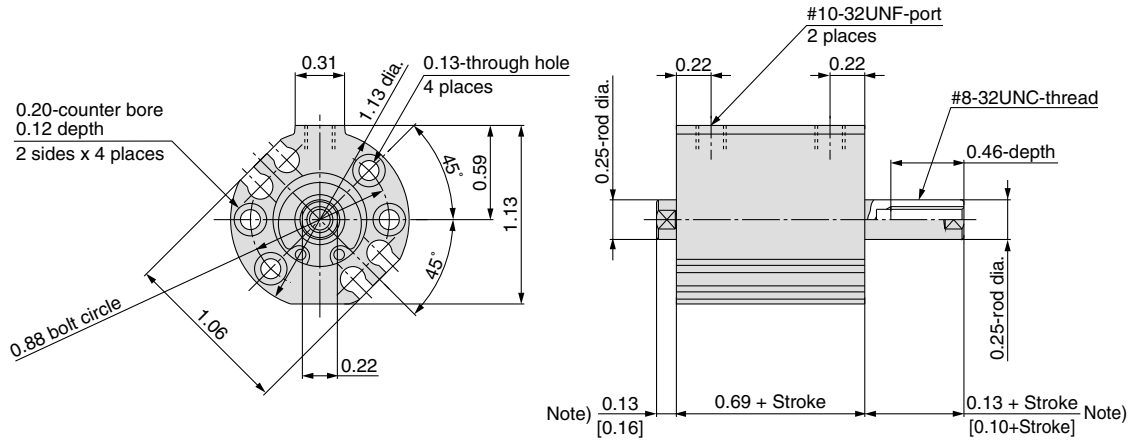

Note) With rubber bumper type, the stroke is reduced by 0.06" and the rod extension is 0.16".

### 075(3/4"), 106(1 1/16"), 150(1 1/2"), 200(2"), 250(2 1/2"), 300(3"), 400(4")

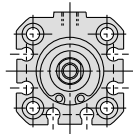

For 075, 106

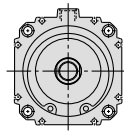

For 300, 400

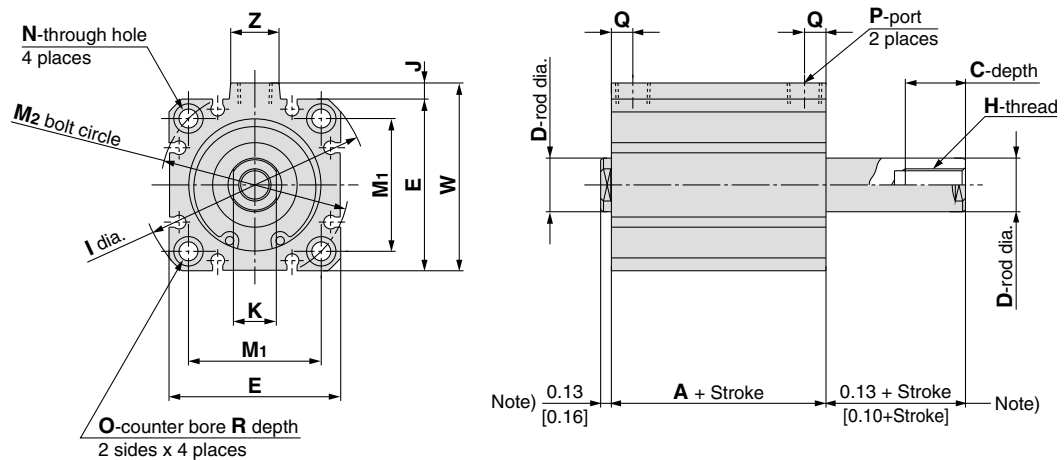

Symbol Bore	A	C	D	E	H	I	J	K	M <sub>1</sub>	M <sub>2</sub>	N	O	P	Q	R	W	Z
<b>075(3/4")</b>	0.69	0.46	0.31	1.25	#10-32UNF	1.56	0.06	0.25	0.86	1.22	0.15	0.25	#10-32UNF	0.22	0.15	1.31	0.38
<b>106(1 1/16")</b>	0.94	0.70	0.50	1.56	5/16-24UNF	2.03	0.16	0.44	1.19	1.69	0.15	0.25	NPT1/8	0.25	0.15	1.72	0.56
<b>150(1 1/2")</b>	1.00	0.70	0.63	2.00	3/8-24UNF	2.63	0.19	0.50	1.55	2.19	0.22	0.34	NPT1/8	0.25	0.20	2.19	0.56
<b>200(2")</b>	1.06	0.70	0.75	2.53	1/2-20UNF	3.13	0.20	0.63	1.90	2.69	0.22	0.34	NPT1/8	0.28	0.20	2.73	0.56
<b>250(2 1/2")</b>	1.31	0.70	0.75	2.84	1/2-20UNF	3.75	0.39	0.63	2.30	3.25	0.28	0.41	NPT1/4	0.33	0.26	3.23	0.69
<b>300(3")</b>	1.38	0.73	0.88	3.56	5/8-18UNF	4.25	0.28	0.75	2.67	3.78	0.28	0.41	NPT1/4	0.37	0.26	3.84	0.68
<b>400(4")</b>	1.69	0.80	1.00	4.56	3/4-16UNF	5.50	0.41	0.88	3.49	4.94	0.34	0.50	NPT3/8	0.46	0.33	4.97	1.00

Note) With rubber bumper type, the stroke is reduced by 0.06" and the rod extension is 0.16".

# Compact Cylinder Double Acting, Double Rod *Series NCQ8W*

## Dimensions/NCDQ8WB056 to 400 [With Auto switch]

### 056(9/16")

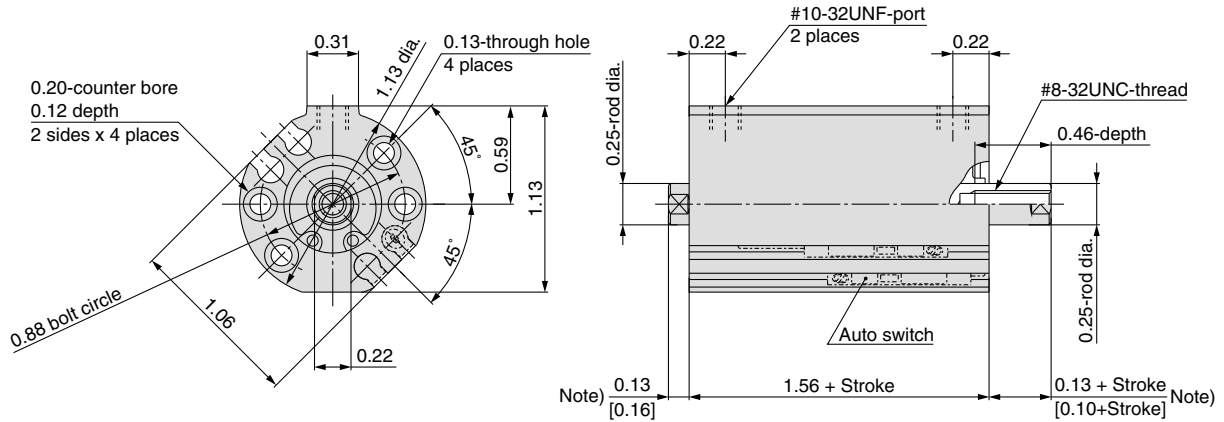

Note) With rubber bumper type, the stroke is reduced by 0.06" and the rod extension is 0.16".

### 075(3/4"), 106(1 1/16"), 150(1 1/2"), 200(2"), 250(2 1/2"), 300(3"), 400(4")

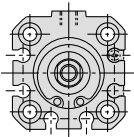

For 075, 106

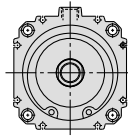

For 300, 400

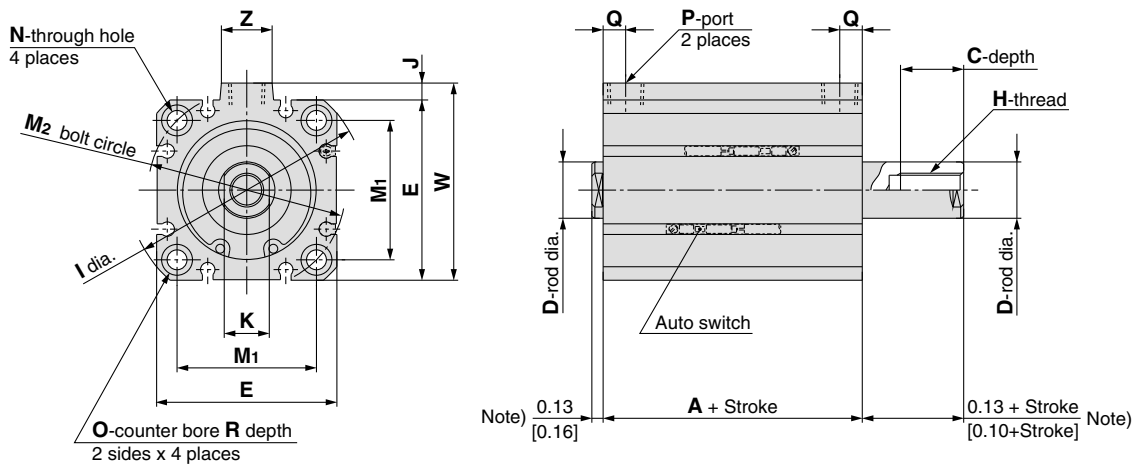

Symbol Bore	A	C	D	E	H	I	J	K	M <sub>1</sub>	M <sub>2</sub>	N	O	P	Q	R	W	Z
<b>075(3/4")</b>	1.56	0.46	0.31	1.25	#10-32UNF	1.56	0.06	0.25	0.86	1.22	0.15	0.25	#10-32UNF	0.22	0.15	1.31	0.38
<b>106(1 1/16")</b>	1.81	0.70	0.50	1.56	5/16-24UNF	2.03	0.16	0.44	1.19	1.69	0.15	0.25	NPT1/8	0.25	0.15	1.72	0.56
<b>150(1 1/2")</b>	1.88	0.70	0.63	2.00	3/8-24UNF	2.63	0.19	0.50	1.55	2.19	0.22	0.34	NPT1/8	0.25	0.20	2.19	0.56
<b>200(2")</b>	1.94	0.70	0.75	2.53	1/2-20UNF	3.13	0.20	0.63	1.90	2.69	0.22	0.34	NPT1/8	0.28	0.20	2.73	0.56
<b>250(2 1/2")</b>	2.19	0.70	0.75	2.84	1/2-20UNF	3.75	0.39	0.63	2.30	3.25	0.28	0.41	NPT1/4	0.33	0.26	3.23	0.69
<b>300(3")</b>	2.26	0.73	0.88	3.56	5/8-18UNF	4.25	0.28	0.75	2.67	3.78	0.28	0.41	NPT1/4	0.37	0.26	3.84	0.68
<b>400(4")</b>	2.57	0.80	1.00	4.56	3/4-16UNF	5.50	0.41	0.88	3.49	4.94	0.34	0.50	NPT3/8	0.46	0.33	4.97	1.00

Note) With rubber bumper type, the stroke is reduced by 0.06" and the rod extension is 0.16".

# Series NCQ8W

## Dimensions/NC(D)Q8W

### Both ends tapped NC(D)Q8WA-(C)(M)

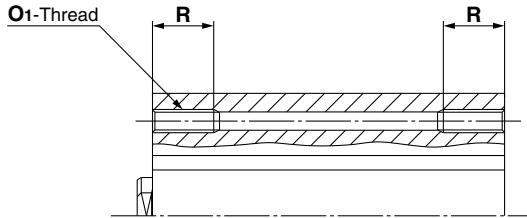

Symbol	O1	R
Bore		
056(9/16")	#4-40UNC	0.34
075(3/4")	#6-32UNC	0.34
106(1 1/16")	#6-32UNC	0.50
150(1 1/2")	#10-24UNC	0.50
200(2")	#10-24UNC	0.53
250(2 1/2")	1/4-20UNC	0.65
300(3")	1/4-20UNC	0.69
400(4")	5/16-18UNC	0.84

Note) Fully threaded tap for O12 stroke

### Screw clearance hole front mount/NC(D)Q8WE

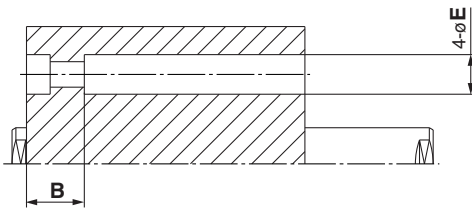

Symbol	B	E
Bore		
056(9/16")	0.34	0.20
075(3/4")	0.34	0.25
106(1 1/16")	0.50	0.25
150(1 1/2")	0.50	0.34
200(2")	0.53	0.34
250(2 1/2")	0.66	0.41
300(3")	0.69	0.41
400(4")	0.84	0.50

### Screw clearance hole rear mount/NC(D)Q8WN

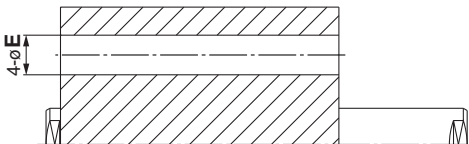

## Dimensions/Male rod end

### Male rod end NC(D)Q8W-(C)M

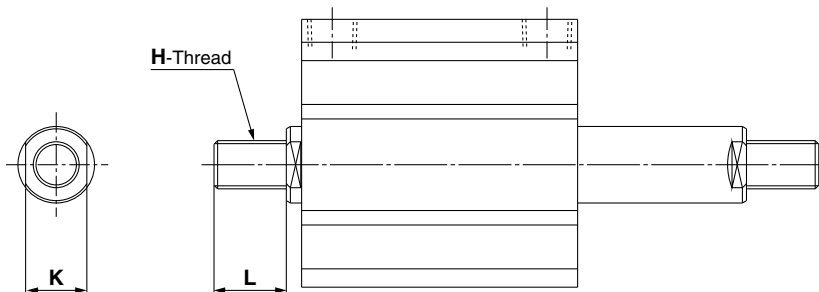

Symbol	H	L	K
Bore			
056(9/16")	#8-32UNC	0.38	0.22
075(3/4")	#10-32UNF	0.38	0.25
106(1 1/16")	5/16-24UNF	0.50	0.44
150(1 1/2")	3/8-24UNF	0.50	0.50
200(2")	1/2-20UNF	0.63	0.63
250(2 1/2")	1/2-20UNF	0.63	0.63
300(3")	5/8-18UNF	0.75	0.75
400(4")	3/4-16UNF	0.75	0.88

# Compact Cylinder Single Acting, Single Rod Series **NCQ8**

Bore size: 056(9/16"), 075(3/4"), 106(1 1/16"), 150(1 1/2"), 200(2"), 250(2 1/2")

## How to Order

Without auto switch

NCQ8 **B** **056** - **025** **S** **□**

With auto switch

NCDQ8 **B** **056** - **025** **S** **□** - **M9BW** **S**

Built-in magnet

Mounting

<b>B</b>	Through-hole
<b>A</b>	Both end tapped
<b>C</b>	Rear clevis
<b>E</b>	Screw clearance hole, front mount
<b>M</b>	Screw clearance hole, rear mount
<b>N</b>	Screw clearance hole, through

Overall length type

<b>Nil</b>	Standard
<b>Z</b>	Super Compact

Nominal bore size

<b>056</b>	9/16"
<b>075</b>	3/4"
<b>106</b>	1 1/16"
<b>150</b>	1 1/2"
<b>200</b>	2"
<b>250</b>	2 1/2"

Cylinder stroke (in)

Symbol	Stroke (in)	Symbol	Stroke (in)	Symbol	Stroke (in)
<b>012</b>	1/8"	<b>062</b>	5/8"	<b>125</b>	1 1/4"
<b>025</b>	1/4"	<b>075</b>	3/4"	<b>150</b>	1 1/2"
<b>037</b>	3/8"	<b>087</b>	7/8"	<b>175</b>	1 3/4"
<b>050</b>	1/2"	<b>100</b>	1"	<b>200</b>	2"

Note) With switch is available on strokes 025(1/4") and greater.

Number of auto switches

<b>Nil</b>	2 pcs.
<b>S</b>	1 pc.
<b>n</b>	"n" pcs.

Auto switch type

<b>Nil</b>	Without auto switch (Built-in magnet cylinder)
------------	---

\*Refer to the table below for auto switch model numbers.

\*Auto switches are shipped together, (but not assembled).

Body option

<b>Nil</b>	Standard (Female rod end)
<b>M</b>	Male rod end

Actuation

<b>S</b>	Single acting, Spring return
<b>T</b>	Single acting, Spring extend

## Applicable Auto Switches

Type	Special function	Electrical entry	Indicator light	Wiring (output)	Load voltage		Auto switch model		Lead wire length (in)*				Applicable load									
					DC	AC	Perpendicular	In-line	20(0.5m) (Nil)	39(1m) (M)	118(3m) (L)	197(5m) (Z)										
Solid state switch	—	Grommet	—	3-wire (NPN)	24 V	5 V, 12 V	—	<b>M9NV</b>	<b>M9N</b>	●	—	●	○	IC circuit	Relay, PLC							
				3-wire (PNP)				<b>M9PV</b>	<b>M9P</b>	●	—	●	○									
				2-wire				<b>M9BV</b>	<b>M9B</b>	●	—	●	○									
	Diagnostic indication (2-color display)	Grommet	Yes	3-wire (NPN)	24 V	5 V, 12 V	—	<b>M9N WV</b>	<b>M9N W</b>	●	●	●	○	IC circuit								
				3-wire (PNP)				<b>M9P WV</b>	<b>M9P W</b>	●	●	●	○									
				2-wire				<b>M9B WV</b>	<b>M9B W</b>	●	●	●	○									
Water resistant (2-color display)	—	Grommet	—	2-wire	24 V	12 V	—	—	<b>F9BA</b>	—	—	●	○	—								
								Reed switch	—	Grommet	Yes	3-wire (NPN equiv.)	24 V	5 V	—	<b>A96V</b>	<b>A96</b>	●	—	●	—	IC circuit
												No				2-wire	24 V	5 V, 12 V	100 V	<b>A90V</b>	<b>A90</b>	●
Yes	2-wire	24 V	12 V	<b>A93V</b>	<b>A93</b>	●	—													●	—	—

\*Lead wire length symbols: 20in (0.5 m)..... Nil  
39in (1 m)..... M  
118in (3 m)..... L  
197in (5 m)..... Z

(Example) M9N W  
M9N W M  
M9N W L  
M9N W Z

\*Solid state switches marked with a "○" symbol are produced upon receipt of order.  
\*39 in (1 m: M): Available in the D-M9□W(V) only.

# Series NCQ8

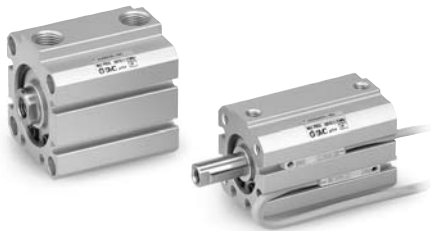

Symbol

Single acting,  
Single return

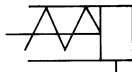

Single acting,  
Spring extend

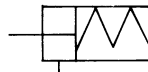

## Specifications

Bore size	056(9/16")	075(3/4")	106(1 1/16")	150(1 1/2")	200(2")	250(2 1/2")
Piping size	#10-32UNF	#10-32UNF	NPT1/8	NPT1/8	NPT1/8	NPT1/4
Type	Pneumatic (Non-lube)					
Fluid	Air					
Proof pressure	300PSI (2.1MPa)					
Maximum operating pressure	200PSI (1.4MPa)					
Minimum operating pressure	37PSI (0.25MPa)	26PSI (0.18MPa)	22PSI (0.15MPa)	19PSI (0.13MPa)		
Ambient and fluid temperature	Without auto switch	15 to 150°F(-10 to 65°C) (No freezing)				
	With auto switch	15 to 140°F(-10 to 60°C) (No freezing)				
Cushion	Not Available					
Rod end thread tolerance	ANSI/ASME B 1.1-1989					
Stroke tolerance	0 to +0.04 in (+1.0mm)					
Mounting	Through-hole (B), Both ends tapped (A)					
Piston speed	2 to 20in/sec (50 to 500mm/s)					

## Applicable Stroke

Unit: inch

Bore size	Standard stroke
056(9/16")	012(1/8"), 025(1/4"), 037(3/8"), 050(1/2") 062(5/8"), 075(3/4"), 087(7/8"), 100(1") 125(1 1/4"), 150(1 1/2"), 175(1 3/4"), 200(2")
075(3/4")	
106(1 1/16")	
150(1 1/2")	
200(2")	
250(2 1/2")	

\* With switch is available on strokes 025(1/4") and greater.

## Spring Reaction Force

Unit:lbf

Bore size (in)	Stroke	Spring reaction force	
		Inlet	Outlet
056(9/16")	012(1/8") to 100(1")	0.76	3.06
	125(1 1/4") to 200(2")	0.67	
075(3/4")	012(1/8") to 100(1")	1.42	3.42
	125(1 1/4") to 200(2")	1.33	
106(1 1/16")	012(1/8") to 100(1")	2.50	3.73
	125(1 1/4") to 200(2")	2.47	
150(1 1/2")	012(1/8") to 100(1")	4.00	6.79
	125(1 1/4") to 200(2")	4.09	
200(2")	012(1/8") to 100(1")	4.09	12.1
	125(1 1/4") to 200(2")	6.11	
250(2 1/2")	012(1/8") to 100(1")	7.53	14.7
	125(1 1/4") to 200(2")	13.9	

## Theoretical Output Table

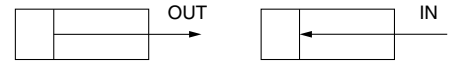

### Single Acting, Spring Return

Unit:lbf

Bore size (in)	Pressure (MPa)			
	45(0.3)	75(0.5)	145(1.0)	200(1.4)
056(9/16")	8.02	15.2	32.7	45.9
075(3/4")	16.4	29.3	60.6	84.4
106(1 1/16")	35.9	61.5	124	171
150(1 1/2")	72.7	124	249	344
200(2")	129	220	443	612
250(2 1/2")	206	348	697	961

### Single Acting, Spring Extend

Unit:lbf

Bore size (in)	Pressure (MPa)			
	45(0.3)	75(0.5)	145(1.0)	200(1.4)
056(9/16")	5.81	11.5	25.5	36.1
075(3/4")	13.0	23.6	49.5	69.1
106(1 1/16")	27.1	47.0	95.8	133
150(1 1/2")	58.9	101	205	283
200(2")	109	188	379	524
250(2 1/2")	186	316	633	873

## Optional Weight

Unit: OZ

Bore size(in)	Clevis
056(9/16")	0.71
075(3/4")	0.93
106(1 1/16")	1.64
150(1 1/2")	4.16
200(2")	6.04
250(2 1/2")	8.74



# Compact Cylinder Single Acting, Single Rod *Series NCQ8*

## Weight Table

**Product's Weight (Single Acting, Spring Return, Without Auto Switch)**

(OZ)

Model \ Stroke	012 (1/8")	025 (1/4")	037 (3/8")	050 (1/2")	062 (5/8")	075 (3/4")	087 (7/8")	100 (1")	125 (1 1/4")	150 (1 1/2")	175 (1 3/4")	200 (2")
NCQ8□056-□S	1.20	1.35	1.49	1.63	1.77	1.91	2.05	2.19	3.25	3.53	3.81	4.10
NCQ8□075-□S	1.87	2.08	2.29	2.50	2.71	2.91	3.12	3.29	4.10	4.52	4.93	4.36
NCQ8□106-□S	3.37	3.74	4.11	4.48	4.85	5.22	5.60	5.97	9.49	10.3	11.0	11.8
NCQ8□150-□S	6.35	6.89	7.43	7.97	8.51	9.05	9.59	10.2	15.5	16.6	17.6	18.7
NCQ8□200-□S	8.98	9.77	10.6	11.4	12.2	13.0	13.8	14.6	16.2	17.8	19.3	20.9
NCQ8□250-□S	14.5	15.3	16.1	16.9	17.7	18.5	19.4	20.2	21.8	23.4	25.0	26.9

**Product's Weight (Single Acting, Spring Return, With Auto Switch)**

(OZ)

Model \ Stroke	012 (1/8")	025 (1/4")	037 (3/8")	050 (1/2")	062 (5/8")	075 (3/4")	087 (7/8")	100 (1")	125 (1 1/4")	150 (1 1/2")	175 (1 3/4")	200 (2")
NCDQ8□056-□S	—	2.53	2.67	2.81	2.95	3.09	3.23	3.37	4.43	4.71	5.00	5.28
NCDQ8□075-□S	—	3.99	4.20	4.40	4.61	4.82	5.03	5.22	6.00	6.42	6.84	6.27
NCDQ8□106-□S	—	7.09	7.46	7.83	8.21	8.58	8.95	9.32	12.9	13.6	14.4	15.1
NCDQ8□150-□S	—	12.6	13.1	13.6	14.2	14.7	15.3	15.8	21.1	22.2	23.3	24.3
NCDQ8□200-□S	—	18.0	18.8	19.6	20.4	21.2	22.0	22.7	24.3	25.9	27.5	29.1
NCDQ8□250-□S	—	25.5	26.3	27.1	27.9	28.7	29.5	30.3	32.0	33.6	35.2	36.8

**Product's Weight (Single Acting, Spring Return, With Auto Switch, Super Compact)**

(OZ)

Model \ Stroke	012 (1/8")	025 (1/4")	037 (3/8")	050 (1/2")	062 (5/8")	075 (3/4")	087 (7/8")	100 (1")	125 (1 1/4")	150 (1 1/2")	175 (1 3/4")	200 (2")
NCDQ8□Z056-□S	—	2.00	2.14	2.28	2.42	2.56	2.70	2.84	3.90	4.18	4.47	4.75
NCDQ8□Z075-□S	—	3.16	3.37	3.57	3.78	3.99	4.20	4.41	5.18	5.59	6.01	5.44
NCDQ8□Z106-□S	—	5.15	5.52	5.90	6.27	6.64	7.01	7.38	10.9	11.7	12.4	13.2
NCDQ8□Z150-□S	—	9.19	9.73	10.3	10.9	11.4	11.9	12.5	17.8	18.9	19.9	21.0
NCDQ8□Z200-□S	—	12.6	13.4	14.2	15.0	15.8	16.6	17.4	19.0	20.5	22.1	23.7
NCDQ8□Z250-□S	—	18.8	19.6	20.4	21.2	22.1	22.9	23.7	25.3	26.9	28.5	30.2

**Product's Weight (Single Acting, Spring Extend, Without Auto Switch)**

(OZ)

Model \ Stroke	012 (1/8")	025 (1/4")	037 (3/8")	050 (1/2")	062 (5/8")	075 (3/4")	087 (7/8")	100 (1")	125 (1 1/4")	150 (1 1/2")	175 (1 3/4")	200 (2")
NCQ8□056-□T	1.42	1.56	1.70	1.84	1.98	2.12	2.26	2.40	3.34	3.62	3.90	4.18
NCQ8□075-□T	2.19	2.40	2.61	2.82	3.02	3.23	3.44	3.65	5.02	5.43	5.85	4.36
NCQ8□106-□T	4.96	5.33	5.70	6.07	6.44	6.81	7.18	7.55	10.3	11.0	11.8	12.5
NCQ8□150-□T	8.12	8.66	9.20	9.74	10.3	10.9	11.4	11.9	16.3	17.4	18.5	19.5
NCQ8□200-□T	12.2	13.0	13.8	14.6	15.4	16.2	17.0	17.8	19.4	20.9	22.5	24.1
NCQ8□250-□T	20.6	21.4	22.2	23.0	23.8	24.6	25.5	26.3	27.9	29.5	31.1	33.0

**Product's Weight (Single Acting, Spring Extend, With Auto Switch)**

(OZ)

Model \ Stroke	012 (1/8")	025 (1/4")	037 (3/8")	050 (1/2")	062 (5/8")	075 (3/4")	087 (7/8")	100 (1")	125 (1 1/4")	150 (1 1/2")	175 (1 3/4")	200 (2")
NCDQ8□056-□T	—	2.74	2.88	3.02	3.16	3.30	3.44	3.58	4.52	4.80	5.08	5.37
NCDQ8□075-□T	—	4.37	4.58	4.73	5.00	5.21	5.42	5.58	6.39	6.81	7.22	6.27
NCDQ8□106-□T	—	8.68	9.05	9.42	9.79	10.2	10.6	10.9	13.6	14.4	15.1	15.9
NCDQ8□150-□T	—	13.2	13.7	14.2	14.8	15.3	15.9	16.4	20.7	21.8	22.9	24.0
NCDQ8□200-□T	—	21.1	21.9	22.7	23.5	24.2	25.0	25.8	27.4	29.0	30.6	32.2
NCDQ8□250-□T	—	31.6	32.4	33.2	34.0	34.8	35.6	36.4	38.1	39.7	41.3	42.9

**Product's Weight (Single Acting, Spring Extend, With Auto Switch, Super Compact)**

(OZ)

Model \ Stroke	012 (1/8")	025 (1/4")	037 (3/8")	050 (1/2")	062 (5/8")	075 (3/4")	087 (7/8")	100 (1")	125 (1 1/4")	150 (1 1/2")	175 (1 3/4")	200 (2")
NCDQ8□Z056-□T	—	2.21	2.35	2.49	2.63	2.77	2.91	3.06	3.99	4.27	4.55	4.84
NCDQ8□Z075-□T	—	3.55	3.75	3.96	4.17	4.38	4.59	4.79	5.56	5.98	6.40	5.44
NCDQ8□Z106-□T	—	6.74	7.11	7.48	7.85	8.22	8.59	8.96	11.7	12.4	13.2	13.9
NCDQ8□Z150-□T	—	10.9	11.5	12.0	12.5	13.1	13.6	14.2	18.5	19.6	20.7	21.8
NCDQ8□Z200-□T	—	15.7	16.5	17.3	18.1	18.9	19.7	20.5	22.1	23.7	25.3	26.9
NCDQ8□Z250-□T	—	24.9	25.7	26.5	27.3	28.2	29.0	29.8	31.4	33.0	34.6	36.3

# Series NCQ8

## Mounting Bolt

Mounting method: Mounting bolt for through-hole style of NCQ8B is available as an option.

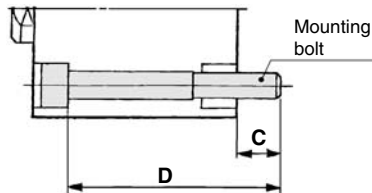

## Mounting Bolt Size for NCQ8B056 to 250-□S(Without Auto switch)

Model	C	D	Bolt size order number	
<b>NCQ8B056-012S</b>	0.18	1	#4-40UNC-1	
<b>025S</b>		1 1/8	1 1/8	
<b>037S</b>		1 1/4	1 1/4	
<b>050S</b>		1 3/8	1 3/8	
<b>062S</b>		1 1/2	1 1/2	
<b>075S</b>		1 5/8	1 5/8	
<b>087S</b>		1 3/4	1 3/4	
<b>100S</b>		1 7/8	1 7/8	
<b>125S</b>		2 3/4	2 3/4	
<b>150S</b>		3	3	
<b>175S</b>	0.25	3 1/4	3 1/4	
<b>200S</b>		3 1/2	3 1/2	
<b>NCQ8B075-012S</b>		1	#6-32UNC-1	
<b>025S</b>	0.21	1 1/8	1 1/8	
<b>037S</b>		1 1/4	1 1/4	
<b>050S</b>		1 3/8	1 3/8	
<b>062S</b>		1 1/2	1 1/2	
<b>075S</b>		1 5/8	1 5/8	
<b>087S</b>		1 3/4	1 3/4	
<b>100S</b>		1 7/8	1 7/8	
<b>125S</b>		2 3/4	2 3/4	
<b>150S</b>		0.27	3	3
<b>175S</b>			3 1/4	3 1/4
<b>200S</b>	3 1/2		3 1/2	
<b>NCQ8B106-012S</b>	0.27	1 1/8	#6-32UNC-1 1/8	
<b>025S</b>		1 1/4	1 1/4	
<b>037S</b>		1 3/8	1 3/8	
<b>050S</b>		1 1/2	1 1/2	
<b>062S</b>		1 5/8	1 5/8	
<b>075S</b>		1 3/4	1 3/4	
<b>087S</b>		1 7/8	1 7/8	
<b>100S</b>		2	2	
<b>125S</b>		2 7/8	2 7/8	
<b>150S</b>		3 1/8	3 1/8	
<b>175S</b>		3 3/8	3 3/8	
<b>200S</b>		3 5/8	3 5/8	

Model	C	D	Bolt size order number
<b>NCQ8B150-012S</b>	0.33	1 1/8	#10-24UNC-1 1/8
<b>025S</b>		1 1/4	1 1/4
<b>037S</b>		1 3/8	1 3/8
<b>050S</b>		1 1/2	1 1/2
<b>062S</b>		1 5/8	1 5/8
<b>075S</b>		1 3/4	1 3/4
<b>087S</b>		1 7/8	1 7/8
<b>100S</b>		2	2
<b>125S</b>		3	3
<b>150S</b>		0.45	3 1/4
<b>175S</b>	3 1/2		3 1/2
<b>200S</b>	3 3/4		3 3/4
<b>NCQ8B200-012S</b>	0.39	1 1/4	#10-24UNC-1 1/4
<b>025S</b>		1 3/8	1 3/8
<b>037S</b>		1 1/2	1 1/2
<b>050S</b>		1 5/8	1 5/8
<b>062S</b>		1 3/4	1 3/4
<b>075S</b>		1 7/8	1 7/8
<b>087S</b>		2	2
<b>100S</b>		2 1/8	2 1/8
<b>125S</b>		3	3
<b>150S</b>		3 1/4	3 1/4
<b>175S</b>	0.45	3 1/2	3 1/2
<b>200S</b>		3 3/4	3 3/4
<b>NCQ8B250-012S</b>		1 1/2	1/4-20UNC-1 1/2
<b>025S</b>	1 5/8	1 5/8	
<b>037S</b>	1 3/4	1 3/4	
<b>050S</b>	1 7/8	1 7/8	
<b>062S</b>	2	2	
<b>075S</b>	2 1/8	2 1/8	
<b>087S</b>	2 1/4	2 1/4	
<b>100S</b>	2 3/8	2 3/8	
<b>125S</b>	3 1/2	3 1/2	
<b>150S</b>	3 3/4	3 3/4	
<b>175S</b>	4	4	
<b>200S</b>	4 1/4	4 1/4	

# Compact Cylinder Single Acting, Single Rod **Series NCQ8**

## Mounting Bolt Size for NCDQ8B056 to 250-□S(With Auto switch)

Model	C	D	Bolt size
			order number
<b>NCDQ8B056-025S</b>	0.18	1 3/4	#4-40UNC-1 3/4
<b>037S</b>		1 7/8	1 7/8
<b>050S</b>		2	2
<b>062S</b>		2 1/8	2 1/8
<b>075S</b>		2 1/4	2 1/4
<b>087S</b>		2 3/8	2 3/8
<b>100S</b>		2 1/2	2 1/2
<b>125S</b>		3 3/8	3 3/8
<b>150S</b>		3 5/8	3 5/8
<b>175S</b>		3 7/8	3 7/8
<b>200S</b>	4 1/8	4 1/8	
<b>NCDQ8B075-025S</b>	0.21	2	#6-32UNC-2
<b>037S</b>		2 1/8	2 1/8
<b>050S</b>		2 1/4	2 1/4
<b>062S</b>		2 3/8	2 3/8
<b>075S</b>		2 1/2	2 1/2
<b>087S</b>		2 5/8	2 5/8
<b>100S</b>		2 3/4	2 3/4
<b>125S</b>		3 5/8	3 5/8
<b>150S</b>		3 7/8	3 7/8
<b>175S</b>		4 1/8	4 1/8
<b>200S</b>	4 3/8	4 3/8	
<b>NCDQ8B106-025S</b>	0.27	2 1/8	#6-32UNC-2 1/8
<b>037S</b>		2 1/4	2 1/4
<b>050S</b>		2 3/8	2 3/8
<b>062S</b>		2 1/2	2 1/2
<b>075S</b>		2 5/8	2 5/8
<b>087S</b>		2 3/4	2 3/4
<b>100S</b>		2 7/8	2 7/8
<b>125S</b>		3 3/4	3 3/4
<b>150S</b>		4	4
<b>175S</b>		4 1/4	4 1/4
<b>200S</b>	4 1/2	4 1/2	

Model	C	D	Bolt size
			order number
<b>NCDQ8B150-025S</b>	0.33	2 1/8	#10-24UNC-2 1/8
<b>037S</b>		2 1/4	2 1/4
<b>050S</b>		2 3/8	2 3/8
<b>062S</b>		2 1/2	2 1/2
<b>075S</b>		2 5/8	2 5/8
<b>087S</b>		2 3/4	2 3/4
<b>100S</b>		2 7/8	2 7/8
<b>125S</b>		3 3/4	3 3/4
<b>150S</b>		4	4
<b>175S</b>		4 1/4	4 1/4
<b>200S</b>	4 1/2	4 1/2	
<b>NCDQ8B200-025S</b>	0.39	2 1/4	#10-24UNC-2 1/4
<b>037S</b>		2 3/8	2 3/8
<b>050S</b>		2 1/2	2 1/2
<b>062S</b>		2 5/8	2 5/8
<b>075S</b>		2 3/4	2 3/4
<b>087S</b>		2 7/8	2 7/8
<b>100S</b>		3	3
<b>125S</b>		3 7/8	3 7/8
<b>150S</b>		4 1/8	4 1/8
<b>175S</b>		4 3/8	4 3/8
<b>200S</b>	4 5/8	4 5/8	
<b>NCDQ8B250-025S</b>	0.45	2 1/2	1/4-20UNC-2 1/2
<b>037S</b>		2 5/8	2 5/8
<b>050S</b>		2 3/4	2 3/4
<b>062S</b>		2 7/8	2 7/8
<b>075S</b>		3	3
<b>087S</b>		3 1/8	3 1/8
<b>100S</b>		3 1/4	3 1/4
<b>125S</b>		4 3/8	4 3/8
<b>150S</b>		4 5/8	4 5/8
<b>175S</b>		4 7/8	4 7/8
<b>200S</b>	5 1/8	5 1/8	

## Mounting Bolt Size for NCDQ8BZ056 to 250-□S(With Auto switch), Super compact

Model	C	D	Bolt size
			order number
<b>NCDQ8BZ056-025S</b>	0.19	1 1/2	#4-40UNC-1 1/2
<b>037S</b>		1 5/8	1 5/8
<b>050S</b>		1 3/4	1 3/4
<b>062S</b>		1 7/8	1 7/8
<b>075S</b>		2	2
<b>087S</b>		2 1/8	2 1/8
<b>100S</b>		2 1/4	2 1/4
<b>125S</b>		3 1/8	3 1/8
<b>150S</b>		3 3/8	3 3/8
<b>175S</b>		3 5/8	3 5/8
<b>200S</b>	3 7/8	3 7/8	
<b>NCDQ8BZ075-025S</b>	0.21	1 1/2	#6-32UNC-1 1/2
<b>037S</b>		1 5/8	1 5/8
<b>050S</b>		1 3/4	1 3/4
<b>062S</b>		1 7/8	1 7/8
<b>075S</b>		2	2
<b>087S</b>		2 1/8	2 1/8
<b>100S</b>		2 1/4	2 1/4
<b>125S</b>		3 1/8	3 1/8
<b>150S</b>		3 3/8	3 3/8
<b>175S</b>		3 5/8	3 5/8
<b>200S</b>	3 7/8	3 7/8	
<b>NCDQ8BZ106-025S</b>	0.27	1 5/8	#6-32UNC-1 5/8
<b>037S</b>		1 3/4	1 3/4
<b>050S</b>		1 7/8	1 7/8
<b>062S</b>		2	2
<b>075S</b>		2 1/8	2 1/8
<b>087S</b>		2 1/4	2 1/4
<b>100S</b>		2 3/8	2 3/8
<b>125S</b>		3 1/4	3 1/4
<b>150S</b>		3 1/2	3 1/2
<b>175S</b>		3 3/4	3 3/4
<b>200S</b>	4	4	

Model	C	D	Bolt size
			order number
<b>NCDQ8BZ150-025S</b>	0.33	1 5/8	#10-24UNC-1 5/8
<b>037S</b>		1 3/4	1 3/4
<b>050S</b>		1 7/8	1 7/8
<b>062S</b>		2	2
<b>075S</b>		2 1/8	2 1/8
<b>087S</b>		2 1/4	2 1/4
<b>100S</b>		2 3/8	2 3/8
<b>125S</b>		3 1/4	3 1/4
<b>150S</b>		3 1/2	3 1/2
<b>175S</b>		3 3/4	3 3/4
<b>200S</b>	4	4	
<b>NCDQ8BZ200-025S</b>	0.39	1 5/8	#10-24UNC-1 5/8
<b>037S</b>		1 3/4	1 3/4
<b>050S</b>		1 7/8	1 7/8
<b>062S</b>		2	2
<b>075S</b>		2 1/8	2 1/8
<b>087S</b>		2 1/4	2 1/4
<b>100S</b>		2 3/8	2 3/8
<b>125S</b>		2 5/8	2 5/8
<b>150S</b>		2 7/8	2 7/8
<b>175S</b>		3 1/8	3 1/8
<b>200S</b>	3 3/8	3 3/8	
<b>NCDQ8BZ250-025S</b>	0.45	1 7/8	1/4-20UNC-1 7/8
<b>037S</b>		2	2
<b>050S</b>		2 1/8	2 1/8
<b>062S</b>		2 1/4	2 1/4
<b>075S</b>		2 3/8	2 3/8
<b>087S</b>		2 1/2	2 1/2
<b>100S</b>		2 5/8	2 5/8
<b>125S</b>		3 3/4	3 3/4
<b>150S</b>		4	4
<b>175S</b>		4 1/4	4 1/4
<b>200S</b>	4 1/2	4 1/2	

# Series NCQ8

## Mounting Bolt

Mounting method: Mounting bolt for through-hole style of NCQ8B is available as an option.

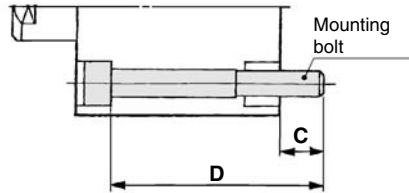

## Mounting Bolt Size for NCQ8B056 to 250-□T(Without Auto switch)

Model	C	D	Bolt size		
				order number	
NCQ8B056-012T	0.19	1 1/4	#4-40UNC-1 1/4		
025T		1 3/8	1 3/8		
037T		1 1/2	1 1/2		
050T		1 5/8	1 5/8		
062T		1 3/4	1 3/4		
075T		1 7/8	1 7/8		
087T		2	2		
100T		2 1/8	2 1/8		
125T		3	3		
150T		3 1/4	3 1/4		
175T	0.25	3 1/2	3 1/2		
200T		3 3/4	3 3/4		
NCQ8B075-012T		0.21	1 1/4	#6-32UNC-1 1/4	
025T			1 3/8	1 3/8	
037T	1 1/2		1 1/2		
050T	1 5/8		1 5/8		
062T	1 3/4		1 3/4		
075T	1 7/8		1 7/8		
087T	2		2		
100T	2 1/8		2 1/8		
125T	3		3		
150T	0.27		3 1/4	3 1/4	
175T		3 1/2	3 1/2		
200T		3 3/4	3 3/4		
NCQ8B106-012T		0.27	1 5/8	#6-32UNC-1 5/8	
025T	1 3/4		1 3/4		
037T	1 7/8		1 7/8		
050T	2		2		
062T	2 1/8		2 1/8		
075T	2 1/4		2 1/4		
087T	2 3/8		2 3/8		
100T	2 1/2		2 1/2		
125T	3 3/8		3 3/8		
150T	3 5/8		3 5/8		
175T	3 7/8		3 7/8		
200T	4 1/8		4 1/8		

Model	C	D	Bolt size		
				order number	
NCQ8B150-012T	0.33	1 5/8	#10-24UNC-1 5/8		
025T		1 3/4	1 3/4		
037T		1 7/8	1 7/8		
050T		2	2		
062T		2 1/8	2 1/8		
075T		2 1/4	2 1/4		
087T		2 3/8	2 3/8		
100T		2 1/2	2 1/2		
125T		3 3/8	3 3/8		
150T		3 5/8	3 5/8		
175T	0.39	3 7/8	3 7/8		
200T		4 1/8	4 1/8		
NCQ8B200-012T		0.39	1 3/4	#10-24UNC-1 3/4	
025T			1 7/8	1 7/8	
037T	2		2		
050T	2 1/8		2 1/8		
062T	2 1/4		2 1/4		
075T	2 3/8		2 3/8		
087T	2 1/2		2 1/2		
100T	2 5/8		2 5/8		
125T	3 1/2		3 1/2		
150T	3 3/4		3 3/4		
175T	0.45	4	4		
200T		4 1/4	4 1/4		
NCQ8B250-012T		0.45	2 1/4	1/4-20UNC-2 1/4	
025T			2 3/8	2 3/8	
037T	2 1/2		2 1/2		
050T	2 5/8		2 5/8		
062T	2 3/4		2 3/4		
075T	2 7/8		2 7/8		
087T	3		3		
100T	3 1/8		3 1/8		
125T	4 1/4		4 1/4		
150T	4 1/2		4 1/2		
175T	0.45	4 3/4	4 3/4		
200T		5	5		

# Compact Cylinder Single Acting, Single Rod **Series NCQ8**

## Mounting Bolt Size for NCDQ8B056 to 250-□T(With Auto switch)

Model	C	D	Bolt size
			order number
NCDQ8B056-025T	0.18	1 3/4	#4-40UNC-1 3/4
037T		1 7/8	1 7/8
050T		2	2
062T		2 1/8	2 1/8
075T		2 1/4	2 1/4
087T		2 3/8	2 3/8
100T		2 1/2	2 1/2
125T		3 3/8	3 3/8
150T		3 5/8	3 5/8
175T		3 7/8	3 7/8
200T	4 1/8	4 1/8	
NCDQ8B075-025T	0.21	2 1/4	#6-32UNC-2 1/4
037T		2 3/8	2 3/8
050T		2 1/2	2 1/2
062T		2 5/8	2 5/8
075T		2 3/4	2 3/4
087T		2 7/8	2 7/8
100T		3	3
125T		3 7/8	3 7/8
150T		4 1/8	4 1/8
175T		4 3/8	4 3/8
200T	4 5/8	4 5/8	
NCDQ8B106-025T	0.27	2 5/8	#6-32UNC-2 5/8
037T		2 3/4	2 3/4
050T		2 7/8	2 7/8
062T		3	3
075T		3 1/8	3 1/8
087T		3 1/4	3 1/4
100T		3 3/8	3 3/8
125T		4 1/4	4 1/4
150T		4 1/2	4 1/2
175T		4 3/4	4 3/4
200T	5	5	

Model	C	D	Bolt size
			order number
NCDQ8B150-025T	0.33	2 5/8	#10-24UNC-2 5/8
037T		2 3/4	2 3/4
050T		2 7/8	2 7/8
062T		3	3
075T		3 1/8	3 1/8
087T		3 1/4	3 1/4
100T		3 3/8	3 3/8
125T		4 1/4	4 1/4
150T		4 1/2	4 1/2
175T		4 3/4	4 3/4
200T	5	5	
NCDQ8B200-025T	0.39	2 3/4	#10-24UNC-2 3/4
037T		2 7/8	2 7/8
050T		3	3
062T		3 1/8	3 1/8
075T		3 1/4	3 1/4
087T		3 3/8	3 3/8
100T		3 1/2	3 1/2
125T		4 3/8	4 3/8
150T		4 5/8	4 5/8
175T		4 7/8	4 7/8
200T	5 1/8	5 1/8	
NCDQ8B250-025T	0.45	3 1/4	1/4-20UNC-3 1/4
037T		3 3/8	3 3/8
050T		3 1/2	3 1/2
062T		3 5/8	3 5/8
075T		3 3/4	3 3/4
087T		3 7/8	3 7/8
100T		4	4
125T		5 1/8	5 1/8
150T		5 3/8	5 3/8
175T		5 5/8	5 5/8
200T	5 7/8	5 7/8	

## Mounting Bolt Size for NCDQ8BZ056 to 250-□T(With Auto switch), Super compact

Model	C	D	Bolt size
			order number
NCDQ8BZ056-025T	0.19	1 5/8	#4-40UNC-1 5/8
037T		1 3/4	1 3/4
050T		1 7/8	1 7/8
062T		2	2
075T		2 1/8	2 1/8
087T		2 1/4	2 1/4
100T		2 3/8	2 3/8
125T		3 1/4	3 1/4
150T		3 1/2	3 1/2
175T		3 3/4	3 3/4
200T	4	4	
NCDQ8BZ075-025T	0.21	1 7/8	#6-32UNC-1 7/8
037T		2	2
050T		2 1/8	2 1/8
062T		2 1/4	2 1/4
075T		2 3/8	2 3/8
087T		2 1/2	2 1/2
100T		2 5/8	2 5/8
125T		3 1/2	3 1/2
150T		3 3/4	3 3/4
175T		4	4
200T	4 1/2	4 1/4	
NCDQ8BZ106-025T	0.27	2 1/8	#6-32UNC-2 1/8
037T		2 1/4	2 1/4
050T		2 3/8	2 3/8
062T		2 1/2	2 1/2
075T		2 5/8	2 5/8
087T		2 3/4	2 3/4
100T		2 7/8	2 7/8
125T		3 3/4	3 3/4
150T		4	4
175T		4 1/4	4 1/4
200T	4 1/2	4 1/2	

Model	C	D	Bolt size
			order number
NCDQ8BZ150-025T	0.33	2 1/8	#10-24UNC-2 1/8
037T		2 1/4	2 1/4
050T		2 3/8	2 3/8
062T		2 1/2	2 1/2
075T		2 5/8	2 5/8
087T		2 3/4	2 3/4
100T		2 7/8	2 7/8
125T		3 3/4	3 3/4
150T		4	4
175T		4 1/4	4 1/4
200T	4 1/2	4 1/2	
NCDQ8BZ200-025T	0.39	2 1/8	#10-24UNC-2 1/8
037T		2 1/4	2 1/4
050T		2 3/8	2 3/8
062T		2 1/2	2 1/2
075T		2 5/8	2 5/8
087T		2 3/4	2 3/4
100T		2 7/8	2 7/8
125T		3 3/4	3 3/4
150T		4	4
175T		4 1/4	4 1/4
200T	4 1/2	4 1/2	
NCDQ8BZ250-025T	0.45	2 5/8	1/4-20UNC-2 5/8
037T		2 3/4	2 3/4
050T		2 7/8	2 7/8
062T		3	3
075T		3 1/8	3 1/8
087T		3 1/4	3 1/4
100T		3 3/8	3 3/8
125T		4 1/2	4 1/2
150T		4 3/4	4 3/4
175T		5	5
200T	5 1/4	5 1/4	

# Series NCQ8

## Construction/Single Acting Spring Return

Without auto switch

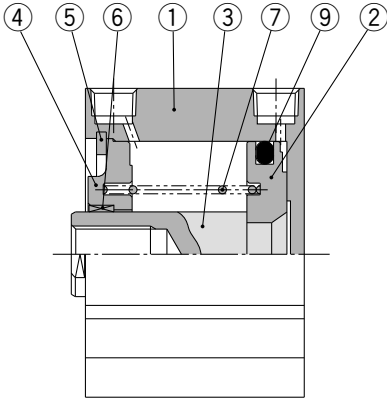

With auto switch

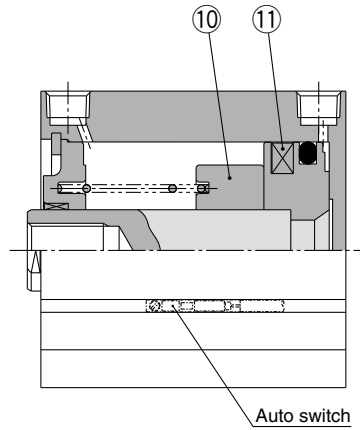

Male thread

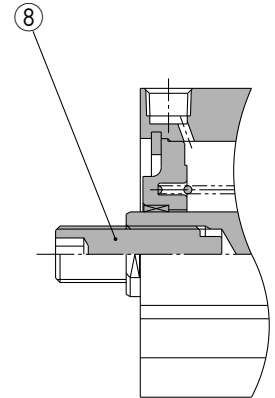

### Parts List

No.	Description	Material	Remarks
1	<b>Cylinder tube</b>	Aluminum alloy	Hard anodized
2	<b>Piston</b>	Aluminum alloy	Chromated
3	<b>Piston rod</b>	Stainless steel	056 to 106
		Carbon steel	150 to 250 Hard chrome plated
4	<b>Collar</b>	Aluminum alloy	056, 075, 106, 200, 250 Anodized
		Stainless steel	150
5	<b>Snap ring</b>	Carbon tool steel	Phosphate coated
6	<b>Bushing</b>	Oil-impregnated sintered alloy	106 only
		Phosphor bronze alloy	150, 200, 250 only
7	<b>Return spring</b>	Piano wire	Zinc chromated
8	<b>Stud</b>	Steel alloy	Electroless nickel plated
9	<b>Piston seal</b>	NBR	
10	<b>Spacer</b>	Aluminum alloy	Chromated, Use for standard type only.
11	<b>Magnet</b>	—	

### Repair Parts: Seal Kit for Single Acting, Spring Return

Bore size	Kit no.	Remarks
056(9/16")	NCQ8B056-S-PS	Piston seal is included.
075(3/4")	NCQ8B075-S-PS	
106(1 1/16")	NCQ8B106-S-PS	
150(1 1/2")	NCQ8B150-S-PS	
200(2")	NCQ8B200-S-PS	
250(2 1/2")	NCQ8B250-S-PS	

## Construction/Single Acting Spring Extend

**Without auto switch**

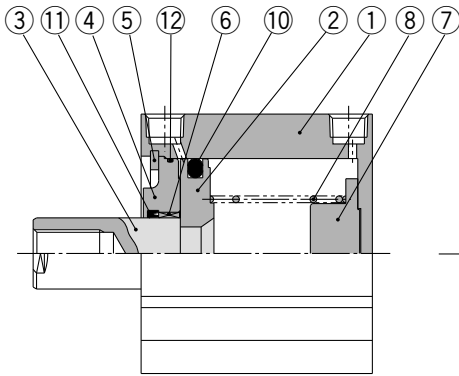

**With auto switch**

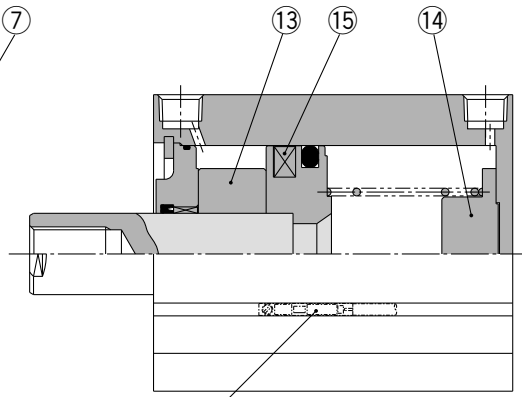

**Male thread**

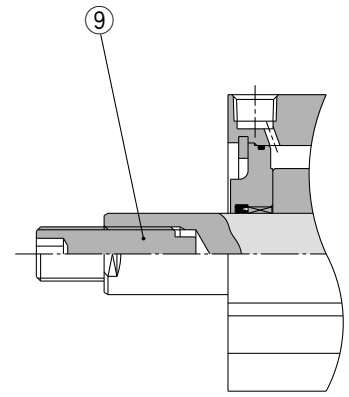

**Parts List**

No.	Description	Material	Remarks
1	<b>Cylinder tube</b>	Aluminum alloy	Hard anodized
2	<b>Piston</b>	Aluminum alloy	Chromated
3	<b>Piston rod</b>	Stainless steel	056 to 106
		Carbon steel	150 to 250 Hard chrome plated
4	<b>Collar</b>	Aluminum alloy	Anodized
5	<b>Snap ring</b>	Carbon tool steel	Phosphate coated
6	<b>Bushing</b>	Phosphor bronze alloy	200, 250 only
7	<b>Spacer</b>	Aluminum alloy	Chromated
8	<b>Return spring</b>	Piano wire	Zinc chromated
9	<b>Stud</b>	Steelalloy	Electroless nickel plated
10	<b>Piston seal</b>	NBR	
11	<b>Rod seal</b>	NBR	
12	<b>Tube gasket</b>	NBR	
13	<b>Spacer</b>	Aluminum alloy	Chromated, Use for standard type only
14	<b>Spacer A</b>	Aluminum alloy	Chromated
15	<b>Magnet</b>	—	

**Repair Parts: Seal Kit for Single Acting Spring Extend**

Bore size	Kit no.	Remarks
<b>056(9/16")</b>	NCQ8B056-T-PS	Piston seal, rod seal and, tube gasket are included.
<b>075(3/4")</b>	NCQ8B075-T-PS	
<b>106(1 1/16")</b>	NCQ8B106-T-PS	
<b>150(1 1/2")</b>	NCQ8B150-T-PS	
<b>200(2")</b>	NCQ8B200-T-PS	
<b>250(2 1/2")</b>	NCQ8B250-T-PS	

# Series NCQ8

## Dimensions/NCQ8B056 to 250-□S [Without Auto switch]

### 056(9/16")

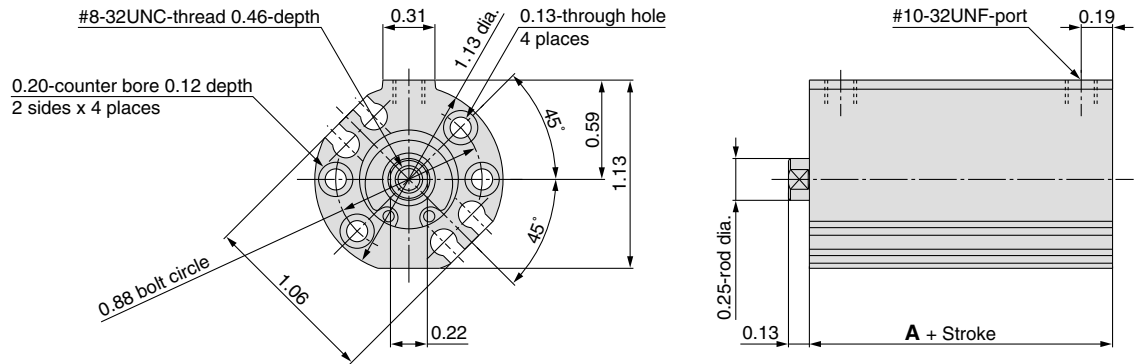

Symbol	A
Stroke	
1/8" to 1"	0.81
1 1/4" to 2"	1.38

### 075(3/4"), 106(1 1/16"), 150(1 1/2"), 200(2"), 250(2 1/2")

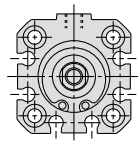

For 075, 106

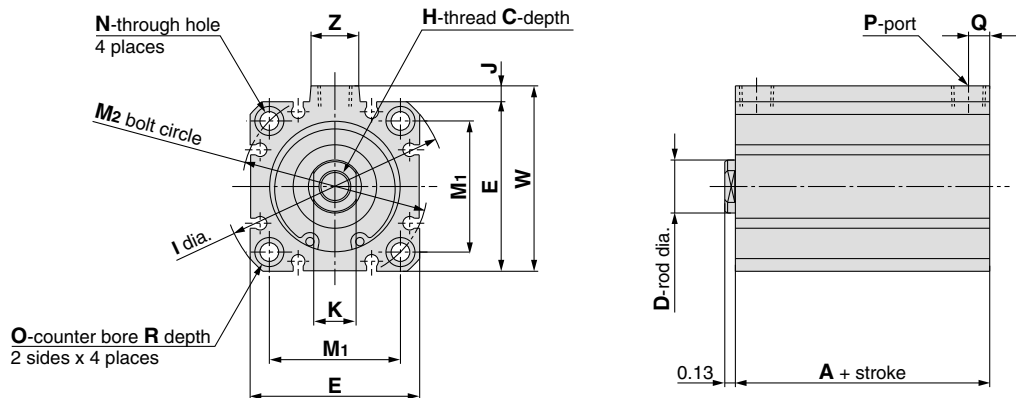

Symbol	A		C		D	E	H	I	J	K	M <sub>1</sub>	M <sub>2</sub>	N	O	P	Q	R	W	Z
	1/8" to 1"st	1 1/4" to 2"st	1/8" to 1/4"st	3/8" to 2"st															
<b>075(3/4")</b>	0.81	1.38	0.46		0.31	1.25	#10-32UNF	1.56	0.06	0.25	0.86	1.22	0.15	0.25	#10-32UNF	0.19	0.15	1.31	0.38
<b>106(1 1/16")</b>	0.88	1.50	0.52	0.70	0.50	1.56	5/16-24UNF	2.03	0.16	0.44	1.19	1.69	0.15	0.25	NPT1/8	0.25	0.15	1.72	0.56
<b>150(1 1/2")</b>	0.88	1.50	0.50	0.70	0.63	2.00	3/8-24UNF	2.63	0.19	0.50	1.55	2.19	0.22	0.34	NPT1/8	0.25	0.20	2.19	0.56
<b>200(2")</b>	0.94	1.56	0.44	0.70	0.75	2.53	1/2-20UNF	3.13	0.20	0.63	1.90	2.69	0.22	0.34	NPT1/8	0.25	0.20	2.73	0.56
<b>250(2 1/2")</b>	1.19	2.06	0.44	0.70	0.75	2.84	1/2-20UNF	3.75	0.39	0.63	2.30	3.25	0.28	0.41	NPT1/4	0.33	0.26	3.23	0.69



# Compact Cylinder Single Acting, Single Rod **Series NCQ8**

## Dimensions/NCQ8B(Z)056 to 250-□S [With Auto switch (Super compact)]

### 056(9/16")

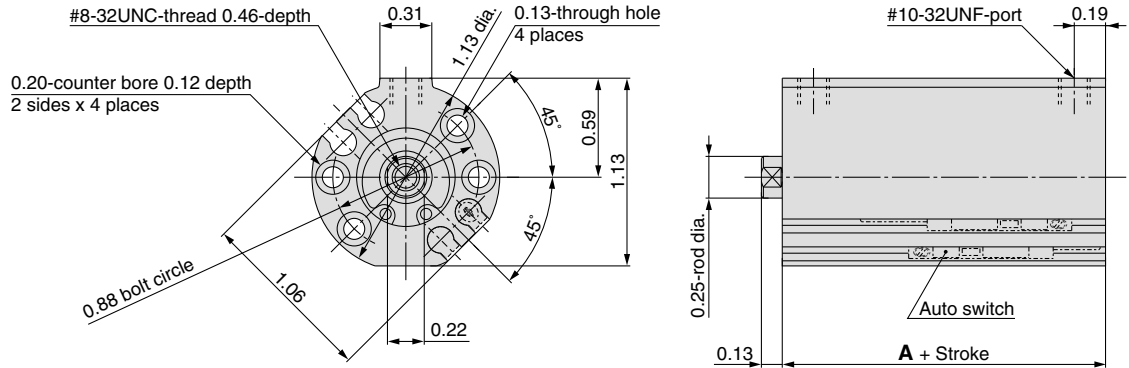

Symbol	A
Stroke	
1/4" to 1"	1.44
1 1/4" to 2"	2.00

### 075(3/4"), 106(1 1/16"), 150(1 1/2"), 200(2"), 250(2 1/2")

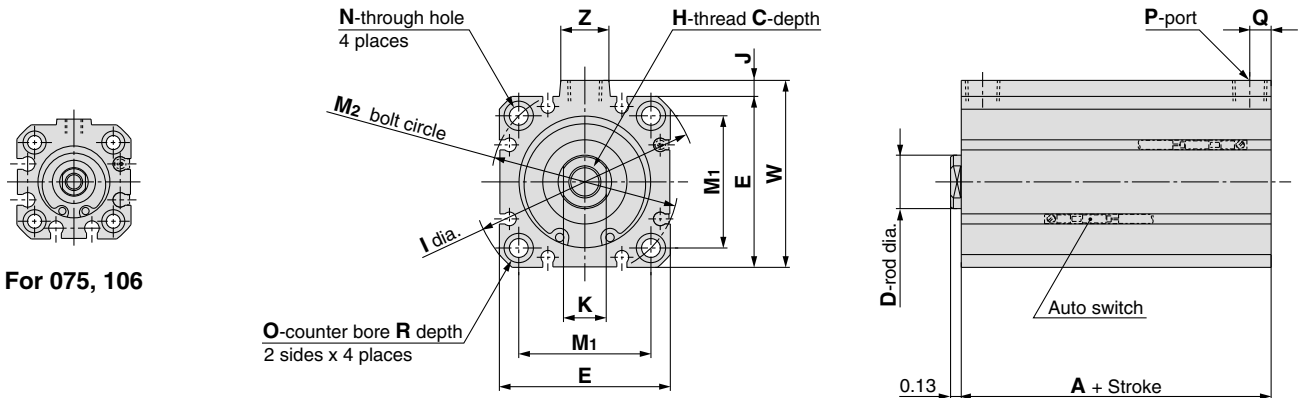

For 075, 106

Symbol	A				C		D	E	H	I	J	K	M1	M2	N	O	P	Q	R	W	Z	
	Standard	Super compact	Standard	Super compact																		
Bore	1/8"to1"st	1 1/4"to2"st	1/4"to1"st	1 1/4"to2"st	Standard	Super compact																
						1/4"st	3/8"to2"st															
<b>075(3/4")</b>	1.69	2.25	1.19	1.75	0.46	0.46	0.31	1.25	#10-32UNF	1.56	0.06	0.25	0.86	1.22	0.15	0.25	#10-32UNF	0.19	0.15	1.31	0.38	
<b>106(1 1/16")</b>	1.75	2.38	1.25	1.88	0.70	0.52	0.70	0.50	1.56	5/16-24UNF	2.03	0.16	0.44	1.19	1.69	0.15	0.25	NPT1/8	0.25	0.15	1.72	0.56
<b>150(1 1/2")</b>	1.75	2.38	1.25	1.88	0.70	0.50	0.70	0.63	2.00	3/8-24UNF	2.63	0.19	0.50	1.55	2.19	0.22	0.34	NPT1/8	0.25	0.20	2.19	0.56
<b>200(2")</b>	1.81	2.44	1.19	1.81	0.70	0.70	0.75	2.53	1/2-20UNF	3.13	0.20	0.63	1.90	2.69	0.22	0.34	NPT1/8	0.25	0.20	2.73	0.56	
<b>250(2 1/2")</b>	2.06	2.94	1.44	2.31	0.70	0.70	0.75	2.84	1/2-20UNF	3.75	0.39	0.63	2.30	3.25	0.28	0.41	NPT1/4	0.33	0.26	3.23	0.69	

# Series NCQ8

## Dimensions/NCQ8B056 to 250-□T [Without Auto switch]

### 056(9/16")

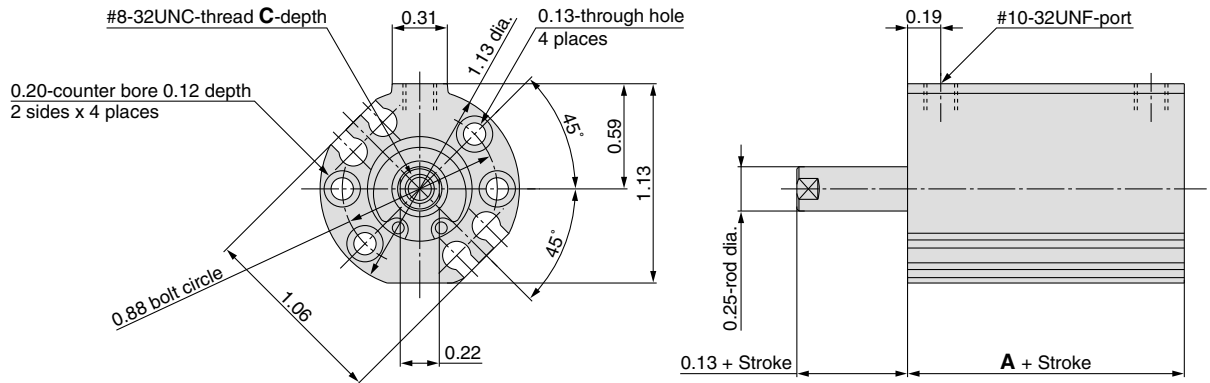

Symbol	A
Stroke	
1/8" to 1"	1.06
1 1/4" to 2"	1.63

Symbol	C
Stroke	
1/8"	0.36
1/4" to 2"	0.46

### 075(3/4"), 106(1 1/16"), 150(1 1/2"), 200(2"), 250(2 1/2")

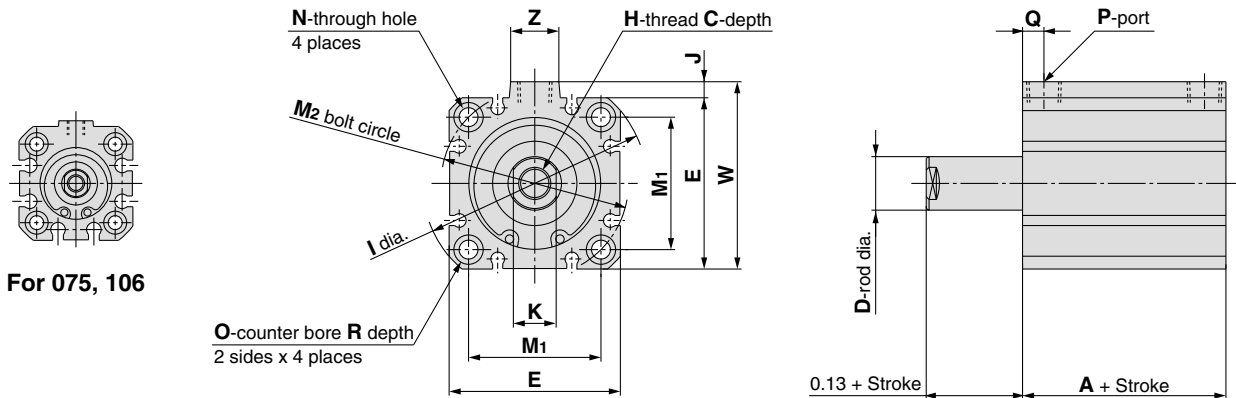

For 075, 106

Symbol	A		C			D	E	H	I	J	K	M <sub>1</sub>	M <sub>2</sub>	N	O	P	Q	R	W	Z
	1/8" to 1"st	1 1/4" to 2"st	1/8"st	1/4"st	3/8" to 2"st															
<b>075(3/4")</b>	1.06	1.63	0.36	0.46	0.31	1.25	#10-32UNF	1.56	0.06	0.25	0.86	1.22	0.15	0.25	#10-32UNF	0.19	0.15	1.31	0.38	
<b>106(1 1/16")</b>	1.38	2.00	0.52	0.70	0.50	1.56	5/16-24UNF	2.03	0.16	0.44	1.19	1.69	0.15	0.25	NPT1/8	0.25	0.15	1.72	0.56	
<b>150(1 1/2")</b>	1.38	2.00	0.50	0.70	0.63	2.00	3/8-24UNF	2.63	0.19	0.50	1.55	2.19	0.22	0.34	NPT1/8	0.25	0.20	2.19	0.56	
<b>200(2")</b>	1.44	2.06	0.44	0.70	0.75	2.53	1/2-20UNF	3.13	0.20	0.63	1.90	2.69	0.22	0.34	NPT1/8	0.25	0.20	2.73	0.56	
<b>250(2 1/2")</b>	1.94	2.81	0.44	0.70	0.75	2.84	1/2-20UNF	3.75	0.39	0.63	2.30	3.25	0.28	0.41	NPT1/4	0.33	0.26	3.23	0.69	

# Compact Cylinder Single Acting, Single Rod **Series NCQ8**

## Dimensions/NCQ8B(Z)056 to 250-□T [With Auto switch(Super compact)]

### 056(9/16")

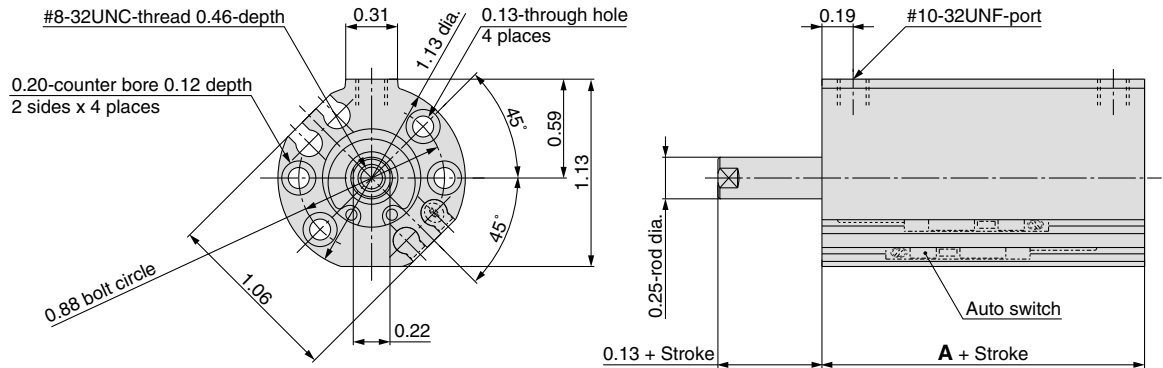

Symbol Stroke	A
1/4" to 1"	1.44
1 1/4" to 2"	2.00

### 075(3/4"), 106(1 1/16"), 150(1 1/2"), 200(2"), 250(2 1/2")

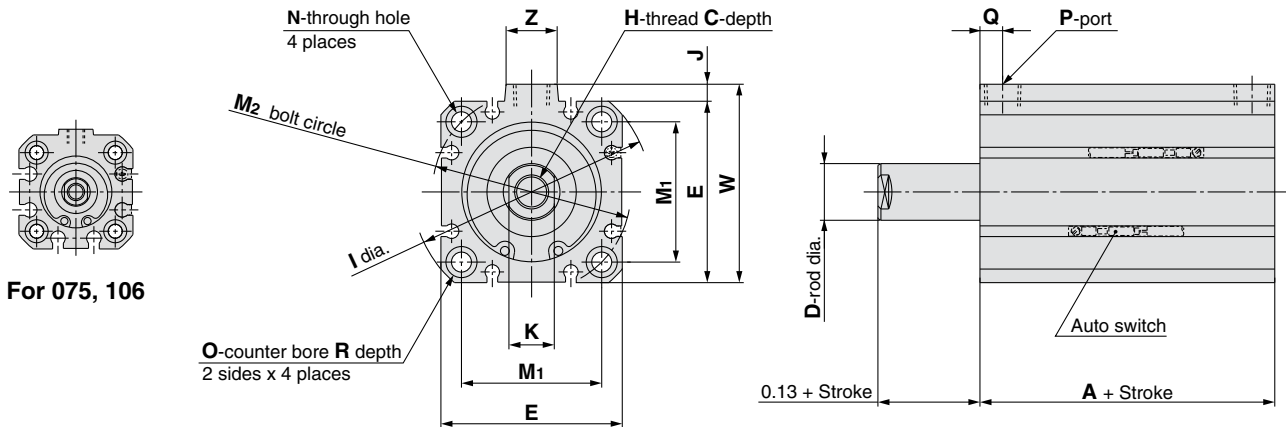

For 075, 106

Symbol	A				C		D	E	H	I	J	K	M <sub>1</sub>	M <sub>2</sub>	N	O	P	Q	R	W	Z	
	Standard	Super compact	Standard	Super compact																		
Bore	1/4"to1"st	1 1/4"to2"st	1/4"to1"st	1 1/4"to2"st	Standard	Super compact																
<b>075(3/4")</b>	1.94	2.50	1.56	2.13	0.46	0.46	0.31	1.25	#10-32UNF	1.56	0.06	0.25	0.86	1.22	0.15	0.25	#10-32UNF	0.19	0.15	1.31	0.38	
<b>106(1 1/16")</b>	2.25	2.88	1.75	2.38	0.70	0.52	0.50	1.56	5/16-24UNF	2.03	0.16	0.44	1.19	1.69	0.15	0.25	NPT1/8	0.25	0.15	1.72	0.56	
<b>150(1 1/2")</b>	2.25	2.88	1.75	2.38	0.70	0.50	0.70	2.00	3/8-24UNF	2.63	0.19	0.50	1.55	2.19	0.22	0.34	NPT1/8	0.25	0.20	2.19	0.56	
<b>200(2")</b>	2.31	2.94	1.69	2.31	0.70	0.70	0.75	2.53	1/2-20UNF	3.13	0.20	0.63	1.90	2.69	0.22	0.34	NPT1/8	0.25	0.20	2.73	0.56	
<b>250(2 1/2")</b>	2.81	3.69	2.19	3.06	0.70	0.70	0.75	2.84	1/2-20UNF	3.75	0.39	0.63	2.30	3.25	0.28	0.41	NPT1/4	0.33	0.26	3.23	0.69	

# Series NCQ8

## Dimensions/Mounting

### Both ends tapped NC(D)Q8A□□-□<sup>S</sup>(M)

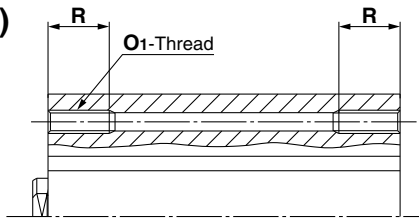

Bore	Symbol	O1	R
056(9/16")	#4-40UNC		0.34
075(3/4")	#6-32UNC		0.34
106(1 1/16")	#6-32UNC		0.50
150(1 1/2")	#10-24UNC		0.50
200(2")	#10-24UNC		0.53
250(2 1/2")	1/4-20UNC		0.65

### Rear clevis/NC(D)Q8C(Z)□-□<sup>S</sup> 056(9/16"), 075(3/4"), 106(1/16"), 150(1 1/2"), 200(2"), 250(2 1/2")

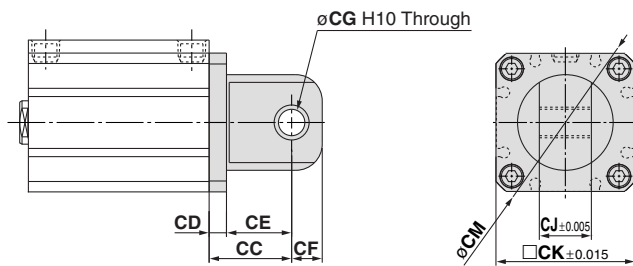

Bore	Symbol	CC	CD	CE	CF	CG	CJ	CK	CM
056(9/16")		0.75	0.19	0.56	0.25	3/16"	0.38	—	1.12
075(3/4")		0.75	0.19	0.56	0.25	3/16"	0.38	0.86	1.56
106(1 1/16")		0.81	0.25	0.56	0.25	3/16"	0.38	1.56	2.03
150(1 1/2")		1.19	0.25	0.94	0.44	3/8	0.75	2.00	2.62
200(2")		1.25	0.31	0.94	0.44	3/8	0.75	2.53	3.13
250(2 1/2")		1.31	0.38	0.93	0.44	3/8	0.75	2.84	3.74

### Screw clearance hole, front mount/ NC(D)Q8E(Z)□-□<sup>S</sup>

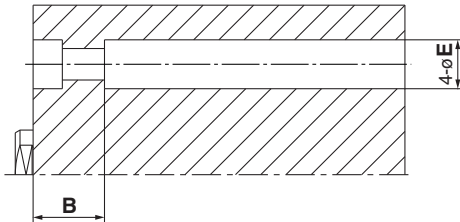

### Screw clearance hole, rear mount/ NC(D)Q8M(Z)□-□<sup>S</sup>

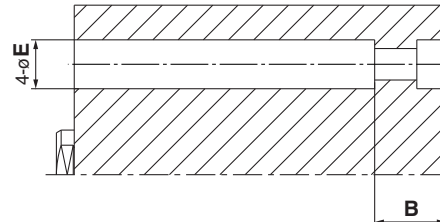

### Screw clearance hole, through/ NC(D)Q8N(Z)□-□<sup>S</sup>

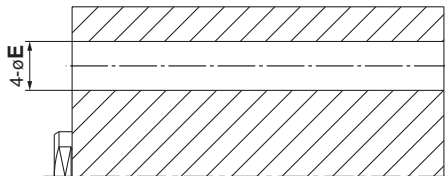

Bore	Symbol	B	E
056(9/16")		0.34	0.20
075(3/4")		0.34	0.25
106(1 1/16")		0.50	0.25
150(1 1/2")		0.50	0.34
200(2")		0.53	0.34
250(2 1/2")		0.66	0.41

## Dimensions/Male rod end

### Male rod end NC(D)Q8□□□-□<sup>S</sup>M

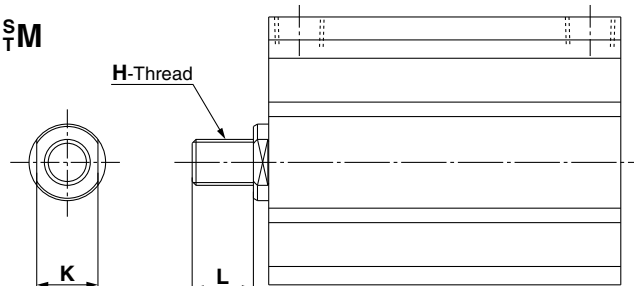

Bore	Symbol	H	L	K
056(9/16")	#8-32UNC		0.38	0.22
075(3/4")	#10-32UNF		0.38	0.25
106(1 1/16")	5/16-24UNF		0.50	0.44
150(1 1/2")	3/8-24UNF		0.50	0.50
200(2")	1/2-20UNF		0.63	0.63
250(2 1/2")	1/2-20UNF		0.63	0.63

# Compact Cylinder Single Acting, Single Rod **Series NCQ8**

## Accessories

### Single Rod Clevis(Rod eye)

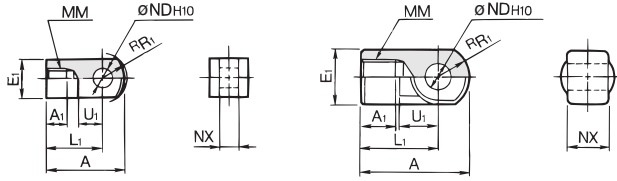

RCS-015  
Material: Carbon steel

RCS-03  
Material: Cast iron

inch

Part no.	Applicable bore size	A	A <sub>1</sub>	E <sub>1</sub>	L <sub>1</sub>	MM	<sup>R</sup> R <sub>1</sub>	U <sub>1</sub>	ND <sub>H10</sub>	NX
RCS-015	056(9/16")	1.26	0.24	0.47	0.98	#8-32UNC	0.47	0.55	3/16 <sup>+0.002</sup> <sub>-0.012</sub>	0.25 <sup>+0.004</sup> <sub>-0.012</sub>
RCS-02	075(3/4")	1.34	0.24	0.63	0.98	#10-32UNF	0.41	0.45	5/16 <sup>+0.002</sup> <sub>-0.008</sub>	0.31 <sup>+0.008</sup> <sub>-0.018</sub>
RCS-03	106(1 1/16")	1.65	0.63	0.87	1.18	5/16-24UNF	0.47	0.55	3/8 <sup>+0.002</sup> <sub>-0.026</sub>	0.71 <sup>+0.012</sup> <sub>-0.026</sub>
RCS-04	150(1 1/2")	1.65	0.63	0.87	1.18	3/8-24UNF	0.47	0.55	3/8 <sup>+0.002</sup> <sub>-0.026</sub>	0.71 <sup>+0.012</sup> <sub>-0.026</sub>
RCS-05	200(2"), 250(2 1/2")	2.20	0.71	1.10	1.57	1/2-20UNF	0.63	0.79	1/2 <sup>+0.002</sup> <sub>-0.026</sub>	0.87 <sup>+0.012</sup> <sub>-0.026</sub>
RCS-08	300(3")	2.80	0.82	1.50	1.97	5/8-18UNF	0.83	1.06	3/4 <sup>+0.002</sup> <sub>-0.026</sub>	1.10 <sup>+0.012</sup> <sub>-0.026</sub>
RCS-10	400(4")	3.11	0.82	1.73	2.17	3/4-16UNF	0.94	1.22	7/8 <sup>+0.002</sup> <sub>-0.026</sub>	1.26 <sup>+0.012</sup> <sub>-0.026</sub>

### Double Rod Clevis(Rod eye)

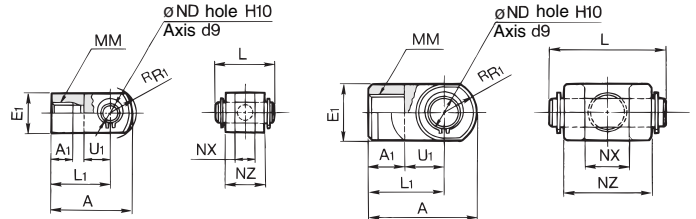

RCD-015  
Material: Carbon steel

RCD-03  
Material: Cast iron

inch

Part no.	Applicable bore size	A	A <sub>1</sub>	E <sub>1</sub>	L <sub>1</sub>	MM	<sup>R</sup> R <sub>1</sub>	U <sub>1</sub>	ND <sub>H10</sub>	NX	NZ	L
RCD-015	056(9/16")	1.10	0.24	0.47	0.83	#8-32UNC	0.47	0.39	3/16 <sup>+0.002</sup> <sub>-0.008</sub>	0.26 <sup>+0.008</sup> <sub>-0.018</sub>	0.47	0.63
RCD-02	075(3/4")	1.34	0.24	0.63	0.98	#10-32UNF	0.41	0.45	5/16 <sup>+0.002</sup> <sub>-0.008</sub>	0.31 <sup>+0.008</sup> <sub>-0.018</sub>	0.63	0.83
RCD-03	106(1 1/16")	1.65	0.63	0.87	1.18	5/16-24UNF	0.47	0.55	3/8 <sup>+0.002</sup> <sub>-0.026</sub>	0.71 <sup>+0.012</sup> <sub>-0.026</sub>	1.42	1.61
RCD-04	150(1 1/2")	1.65	0.63	0.87	1.18	3/8-24UNF	0.47	0.55	3/8 <sup>+0.002</sup> <sub>-0.026</sub>	0.71 <sup>+0.012</sup> <sub>-0.026</sub>	1.42	1.61
RCD-05	200(2"), 250(2 1/2")	2.20	0.79	1.10	1.57	1/2-20UNF	0.63	0.79	1/2 <sup>+0.002</sup> <sub>-0.026</sub>	0.87 <sup>+0.012</sup> <sub>-0.026</sub>	1.73	1.97
RCD-08	300(3")	2.80	0.91	1.50	1.97	5/8-18UNF	0.83	1.06	3/4 <sup>+0.002</sup> <sub>-0.026</sub>	1.10 <sup>+0.012</sup> <sub>-0.026</sub>	2.20	2.52
RCD-10	400(4")	3.11	0.95	1.73	2.17	3/4-16UNF	0.94	1.22	7/8 <sup>+0.002</sup> <sub>-0.026</sub>	1.26 <sup>+0.012</sup> <sub>-0.026</sub>	2.52	2.83

\* Clevis Pin and Snap rings not Included.

### Double Rod Clevis Pin

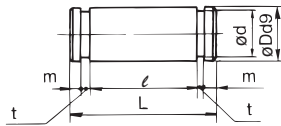

Material: Carbon steel  
inch

Part no.	Applicable bore size	Dd9	L	d	ℓ	m	t
PS-015	056(9/16")	3/16 <sup>-0.000</sup> <sub>-0.000</sub>	0.63	0.175	0.48	0.057	0.018
PS-02	075(3/4")	5/16 <sup>-0.000</sup> <sub>-0.000</sub>	0.827	0.29	0.64	0.065	0.029
PS-03	106(1 1/16"), 150(1 1/2")	3/8 <sup>-0.000</sup> <sub>-0.000</sub>	1.614	0.352	1.43	0.065	0.029
PS-05	200(2"), 250(2 1/2")	1/2 <sup>-0.000</sup> <sub>-0.000</sub>	1.969	0.468	1.74	0.075	0.039
PS-08	300(3")	3/4	2.52	0.70	2.21	0.102	0.046
PS-10	400(4")	7/8	2.83	0.82	2.53	0.102	0.046

### Jam Nut

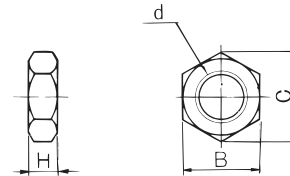

Material: Carbon steel  
inch

Part no.	Applicable bore size	d	H	B	C
JM-01	056(9/16")	#8-32UNC	0.13	0.34	0.39
JM-02	075(3/4")	#10-32UNF	0.13	0.37	0.43
JM-03	106(1 1/16")	5/16-24UNF	0.19	0.50	0.58
JM-04	150(1 1/2")	3/8-24UNF	0.22	0.56	0.65
JM-05	200(2"), 250(2 1/2")	1/2-20UNF	0.31	0.75	0.87
JM-08	300(3")	5/8-18UNF	0.39	0.94	1.08
JM-10	400(4")	3/4-16UNF	0.45	1.13	1.30

## Kits

### Single Rod Clevis(Rod eye)

Kit no.	Applicable bore size	Including		
		Clevis (1)	Pin (1)	Snap rings (2)
RCSK-015	056(9/16")	RCS-015	PS-015	PC-01
RCSK-02	075(3/4")	RCS-02	PS-02	PC-02
RCSK-03	106(1 1/16")	RCS-03	PS-03	PC-03
RCSK-04	150(1 1/2")	RCS-04	PS-03	PC-03
RCSK-05	200(2"), 250(2 1/2")	RCS-05	PS-05	PC-05
RCSK-08	300(3")	RCS-08	PS-08	PC-08
RCSK-10	400(4")	RCS-10	PS-10	PC-10

### Rod Clevis Pin

Kit no.	Applicable bore size	Including	
		Pin (1)	Snap rings (2)
PRA-015	056(9/16")	PS-015	PC-01
PRA-02	075(3/4")	PS-02	PC-02
PRA-03	106(1 1/16"), 150(1 1/2")	PS-03	PC-03
PRA-05	200(2"), 250(2 1/2")	PS-05	PC-05
PRA-08	300(3")	PS-08	PC-08
PRA-10	400(4")	PS-10	PC-10

### Double Rod Clevis(Rod eye)

Kit no.	Applicable bore size	Including		
		Clevis (1)	Pin (1)	Snap rings (2)
RCDK-015	056(9/16")	RCD-015	PS-015	PC-01
RCDK-02	075(3/4")	RCD-02	PS-02	PC-02
RCDK-03	106(1 1/16")	RCD-03	PS-03	PC-03
RCDK-04	150(1 1/2")	RCD-04	PS-03	PC-03
RCDK-05	200(2"), 250(2 1/2")	RCD-05	PS-05	PC-05
RCDK-08	300(3")	RCD-08	PS-08	PC-08
RCDK-10	400(4")	RCD-10	PS-10	PC-10

# Series NCQ8

# Made to Order Specifications

Please contact SMC for detailed dimensions, specifications, and lead times.



## -XC4: With heavy duty scraper

It is suitable for using cylinders under the environment, where there are much dusts in a surrounding area by using a heavy duty scraper on the wiper ring.

### How to Order

Standard model no. **-XC4**

● With heavy duty scraper



Note) The minimum operating pressure is the same as for standard products.

### ⚠ Caution

Other dimensions are the same as NCQ8/standard type.  
Not available for single acting type.

#### Single rod

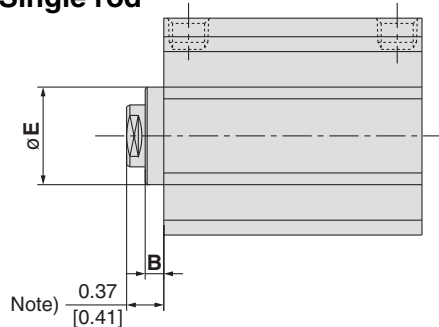

#### Double rod

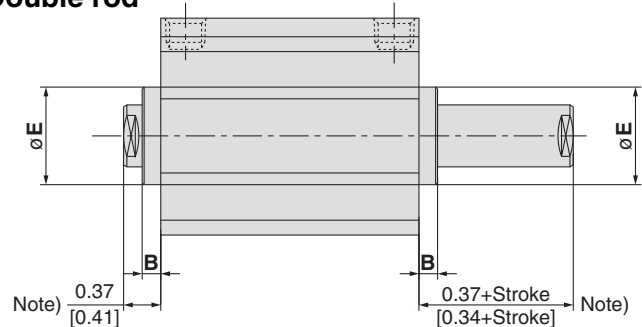

Bore size	B	E
056(9/16")	0.11	0.44
075(3/4")	0.18	0.62
106(1 1/16")	0.17	0.83
150(1 1/2")	0.19	0.98
200(2")	0.19	1.13
250(2 1/2")	0.19	1.13
300(3")	0.19	1.38
400(4")	0.19	1.50

Note) According to the rubber bumper type, its stroke is reduced by 0.06", and the projection of a piston rod is 0.41" [0.34"+Stroke].

## -XB6: Heat resistant (15 to 300°F)

Air cylinder which changed the seal material and grease, so that it could be used even at higher temperature up to 150°C.

### How to Order

Standard model no. **-XB6**

Heat resistant ●

#### Specifications

Ambient temperature range	15 to 300°F (-10 to 150°C)
Seals material	Fluoro rubber
Grease	Heat resistant grease
Additional specifications Dimensions	Same as standard type



- Note 1) Operate without lubrication from a pneumatic system lubricator.
- Note 2) Please contact SMC for details on the maintenance intervals for this cylinder, which differ from those of the standard cylinder.
- Note 3) Built-in magnet type is not available with this option. Please contact SMC, if those combination is needed. High temp., auto switch may be applicable to certain case.
- Note 4) Piston speed is ranged from 2 to 20 in/sec.
- Note 5) With rubber bumper excluded.

### ⚠ Warning

#### Operating Precautions

Be aware that smoking cigarettes, etc. after your hands have come into contact with the grease used in this cylinder can create a gas that is hazardous to humans.

#### Repair Parts: -XB6 Seal Kit

Bore size	Kit no.		Remarks
	NCQ8	NCQ8W	
056(9/16")	NCQ8B056-XB6-PS	NCQ8WB056-XB6-PS	Piston seal, rod seal, and tube gasket are included.
075(3/4")	NCQ8B075-XB6-PS	NCQ8WB075-XB6-PS	
106(1 1/16")	NCQ8B106-XB6-PS	NCQ8WB106-XB6-PS	
150(1 1/2")	NCQ8B150-XB6-PS	NCQ8WB150-XB6-PS	
200(2")	NCQ8B200-XB6-PS	NCQ8WB200-XB6-PS	
250(2 1/2")	NCQ8B250-XB6-PS	NCQ8WB250-XB6-PS	
300(3")	NCQ8B300-XB6-PS	NCQ8WB300-XB6-PS	
400(4")	NCQ8B400-XB6-PS	NCQ8WB400-XB6-PS	

## Auto Switch Mounting

To mount auto switches, follow the instruction illustrated below.

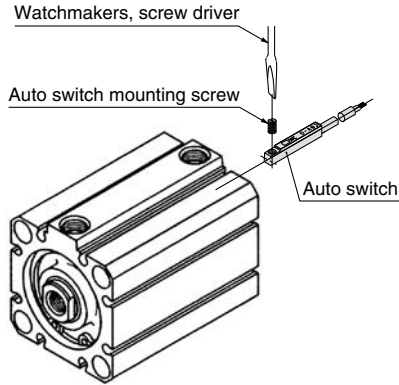

- Use a watchmakers, screwdriver with a handle 0.2" to 0.24"(5 to 6 mm) in diameter when tightening the auto switch mounting screw. Tightening torque should be set 0.08 to 0.15 ft lbs.

The number of surfaces and grooves where an auto switch can be mounted (as direct mounting).

The number of the surfaces and grooves where the auto switch can be mounted, by switch type, are shown in the table below.

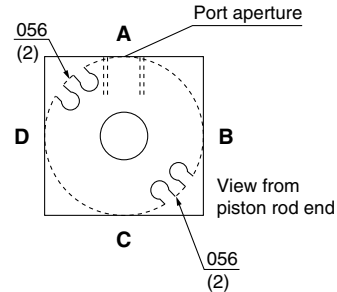

Switch type	D-A9□, M9□, M9□W			
	A (Mounting groove no.)	B (Mounting groove no.)	C (Mounting groove no.)	D (Mounting groove no.)
056(9/16")	Refer to the left.			
075(3/4")	—	○ (2)	○ (2)	○ (2)
106(1 1/16")	—	○ (2)	○ (2)	○ (2)
150(1 1/2")	○ (2)	○ (2)	○ (2)	○ (2)
200(2")	○ (2)	○ (2)	○ (2)	○ (2)
250(2 1/2")	○ (2)	○ (2)	○ (2)	○ (2)
300(3")	○ (2)	○ (2)	○ (2)	○ (2)
400(4")	○ (2)	○ (2)	○ (2)	○ (2)

## Operating Range

Auto switch model	Bore size (in)							
	056	075	106	150	200	250	300	400
D-A9□(V)	0.30	0.30	0.35	0.35	0.35	0.41	0.52	0.46
D-M9□(V)	0.08	0.09	0.10	0.12	0.14	0.12	0.21	0.19
D-M9□W(V)	0.18	0.20	0.26	0.26	0.31	0.35	0.43	0.37
D-F9BAL	0.10	0.12	0.16	0.17	0.19	0.19	0.21	0.19

\* The operating ranges are provided as guidelines including hystereses and are not guaranteed values (assuming approximately ±30% variations). They may vary significantly with ambient environments.

## Minimum Auto Switch Mounting Stroke

Model	No. of auto switches	D-A9□	D-A9□V	D-M9□, D-M9□W	D-M9□V, D-M9□WV	D-F9BAL
NCDQ8A(B)□-□(C)(M) NCDQ8A(B)□-□□S(M)	1	0.62(5/8")	0.25(1/4")	0.62(5/8")	0.25(1/4")	1.00(1")
NCDQ8A(B)W□-□(C)(M) NCDQ8A(B)Z□-□(M)	2		0.37(3/8")			
NCDQ8A(B)□-□□T(M)	1	0.37(3/8")	0.25(1/4")	0.37(3/8")	0.25(1/4")	0.87(7/8")
	2		0.37(3/8")			

# Series NCQ8

## Auto Switches/Proper Mounting Positions and Height for Stroke End Detection

In-line  
D-A9□  
D-M9□  
D-M9□W  
056

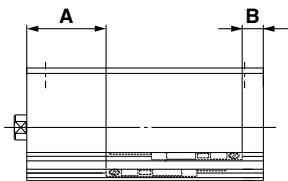

Perpendicular  
D-A9□V  
D-M9□V  
D-M9□WV

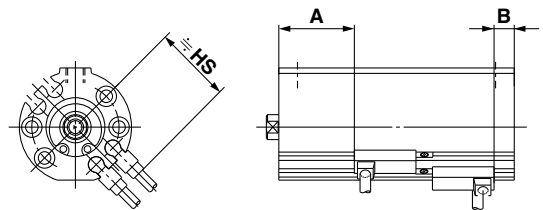

075, 106

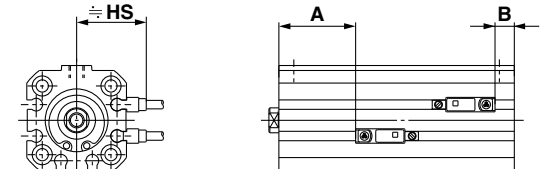
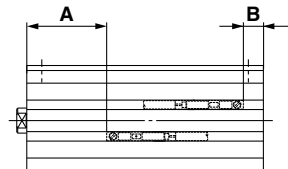

150, 200, 250,  
300, 400

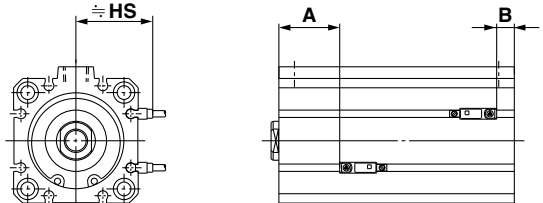
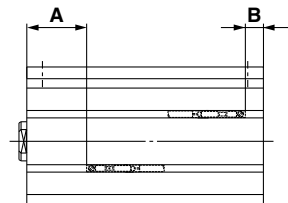

Note) Figures in the table below are references for auto switch mounting positions in the stroke end detection. In an actual setting, confirm the auto switch operating conditions, then adjust it.

**NCDQ8A(B)□-□(C)(M)** (in)

Bore size	D-A9□, D-A9□V			D-M9□(V), D-M9□W(V)			D-F9BAL		
	A	B	HS	A	B	HS	A	B	HS
056	0.61	0.04	0.71	0.77	0.2	0.79	0.73	0.16	0.69
075	0.55	0.08	0.81	0.71	0.24	0.89	0.67	0.2	0.79
106	0.85	0.12	0.96	1	0.28	1.04	0.96	0.24	0.94
150	0.83	0.12	1.18	0.98	0.28	1.26	0.94	0.24	1.16
200	0.81	0.2	1.45	0.96	0.35	1.52	0.93	0.31	1.43
250	0.98	0.28	1.6	1.14	0.43	1.68	1.1	0.39	1.58
300	0.96	0.34	1.94	1.12	0.5	2.03	1.08	0.46	1.94
400	1.12	0.53	2.44	1.28	0.69	2.54	1.24	0.65	2.44

**NCDQ8A(B)□-□T(M) (025st to 100st)** (in)

Bore size	D-A9□, D-A9□V			D-M9□(V), D-M9□W(V)			D-F9BAL		
	A	B	HS	A	B	HS	A	B	HS
056	0.24	0.41	0.71	0.39	0.57	0.79	0.35	0.53	0.69
075	0.55	0.59	0.81	0.71	0.75	0.89	0.67	0.71	0.79
106	0.85	0.61	0.96	1	0.77	1.04	0.96	0.73	0.94
150	0.83	0.63	1.18	0.98	0.79	1.26	0.94	0.75	1.16
200	0.81	0.69	1.45	0.96	0.85	1.52	0.93	0.81	1.43
250	0.98	1.02	1.6	1.14	1.18	1.68	1.1	1.14	1.58

**NCDQ8A(B)□-□S(M) (025st to 100st)** (in)

Bore size	D-A9□, D-A9□V			D-M9□(V), D-M9□W(V)			D-F9BAL		
	A	B	HS	A	B	HS	A	B	HS
056	0.59	0.04	0.71	0.75	0.2	0.79	0.71	0.16	0.69
075	0.81	0.08	0.81	0.96	0.24	0.89	0.93	0.2	0.79
106	0.83	0.12	0.96	0.98	0.28	1.04	0.94	0.24	0.94
150	0.83	0.12	1.18	0.98	0.28	1.26	0.94	0.24	1.16
200	0.81	0.2	1.45	0.96	0.35	1.52	0.93	0.31	1.43
250	0.98	0.28	1.6	1.14	0.43	1.68	1.1	0.39	1.58

**NCDQ8A(B)□-□T(M) (125st to 200st)** (in)

Bore size	D-A9□, D-A9□V			D-M9□(V), D-M9□W(V)			D-F9BAL		
	A	B	HS	A	B	HS	A	B	HS
056	0.24	0.98	0.71	0.39	1.14	0.79	0.35	1.1	0.69
075	0.55	1.14	0.81	0.71	1.3	0.89	0.67	1.26	0.79
106	0.85	1.24	0.96	1	1.4	1.04	0.96	1.36	0.94
150	0.83	1.26	1.18	0.98	1.42	1.26	0.94	1.38	1.16
200	0.81	1.32	1.45	0.96	1.48	1.52	0.93	1.44	1.43
250	0.98	1.89	1.6	1.14	2.05	1.68	1.1	2.01	1.58

**NCDQ8A(B)□-□S(M) (125st to 200st)** (in)

Bore size	D-A9□, D-A9□V			D-M9□(V), D-M9□W(V)			D-F9BAL		
	A	B	HS	A	B	HS	A	B	HS
056	1.16	0.04	0.71	1.32	0.2	0.79	1.28	0.16	0.69
075	1.38	0.08	0.81	1.54	0.24	0.89	1.5	0.2	0.79
106	1.46	0.12	0.96	1.61	0.28	1.04	1.57	0.24	0.94
150	1.44	0.12	1.18	1.59	0.28	1.26	1.56	0.24	1.16
200	1.44	0.2	1.45	1.59	0.35	1.52	1.56	0.31	1.43
250	1.85	0.28	1.6	2.01	0.43	1.68	1.97	0.39	1.58

**NCDQ8A(B)W□-□(C)(M)** (in)

Bore size	D-A9□, D-A9□V			D-M9□(V), D-M9□W(V)			D-F9BAL		
	A	B	HS	A	B	HS	A	B	HS
056	0.69	0.1	0.71	0.85	0.26	0.79	0.81	0.22	0.69
075	0.63	0.16	0.81	0.79	0.31	0.89	0.75	0.28	0.79
106	0.51	0.51	0.96	0.67	0.67	1.04	0.63	0.63	0.94
150	0.55	0.55	1.18	0.71	0.71	1.26	0.67	0.67	1.16
200	0.57	0.57	1.45	0.73	0.73	1.52	0.69	0.69	1.43
250	0.69	0.69	1.6	0.85	0.85	1.68	0.81	0.81	1.58
300	0.9	0.57	1.94	1.06	0.73	2.03	1.02	0.69	1.94
400	1.03	0.76	2.44	1.18	0.91	2.54	1.14	0.88	2.44



## Auto Switches/Proper Mounting Positions and Height for Stroke End Detection

**In-line**  
D-A9□  
D-M9□  
D-M9□W  
**056**

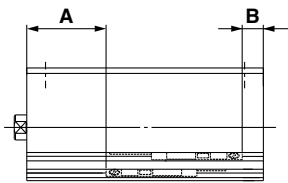

**Perpendicular**  
D-A9□V  
D-M9□V  
D-M9□WV

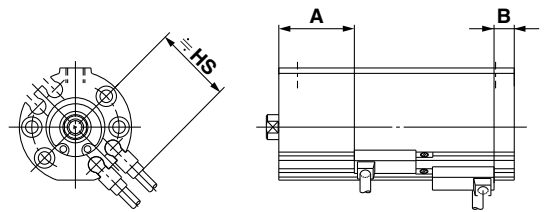

**075, 106**

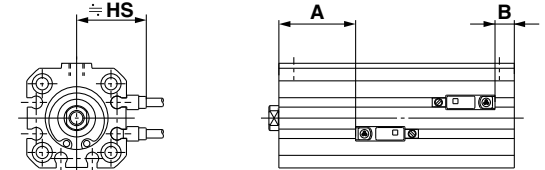
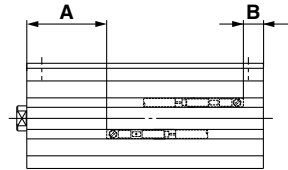

**150, 200, 250  
300, 400**

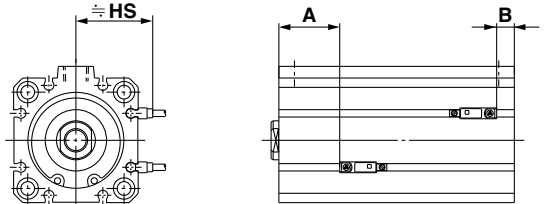
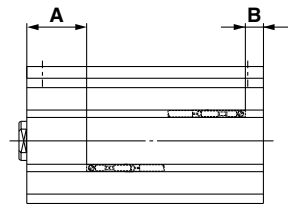

Note) Figures in the table below are references for auto switch mounting positions in the stroke end detection. In an actual setting, confirm the auto switch operating conditions, then adjust it.

**NCDQ8A(B)Z□-□(C)(M)** (in)

Bore size	D-A9□, D-A9□V			D-M9□(V), D-M9□W(V)			D-F9BAL		
	A	B	HS	A	B	HS	A	B	HS
056	0.24	0.04	0.71	0.39	0.2	0.79	0.35	0.16	0.69
075	0.14	0.08	0.81	0.3	0.24	0.89	0.26	0.2	0.79
106	0.33	0.12	0.96	0.49	0.28	1.04	0.45	0.24	0.94
150	0.31	0.12	1.18	0.47	0.28	1.26	0.43	0.24	1.16
200	0.2	0.2	1.45	0.35	0.35	1.52	0.31	0.31	1.43
250	0.35	0.28	1.6	0.51	0.43	1.68	0.47	0.39	1.58
300	0.37	0.34	1.94	0.53	0.5	2.03	0.49	0.46	1.94
400	0.49	0.53	2.44	0.65	0.69	2.54	0.61	0.65	2.44

**NCDQ8A(B)Z□-□T(M) (025st to 100st)** (in)

Bore size	D-A9□, D-A9□V			D-M9□(V), D-M9□W(V)			D-F9BAL		
	A	B	HS	A	B	HS	A	B	HS
056	0.12	0.41	0.71	0.28	0.57	0.79	0.24	0.53	0.69
075	0.18	0.59	0.81	0.33	0.75	0.89	0.3	0.71	0.79
106	0.33	0.61	0.96	0.49	0.77	1.04	0.45	0.73	0.94
150	0.31	0.63	1.18	0.47	0.79	1.26	0.43	0.75	1.16
200	0.2	0.69	1.45	0.35	0.85	1.52	0.31	0.81	1.43
250	0.35	1.02	1.6	0.51	1.18	1.68	0.47	1.14	1.58

**NCDQ8A(B)Z□-□S(M) (025st to 100st)** (in)

Bore size	D-A9□, D-A9□V			D-M9□(V), D-M9□W(V)			D-F9BAL		
	A	B	HS	A	B	HS	A	B	HS
056	0.35	0.04	0.71	0.51	0.2	0.79	0.47	0.16	0.69
075	0.31	0.08	0.81	0.47	0.24	0.89	0.43	0.2	0.79
106	0.33	0.12	0.96	0.49	0.28	1.04	0.45	0.24	0.94
150	0.31	0.12	1.18	0.47	0.28	1.26	0.43	0.24	1.16
200	0.18	0.2	1.45	0.33	0.35	1.52	0.3	0.31	1.43
250	0.35	0.28	1.6	0.51	0.43	1.68	0.47	0.39	1.58

**NCDQ8A(B)Z□-□T(M) (125st to 200st)** (in)

Bore size	D-A9□, D-A9□V			D-M9□(V), D-M9□W(V)			D-F9BAL		
	A	B	HS	A	B	HS	A	B	HS
056	0.12	0.98	0.71	0.28	1.14	0.79	0.24	1.1	0.69
075	0.18	1.14	0.81	0.33	1.3	0.89	0.3	1.26	0.79
106	0.33	1.24	0.96	0.49	1.4	1.04	0.45	1.36	0.94
150	0.31	1.26	1.18	0.47	1.42	1.26	0.43	1.38	1.16
200	0.2	1.32	1.45	0.35	1.48	1.52	0.31	1.44	1.43
250	0.35	1.89	1.6	0.51	2.05	1.68	0.47	2.01	1.58

**NCDQ8A(B)Z□-□S(M) (125st to 200st)** (in)

Bore size	D-A9□, D-A9□V			D-M9□(V), D-M9□W(V)			D-F9BAL		
	A	B	HS	A	B	HS	A	B	HS
056	0.91	0.04	0.71	1.06	0.2	0.79	1.02	0.16	0.69
075	0.87	0.08	0.81	1.02	0.24	0.89	0.98	0.2	0.79
106	0.96	0.12	0.96	1.12	0.28	1.04	1.08	0.24	0.94
150	0.94	0.12	1.18	1.1	0.28	1.26	1.06	0.24	1.16
200	0.81	0.2	1.45	0.96	0.35	1.52	0.93	0.31	1.43
250	1.22	0.28	1.6	1.38	0.43	1.68	1.34	0.39	1.58

# Series NCQ8

# Auto Switch Specifications

## Auto Switch Common Specifications

Type	Reed switches	Solid state switches
Leakage current	None	3-wire: 100 $\mu$ A or less, 2-wire: 0.8 mA or less
Operating time	1.2 ms	1 ms or less
Impact resistance	984 ft/s <sup>2</sup>	3280 ft/s <sup>2</sup>
Insulation resistance	50 M $\Omega$ or more at 500 VDC (between lead wire and case)	
Withstand voltage	1500 VAC for 1 min. (between lead wire and case)	1000 VAC for 1 min. (between lead wire and case)
Ambient temperature	14 to 140°F (-10 to 60°C)	
Enclosure	IEC60529 standard IP67, watertight (JIS C 0920)	
Standard	Conforming to CE Standards	

## Lead Wire Length

### Lead wire length indication

(Example) D-M9BW **L**

#### Lead wire length

Nil	20 in (0.5 m)
M <sup>Note 5)</sup>	39 in (1 m)
L	118 in (3 m)
Z	197 in (5 m)

- Note 1) Lead wire length Z: 197 in applicable auto switches  
 Reed switch: To be dealt with specially  
 Solid state switch: All types are produced upon receipt of order.
- Note 2) The standard lead wire length of solid state switch with timer or with tight water 2-color display is 118" (3 m). (Not available 20" (0.5 m))
- Note 3) For solid state switches with flexible wire specification, add "-61" at the end of the lead wire length.
- Note 4) Robot cable is available as standard for D-M9□(V), D-M9□W(V).
- Note 5) 1m(M): D-M9□W only.
- Note 6) Lead wire tolerance

Lead wire length	Tolerance
20 in (0.5 m)	$\pm 0.59$ in ( $\pm 15$ mm)
39 in (1 m)	$\pm 1.18$ in ( $\pm 30$ mm)
118 in (3 m)	$\pm 3.54$ in ( $\pm 90$ mm)
197 in (5 m)	$\pm 5.91$ in ( $\pm 150$ mm)

(Example) D-F9BAL- **61**

#### Flexible specification

## Auto Switch Hysteresis

Hysteresis is the distance between the position at which piston movement operates an auto switch to the position at which reverse movement turns the switch off. This hysteresis is included in part of the operating range (one side).

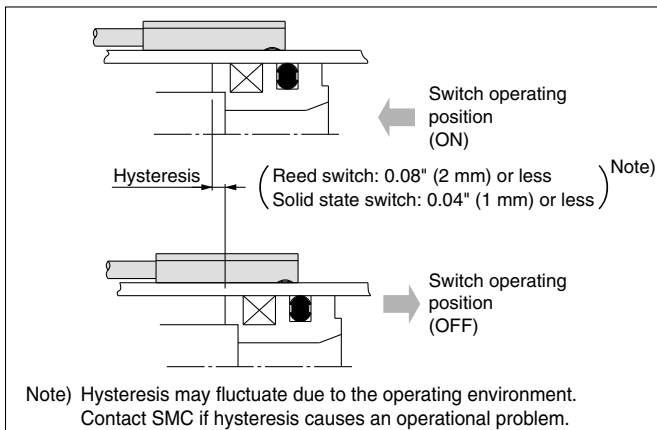

## Contact Protection Box/CD-P11, CD-P12

### Applicable switch type

D-A9 and D-A9□V type switches do not have internal contact protection circuits.

- ① The operated load is an induction load.
- ② The length of wiring to the load is 197" (5 m) or more.
- ③ The load voltage is 100 VAC.

A contact protection box should be used in any of the above situations. The lifetime of the contact may be shortened.

\*There is no need to attach it to solid state auto switches.

### Specifications

Part No.	CD-P11	CD-P12	
Load voltage	100 VAC	200 VAC	24 VDC
Max. load current	25 mA	12.5 mA	50 mA

\* Lead wire length — Switch connection side: 20" (0.5 m)  
 Load connection side: 20" (0.5 m)



### Internal Circuit

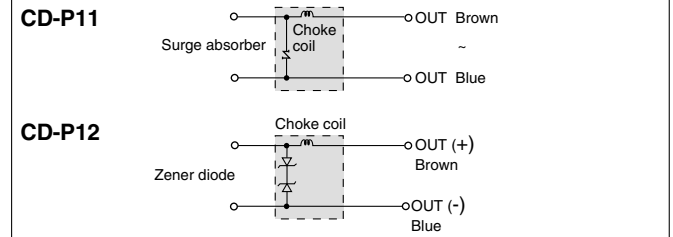

### Dimensions

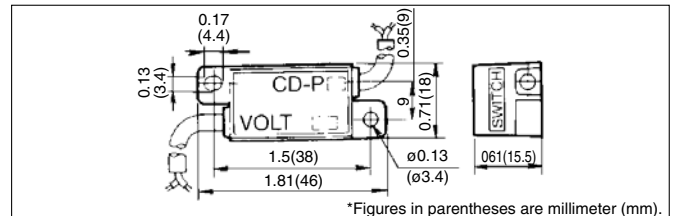

## Contact Protection Box/Connection

To connect a switch unit to a contact protection box, connect the lead wire from the side of the contact protection box marked SWITCH to the lead wire coming out of the switch unit. The switch unit should be kept as close as possible to the contact protection box with a lead wire that is no more than 39.37" (1 m) in length.

# Series NCQ8

# Auto Switch Connections and Examples

## Basic Wiring

Solid state 3-wire, NPN

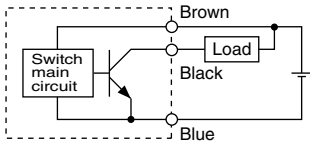

Solid state 3-wire, PNP

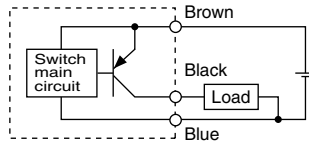

2-wire (Solid state switch)

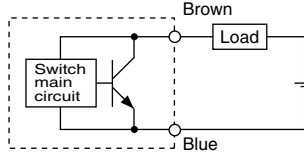

2-wire (Reed switch)

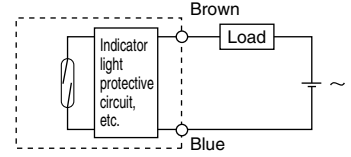

(Power supplies for switch and load are separate)

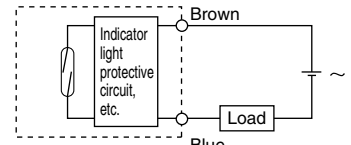
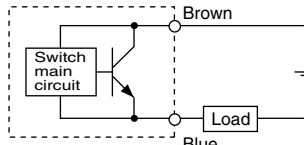
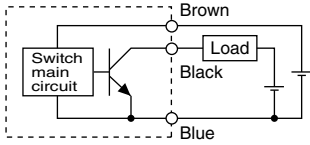

## Examples of Connection to PLC (Programmable Logic Controller)

· Sink input specifications  
3-wire, NPN

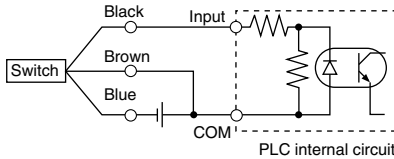

· Source input specifications  
3-wire, PNP

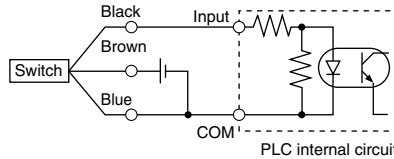

Connect according to the applicable PLC input specifications, as the connection method will vary depending on the PLC input specifications.

2-wire

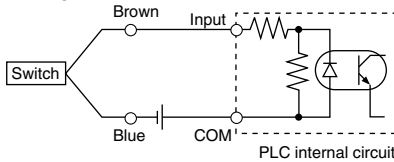

2-wire

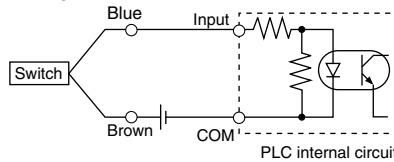

## Connection Examples for AND (Series) and OR (Parallel)

· 3-wire (using relays)

AND connection for NPN output (using relays)

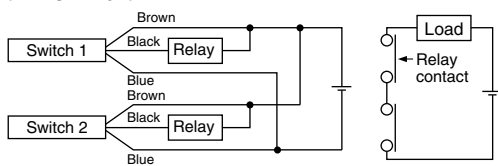

AND connection for NPN output (performed with switches only)

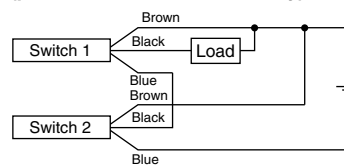

OR connection for NPN output

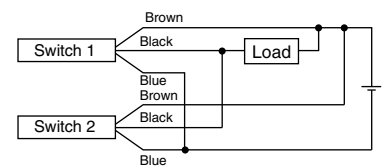

The indicator light illuminates when the two switches are in the ON state.

2-wire with 2-switch AND connection

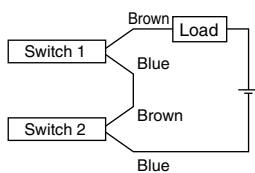

When two switches are connected in series, a load may malfunction because the load voltage will decline when in the ON state. The indicator lights will light when both switches are in the ON state.

Load voltage at ON = Power supply voltage – Internal voltage drop x 2 pcs.  
= 24 V – 4 V x 2 pcs.  
= 16 V

Example: Power supply is 24 VDC  
Internal voltage drop in switch is 4 V.

2-wire with 2-switch OR connection

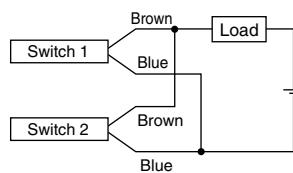

< Solid State >

When two switches are connected in parallel, malfunction may occur because the load voltage will increase when in the OFF state.

Load voltage at OFF = Leakage current x 2 pcs. x Load impedance  
= 1 mA x 2 pcs. x 3 kΩ  
= 6 V

Example: Load impedance is 3 kΩ.  
Leakage current from switch is 1 mA.

< Reed Switch >

Because there is no current leakage, the load voltage will not increase when turned OFF. However, depending on the number of switches in the ON state, the indicator lights may sometimes grow dim or not light up because of the dispersion and reduction of the current flowing to the switches.

# Reed Switch Direct Mounting Style

## D-A90(V)/D-A93(V)/D-A96(V)



### Grommet



### Caution

#### Operating Precautions

- Do not use anything other than the mounting screws attached to the auto switch body to secure the switch. If screws other than those specified are used, it may cause the switch to be damaged.

### Auto Switch Internal Circuit

#### D-A90, A90V

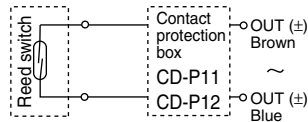

#### D-A93, A93V

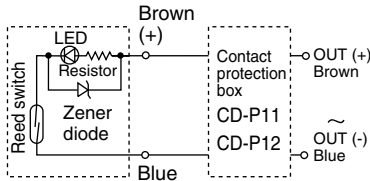

#### D-A96, A96V

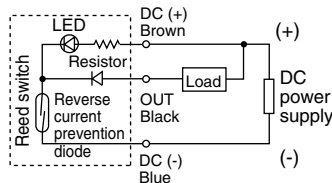

- Note) 1. In the case operation load is an inductive load.  
 2. In the case the wiring length to load is more than 197"(5 m).  
 3. In the case the load voltage is 100 VAC.  
 A contact protection box should be used if any of the above conditions is applicable. The lifetime of the contact may be shortened. (For detailed information about the contact protection box, please refer to page 40.)

### Auto Switch Specification

PLC: Programable Logic Controller

D-A90, D-A90V (Without indicator light)				
Electrical entry direction	D-A90		D-A90V	
	In-line		Perpendicular	
Applicable load	IC circuit, Relay, PLC			
Load voltage	24 V <sub>DC</sub> <sup>AC</sup> or less	48 V <sub>DC</sub> <sup>AC</sup> or less	100 V <sub>DC</sub> <sup>AC</sup> or less	
Maximum load current	50 mA	40 mA	20 mA	
Contact protection circuit	None			
Internal resistance	1 Ω or less (including lead wire length of 118"(3m))			
Standard	Conforming to CE Standards			
D-A93, D-A93V, D-A96, D-A96V (With indicator light)				
Auto switch model	D-A93	D-A93V	D-A96	D-A96V
Electrical entry direction	In-line	Perpendicular	In-line	Perpendicular
Applicable load	Relay, PLC		IC	
Load voltage	24 VDC	100 VAC	4 to 8 VDC	
Load current range and max. load current	5 to 40 mA	5 to 20 mA	20 mA	
Contact protection circuit	None			
Internal voltage drop	D-A93 — 2.4 V or less (to 20 mA)/ 3 V or less (to 40 mA)		D-A93V — 2.7 V or less	
Indicator light	Red LED lights up when ON			
Standard	Conforming to CE Standards			

#### Lead wires

- Oilproof vinyl heavy -duty cord, 0.11" (ø2.7mm), 20" (0.5 m)
- D-A90(V), D-A93(V) 2.8 x 10<sup>-4</sup> in<sup>2</sup> (0.18 mm<sup>2</sup>) x 2 cores (Brown, Blue)
- D-A96(V) 2.3 x 10<sup>-4</sup> in<sup>2</sup> (0.15 mm<sup>2</sup>) x 3 cores (Brown, Black, Blue)

Note 1) Refer to page 40 for auto switch common specifications.

Note 2) Refer to page 40 for lead wire lengths.

Note 3) Visibility of indicator light decreases under 5 mA, and may be hard to recognize under 2.5 mA. For over 1mA, there should be no problem for contact outputs.

### Weight

Unit: OZ, ( ): g

Model	D-A90(V)	D-A93(V)	D-A96(V)
Lead wire length 30 in(0.5 m)	0.21( 6)	0.21( 6)	0.28( 8)
Lead wire length 118 in(3 m)	1.06(30)	1.06(30)	1.45(41)

### Dimensions

Unit: in

#### D-A90, D-A93, D-A96

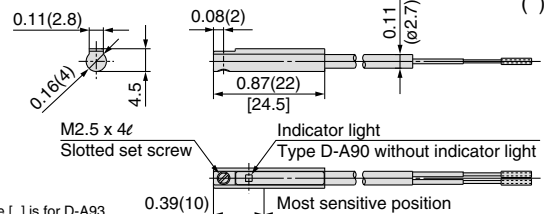

#### D-A90V, D-A93V, D-A96V

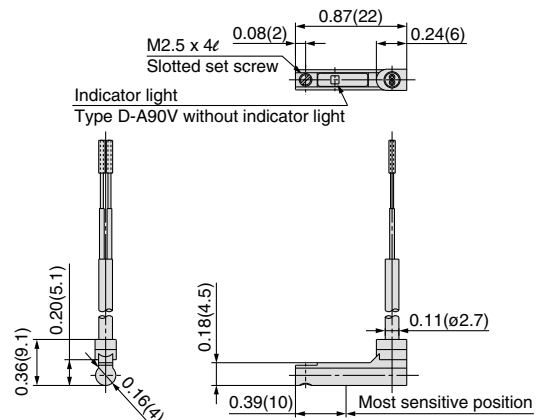

# Solid State Switch Direct Mounting Style

## D-M9N(V)/D-M9P(V)/D-M9B(V)



### Grommet

- 2-wire load current is reduced (2.5 to 40 mA)
- UL certified (style 2844) lead cable is used.
- Flexibility is 1.5 times greater than the conventional model (SMC comparison).
- Using flexible cable as standard spec.



### ⚠ Caution

#### Operating Precautions

Fix the switch with the existing screw installed on the switch body. The switch may be damaged if a screw other than the one supplied, is used.

### Auto Switch Internal Circuit

#### D-M9N, M9NV

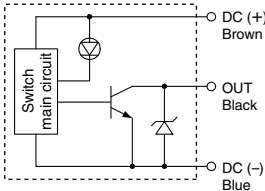

#### D-M9P, M9PV

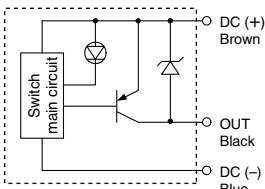

#### D-M9B, M9BV

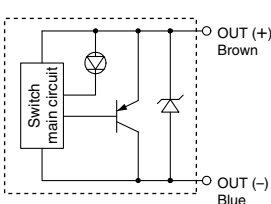

### Auto Switch Specifications

PLC: Abbreviation of Programmable Logic Controller

D-M9□, D-M9□V (With indicator light)						
Auto switch model	D-M9N	D-M9NV	D-M9P	D-M9PV	D-M9B	D-M9BV
Electrical entry direction	In-line	Perpendicular	In-line	Perpendicular	In-line	Perpendicular
Wiring type	3-wire			2-wire		
Output type	NPN		PNP		—	
Applicable load	IC circuit, Relay, PLC				24 VDC relay, PLC	
Power supply voltage	5, 12, 24 VDC (4.5 to 28 V)					—
Current consumption	10 mA or less					—
Load voltage	28 VDC or less		—		24 VDC (10 to 28 VDC)	
Load current	40 mA or less				2.5 to 40 mA	
Internal voltage drop	0.8 V or less					4 V or less
Leakage current	100 μA or less at 24 VDC					0.8 mA or less
Indicator light	Red LED lights when ON.					
Standard	Conforming to CE Standards					

- Lead wires — Oilproof vinyl heavy -duty cord 0.1"(2.7 mm) x 0.13"(3.2mm) ellipse, 2.3 x 10<sup>-4</sup>in<sup>2</sup>(0.15mm<sup>2</sup>), 2 cores: D-M9B(V), 3 cores: D-M9N(V), D-M9P(V)  
Note 1) Refer to page 40 for solid state switch common specifications.  
Note 2) Refer to page 40 for lead wire lengths.

### Weight

Unit: OZ, ( ): g

Auto switch model	D-M9N(V)	D-M9P(V)	D-M9B(V)
Lead wire length in(m)	20(0.5)	0.28( 8)	0.25( 7)
	118(3 )	1.45(41)	1.34(38)
	197(5 )	2.40(68)	2.22(63)

### Dimensions

Unit: in

#### D-M9□

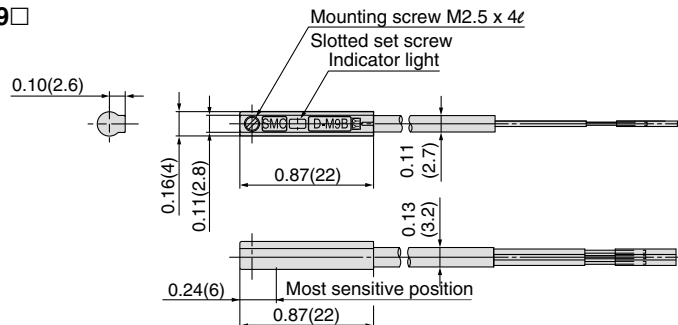

#### D-M9□V

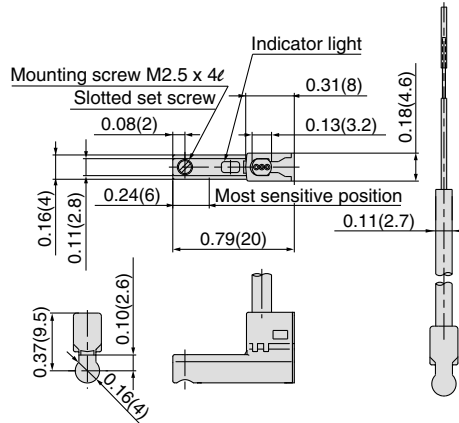

# 2-color Indication Type Solid State Switch Direct Mounting Style

## D-M9NW(V)/D-M9PW(V)/D-M9BW(V)

### Grommet

- 2-wire load current is reduced (2.5 to 40 mA).
- UL certified (style 2844) lead wire cable is used.
- Flexibility is 1.5 times greater than the conventional model (SMC comparison).
- Using flexible cable as standard spec.
- The optimum operating position can be determined by the color of the light. (Red → Green → Red)



### Auto Switch Internal Circuit

#### D-M9NW, M9NWV

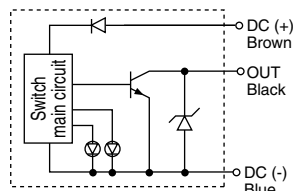

#### D-M9PW, M9PWV

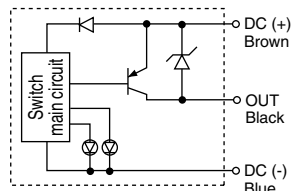

#### D-M9BW, M9BWV

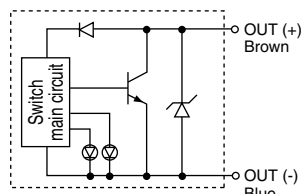

### Indicator light

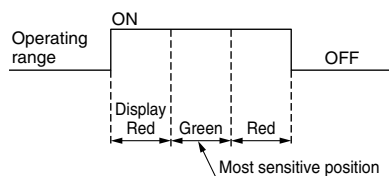

### Auto Switch Specifications

PLC: Programable Logic Controller

D-M9□W, D-M9□WV (With indicator light)						
Auto switch model	D-M9NW	D-M9NWV	D-M9PW	D-M9PWV	D-M9BW	D-M9BWV
Electrical entry direction	In-line	Perpendicular	In-line	Perpendicular	In-line	Perpendicular
Wiring type	3-wire			2-wire		
Output type	NPN		PNP		—	
Applicable load	IC circuit, Relay, PLC				24 VDC relay, PLC	
Power supply voltage	5, 12, 24 VDC (4.5 to 28 V)					—
Current consumption	10 mA or less					—
Load voltage	28 VDC or less		—		24 VDC (10 to 28 VDC)	
Load current	40 mA or less				2.5 to 40 mA	
Internal voltage drop	0.8 V or less at 10 mA (2 V or less at 40 mA)				4 V or less	
Current leakage	100 μA or less at 24 VDC				0.8 mA or less	
Indicator light	Operating position ..... Red LED illuminates. Optimum operating position ..... Green LED illuminates.					
Standard	Conforming to CE Standards					

- Lead wires — Oilproof heavy-duty vinyl cable:  $\phi 2.7 \times 3.2$  ellipse  
 D-M9BW(V)  $2.3 \times 10^{-4} \text{ in}^2 \times 2$  cores  
 D-M9NW(V), D-M9PW(V)  $2.3 \times 10^{-4} \text{ in}^2 \times 3$  cores  
 Note 1) Refer to page 40 for solid state switch common specifications.  
 Note 2) Refer to page 40 for lead wire lengths.

### Weight

Unit: OZ, ( ):g

Model	D-M9NW(V)	D-M9PW(V)	D-M9BW(V)
Lead wire length in(m)			
20(0.5)	0.28( 8)	0.28( 8)	0.25( 7)
39(1 )	0.55(14)	0.55(14)	0.51(13)
118(3 )	1.45(41)	1.45(41)	1.34(38)
197(5 )	2.40(68)	2.40(68)	2.22(63)

### Dimensions

Unit: in

( ): mm

#### D-M9□W

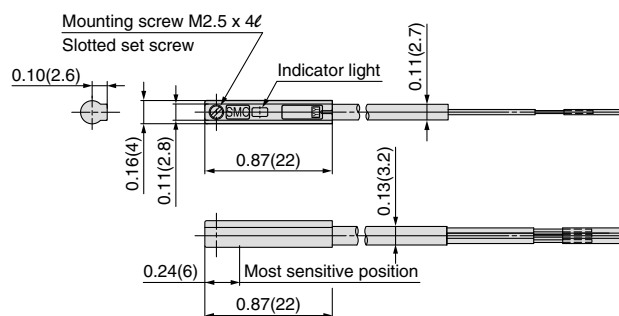

#### D-M9□WV

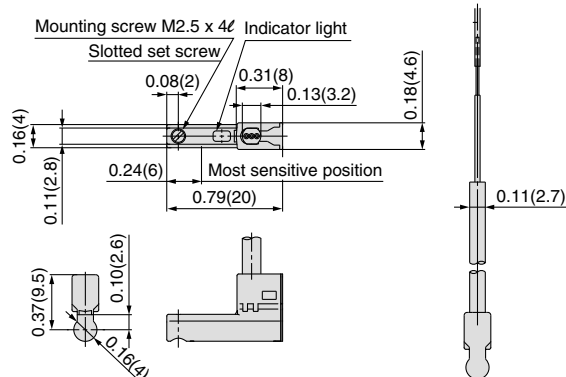

# Water Resistant 2-color Indication Type Solid State Switch: Direct Mounting Style D-F9BAL



## Grommet

### Water (coolant) resistant type

- The optimum operating position can be determined by the color of the light. (Red --> Green --> Red)



## ⚠ Caution

### Operating Precautions

- ① Please consult with SMC if using coolant liquid other than water based solution.
- ② Do not use anything other than the mounting screws attached to the auto switch body to secure the switch. If screws other than those specified are used, it may cause the switch to be damaged.

## Auto Switch Specifications

PLC: Programable Logic Controller

D-F9BAL (With indicator light)	
Auto switch model	<b>D-F9BAL</b>
Wiring type	2-wire
Output type	—
Applicable load	24 VDC relay, PLC
Power supply voltage	—
Current consumption	—
Load voltage	24 VDC (10 to 28 VDC)
Load current	5 to 30 mA
Internal voltage drop	5 V or less
Leakage current	1 mA or less at 24 VDC
Indicator light	Actuated position ..... Red LED lights up Optimum operating position ..... Green LED lights up
Standard	Conforming to CE Standards

### ● Lead wires

Oilproof vinyl heavy -duty cord, 0.11" (ø2.7mm), 20" (0.5m)  
2.8x 10<sup>-4</sup>in<sup>2</sup> (0.18 mm<sup>2</sup>) x 2 cores (Brown, Blue)

Note 1) Refer to page 40 for auto switch common specifications.

Note 2) Refer to page 40 for lead wire lengths.

## Weight

Unit: 1bs, ( ) : g

Model		<b>D-F9BA</b>
Lead wire length in(m)	20(0.5)	—
	118(3 )	1.37(37)
	197(5 )	2.01(57)

## Auto Switch Internal Circuit

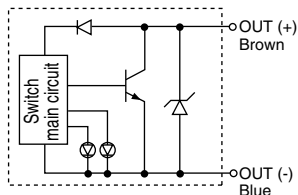

## Indicator light

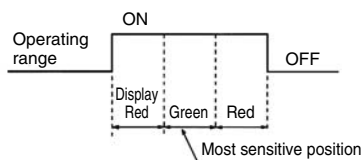

## Dimensions

Unit: in

( ) : mm

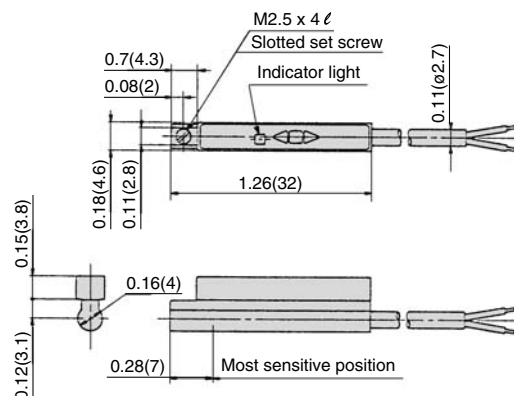





Series **NCQ8**

# Safety Instructions

These safety instructions are intended to prevent a hazardous situation and/or equipment damage. These instructions indicate the level of potential hazard by a label of "**Caution**", "**Warning**" or "**Danger**". To ensure safety, be sure to observe ISO 4414 Note 1), JIS B 8370 Note 2) and other safety practices.

 **Caution** : Operator error could result in injury or equipment damage.

 **Warning** : Operator error could result in serious injury or loss of life.

 **Danger** : In extreme conditions, there is a possible result of serious injury or loss of life.

Note 1) ISO 4414: Pneumatic fluid power – General rules relating to systems

Note 2) JIS B 8370: Pneumatic system axiom

## **Warning**

### **1. The compatibility of pneumatic equipment is the responsibility of the person who designs the pneumatic system or decides its specifications.**

Since the products specified here are used in various operating conditions, their compatibility for the specific pneumatic system must be based on specifications or after analysis and/or tests to meet your specific requirements. The expected performance and safety assurance will be the responsibility of the person who has determined the compatibility of the system. This person should continuously review the suitability of all items specified, referring to the latest catalog information with a view to giving due consideration to any possibility of equipment failure when configuring a system.

### **2. Only trained personnel should operate pneumatically operated machinery and equipment.**

Compressed air can be dangerous if handled incorrectly. Assembly, handling or maintenance of pneumatic systems should be performed by trained and experienced operators.

### **3. Do not service machinery/equipment or attempt to remove components until safety is confirmed.**

1. Inspection and maintenance of machinery/equipment should only be performed once measures to prevent falling or runaway of the driven object have been confirmed.
2. When equipment is to be removed, confirm the safety process as mentioned above. Cut the supply pressure for this equipment and exhaust all residual compressed air in the system.
3. Before machinery/equipment is restarted, take measures to prevent shooting-out of cylinder piston rod, etc.

### **4. Contact SMC if the product is to be used in any of the following conditions:**

1. Conditions and environments beyond the given specifications, or if product is used outdoors.
2. Installation on equipment in conjunction with atomic energy, railway, air navigation, vehicles, medical equipment, food and beverages, recreation equipment, emergency stop circuits, clutch and brake circuit in press applications, or safety equipment.
3. An application which has the possibility of having negative effects on people, property, or animals, requiring special safety analysis.





# Series NCQ8 Actuator Precautions 1

Be sure to read before handling.

## Design

### Warning

- 1. There is a danger of sudden action by air cylinders if sliding parts of machinery are twisted, etc., and changes in forces occur.**

In such cases, bodily injury may occur, e.g., by having hands or get in the machinery, or damage to the machinery itself may occur. Therefore, the machine should be designed to prevent such dangers.

- 2. A protective cover is recommended to minimize the risk of personal injury.**

If a driven object and moving parts of a cylinder pose a danger of personal injury, design the structure to avoid contact with the human body.

- 3. Securely tighten all stationary parts and connected parts so that they will not become loose.**

Particularly when a cylinder operates with high frequency or is installed where there is a lot of vibration, ensure that all parts remain secure.

- 4. A deceleration circuit or shock absorber may be required.**

When a driven object is operated at high speed or the load is heavy, a cylinder's cushion will not be sufficient to absorb the impact. Install a deceleration circuit to reduce the speed before cushioning, or install an external shock absorber to relieve the impact. In cases such as these, the rigidity of the machinery should also be examined.

- 5. Consider a possible drop in operating pressure due to a power outage, etc.**

When a cylinder is used as part of a clamping mechanism, there is a danger of work pieces dropping if there is a decrease in clamping force due to a drop in circuit pressure caused by a power outage, etc. Therefore, safety equipment should be installed to prevent human injury or damage to machinery. Suspension mechanisms and lifting devices also require for drop prevention measures.

- 6. Consider a possible loss of power source.**

Measures should be taken to protect against human injury and equipment damage in the event that there is a loss of power to equipment controlled by pneumatics, electricity or hydraulics, etc.

- 7. Design circuitry to prevent sudden lurching of driven objects.**

Take special care when a cylinder is driven by an exhaust center type directional control valve or when starting up after residual pressure is exhausted from the circuit, etc. The piston and its driven object will lurch at high speed if pressure is applied to one side of the cylinder because of the absence of air pressure inside the cylinder. Therefore, equipment should be selected and circuits designed to prevent sudden lurching because there is a danger of human injury particularly to limbs, and/or damage to equipment when this occurs.

- 8. Consider emergency stops.**

Design the system so that human injury and/or damage to machinery and equipment will not be caused when machinery is stopped by a safety device responding to abnormal conditions such as a power outage or a manual emergency stop.

- 9. Consider the action when operation is restarted after an emergency stop or abnormal stop.**

Design the machinery so that human injury or equipment damage will not occur upon restart of operation. When the cylinder has to be reset at the starting position, install safe manual control equipment.

## Selection

### Warning

- 1. Confirm the specifications.**

The products featured in this catalog are designed for use in industrial compressed air systems. If the products are used in conditions where pressure and/or temperature are out of the range of specifications, damage and/or malfunction may occur. Do not use in these conditions. (Refer to specifications.) Consult SMC if fluid other than compressed air is required.

- 2. Intermediate stops**

When intermediate stopping of a cylinder piston is performed with a 3-position closed center type directional control valve, it is difficult to achieve stopping positions as accurate and precise as with hydraulic pressure due to the compressibility of air.

In addition, since valves and cylinders are not guaranteed for zero air leakage, it may not be possible to hold a stopped position for an extended period of time. Consult SMC in cases where you need to hold a stopped position for long periods.

### Caution

- 1. Operate within the limit of the maximum usable stroke.**

Operation with a stroke exceeding the maximum stroke range will damage the piston rod. Operate within the standard stroke range.

- 2. Operate the piston in such a way that collision damage will not occur at the stroke end.**

- 3. Use a speed controller to adjust the cylinder drive speed, gradually increasing from a low speed to the desired speed setting.**

## Mounting

### Caution

- 1. Be sure to connect so that the rod axis is aligned with the load and movement direction.**

If they are not aligned, stress could be applied to the rod and the tube, causing the inner surface of the tube, the bushing, the rod surface, and the seals to wear and to become damaged.

- 2. When using an external guide, connect the rod end and the load in such a way that there is no interference at any positions within the stroke.**

- 3. Do not scratch or gouge the sliding parts of the cylinder tube or piston rod by striking or grasping them with other objects.**

Cylinder bores are manufactured to precise tolerances, so that even a slight deformation may cause malfunction.

Also, scratches or gouges in the piston rod may lead to damaged seals and cause air leakage.



# Series NCQ8 Actuator Precautions 2

Be sure to read before handling.

## Mounting

### ⚠ Caution

#### 4. Prevent sticking (through friction) of the rotating parts.

Prevent sticking (through friction) of the rotating parts, for example pins, by applying grease.

#### 5. Do not use until you can verify that equipment can operate properly.

Following mounting repairs, or conversions, verify correct mounting by conducting suitable function and leakage tests after piping and power connections have been made.

#### 6. Instruction manual

The product should be mounted and operated after thoroughly reading the manual and understanding its contents. Keep the instruction manual where it can be referred to as needed.

## Piping

### ⚠ Caution

#### 1. Preparation before piping

Before piping is connected, it should be thoroughly blown out with air (flushing) or washed to remove chips, cutting oil, and other debris from inside the pipe.

#### 2. Wrapping of Pipe tape

When screwing together pipes and fittings, etc., be certain that chips from the pipe threads and sealing material do not get inside the piping.

Also, when pipe tape is used, leave 1.5 to 2 thread ridges exposed at the end of the threads.

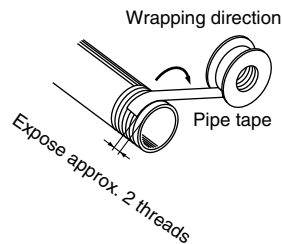

## Lubrication

### ⚠ Caution

#### 1. Lubrication of non-lube type cylinder

The cylinder is lubricated for life at the factory and can be used without any further lubrication.

However, in the event that it is lubricated additionally, be sure to use class 1 turbine oil (with no additives) ISO VG32.

Stopping lubrication later may lead to malfunctions because the new lubricant will cancel out the original lubricant. Therefore, lubrication must be continued once it has been started.

## Air Supply

### ⚠ Warning

#### 1. Use clean air.

Do not use compressed air containing chemicals, synthetic oils containing organic solvents, salt or corrosive gases, as this can cause damage or malfunction.

### ⚠ Caution

#### 1. Install air filters.

Install air filters at the upstream side of valves. The filtration degree should be 5 μm or finer.

#### 2. Install an after-cooler, air dryer or water separator, etc.

Air that includes excessive drainage or condensate may cause malfunction of valves and other pneumatic equipment. To prevent this, install an after-cooler, air dryer or water separator, etc.

#### 3. Use the product within the specified range of fluid and ambient temperature.

Take measures to prevent freezing when 41°F (5°C) or less, since moisture in circuits can freeze and cause damage to seals and lead to malfunctions.

Refer to SMC's Best Pneumatics catalog Vol.14 for further details on compressed air quality.

## Operating Environment

### ⚠ Warning

#### 1. Do not use in environments where there is a danger of corrosion.

#### 2. In dusty locations, or where water or oil may splash on the equipment, install something like a cover to protect the rod.

#### 3. When using auto switches, do not operate in an atmosphere with strong magnetic fields.

## Maintenance

### ⚠ Warning

#### 1. Perform maintenance inspection according to the procedure indicated in the instruction manual.

Improper handling and maintenance may cause malfunctioning and damage of machinery or equipment to occur.

#### 2. Removal of components, and supply/exhaust of compressed air.

When equipment is removed, first check measures to prevent dropping of driven objects and run-away of equipment, etc. Then cut off the supply pressure and electric power, and exhaust all compressed air from the system.

When machinery is restarted, proceed with caution after confirming measures to prevent cylinder lurching.

### ⚠ Caution

#### 1. Filter drainage

Drain out condensate from air filters regularly.



# Series NCQ8 Auto Switch Precautions 1

Be sure to read before handling.

## Design and Selection

### ⚠ Warning

#### 1. Confirm the specifications.

Read the specifications carefully and use this product appropriately. The product may be damaged or malfunction if it is used outside of its specification range (eg. current load, voltage, temperature or impact, etc.).

#### 2. Take precautions when multiple actuators are used close together.

When two or more actuators are lined up in close proximity to each other, magnetic field interference may cause the switches to malfunction. Maintain a minimum cylinder separation of 1.6 in (40 mm).

#### 3. Pay attention to the length of time that a switch is on at an intermediate stroke position.

When an auto switch is placed at an intermediate position of the stroke and a load connected to the auto switch is driven at the time the slide table passes, the auto switch will operate. However if the speed is too great, the operating time will be shortened and the load may not operate properly. The maximum detectable piston speed is:

$$V \text{ (ft/s)} = \frac{\text{Auto switch operating range (ft)}}{\text{Load operating time (ms)}} \times 1000$$

#### 4. Keep wiring as short as possible.

##### <Reed switch>

As the length of the wiring to a load gets longer, the rush current at the time the switch is turned ON becomes greater, which may shorten the product's life. (The switch will stay ON all the time.)

- 1) Use a contact protection box when the wire length is 16.4 ft (5 m) or longer.

##### <Solid state switch>

- 2) Although the wire length should not affect switch function, use a wire that is 328 ft (100 m) or shorter.

- If the wiring is longer it will likely increase noise although the length is less than 328 ft (100 m).

When the wire length is long, we recommend attaching the ferrite core to the both ends of the cable to prevent excess noise.

#### 5. Take precautions for the internal voltage drop of the switch.

##### <Reed switch>

- 1) Switches with an indicator light (Except D-A96, A96V)
  - If auto switches are connected in series as shown below, take note that there will be a large voltage drop because of internal resistance from the light emitting diodes. (Refer to internal voltage drop in the auto switch specifications.) [The voltage drop will be "n" times larger when "n" auto switches are connected.] Even though an auto switch operates normally, the load may not operate.

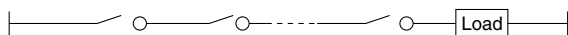

- Similarly, when operating below a specified voltage, it is possible that the load may be ineffective even though the auto switch function is normal. Therefore, the formula below should be satisfied after confirming the minimum operating voltage of the load.

$$\text{Supply voltage} - \text{Internal voltage drop of switch} > \text{Minimum operating voltage of load}$$

- 2) If the internal resistance of a light emitting diode causes a problem, select a switch without an indicator light (Model A90, A90V).

##### <Solid state switch>

- 3) Generally, the internal voltage drop will be greater with a 2-wire solid state auto switch than with a reed switch. Take the same precautions as in item (1) as mentioned above. Also, note that a 12 VDC relay is not applicable.

#### 6. Pay attention to leakage current.

##### <Solid state switch>

With a 2-wire solid state auto switch, current (leakage current) flows to the load to operate the internal circuit even when in the OFF state.

$$\text{Current to operate load (Input OFF signal of controller)} > \text{Leakage current}$$

If the condition given in the above formula is not met, internal circuit will not reset correctly (stays ON). Use a 3-wire switch if this specification cannot be satisfied.

Moreover, leakage current flow to the load will be "n" times larger when "n" auto switches are connected in parallel.

#### 7. Do not use a load that generates surge voltage.

##### <Reed switch>

If driving a load such as a relay which generates a surge voltage, use a contact protection box.

##### <Solid state switch>

Although a zener diode for surge protection is connected at the output side of a solid state auto switch, damage may still occur if a surge is applied repeatedly. When directly driving a load which generates a surge, such as a relay or solenoid valve, use a switch with a built-in surge absorbing element.

#### 8. Cautions for use in an interlock circuit

When an auto switch is used for an interlock signal requiring high reliability, devise a double interlock system to safeguard against malfunctions. The double interlock system should provide a mechanical protection function or use another switch (sensor) together with the auto switch. Also perform periodic inspection and confirm proper operation.

#### 9. Ensure sufficient clearance for maintenance activities.

When designing an application, be sure to allow sufficient clearance for maintenance and inspections.



# Series NCQ8 Auto Switch Precautions 2

Be sure to read before handling.

## Mounting and Adjustment

### ⚠ Warning

#### 1. Do not drop or bump.

Do not drop, bump or apply excessive impacts (984 ft/s<sup>2</sup> or greater for reed switches and 3280 ft/s<sup>2</sup> or greater for solid state switches) while handling.

Although the body of the switch may not be damaged, the inside of the switch could be damaged and cause a malfunction.

#### 2. Do not carry an actuator by the auto switch lead wires.

Never carry a cylinder by its lead wires. This may not only cause broken lead wires, but it may cause internal elements of the switch to be damaged by the stress.

#### 3. Mount switches using the proper tightening torque.

When a switch is tightened above the torque specification, the mounting screws, or switch may be damaged. On the other hand, tightening below the torque specification may allow the switch to slip out of position.

#### 4. Mount a switch at the center of the operating range.

Adjust the mounting position of an auto switch so that the piston stops at the center of the operating range (the range in which a switch is ON). (The mounting positions shown in the catalog indicate the optimum position at the stroke end.) If mounted at the end of the operating range (around the borderline of ON and OFF), operation will be unstable.

##### <D-M9□>

When the D-M9 auto switch is used to replace old series auto switch, it may not activate depending on operating condition because of its shorter operating range.

Such as

- Application where the stop position of actuator may vary and exceed the operating range of the auto switch, for example, pushing, pressing, clamping operation, etc.
- Application where the auto switch is used for detecting an intermediate stop position of the actuator. (In this case the detecting time will be reduced.)

In these applications, please set the auto switch to the center of the required detecting range.

### ⚠ Caution

#### 1. Fix the switch with the appropriate screw installed on the switch body. The switch may be damaged if other screws are used.

## Wiring

### ⚠ Warning

#### 1. Avoid repeatedly bending or stretching lead wires.

Broken lead wires will result from repeatedly applying bending stress or stretching force to the lead wires.

Stress and tensile force applied to the connection between the cable and switch increases the possibility of disconnection.

Fix the cable in the middle so that it is not movable in the area where it connects with the switch.

#### 2. Be sure to connect the load before power is applied.

##### <2-wire type>

If the power is turned ON when an auto switch is not connected to a load, the switch will be instantly damaged because of excess current.

It is the same as when the 2-wire brown cord (+, output) is directly connected to the (+) power supply terminal.

#### 3. Confirm proper insulation of wiring.

Be certain that there is no faulty wiring insulation (such as contact with other circuits, ground fault, improper insulation between terminals, etc.). Damage may occur due to excess current flow into a switch.

#### 4. Do not wire in conjunction with power lines or high voltage lines.

Wire separately from power lines or high voltage lines, avoiding parallel wiring or wiring in the same conduit with these lines. Control circuits containing auto switches may malfunction due to noise from these lines.

#### 5. Do not allow short circuit of loads.

##### <Reed switch>

If the power is turned ON with a load in a short circuited condition, the switch will be instantly damaged because of excess current flow into the switch.

##### <Solid state switch>

D-M9□ and all models of PNP output type switches do not have built-in short circuit protection circuits. If loads are short circuited, the switches will be instantly damaged, as in the case of reed switches.

Take special care to avoid reverse wiring with the brown power supply line and the black output line on 3-wire type switches.

#### 6. Avoid incorrect wiring.

##### <Reed switch>

A 24 VDC switch with indicator light has polarity. The brown lead wire is (+), and the blue lead wire is (-).

- 1) If connections are reversed, the switch will still operate, but the light emitting diode will not light up.

Also note that a current greater than the maximum specified one will damage a light emitting diode and make it inoperable. Applicable models: D-A93, A93V

##### <Solid state switch>

- 1) Even if connections are reversed on a 2-wire type switch, the switch will not be damaged because it is protected by a protection circuit, but it will remain in a normally ON state. But reverse wiring in a short circuit load condition should be avoided to protect the switch from being damaged.

- 2) Even if (+) and (-) power supply line connections are reversed on a 3-wire type switch, the switch will be protected by a protection circuit. However, if the (+) power supply line is connected to the blue wire and the (-) power supply line is connected to the black wire, the switch will be damaged.



# Series NCQ8

## Auto Switch Precautions 3

Be sure to read before handling.

### Wiring

#### ⚠ Warning

<D-M9□>

D-M9□ does not have built-in short circuit protection circuit. Be aware that if the power supply connection is reversed (e.g. (+) power supply wire and (-) power supply wire connection is reversed), the switch will be damaged.

#### \* Lead wire color changes

Lead wire colors of SMC switches have been changed in order to meet NECA Standard 0402 for production beginning September, 1996 and thereafter. Please refer to the tables provided. Special care should be taken regarding wire polarity during the time that the old colors still coexist with the new colors.

##### 2-wire

	Old	New
Output (+)	Red	Brown
Output (-)	Black	Blue

##### 3-wire

	Old	New
Power supply	Red	Brown
GND	Black	Blue
Output	White	Black

#### ⚠ Caution

1. When the cable sheath is stripped, confirm the stripping direction. The insulator may be split or damaged depending on the direction. (D-M9□ only)

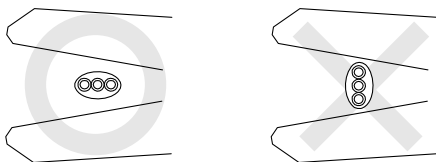

#### Recommended tool

Manufacturer	Model name	Model no.
VESSEL	Wire stripper	No 3000G
TOKYO IDEAL CO., LTD	Strip master	45-089

\* Stripper for a round cable (ø2.0) can be used for a 2-wire type cable.

\* Tool model no. : D-M9N-SWY

### Operating Environment

#### ⚠ Warning

1. **Never use in an atmosphere of explosive gases.**  
The construction of the auto switch is not intended to prevent explosion. Never use in an atmosphere with an explosive gas since this may cause a serious explosion.
2. **Do not use in an area where a magnetic field is generated.**  
The auto switch will malfunction or the magnets inside of an actuator will become demagnetized if used in such an environment.
3. **Do not use in an environment where the auto switch will be continually exposed to water.**  
The switch satisfies the IEC standard IP67 construction (JIS C 0920: watertight construction). Nevertheless, it should not be used in applications where it is continually exposed to water splash or spray. This may cause deterioration of the insulation or swelling of the potting resin inside switch causing malfunction.
4. **Do not use in an environment with oil or chemicals.**  
Consult with SMC if an auto switch will be used in an environment laden with coolant, cleaning solvent, various oils or chemicals. If an auto switch is used under these conditions for even a short time, it may be adversely effected by deterioration of insulation, malfunction due to swelling of the potting resin, or hardening of the lead wires.
5. **Do not use in an environment with temperature cycles.**  
Consult with SMC if a switch is used where there are temperature cycles other than normal temperature changes, as they may adversely affect a switch internally.
6. **Do not use in an environment where there is excessive impact shock.**  
<Reed switch>  
When excessive impact (984 ft/s<sup>2</sup> or more) is applied to a reed switch during operation, the contact point may malfunction and generate a signal momentarily (1 ms or less) or cut off. Consult with SMC regarding the need to use a solid state switch in a specific environment.
7. **Do not use in an area where surges are generated.**  
<Solid state switch>  
When there are units (such as solenoid type lifters, high frequency induction furnaces, motors, etc.) that generate a large amount of surge in the area around an actuator with a solid state auto switch, their proximity or pressure may cause deterioration or damage to the internal circuit of a switch. Avoid sources of surge generation and crossed lines.
8. **Avoid accumulation of iron debris or close contact with magnetic substances.**  
When a large amount of ferrous debris such as machining chips or spatter is accumulated, or a magnetic substance (something attracted by a magnet) is brought into close proximity with an auto switch cylinder, it may cause auto switches to malfunction due to a loss of the magnetic force inside the cylinder.



## Series NCQ8

# Auto Switch Precautions 4

Be sure to read before handling.

### Maintenance

#### Warning

**1. Perform the following maintenance periodically in order to prevent possible danger due to unexpected auto switch malfunction.**

- 1) Securely tighten switch mounting screws.  
If screws become loose or the mounting position is dislocated, retighten them after readjusting the mounting position.
- 2) Confirm that there is no damage to the lead wires.  
To prevent faulty insulation, replace switches or repair lead wires, etc., if damage is discovered.
- 3) Confirm that the green light on the 2-color display type switch lights up.  
Confirm that the green LED is ON when stopped at the set position. If the red LED is ON, when stopped at the set position, the mounting position is not appropriate. Readjust the mounting position until the green LED lights up.

### Other

#### Warning

**1. Consult with SMC concerning water resistance, elasticity of lead wires, usage at welding sites, etc.**



# Series *NCQ8* Specific Product Precautions

Be sure to read before handling.

## Snap Ring Installation/Removal

### **Caution**

1. For installation and removal, use an appropriate pair of pliers (Tool for installing a type C snap ring).
2. Even if a proper plier (tool for installing type C snap ring) is used, it is likely to inflict damage to a human body or peripheral equipment, as a snap ring may be flown out of the tip of a plier (tool for installing a type C snap ring).

Be much careful with the popping of a snap ring. Besides, be certain that a snap ring is placed firmly into the groove of rod cover before supplying air at the time of installment. After re-installing the cylinder, make sure that the snap ring is placed securely in the groove before supplying air.

### **Fixing a workpiece**

When you fix a workpiece on the piston rod, apply the adhesive to the holding bolt to prevent it from being loosened due to vibration, etc.

# Global Manufacturing, Distribution and Service Network

## Worldwide Subsidiaries

### EUROPE

**AUSTRIA**  
SMC Pneumatik GmbH

**BELGIUM**  
SMC Pneumatics N.V./S.A.

**BULGARIA**  
SMC Industrial Automation Bulgaria EOOD

**CROATIA**  
SMC Industrijska automatika d.o.o.

**CZECH REPUBLIC**  
SMC Industrial Automation CZ s.r.o.

**DENMARK**  
SMC Pneumatik A/S

**ESTONIA**  
SMC Pneumatics Estonia OÜ

**FINLAND**  
SMC Pneumatics Finland OY

**FRANCE**  
SMC Pneumatique SA

**GERMANY**  
SMC Pneumatik GmbH

**GREECE**  
SMC Hellas EPE

**HUNGARY**  
SMC Hungary Ipari Automatizálási Kft.

**IRELAND**  
SMC Pneumatics (Ireland) Ltd.

**ITALY**  
SMC Italia S.p.A.

**LATVIA**  
SMC Pneumatics Latvia SIA

**LITHUANIA**  
SMC Pneumatics Lietuva, UAB

**NETHERLANDS**  
SMC Pneumatics BV.

**NORWAY**  
SMC Pneumatics Norway A/S

**POLAND**  
SMC Industrial Automation Polska Sp.z.o.o.

**ROMANIA**  
SMC Romania s.r.l.

**RUSSIA**  
SMC Pneumatik LLC.

**SLOVAKIA**  
SMC Priemyselná automatizácia, s.r.o.

**SLOVENIA**  
SMC INDUSTRIJSKA AVTOMATIKA d.o.o.

**SPAIN/PORTUGAL**  
SMC España, S.A.

**SWEDEN**  
SMC Pneumatics Sweden AB

**SWITZERLAND**  
SMC Pneumatik AG.

**UK**  
SMC Pneumatics (U.K.) Ltd.

### ASIA

**CHINA**  
SMC (China) Co., Ltd.

**HONG KONG**  
SMC Pneumatics (Hong Kong) Ltd.

**INDIA**  
SMC Pneumatics (India) Pvt. Ltd.

**INDONESIA**  
PT. SMC Pneumatics Indonesia

**MALAYSIA**  
SMC Pneumatics (S.E.A.) Sdn. Bhd.

**PHILIPPINES**  
SHOKETSU-SMC Corporation

**SINGAPORE**  
SMC Pneumatics (S.E.A.) Pte. Ltd.

**SOUTH KOREA**  
SMC Pneumatics Korea Co., Ltd.

**TAIWAN**  
SMC Pneumatics (Taiwan) Co., Ltd.

**THAILAND**  
SMC Thailand Ltd.

### NORTH AMERICA

**CANADA**  
SMC Pneumatics (Canada) Ltd.

**MEXICO**  
SMC Corporation (Mexico) S.A. de C.V.

**USA**  
SMC Corporation of America

### SOUTH AMERICA

**ARGENTINA**  
SMC Argentina S.A.

**BOLIVIA**  
SMC Pneumatics Bolivia S.R.L.

**BRAZIL**  
SMC Pneumaticos Do Brazil Ltda.

**CHILE**  
SMC Pneumatics (Chile) S.A.

**VENEZUELA**  
SMC Neumatica Venezuela S.A.

### OCEANIA

**AUSTRALIA**  
SMC Pneumatics (Australia) Pty. Ltd.

**NEW ZEALAND**  
SMC Pneumatics (N.Z.) Ltd.

## U.S. & Canadian Sales Offices

### EAST

**Atlanta**  
Tel: (770) 624-1940  
Fax: (770) 624-1943

**Boston**  
Tel: (603) 610-2500  
Fax: (603) 610-2600

**Charlotte**  
Tel: (704) 947-7556  
Fax: (704) 947-8556

**Nashville**  
Tel: (615) 778-0442  
Fax: (615) 778-0475

**New Jersey**  
Tel: (973) 285-3207  
Fax: (973) 538-0503

**Richmond**  
Tel: (804) 527-2106  
Fax: (804) 527-2154

**Rochester**  
Tel: (585) 381-3912  
Fax: (585) 381-3941

**Tampa**  
Tel: (813) 891-9028  
Fax: (813) 891-9340

### MIDWEST

**Chicago**  
Tel: (630) 449-0600  
Fax: (630) 449-0601

**Cincinnati**  
Tel: (859) 647-5601  
Fax: (859) 647-5609

**Cleveland**  
Tel: (330) 659-2006  
Fax: (330) 659-2260

**Detroit**  
Tel: (248) 299-0202  
Fax: (248) 293-3333

**Indianapolis**  
Tel: (603) 610-2503  
Fax: (317) 898-3896

**Milwaukee**  
Tel: (262) 253-4801  
Fax: (262) 253-4802

**Minneapolis**  
Tel: (952) 943-1207  
Fax: (952) 943-1614

**St. Louis**  
Tel: (314) 298-2521  
Fax: (314) 298-5896

### WEST

**Austin**  
Tel: (512) 926-2646  
Fax: (512) 926-7055

**Dallas**  
Tel: (972) 446-1140  
Fax: (972) 446-1251

**Los Angeles**  
Tel: (714) 669-1701  
Fax: (714) 669-1715

**Phoenix**  
Tel: (480) 967-2570  
Fax: (480) 829-0824

**Portland**  
Tel: (503) 644-1696  
Fax: (503) 644-4041

**San Jose**  
Tel: (408) 943-9600  
Fax: (408) 943-9111

### CANADA

**Montreal**  
Tel: (514) 733-9595  
Fax: (514) 733-1771

**Toronto**  
Tel: (905) 812-0400  
Fax: (905) 812-8686

**Vancouver**  
Tel: (604) 517-1646  
Fax: (604) 517-1647

**Windsor**  
Tel: (519) 944-0555  
Fax: (519) 944-1870

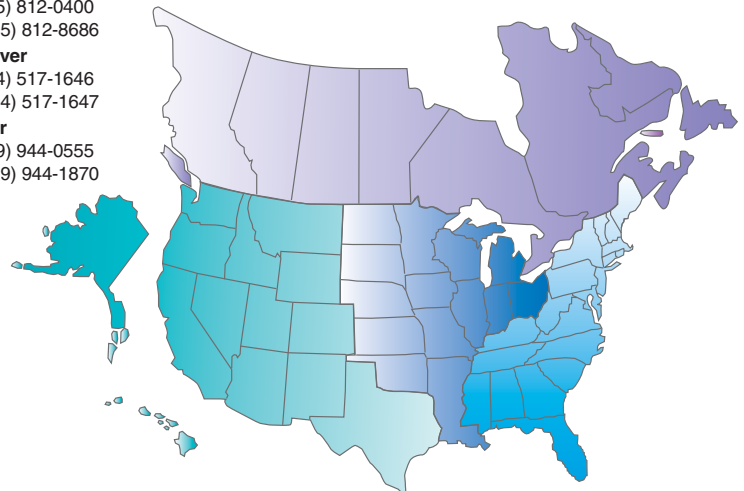

**SMC Corporation of America**  
3011 N. Franklin Road  
Indianapolis IN 46226  
(317) 899-4845  
www.smcusa.com

**SMC Pneumatics (Canada) Ltd.**  
6768 Financial Drive Mississauga  
Ontario L5N 7J6 Canada  
(905) 812-0400  
www.smcpcanada.ca

Call 1-800-SMC-SMC1 (1-800-762-7621) to reach the branch nearest you

