

Pilot Operated 2 Port Solenoid Valve

For Water, Oil, Air



New
VXD Series **VXD21/22/23**

Solenoid valves for various fluids used in a wide variety of

Improvement of corrosion resistance

Special magnetic material adopted

Enclosure: IP65

Low noise construction

Special construction enables to reduce the metal noise. (DC specification)

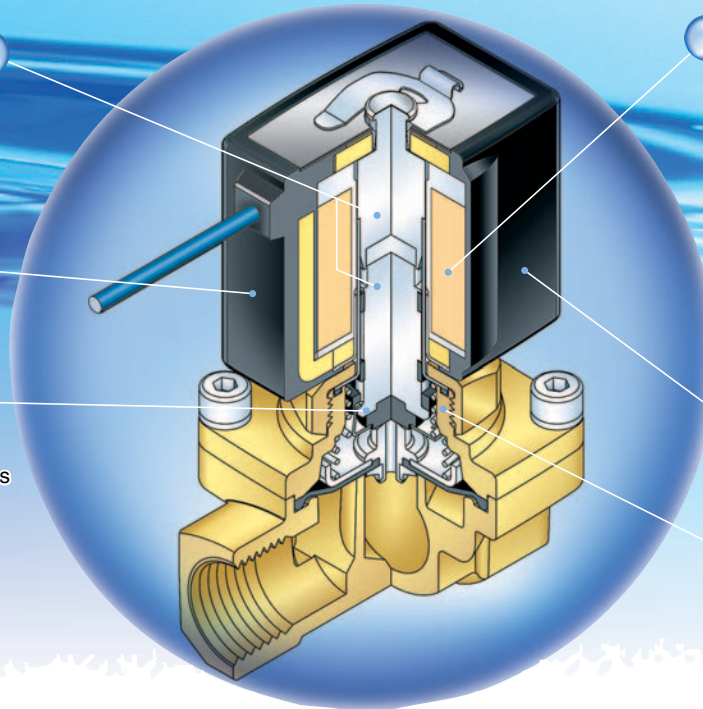

Reduction of power consumption (DC specification)

VXD21: 6 W

→ **4.5 W** (VXD2140 to 2150)

→ **5.5 W** (VXD2130)

VXD22: 8 W → **7 W**

VXD23: 11.5 W

→ **10.5 W**

Flame resistance UL94V-0 conformed

Flame resistant mold coil material

Improvement of maintenance performance

Maintenance is performed easily due to the threaded assembly.

Pilot Operated 3 Port Solenoid Valve

For Water, Oil, Air

New Series VXD21/22/23

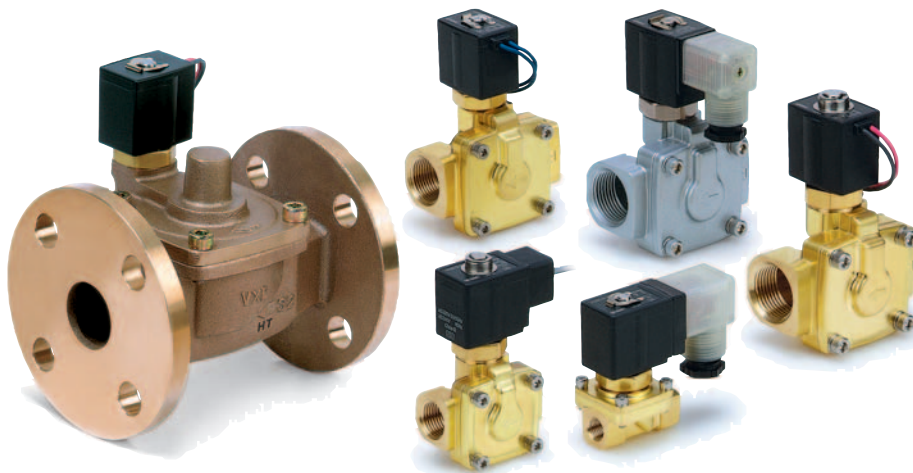

Normally Closed (N.C.)

Solenoid valve (Port size)				Orifice size						Material		
Model	VXD21	VXD22	VXD23	3 (10 mm)	4 (15 mm)	5 (20 mm)	6 (25 mm)	7 (35 mm)	8 (40 mm)	9 (50 mm)	Body	Seal
Port no. (Port size)	Thread	02 (1/4)	—	—	●	—	—	—	—	—	Brass (C37) Stainless steel	NBR FKM EPDM
		03 (3/8)	—	—	●	—	—	—	—	—		
		04 (1/2)	—	—	—	●	—	—	—	—		
		06 (3/4)	—	—	—	—	●	—	—	—		
	Flange	—	10 (1)	—	—	—	—	●	—	—	CAC407	
		—	32 (32A)	—	—	—	—	—	●	—		
—	—	—	40 (40A)	—	—	—	—	—	●	—	—	
—	—	—	50 (50A)	—	—	—	—	—	—	●	—	

Normally Open (N.O.)

Solenoid valve (Port size)				Orifice size					Material			
Model	VXD21	VXD22	VXD23	4 (15 mm)	5 (20 mm)	6 (25 mm)	7 (35 mm)	8 (40 mm)	9 (50 mm)	Body	Seal	
Port no. (Port size)	Thread	03 (3/8)	—	—	●	—	—	—	—	Brass (C37) Stainless steel	NBR FKM EPDM	
		04 (1/2)	—	—	●	—	—	—	—			
		06 (3/4)	—	—	—	●	—	—	—			—
		—	10 (1)	—	—	—	●	—	—			—
	Flange	—	32 (32A)	—	—	—	—	●	—	—		CAC407
		—	—	40 (40A)	—	—	—	—	●	—		
—	—	—	50 (50A)	—	—	—	—	—	●	—		

applications — **New VX Series variations**

Direct Operated 2 Port

VX21/22/23

For Air, Vacuum, Water, Steam, Oil



Valve type	Port size	Orifice size mmØ
N.C./N.O.	1/8 to 1/2	2 to 10

Pilot Operated 2 Port for Zero Differential Pressure

VXZ22/23

For Air, Vacuum, Water, Oil

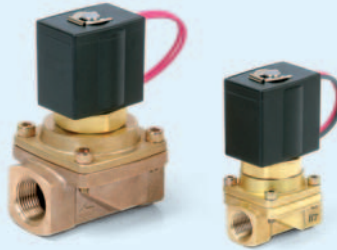

Valve type	Port size	Orifice size mmØ
N.C./N.O.	1/4 to 1	10 to 25

Direct Operated 3 Port

VX31/32/33

For Air, Vacuum, Water, Steam, Oil



Valve type	Port size	Orifice size mmØ
N.C./N.O. COM.	1/8 to 3/8	1.5 to 4

Pilot Operated 2 Port

VXP21/22/23

For Steam (Air, Water, Oil)



Valve type	Port size	Orifice size mmØ
N.C./N.O.	1/4 to 2 32A to 50A	10 to 50

Water Hammer Relief, Pilot Operated 2 Port

VXR21/22/23

For Water, Oil



Valve type	Port size	Orifice size mmØ
N.C./N.O.	1/2 to 2	20 to 50

Pilot Operated 2 Port for High Pressure

VXH22

For Air, Water, Oil

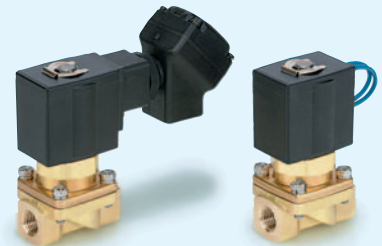

Valve type	Port size	Orifice size mmØ
N.C.	1/4 to 1/2	10

2 Port for Dust Collector (Solenoid type, Air Operated type)

VXF21/22, VXF21/22

For Air

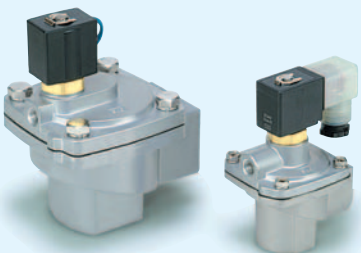

Valve type	Port size	Orifice size mmØ
N.C.	3/4 to 1 1/2	20 to 40

Air Operated 2/3 Port

VXA21/22, VXA31/32

For Air, Vacuum, Water, Oil



Model	Valve type	Port size	Orifice size mmØ
VXA21/22	N.C./N.O.	1/8 to 1/2	3 to 10
VXA31/32	COM.	1/8 to 3/8	1.5 to 4

The VX series has been renewed as the **new VX series**, with a new construction

Solenoid Valves Flow Characteristics

(How to indicate flow characteristics)

1. Indication of flow characteristics

Indication of the flow characteristics in specifications for equipment such as solenoid valve, etc. is depending on "Table (1)"

Table (1) Indication of Flow Characteristics

Corresponding equipment	Indication by international standard	Other indications	Standards conforming to
Equipment for pneumatics	C, b	—	ISO 6358: 1989 JIS B 8390: 2000
	—	S	JIS B 8390: 2000 Equipment: JIS B 8373, 8374, 8375, 8379, 8381
		C_v	ANSI/(NFPA)T3.21.3: 1990
Equipment for controlling process fluids	A_v	—	IEC60534-2-3: 1997 JIS B 2005: 1995
	—	C_v	Equipment: JIS B 8471, 8472, 8473

2. Equipment for pneumatics

2.1 Indication according to the international standards

(1) Standards conforming to

- ISO 6358: 1989** Pneumatic fluid power—Components using compressible fluids—
Determination of flow-rate characteristics
- JIS B 8390: 2000** Pneumatic fluid power—Components using compressible fluids—
How to test flow rate characteristics

(2) Definition of flow characteristics

Flow rate characteristics are indicated as a result of a comparison between sonic conductance C and critical pressure ratio b .

Sonic conductance C Values which divide the passing mass flow rate of an equipment in a choked flow condition by the product of the upstream absolute pressure and the density in the standard condition

Critical pressure ratio b It is the pressure ratio which will turn to the choke flow (downstream pressure/upstream pressure) when it is smaller than this values. (critical pressure ratio)

Choked flow It is the flow in which the upstream pressure is higher than the downstream pressure and where sonic speed in a certain part of an equipment is reached.
Gaseous mass flow rate is in proportion to the upstream pressure and not dependent on the downstream pressure. (choked flow)

Subsonic flow Flow greater than the critical pressure ratio

Standard condition Air in a temperature state of 20°C, absolute pressure 0.1 MPa (= 100 kPa = 1 bar), relative humidity 65%.

It is stipulated by adding the abbreviation (ANR) after the unit depicting air volume. (standard reference atmosphere)

Standard conforming to: ISO 8778: 1990 Pneumatic fluid power—Standard reference atmosphere, JIS B 8393: 2000: Pneumatic fluid power—Standard reference atmosphere

(3) Formula of flow rate

It can be indicated by the practical unit as following.

When

$$\frac{P_2 + 0.1}{P_1 + 0.1} \leq b, \text{ choked flow}$$

$$Q = 600 \times C (P_1 + 0.1) \sqrt{\frac{293}{273 + t}} \dots\dots\dots(1)$$

When

$$\frac{P_2 + 0.1}{P_1 + 0.1} > b, \text{ subsonic flow}$$

$$Q = 600 \times C (P_1 + 0.1) \sqrt{1 - \left[\frac{\frac{P_2 + 0.1}{P_1 + 0.1}}{b} \right]^2} \sqrt{\frac{293}{273 + t}} \dots\dots\dots(2)$$

Q Air flow rate [dm³/min (ANR)], dm³ (Cubic decimeter) of SI unit are also allowed to described by ℓ (liter). 1 dm³ = 1 ℓ .

Solenoid Valves Flow Characteristics

- C Sonic conductance [$\text{dm}^3/(\text{s}\cdot\text{bar})$]
- b Critical pressure ratio [—]
- P_1 Upstream pressure [MPa]
- P_2 Downstream pressure [MPa]
- t Temperature [$^{\circ}\text{C}$]

Note) Formula of subsonic flow is the elliptic analogous curve.

Flow characteristics curve is indicated in the Graph (1) For details, please use SMC's "Energy Saving Program"

Example)

Obtain the air flow rate for $P_1 = 0.4$ [MPa], $P_2 = 0.3$ [MPa], $t = 20$ [$^{\circ}\text{C}$] when a solenoid valve is performed in $C = 2$ [$\text{dm}^3/(\text{s}\cdot\text{bar})$] and $b = 0.3$.

According to formula 1, the maximum flow rate = $600 \times 2 \times (0.4 + 0.1) \times \sqrt{\frac{293}{273 + 20}} = 600$ [dm^3/min (ANR)]

$$\text{Pressure ratio} = \frac{0.3 + 0.1}{0.4 + 0.1} = 0.8$$

Based on the Graph (1), it is going to be 0.7 if it is read by the pressure ratio as 0.8 and the flow ratio to be $b = 0.3$.
Hence, flow rate = Max. flow \times flow ratio = $600 \times 0.7 = 420$ [dm^3/min (ANR)]

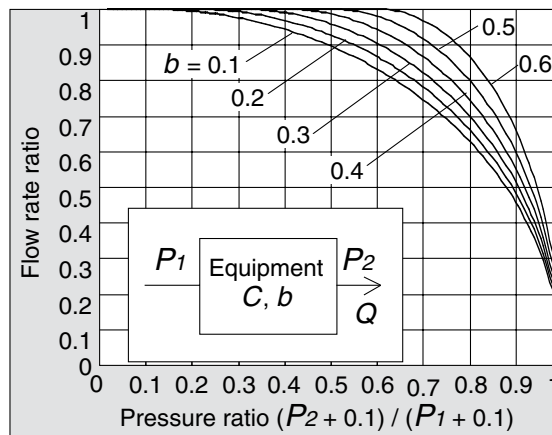

Graph (1) Flow characteristics line

(4) Test method

By attaching a test equipment with the test circuit indicated in Fig. (1) while maintaining to a certain amount which does not let the upstream pressure go down below 0.3 MPa, measure the maximum flow to be saturated in the first place. Next, measure this flow rate at 80%, 60%, 40%, 20% and the upstream and downstream pressure. And then, obtain the sonic conductance C from this maximum flow rate. Besides that, substitute each data of others for the formula of subsonic flow in order to find b , then obtain the critical pressure ratio b from that average.

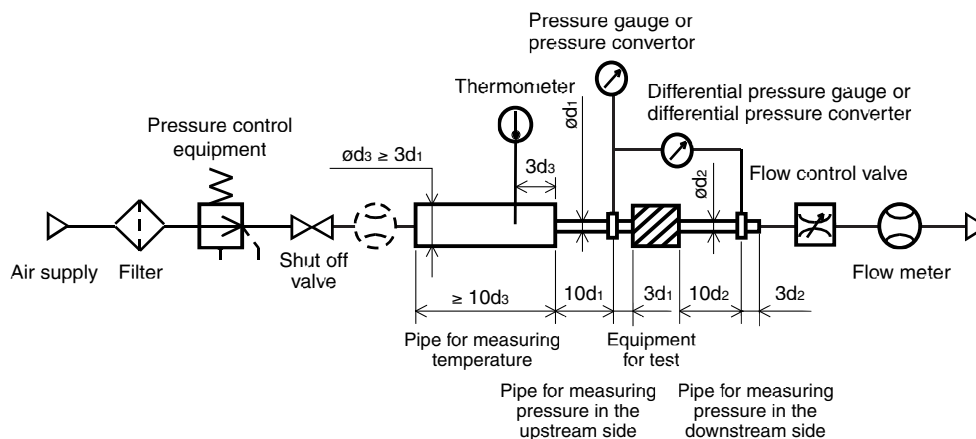

Fig. (1) Test circuit based on ISO 6358, JIS B 8390

Solenoid Valves Flow Characteristics

2.2 Effective area S

(1) Standards conforming to

JIS B 8390: 2000: Pneumatic fluid power—Components using compressible fluids—Determination of flow rate characteristics

Equipment standards: JIS B 8373: 2 port solenoid valve for pneumatics

JIS B 8374: 3 port solenoid valve for pneumatics

JIS B 8375: 4 port, 5 port solenoid valve for pneumatics

JIS B 8379: Silencer for pneumatics

JIS B 8381: Fittings of flexible joint for pneumatics

(2) Definition of flow characteristics

Effective area S : is the cross-sectional area having an ideal throttle without friction deduced from the calculation of the pressure changes inside an air tank or without reduced flow when discharging the compressed air in a choked flow, from an equipment attached to the air tank. This is the same concept representing the “easy to run through” as sonic conductance C (effective area).

(3) Formula of flow rate

When

$\frac{P_2 + 0.1}{P_1 + 0.1} \leq 0.5$, **choked flow**

$$Q = 120 \times S (P_1 + 0.1) \sqrt{\frac{293}{273 + t}} \dots\dots\dots(3)$$

When

$\frac{P_2 + 0.1}{P_1 + 0.1} > 0.5$, **subsonic flow**

$$Q = 240 \times S \sqrt{(P_2 + 0.1) (P_1 - P_2)} \sqrt{\frac{293}{273 + t}} \dots\dots\dots(4)$$

Conversion with sonic conductance C :

$$S = 5.0 \times C \dots\dots\dots(5)$$

Q : Air flow rate [dm³/min(ANR)], dm³ (cubic decimeter) of SI unit is good to be described by ℓ (liter), too. 1 dm³ = 1 ℓ

S : Effective area [mm²]

P_1 : Upstream pressure [MPa]

P_2 : Downstream pressure [MPa]

t : Temperature [°C]

Note) Formula for subsonic flow (4) is only applicable when the critical pressure ratio b is the unknown equipment. In the formula by sonic conductance C (2), it is the same formula when $b = 0.5$.

(4) Test method

By attaching the equipment for testing with the test circuit shown in Fig. (2), discharge air into the atmosphere until the pressure inside the air tank goes down to 0.25 MPa (0.2 MPa) from an air tank filled with compressed air of a certain pressure (0.5 MPa) which does not go down below 0.6 MPa. At this time, measure the discharging time and the residual pressure inside the air tank which had been left until it turned to be the normal values, and then determine the effective area S by using the following formula. The volume of air tank should be selected within the specified range by corresponding to the effective area of the equipment being tested. In the case of JIS B 8373, 8374, 8375, 8379, 8381, the pressure values are in parentheses and the coefficient of formula is 12.9.

$$S = 12.1 \frac{V}{t} \log_{10} \left(\frac{P_s + 0.1}{P + 0.1} \right) \sqrt{\frac{293}{T}} \dots\dots\dots(6)$$

S : Effective area [mm²]

V : Air tank capacity [dm³]

t : Discharging time [s]

P_s : Pressure inside air tank before discharging [MPa]

P : Residual pressure inside air tank after discharging [MPa]

T : Temperature inside air tank before discharging [K]

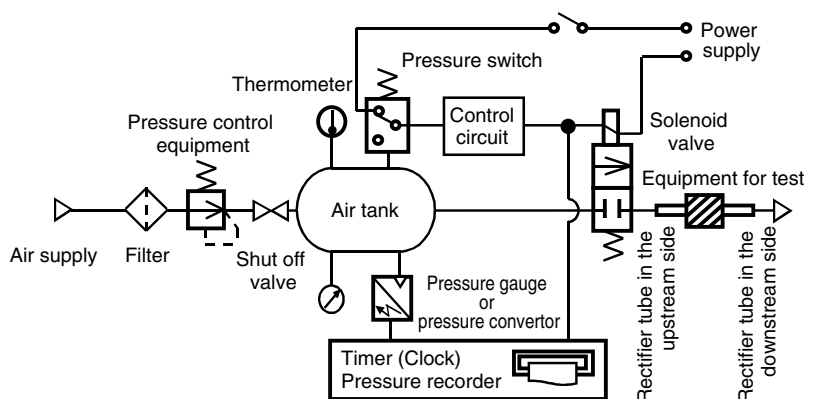

Fig. (2) Test circuit based on JIS B 8390

Solenoid Valves Flow Characteristics

2.3 Flow coefficient C_v factor

The United States Standard ANSI/(NFPA)T3.21.3:1990: Pneumatic fluid power—Flow rating test procedure and reporting method for fixed orifice components

defines the C_v factor of flow coefficient by the following formula which is based on the test conducted by the test circuit analogous to ISO 6358.

$$C_v = \frac{Q}{114.5 \sqrt{\frac{\Delta P (P_2 + P_a)}{T_1}}} \dots\dots\dots(7)$$

ΔP Pressure drop between the static pressure tapping ports [bar]

P_1 Pressure of the upstream tapping port [bar gauge]

P_2 Pressure of the downstream tapping port [bar gauge]: $P_2 = P_1 - \Delta P$

Q Flow rate [dm³/s standard condition]

P_a Atmospheric pressure [bar absolute]

T_1 Test conditions of the upstream absolute temperature [K]

is $< P_1 + P_a = 6.5 \pm 0.2$ bar absolute, $T_1 = 297 \pm 5$ K, $0.07 \text{ bar} \leq \Delta P \leq 0.14$ bar.

This is the same concept as effective area A which ISO6358 stipulates as being applicable only when the pressure drop is smaller than the upstream pressure and the compression of air does not become a problem.

3. Equipment for process fluids

(1) Standards conforming to

IEC60534-2-3: 1997: Industrial process control valves. Part 2: Flow capacity, Section Three-Test procedures

JIS B 2005: 1995: Test method for the flow coefficient of a valve

Equipment standards: JIS B 8471 Regulator for water

JIS B 8472: Solenoid valve for steam

JIS B 8473: Solenoid valve for fuel oil

(2) Definition of flow characteristics

A_v factor: Value of the clean water flow rate represented by m³/s which runs through a valve (equipment for test) when the pressure difference is 1 Pa. It is calculated using the following formula.

$$A_v = Q \sqrt{\frac{\rho}{\Delta P}} \dots\dots\dots(8)$$

A_v Flow coefficient [m²]

Q Flow rate [m³/s]

ΔP Pressure difference [Pa]

ρ Density of fluid [kg/m³]

(3) Formula of flow rate

It is described by the known unit. Also, the flow characteristics line shown in the Graph (2).

In the case of liquid:

$$Q = 1.9 \times 10^6 A_v \sqrt{\frac{\Delta P}{G}} \dots\dots\dots(9)$$

Q Flow rate [ℓ/min]

A_v Flow coefficient [m²]

ΔP Pressure difference [MPa]

G Relative density [water = 1]

In the case of saturated aqueous vapor:

$$Q = 8.3 \times 10^6 A_v \sqrt{\Delta P (P_2 + 0.1)} \dots\dots\dots(10)$$

Q Flow rate [m³/s]

A_v Flow coefficient [m²]

ΔP Pressure difference [Pa]

P_1 Relative density [MPa]: $\Delta P = P_1 - P_2$

P_2 Relative density [MPa]

Solenoid Valves Flow Characteristics

Conversion of flow coefficient:

$$Av = 28 \times 10^{-6} Kv = 24 \times 10^{-6} Cv \dots\dots\dots(11)$$

Here,

Kv factor: Value of the clean water flow rate represented by the m³/h which runs through the valve at 5 to 40°C, when the pressure difference is 1 bar.

Cv factor (Reference values): It is the figures representing the flow rate of clean water by US gal/min which runs through the valve at 60°F, when the pressure difference is 1 lbf/in² (psi).

Values of pneumatic *Kv* are different from *Cv* because the testing method is different from each other.

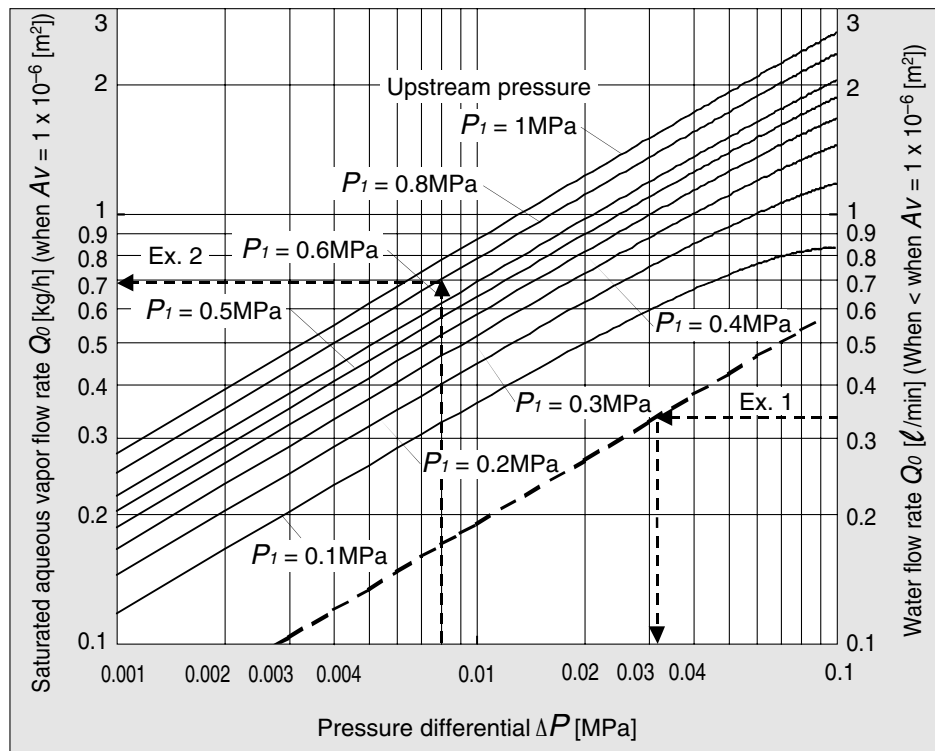

Graph (2) Flow characteristics line

Example 1

Obtain the pressure difference when water 15 [l/min] runs through the solenoid valve with an $Av = 45 \times 10^{-6} [m^2]$. Since $Q_0 = 15/45 = 0.33 [l/min]$, according to the Graph (2), if reading ΔP when Q_0 is 0.33, it will be 0.031 [MPa].

Example 2)

Obtain the flow rate of saturated aqueous vapor when $P_1 = 0.8 [MPa]$, $\Delta P = 0.008 [MPa]$ with a solenoid valve with an $Av = 1.5 \times 10^{-6} [m^2]$.

According to the Graph (2), if reading Q_0 when P_1 is 0.8 and ΔP is 0.008, it is 0.7 [kg/h]. Hence, the flow rate $Q = 0.7 \times 1.5 = 1.05 [kg/h]$.

Solenoid Valves Flow Characteristics

(4) Test method

By attaching the equipment for testing with the test circuit shown in Fig. (3) and running water at 5 to 40°C, measure the flow rate with a pressure difference of 0.075 MPa. However, the pressure difference needs to be set with a large enough difference so that the Reynolds number does not go below a range of 4×10^4 .

By substituting the measurement results for formula (8) to figure out Av .

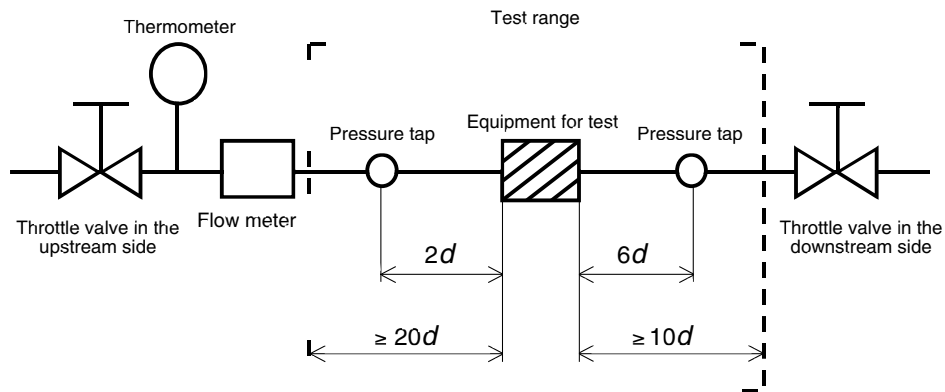
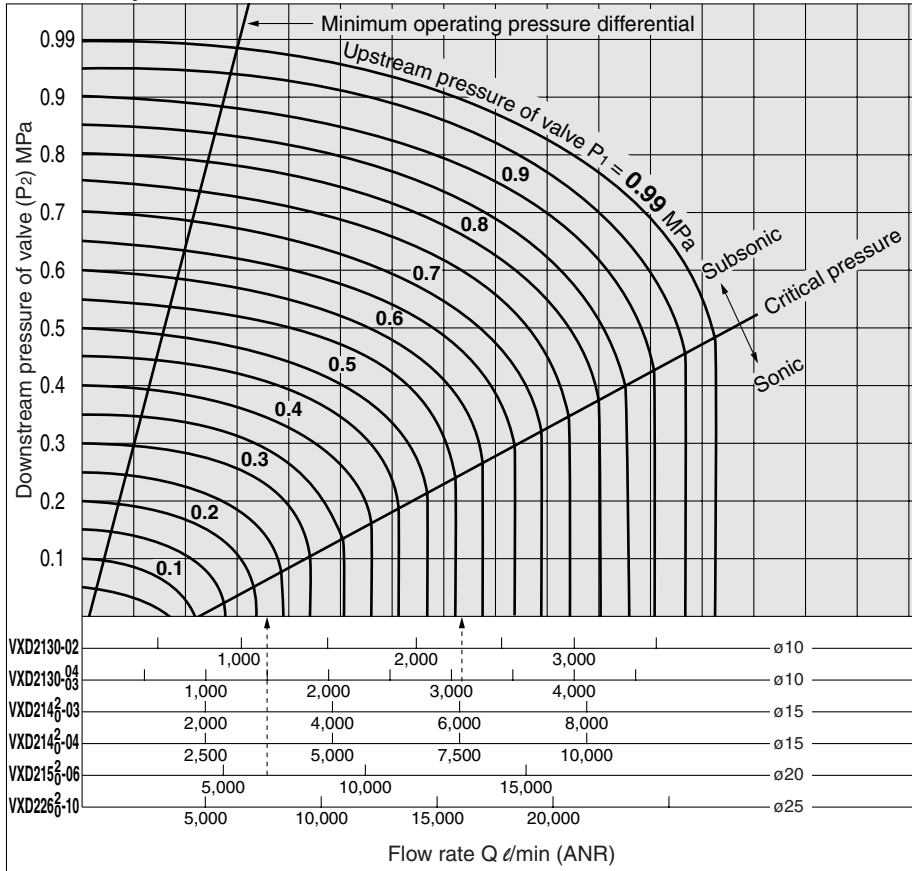

Fig. (3) Test circuit based on IEC60534-2-3, JIS B 2005

Flow Characteristics

Note) Use this graph as a guide. In the case of obtaining an accurate flow rate, refer to front matter pages 1 to 6.

For Air (Orifice size: $\phi 10$ mm, $\phi 15$ mm, $\phi 20$ mm, $\phi 25$ mm)



How to read the graph

The sonic range pressure to generate a flow rate of 6000 ℓ /min (ANR) is
 $P_1 \approx 0.57$ MPa for a $\phi 15$ orifice (VXD214⁰-03) and
 $P_1 \approx 0.22$ MPa for a $\phi 20$ orifice (VXD215⁰-06).

For Air (Orifice size: $\phi 35$ mm, $\phi 40$ mm, $\phi 50$ mm)

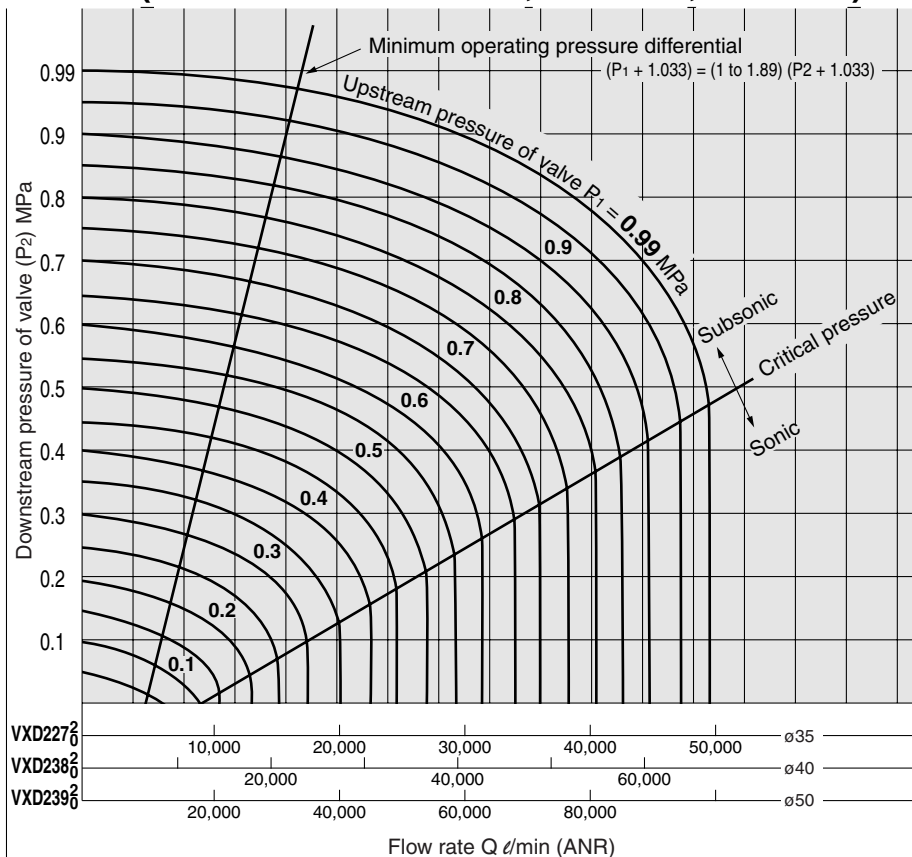

Flow Characteristics

For Water

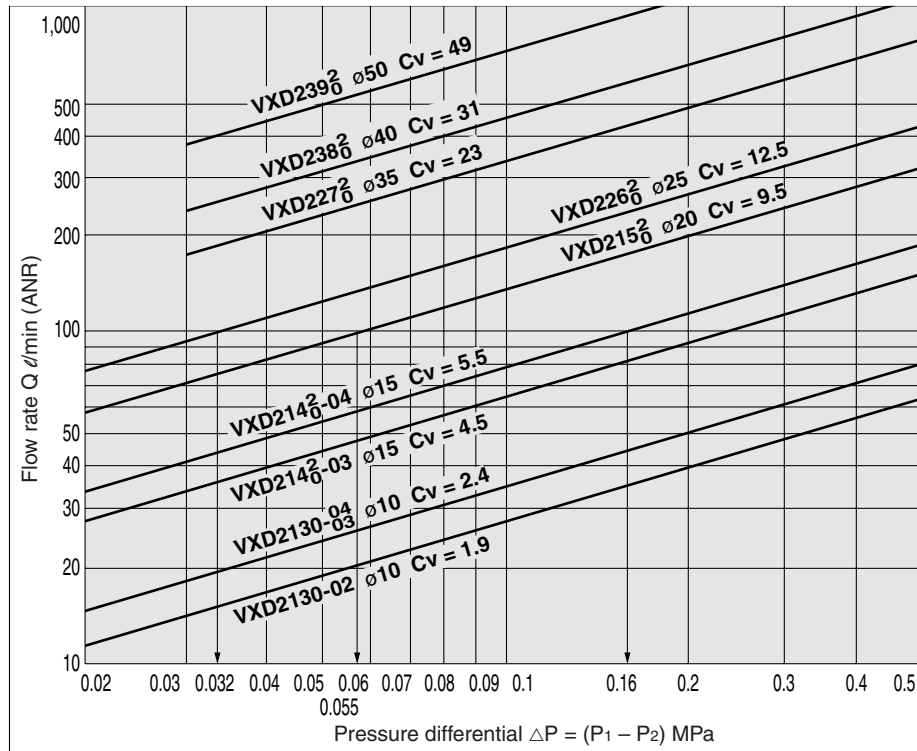

How to read the graph

When a water flow of 100 ℓ /min is generated,
 $\Delta P \approx 0.16$ MPa for a $\phi 15$ orifice (VXD2146²-04),
 $\Delta P \approx 0.055$ MPa for a $\phi 20$ orifice (VXD2156²), and
 $\Delta P \approx 0.032$ MPa for a $\phi 25$ orifice (VXD2266²).

Applicable Fluid Check List

Pilot Operated 2 Port Solenoid Valve Series VXD21/22/23



Normally closed (N.C.)

Option Symbol and Components

Option symbol	Seal material	Material Body: Shading coil	Coil insulation type	Note
Standard type	NBR	Brass (C37) or CAC407/Cu <small>Note 1)</small>	B	—
A	FKM			
B	EPDM		H	
D	FKM			
E	EPDM	Stainless steel/Ag <small>Note 3)</small>	B	— High corrosion resistance, Oil-free
G	NBR			
H	FKM			
J	EPDM		H	
L	FKM			
N	FKM			
P	EPDM			

Fluid Name and Option

Fluid (Application)	Option symbol and body material	
	Brass (C37) or CAC407 <small>Note 1)</small>	Stainless steel <small>Note 3)</small>
Applicable valve	10A to 50A	10A to 25A
Caustic soda (25% ≥)	—	J
Gas oil	A	H
Silicon oil	A	H
Steam system (Water for boiler)	—	G, J
Steam system (Condensation)	E	P
Perchloroethylene	A	H
Water (Max. 99°C)	D, E	N, P

Note 1) 10A to 25A are C37 and 32A to 50A are CAC407.

Note 2) The highest operating temperature of 32A to 50A is 80°C.

Note 3) Stainless steel/Ag is not available for valve sizes from 32A to 50A.

Note 4) Consult with SMC for other than above fluids.

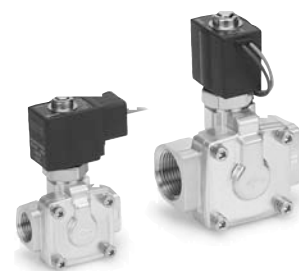

Normally open (N.O.)

Option Symbol and Components

Option symbol	Seal material	Material		Coil insulation type	Note
		Body: Shading coil	Inside bushing rod assembly		
Standard type	NBR	Brass (C37) or CAC407/Cu <small>Note 1)</small>	PPS	B	—
A	FKM				
B	EPDM		Stainless steel	H	
D	FKM				
E	EPDM	Stainless steel/Ag <small>Note 3)</small>	PPS	B	— High corrosion resistance, Oil-free
G	NBR				
H	FKM				
J	EPDM		Stainless steel	H	
L	FKM				
N	FKM				
P	EPDM				

Fluid Name and Option

Fluid (Application)	Option symbol and body material	
	Brass (C37) or CAC407 <small>Note 1)</small>	Stainless steel <small>Note 3)</small>
Applicable valve	15A to 50A	15A to 25A
Caustic soda (25% ≥)	—	J
Gas oil	A	H
Silicon oil	A	H
Steam system (Water for boiler)	—	G, J
Steam system (Condensation)	E	P
Perchloroethylene	A	H
Water (Max. 99°C)	E	N, P

Note 1) 10A to 25A are C37 and 32A to 50A are CAC407.

Note 2) The highest operating temperature of 32A to 50A is 80°C.

Note 3) Stainless steel/Ag is not available for valve sizes from 32A to 50A.

Note 4) Consult with SMC for other than above fluids.

Glossary of Terms

Pressure Terminology

1 Maximum operating pressure differential

The maximum pressure differential (the difference between the inlet and outlet pressure) which is allowed for operation, with the valve closed. When the downstream pressure is 0 MPa, this becomes the maximum operating pressure.

2 Minimum operating pressure differential

The minimum pressure differential (differential between the inlet pressure and the outlet pressure) required to keep the main valve fully opened.

Note) If the pressure differential is the minimum operating pressure differential when the valve is closed, it may be below the minimum operating pressure differential when the valve is open.

3 Maximum system pressure

The maximum pressure that can be applied inside the pipelines (line pressure).

(The pressure differential of the solenoid valve unit must be less than the maximum operating pressure differential.)

4. Proof pressure

The pressure which must be withstood without a drop in performance after returning to the operating pressure range. (value under the prescribed conditions)

Electrical Terminology

1 Apparent power (VA)

Volt-ampere is the product of voltage (V) and current (A). Power dissipation (W): For AC, $W = V \cdot A \cdot \cos\theta$. For DC, $W = V \cdot A$.

(Note) $\cos\theta$ shows power factor. $\cos\theta = 0.6$

2 Surge voltage

A high voltage which is momentarily generated in the shut-off unit by shutting off the power

3 Degree of protection

A degree defined in the "JIS C 0920: Waterproof test of electric machinery/appliance and the degree of protection against the intrusion of solid foreign objects"

IP65: Dusttight, Low jetproof type

"Low jetproof type" means that no water intrudes inside an equipment that could hinder from operating normally by means of discharging water for 3 minutes in the prescribed manner. Take appropriate protection measures, since a device is not usable in an environment where a water drop is splashed.

Others

1 Material

NBR: Nitrile rubber

FKM: Fluoro rubber Trade names: Viton® Dai-el® etc.

EPDM: Ethylene propylene rubber

PTFE: Polytetrafluoroethylene resin Trade names: Teflon® Polyflon®, etc.

FFKM: Perfluoroelastomer

Trade names: Kalrez®, Chemraz®

2. Oil-free treatment

The degreasing and washing of wetted parts.

3. Passage symbol

In the JIS symbol (□□□□) IN and OUT are in a blocked condition ($\frac{+}{-}$), but actually in the case of reverse pressure (OUT>IN), there is a limit to the blocking.

(ϕ) is used to indicate that blocking of reverse pressure is not possible.

Pilot Operated 2 Port Solenoid Valve

Series VXD21/22/23

For Water, Oil, Air

Single Unit

<p>Valve</p> <p>Normally closed (N.C.) Normally open (N.O.)</p>	<p>Electrical Entry</p> <p>• Grommet • DIN terminal • Conduit • Conduit terminal</p>		<table border="1"> <thead> <tr> <th>Model</th> <th>VXD2130</th> <th>VXD214$\frac{1}{2}$</th> <th>VXD215$\frac{3}{4}$</th> <th>VXD226$\frac{3}{4}$</th> </tr> </thead> <tbody> <tr> <td rowspan="4">Body size</td> <td>10A</td> <td>●</td> <td>—</td> <td>—</td> </tr> <tr> <td>15A</td> <td>—</td> <td>●</td> <td>—</td> </tr> <tr> <td>20A</td> <td>—</td> <td>—</td> <td>●</td> </tr> <tr> <td>25A</td> <td>—</td> <td>—</td> <td>●</td> </tr> <tr> <td>Port size (Thread)</td> <td>1/4, 3/8, 1/2</td> <td>3/8, 1/2</td> <td>3/4</td> <td>1</td> </tr> </tbody> </table>	Model	VXD2130	VXD214 $\frac{1}{2}$	VXD215 $\frac{3}{4}$	VXD226 $\frac{3}{4}$	Body size	10A	●	—	—	15A	—	●	—	20A	—	—	●	25A	—	—	●	Port size (Thread)	1/4, 3/8, 1/2	3/8, 1/2	3/4	1
Model	VXD2130		VXD214 $\frac{1}{2}$	VXD215 $\frac{3}{4}$	VXD226 $\frac{3}{4}$																									
Body size	10A	●	—	—																										
	15A	—	●	—																										
	20A	—	—	●																										
	25A	—	—	●																										
Port size (Thread)	1/4, 3/8, 1/2	3/8, 1/2	3/4	1																										
<p>Solenoid Coil</p> <p>Coil: Class B, Class H</p>	<p>Rated Voltage</p> <p>100 VAC, 200 VAC, 110 VAC, 220 VAC, 240 VAC, 230 VAC, 48 VAC, 24 VDC, 12 VDC</p>	<table border="1"> <thead> <tr> <th>Model</th> <th>VXD227$\frac{3}{4}$</th> <th>VXD238$\frac{3}{4}$</th> <th>VXD239$\frac{3}{4}$</th> </tr> </thead> <tbody> <tr> <td rowspan="3">Body size</td> <td>32A</td> <td>●</td> <td>—</td> </tr> <tr> <td>40A</td> <td>—</td> <td>●</td> </tr> <tr> <td>50A</td> <td>—</td> <td>●</td> </tr> <tr> <td>Port size (Flange)</td> <td>32A</td> <td>40A</td> <td>50A</td> </tr> </tbody> </table>	Model	VXD227 $\frac{3}{4}$	VXD238 $\frac{3}{4}$	VXD239 $\frac{3}{4}$	Body size	32A	●	—	40A	—	●	50A	—	●	Port size (Flange)	32A	40A	50A										
Model	VXD227 $\frac{3}{4}$	VXD238 $\frac{3}{4}$	VXD239 $\frac{3}{4}$																											
Body size	32A	●	—																											
	40A	—	●																											
	50A	—	●																											
Port size (Flange)	32A	40A	50A																											
<p>Material</p> <table border="1"> <tr> <td>Body</td> <td>Brass (C37)/CAC407, Stainless steel</td> </tr> <tr> <td>Seal</td> <td>NBR, FKM, EPDM</td> </tr> </table>	Body	Brass (C37)/CAC407, Stainless steel	Seal	NBR, FKM, EPDM																										
Body	Brass (C37)/CAC407, Stainless steel																													
Seal	NBR, FKM, EPDM																													

Standard Specifications

Valve specifications	Valve construction		Pilot operated 2 port diaphragm type	
	Withstand pressure (MPa)		5.0	
	Body material		Brass (C37), Stainless steel, CAC407	
	Seal material		NBR, FKM, EPDM	
	Enclosure		Dusttight, Low jetproof (equivalent to IP65) ^{Note 1)}	
Environment		Location without corrosive or explosive gases		
Coil specifications	Rated voltage	AC (Class B coil, with a full-wave rectifier)	100 VAC, 200 VAC, 110 VAC, 220 VAC, 230 VAC, 240 VAC, 48 VAC	
		AC (Class B coil/H coil) ^{Note 2)}		
		DC (Class B coil only)		24 VDC, 12 VDC
	Allowable voltage fluctuation			±10% of rated voltage
	Allowable leakage voltage	AC (Class B coil, with a full-wave rectifier)		±10% or less of rated voltage
		AC (Class B coil/H coil) ^{Note 2)}		±20% or less of rated voltage
DC (Class B coil only)		±2% or less of rated voltage		
Coil insulation type		Class B, Class H		

Note 1) Electrical entry, Grommet with surge voltage suppressor (GS) has a rating of IP40.

Note 2) The AC (Class B) coil for the VXD2130 comes with a full-wave rectifier.

Solenoid Coil Specifications

Note) The values are for an ambient temperature of 20°C and at the rated voltage.

DC Specification

Model	Power consumption (W)	Temperature rise (C°) ^{Note)}
VXD2130	5.5	50
VXD214 $\frac{1}{2}$ /215 $\frac{3}{4}$	4.5	45
VXD226 $\frac{3}{4}$ /227 $\frac{3}{4}$	7	45
VXD238 $\frac{3}{4}$ /239 $\frac{3}{4}$	10.5	60

AC Specification (Class B coil)

Model	Frequency (Hz)	Apparent power (VA)		Temperature rise (C°) ^{Note)}
		Inrush	Energized	
VXD21	50	19	9	45
	60	16	7	40
VXD22	50	43	19	55
	60	35	16	50
VXD23	50	62	30	65
	60	52	25	60

* The AC (Class B) coil for the VXD2130 comes with a full wave rectifier.

AC Specification (Class B coil, with a full-wave rectifier)

Model	Apparent power (VA)*	Temperature rise (C°) ^{Note)}
VXD21	7	55
VXD22	9.5	60
VXD23	12	65

* There is no difference in apparent power due to the inrush, energization, or frequency of the power, since the AC coil uses a rectifying circuit.

AC Specification (Class H coil)

Model	Frequency (Hz)	Apparent power (VA)		Temperature rise (C°) ^{Note)}
		Inrush	Energized	
VXD21	50	19	9	45
	60	16	7	40
VXD22	50	43	19	55
	60	35	16	50
VXD23	50	62	30	65
	60	52	25	60

How to Order Solenoid Coil Assembly

Table (1) Model and Solenoid Coil Type

Select the coil type from A to C, and refer to "How to Order" below.

Voltage type	AC		AC (with a full-wave rectifier)	DC
	Class B	Class H	Class B	Class H
(Solenoid valve option)	(Nil, A, B, G, H, J, L)	(D, E, N, P)	(Nil, A, B, G, H, J, L)	(Nil, A, B, G, H, J, L)
Model	VXD2130	— Note)	A	C
	VXD21 ⁴ ₅ □	A	A	C
	VXD22 ⁶ ₇ □	A	A	C
	VXD23 ⁸ ₉ □	A	A	C

DC, AC (Except VXD2130 AC/Class B) ^{Note 1)}

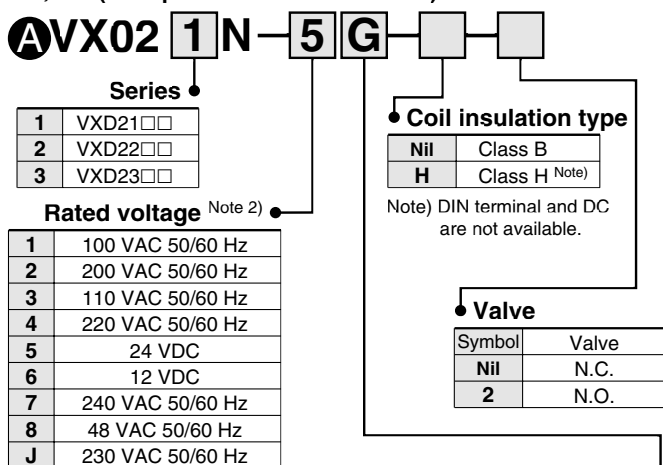

Note 1) The AC (Class B) coil for VXD2130 comes with a full-wave rectifier.

Note 2) Refer to "Table (2)" for the available combinations.

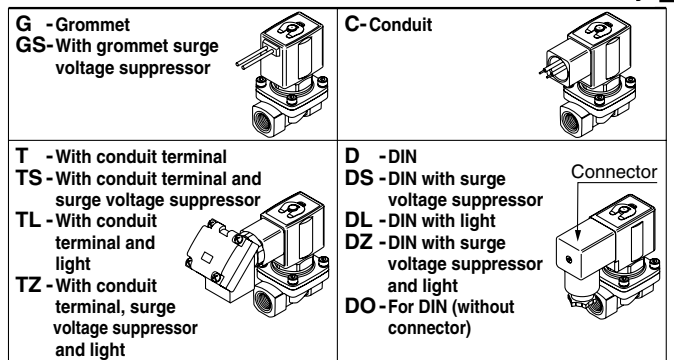

* Refer to "Table (2)" for the available combinations between each electrical option and rated voltage.

BVX021N-5G-Z

Rated voltage	
5	24 VDC
6	12 VDC

Table (2) Rated Voltage Electrical Option

Rated voltage	Class B			Class H			
	S	L	Z	S	L	Z	
AC/DC	With surge voltage suppressor	With light	With light and surge voltage suppressor	With surge voltage suppressor	With light	With light and surge voltage suppressor	
AC	1	100 V	●	●	●	●	
	2	200 V	●	●	●	●	
	3	110 V	●	●	●	●	
	4	220 V	●	●	●	●	
	7	240 V	●	—	—	●	—
	8	48 V	●	—	—	●	—
DC	J	230 V	●	—	—	—	
	5	24 V	●	●	●	DC specification is not available.	
6	12 V	●	—	—	—	—	

* Option S, Z are not available since a surge voltage suppressor is integrated into the AC/Class B coil, as a standard.

* When changing coils, AC/DC are not interchangeable with each other, and Class B and H coils are also not interchangeable with each other.

AC (with a full-wave rectifier)/DC are interchangeable with each other.

AC/Class B (with a full-wave rectifier)

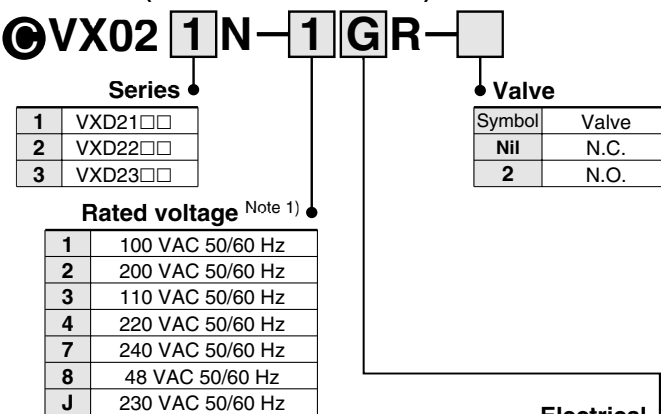

Note 1) Refer to "Table (2)" for the available combinations.

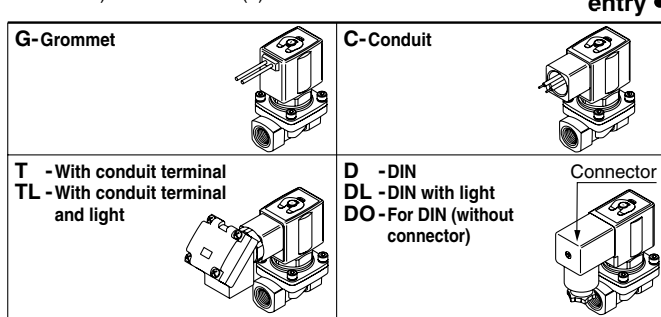

* Refer to "Table (2)" for the available combinations between each electrical option and rated voltage.

* A surge voltage suppressor is integrated into the AC/Class B coil, as a standard

• Name plate part no.

AZ-T-VX **Valve model**

↑ Enter by referring to "How to Order"

• Clip part no. (For N.C.)

For VXD21 VX021N-10
For VXD22: VX022N-10
For VXD23: VX023N-10

• Clip part no. (For N.O.)

For VXD21 ETW-7
For VXD22: ETW-8
For VXD23: ETW-9

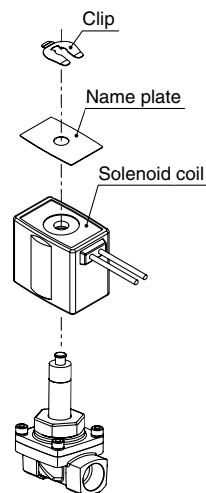

Series VXD21/22/23

For Water

Model/Valve Specifications

Normally closed (N.C.)

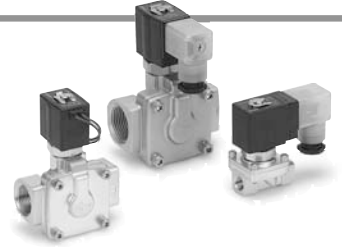
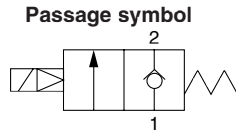

Port size	Orifice size (mmø)	Model	Min. operating pressure differential (MPa)	Max. operating pressure differential (MPa)		Flow characteristics		Max. system pressure (MPa)	Weight (g) ^{Note)}	
				AC	DC	Av x 10 ⁻⁶ m ²	Cv converted			
Thread	1/4 (8A)	10	VXD2130-02	0.02	0.7	0.5	46	1.9	1.5	420
	3/8 (10A)	10	VXD2130-03				58	2.4		
		15	VXD2140-03		110	4.5				
	1/2 (15A)	10	VXD2130-04		0.7	0.5	58	2.4		
		15	VXD2140-04		130	5.5				
	3/4 (20A)	20	VXD2150-06		230	9.5				
Flange	1 (25A)	25	VXD2260-10	1.0	1.0	310	13	1650		
	32A	35	VXD2270-32			550	23	5400		
	40A	40	VXD2380-40			740	31	6800		
	50A	50	VXD2390-50			1200	49	8400		

Note) Weight of grommet type. Add 10 g for conduit, 30 g for DIN terminal, and 60 g for terminal type respectively.
 • Refer to "Glossary of Terms" on front matter 10, for details on the max. operating pressure differential and the max. system pressure.

Normally open (N.O.)

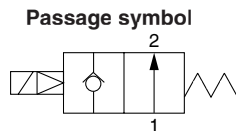

Port size	Orifice size (mmø)	Model	Min. operating pressure differential (MPa)	Max. operating pressure differential (MPa)		Flow characteristics		Max. system pressure (MPa)	Weight (g) ^{Note)}	
				AC, DC		Av x 10 ⁻⁶ m ²	Cv converted			
Thread	3/8 (10A)	15	VXD2142-03	0.7		110	4.5	1.5	690	
	1/2 (15A)	20	VXD2142-04			130	5.5			
	3/4 (20A)	25	VXD2152-06			230	9.5			
	1 (25A)	35	VXD2262-10			310	13			
Flange	32A	40	VXD2272-32	0.03		550	23	1.5	5400	
	40A	50	VXD2382-40			740	31			6800
	50A		VXD2392-50			1200	49			8400

Note) Weight of grommet type. Add 10 g for conduit, 30 g for DIN terminal, and 60 g for terminal type respectively.
 • Refer to "Glossary of Terms" on front matter 10, for details on the max. operating pressure differential and the max. system pressure.

Operating Fluid and Ambient Temperature

Power source	Operating fluid temperature (°C)		Ambient temperature (°C)
	Solenoid valve option		
	Nil, G, H	E, P	
AC	1 to 60	1 to 99	-10 to 60
DC	1 to 40	—	-10 to 40

Note 1) Since the AC/Class B coil (with a full-wave rectifier) uses a rectifying circuit, the fluid and ambient temperature are the same as the DC specifications.

Note 2) With no freezing

Tightness of Valve (Leakage Rate)

Seal material	Leakage rate (With water pressure)	
	1/4 to 1	32A to 50A
NBR, FKM, EPDM	0.2 cm ³ /min or less	1 cm ³ /min or less

How to Order

DC/AC (except VXD2130 AC/Class B)
AC/Class B coil (with a full-wave rectifier)

Model • Refer to "Table (1)" shown below for availability

Valve/Body configuration • Refer to "Table (1)" shown below for availability

Solenoid valve option • Refer to "Table (2)" shown below for availability.

Suffix •

Thread type • Refer to "Table (1)" shown below for availability

Rated voltage •

Orifice size • Refer to "Table (1)" shown below for availability

Port size • Refer to "Table (1)" shown below for availability

Electrical entry •

Bracket

With a full-wave rectifier, surge voltage suppressor

Electrical entry options:
G - Grommet
GS - With grommet surge voltage suppressor
C - Conduit
T - With conduit terminal
TS - With conduit terminal and surge voltage suppressor
TL - With conduit terminal and light
TZ - With conduit terminal, surge voltage suppressor and light
D - DIN
DS - DIN with surge voltage suppressor
DL - DIN with light
DZ - DIN with surge voltage suppressor and light
DO - For DIN (without connector)
 * DIN type is available with class B insulation only.

Bracket options:
Nil - None
B - With bracket
 * Bracket is not removable

Thread type options:
Nil - Rc
T - NPTF
F - G
N - NPT

Rated voltage options:
1 - 100 VAC 50/60 Hz
2 - 200 VAC 50/60 Hz
3 - 110 VAC 50/60 Hz
4 - 220 VAC 50/60 Hz
5 - 24 VDC
6 - 12 VDC
7 - 240 VAC 50/60 Hz
8 - 48 VAC 50/60 Hz
J - 230 VAC 50/60 Hz

Suffix options:
Nil - —
Z - Oil-free

* Refer to "Table (3)" shown below for availability.

Refer to page 1 for ordering coil only.

Table (1) Port/Orifice Size

Normally closed (N.C.)

Solenoid valve (Port size)				Orifice symbol							Material	
Model	VXD21	VXD22	VXD23	3 (10 mmø)	4 (15 mmø)	5 (20 mmø)	6 (25 mmø)	7 (35 mmø)	8 (40 mmø)	9 (50 mmø)	Body	Seal
Port no. (Port size)	Thread	02 (1/4)	—	—	●	—	—	—	—	—	Brass (C37), Stainless steel	NBR FKM EPDM
		03 (3/8)	—	—	●	●	—	—	—	—		
		04 (1/2)	—	—	●	●	—	—	—	—		
	06 (3/4)	—	—	—	—	●	—	—	—			
	—	10 (1)	—	—	—	—	●	—	—			
	—	32 (32A)	—	—	—	—	—	●	—			
Flange	—	—	40 (40A)	—	—	—	—	—	●	—	CAC407	
	—	—	50 (50A)	—	—	—	—	—	—	●		
	—	—	—	—	—	—	—	—	—	●		

Normally open (N.O.)

Solenoid valve (Port size)				Orifice symbol						Material	
Model	VXD21	VXD22	VXD23	4 (15 mmø)	5 (20 mmø)	6 (25 mmø)	7 (35 mmø)	8 (40 mmø)	9 (50 mmø)	Body	Seal
Port no. (Port size)	Thread	03 (3/8)	—	—	●	—	—	—	—	Brass (C37), Stainless steel	NBR FKM EPDM
		04 (1/2)	—	—	●	—	—	—	—		
		06 (3/4)	—	—	—	●	—	—	—		
	—	10 (1)	—	—	—	●	—	—	—		
	—	32 (32A)	—	—	—	—	●	—	—		
	—	—	40 (40A)	—	—	—	—	●	—		
Flange	—	—	50 (50A)	—	—	—	—	—	●	CAC407	
	—	—	—	—	—	—	—	—	●		

Table (2) Solenoid Valve Option

Option symbol	Seal material	Body material/ Shading coil material	Coil insulation type	Note
Nil	NBR	Brass (C37), Cu	B	—
G		Stainless steel, Ag		
E	EPDM	Brass (C37), Cu	H	Heated water (AC only)
P		Stainless steel, Ag		
L	FKM	Stainless steel, Ag	B	High corrosion resistance specification, Oil-free

Table (3) Rated Voltage Electrical Option

Rated voltage			Class B			Class H		
AC/DC	Voltage symbol	Voltage	S With surge voltage suppressor	L With light	Z With light and surge voltage suppressor	S With surge voltage suppressor	L With light	Z With light and surge voltage suppressor
AC	1	100 V	●	●	●	●	●	●
	2	200 V	●	●	●	●	●	●
	3	110 V	●	●	●	●	●	●
	4	220 V	●	●	●	●	●	●
	7	240 V	●	—	—	●	—	—
	8	48 V	●	—	—	●	—	—
DC	J	230 V	●	—	—	●	—	—
	5	24 V	●	●	●	DC specification is not available.		
	6	12 V	●	—	—			

Note: Option S, Z are not available as surge voltage suppressor is integrated into the AC/Class E coil as a standard.

For Water
For Oil
For Air

Series VXD21/22/23

For Oil

Model/Valve Specifications

Normally closed (N.C.)

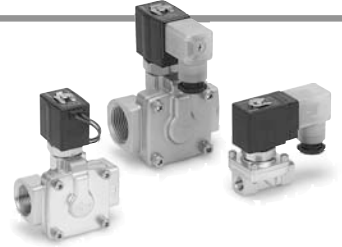
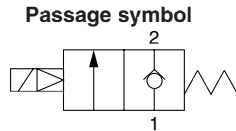

Port size	Orifice size (mmø)	Model	Min. operating pressure differential (MPa)	Max. operating pressure differential (MPa)		Flow characteristics		Max. system pressure (MPa)	Weight (g) ^{Note)}	
				AC	DC	Av x 10 ⁻⁶ m ²	Cv converted			
Thread	1/4 (8A)	10	VXD2130-02	0.02	0.5	0.4	46	1.9	1.5	420
	3/8 (10A)	10	VXD2130-03				58	2.4		
		15	VXD2140-03		110	4.5				
	1/2 (15A)	10	VXD2130-04		0.5	0.4	58	2.4		
		15	VXD2140-04		130	5.5				
	3/4 (20A)	20	VXD2150-06		230	9.5				
Flange	1 (25A)	25	VXD2260-10	0.7	0.7	310	13	1.5	1650	
	32A	35	VXD2270-32			550	23			
	40A	40	VXD2380-40			740	31			
	50A	50	VXD2390-50			1200	49			



Note) Weight of grommet type. Add 10 g for conduit, 30 g for DIN terminal, and 60 g for terminal type respectively.

• Refer to "Glossary of Terms" on front matter 10, for details on the max. operating pressure differential and the max. system pressure.

Normally open (N.O.)

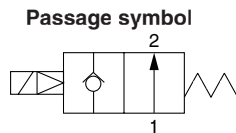

Port size	Orifice size (mmø)	Model	Min. operating pressure differential (MPa)	Max. operating pressure differential (MPa)		Flow characteristics		Max. system pressure (MPa)	Weight (g) ^{Note)}
				AC, DC		Av x 10 ⁻⁶ m ²	Cv converted		
Thread	3/8 (10A)	15	VXD2142-03	0.6		110	4.5	1.5	690
	1/2 (15A)		VXD2142-04			130	5.5		
	3/4 (20A)	20	VXD2152-06			230	9.5		
	1 (25A)	25	VXD2262-10			310	13		
Flange	32A	35	VXD2272-32	0.6		550	23	1.5	5400
	40A	40	VXD2382-40			740	31		
	50A	50	VXD2392-50			1200	49		



Note) Weight of grommet type. Add 10 g for conduit, 30 g for DIN terminal, and 60 g for terminal type respectively.

• Refer to "Glossary of Terms" on front matter 10, for details on the max. operating pressure differential and the max. system pressure.

Operating Fluid and Ambient Temperature

Power source	Operating fluid temperature (°C)		Ambient temperature (°C)
	Solenoid valve option		
	A, H	D, N	
AC	-5 to 60	-5 to 100	-10 to 60
DC	-5 to 40	—	-10 to 40

Note 1) Dynamic viscosity: 50 mm²/s or less

Note 2) Since the AC/Class B coil (with a full-wave rectifier) uses a rectifying circuit, the fluid and ambient temperature are the same as the DC specifications.

Tightness of Valve (Leakage Rate)

Seal material	Leakage rate (With oil pressure)	
	1/4 to 1	32A to 50A
FKM	0.2 cm ³ /min or less	1 cm ³ /min or less

How to Order

DC/AC (except VXD2130 AC/Class B)
AC/Class B coil (with a full-wave rectifier)

Model • Refer to "Table (1)" shown below for availability

Orifice size • Refer to "Table (1)" shown below for availability

Valve/Body configuration

0	N.C. / Single unit
2	N.O. / Single unit

Solenoid valve option • Refer to "Table (2)" shown below for availability.

Thread type

Nil	Rc
T	NPTF
F	G
N	NPT

Port size • Refer to "Table (1)" shown below for availability

Electrical entry

- G - Grommet
- GS - With grommet surge voltage suppressor
- C - Conduit
- T - With conduit terminal
- TS - With conduit terminal and surge voltage suppressor
- TL - With conduit terminal and light
- TZ - With conduit terminal, surge voltage suppressor and light
- D - DIN
- DS - DIN with surge voltage suppressor
- DL - DIN with light
- DZ - DIN with surge voltage suppressor and light
- DO - For DIN (without connector)

Bracket

Nil	None
B	With bracket

* Bracket is not removable

With a full-wave rectifier, surge voltage suppressor

Suffix

Nil	—
Z	Oil-free

Rated voltage

1	100 VAC 50/60 Hz	6	12 VDC
2	200 VAC 50/60 Hz	7	240 VAC 50/60 Hz
3	110 VAC 50/60 Hz	8	48 VAC 50/60 Hz
4	220 VAC 50/60 Hz	J	230 VAC 50/60 Hz
5	24 VDC		

* Refer to "Table (3)" shown below for availability.

Refer to page 1 for ordering coil only.

Table (1) Port/Orifice Size

Normally closed (N.C.)

Solenoid valve (Port size)				Orifice symbol							Material	
Model	VXD21	VXD22	VXD23	3 (10 mmø)	4 (15 mmø)	5 (20 mmø)	6 (25 mmø)	7 (35 mmø)	8 (40 mmø)	9 (50 mmø)	Body	Seal
Port no. (Port size)	Thread	02 (1/4)	—	—	●	—	—	—	—	—	Brass (C37), Stainless steel	NBR FKM EPDM
		03 (3/8)	—	—	●	●	—	—	—	—		
		04 (1/2)	—	—	●	●	—	—	—	—		
		06 (3/4)	—	—	—	—	●	—	—	—		
	Flange	—	10 (1)	—	—	—	—	●	—	—	CAC407	
		—	32 (32A)	—	—	—	—	—	●	—		
—	—	—	40 (40A)	—	—	—	—	—	●	—	—	
—	—	—	50 (50A)	—	—	—	—	—	—	●	—	

Normally open (N.O.)

Solenoid valve (Port size)				Orifice symbol						Material	
Model	VXD21	VXD22	VXD23	4 (15 mmø)	5 (20 mmø)	6 (25 mmø)	7 (35 mmø)	8 (40 mmø)	9 (50 mmø)	Body	Seal
Port no. (Port size)	Thread	03 (3/8)	—	—	●	—	—	—	—	Brass (C37), Stainless steel	NBR FKM EPDM
		04 (1/2)	—	—	●	—	—	—	—		
		06 (3/4)	—	—	—	●	—	—	—		
	Flange	—	10 (1)	—	—	—	●	—	—	CAC407	
		—	32 (32A)	—	—	—	●	—	—		
		—	—	40 (40A)	—	—	—	●	—		
—	—	—	50 (50A)	—	—	—	—	●	—		

Table (2) Solenoid Valve Option

Option symbol	Seal material	Body material/ Shading coil material	Coil insulation type
A	FKM	Brass (C37), Cu	B
H		Stainless steel, Ag	
D		Brass (C37), Cu	H
N		Stainless steel, Ag	

Table (3) Rated Voltage Electrical Option

Rated voltage			Class B			Class H		
AC/DC	Voltage symbol	Voltage	S With surge voltage suppressor	L With light	Z With light and surge voltage suppressor	S With surge voltage suppressor	L With light	Z With light and surge voltage suppressor
AC	1	100 V	●	●	●	●	●	●
	2	200 V	●	●	●	●	●	●
	3	110 V	●	●	●	●	●	●
	4	220 V	●	●	●	●	●	●
	7	240 V	●	—	—	●	—	—
	8	48 V	●	—	—	●	—	—
DC	J	230 V	●	—	—	●	—	—
	5	24 V	●	●	●	DC specification is not available.		
	6	12 V	●	—	—			

Note) Option S, Z are not available as surge voltage suppressor is integrated into the AC/Class B coil, as a standard.

Series VXD21/22/23

For Air

(Inert gas)

Model/Valve Specifications

Normally closed (N.C.)

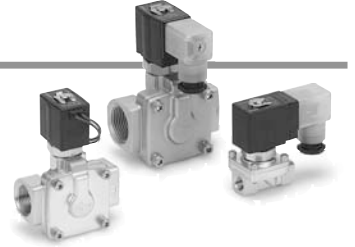
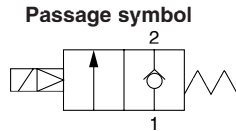

Port size	Orifice size (mmø)	Model	Min. operating pressure differential (MPa)	Max. operating pressure differential (MPa)		Flow characteristics			Max. system pressure (MPa)	Weight (g) ^{Note)}	
				AC	DC	C	b	Cv			
Thread	1/4 (8A)	10	VXD2130-02	0.02	0.9	0.7	8.5	0.35	2.0	1.5	420
	3/8 (10A)	10	VXD2130-03				9.2		2.4		
		15	VXD2140-03		18.0	5.0					
	1/2 (15A)	10	VXD2130-04		0.9	0.7	9.2		2.4		
		15	VXD2140-04		1.0	1.0	20.0		5.5		
	3/4 (20A)	20	VXD2150-06		1.0	1.0	38.0		0.30		

Port size	Orifice size (mmø)	Model	Min. operating pressure differential (MPa)	Max. operating pressure differential (MPa)		Flow characteristics		Max. system pressure (MPa)	Weight (g) ^{Note)}
				AC, DC	Effective area (mm ²)				
Thread	1 (25A)	25	VXD2260-10	0.02	1.0	225		1.5	1650
Flange	32A	35	VXD2270-32			0.03	415		5400
	40A	40	VXD2380-40	560			6800		
	50A	50	VXD2390-50	880			8400		



Note) Weight of grommet type. Add 10 g for conduit, 30 g for DIN terminal, and 60 g for terminal type respectively
 • Refer to "Glossary of Terms" on front matter 10, for details on the max. operating pressure differential and the max. system pressure.

Normally open (N.O.)

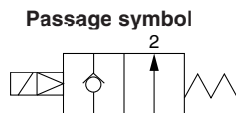

Port size	Orifice size (mmø)	Model	Min. operating pressure differential (MPa)	Max. operating pressure differential (MPa)		Flow characteristics			Max. system pressure (MPa)	Weight (g) ^{Note)}
				AC, DC	C	b	Cv			
Thread	3/8 (10A)	15	VXD2142-03	0.02	0.7	18.0	0.35	5.0	1.5	690
	1/2 (15A)	VXD2142-04	20.0			5.5				
	3/4 (20A)	20	VXD2152-06			38.0		0.30		

Port size	Orifice size (mmø)	Model	Min. operating pressure differential (MPa)	Max. operating pressure differential (MPa)		Flow characteristics		Max. system pressure (MPa)	Weight (g) ^{Note)}
				AC, DC	Effective area (mm ²)				
Thread	1 (25A)	25	VXD2262-10	0.02	0.7	225		1.5	1690
Flange	32A	35	VXD2272-32			0.03	415		5400
	40A	40	VXD2382-40	560			6800		
	50A	50	VXD2392-50	880			8400		



Note) Weight of grommet type. Add 10 g for conduit, 30 g for DIN terminal, and 60 g for terminal type respectively
 • Refer to "Glossary of Terms" on front matter 10, for details on the max. operating pressure differential and the max. system pressure.

Operating Fluid and Ambient Temperature

Power source	Operating fluid temperature (°C)		Ambient temperature (°C)
	Solenoid valve option		
	Nil, G		
AC	-10 ^{Note)} to 60		-10 to 60
DC	-10 to 60		-10 to 40

Note) Dew point temperature: -10°C or less

Tightness of Valve (Leakage Rate)

Seal material	Leakage rate (Air)	
	1/4 to 1	32A to 50A
NBR, FKM	2 cm ³ /min or less	10 cm ³ /min or less

How to Order (Single Unit)

DC VXD 21 3 0 [] [] 02 [] 5 G 1 []

AC/Class B coil (with a full-wave rectifier) VXD 21 3 0 [] [] 02 [] 1 G R1 []

* The AC (Class B) coil for VXD2130 comes with a full-wave rectifier.

Model • Refer to "Table (1)" shown below for availability

Orifice size • Refer to "Table (1)" shown below for availability

Valve/Body configuration •

0	N.C. / Single unit
2	N.O. / Single unit

Solenoid valve option • Refer to "Table (2)" shown below for availability.

Thread type • Refer to "Table (1)" shown below for availability

Nil	Rc
T	NPTF
F	G
N	NPT

Port size • Refer to "Table (1)" shown below for availability

Electrical entry •

- G - Grommet
- GS - With grommet surge voltage suppressor
- C - Conduit
- T - With conduit terminal
- TS - With conduit terminal and surge voltage suppressor
- TL - With conduit terminal and light
- TZ - With conduit terminal, surge voltage suppressor and light
- D - DIN
- DS - DIN with surge voltage suppressor
- DL - DIN with light
- DZ - DIN with surge voltage suppressor and light
- DO - For DIN (without connector)

* DIN type is available with class B insulation only.

Bracket

Nil	None
B	With bracket

* Bracket is not removable

With a full-wave rectifier, surge voltage suppressor

Suffix

Nil	—
Z	Oil-free

Rated voltage

1	100 VAC 50/60 Hz	6	12 VDC
2	200 VAC 50/60 Hz	7	240 VAC 50/60 Hz
3	110 VAC 50/60 Hz	8	48 VAC 50/60 Hz
4	220 VAC 50/60 Hz	J	230 VAC 50/60 Hz
5	24 VDC		

* Refer to "Table (3)" shown below for availability.

Refer to page 1 for ordering coil only.

Table (1) Port/Orifice Size

Normally closed (N.C.)

Solenoid valve (Port size)				Orifice symbol							Material		
Model	VXD21	VXD22	VXD23	3 (10 mmø)	4 (15 mmø)	5 (20 mmø)	6 (25 mmø)	7 (35 mmø)	8 (40 mmø)	9 (50 mmø)	Body	Seal	
Port no. (Port size)	Thread	02 (1/4)	—	—	●	—	—	—	—	—	Brass (C37), Stainless steel	NBR	
		03 (3/8)	—	—	●	●	—	—	—	—			
		04 (1/2)	—	—	●	●	—	—	—	—			
		06 (3/4)	—	—	—	—	●	—	—	—			
	Flange	—	10 (1)	—	—	—	—	●	—	—			CAC407
		—	32 (32A)	—	—	—	—	—	●	—			
—	—	—	40 (40A)	—	—	—	—	—	●	—	—		
—	—	—	50 (50A)	—	—	—	—	—	—	●	—		

Normally open (N.O.)

Solenoid valve (Port size)				Orifice symbol						Material		
Model	VXD21	VXD22	VXD23	4 (15 mmø)	5 (20 mmø)	6 (25 mmø)	7 (35 mmø)	8 (40 mmø)	9 (50 mmø)	Body	Seal	
Port no. (Port size)	Thread	03 (3/8)	—	—	●	—	—	—	—	Brass (C37), Stainless steel	NBR	
		04 (1/2)	—	—	●	—	—	—	—			
		06 (3/4)	—	—	—	●	—	—	—			
	Flange	—	10 (1)	—	—	—	●	—	—			CAC407
		—	32 (32A)	—	—	—	●	—	—			
		—	—	40 (40A)	—	—	—	●	—			
—	—	—	50 (50A)	—	—	—	—	●	—			

Table (2) Solenoid Valve Option

Option symbol	Seal material	Body material/ Shading coil material	Coil insulation type	Note
Nil	NBR	Brass (C37), Cu	B	—
G		Stainless steel, Ag		

Table (3) Rated Voltage Electrical Option

Rated voltage			Class B			Class H		
AC/DC	Voltage symbol	Voltage	S With surge voltage suppressor	L With light	Z With light and surge voltage suppressor	S With surge voltage suppressor	L With light	Z With light and surge voltage suppressor
AC	1	100 V	●	●	●	●	●	●
	2	200 V	●	●	●	●	●	●
	3	110 V	●	●	●	●	●	●
	4	220 V	●	●	●	●	●	●
	7	240 V	●	—	—	●	—	—
	8	48 V	●	—	—	●	—	—
DC	J	230 V	●	—	—	●	—	—
	5	24 V	●	●	●	DC specification is not available.		
	6	12 V	●	—	—	DC specification is not available.		

Note: Option S Z are not available as surge voltage suppressor is integrated into the AC/Class B coil as a standard

Series VXD21/22/23

Construction

Normally closed (N.C.)

Body material Brass (C37) (32A or more: CAC407), Stainless steel

VXD2130 (10A)

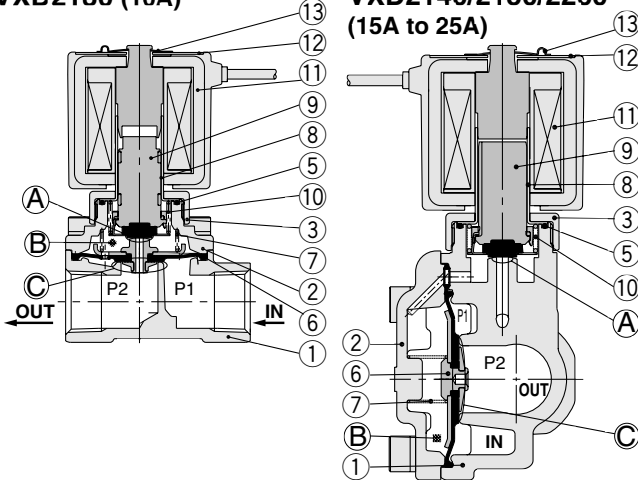

VXD2140/2150/2260 (15A to 25A)

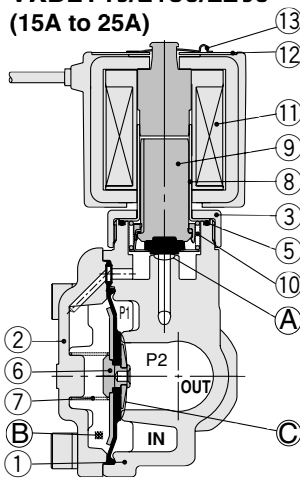

VXD2270/2380/2390 (32A to 50A)

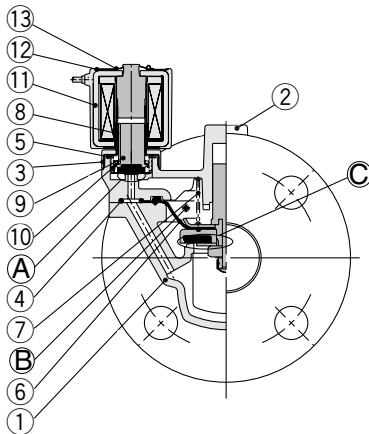

Operation

<Valve opened> When the coil (11) is energized, the armature assembly (9) is attracted into the core of the tube assembly (8) and the pilot valve (A) opens. Then the pressure in the pressure action chamber (B) falls to open the main valve (C).
<Valve closed> When the coil (11) is not energized, the pilot valve (A) is closed and the pressure in the pressure action chamber (B) rises and the main valve (C) closes.

Component Parts

No.	Description	Size	Material	
			Standard	Option
1	Body	10A to 25A	Brass (C37)	Stainless steel
		32A to 50A	CAC407	
2	Bonnet	10A to 25A	Brass (C37)	Stainless steel
		32A to 50A	CAC407	
3	Nut	10A to 50A	Brass (C37)	Brass (C37), Ni plated
4	O-ring	32A to 50A	NBR	FKM, EPDM
5	O-ring	10A to 50A	NBR	FKM, EPDM
6	Diaphragm assembly	10A to 25A	Stainless steel, NBR	Stainless steel, FKM, EPDM
		32A to 50A	Stainless steel, Brass (C37), NBR	Stainless steel, FKM, EPDM
7	Valve spring	10A to 50A	Stainless steel	
8	Tube assembly	10A to 25A	Stainless steel, Cu	Stainless steel, Ag
		32A to 50A		
9	Armature assembly	10A	Stainless steel, PPS, NBR	Stainless steel, PPS, FKM, EPDM
		15A to 50A		
10	Return spring	10A to 50A	Stainless steel	
11	Solenoid coil	10A to 50A	Class B molded	Class H molded
12	Name plate	10A to 50A	Aluminum	
13	Clip	10A to 50A	SK	

Normally open (N.O.)

Body material: Brass (C37) (32A or more: CAC407), Stainless steel

VXD2142/2152/2262 (15A to 25A)

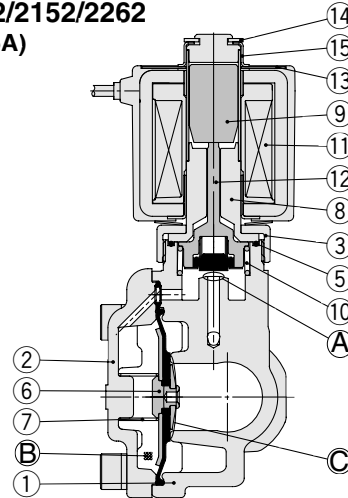

VXD2272/2382/2392 (32A to 50A)

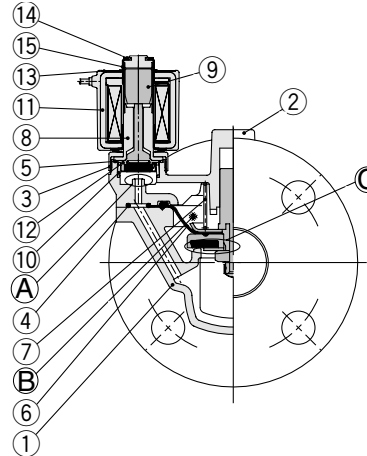

Operation

<Valve opened> When the coil (11) is energized, the opened pilot (A) closes, the pressure in pressure action chamber (B) rises and the main valve (C) closes.
<Valve closed> When the coil (11) is not energized, the closed pilot valve (A) opens, the pressure in pressure action chamber (B) drops and the main valve (C) opens.

Component Parts

No.	Description	Size	Material	
			Standard	Option
1	Body	15A to 25A	Brass (C37)	Stainless steel
		32A to 50A	CAC407	
2	Bonnet	15A to 25A	Brass (C37)	Stainless steel
		32A to 50A	CAC407	
3	Nut	15A to 25A	Brass (C37)	Brass (C37), Ni plated
4	O-ring	32A to 50A	NBR	FKM, EPDM
5	O-ring	15A to 50A	NBR	FKM, EPDM
6	Diaphragm assembly	15A to 25A	Stainless steel, NBR	Stainless steel, FKM, EPDM
		32A to 50A	Stainless steel, NBR	Stainless steel, FKM, EPDM
7	Valve spring	15A to 25A	Stainless steel	
8	Tube assembly	15A to 25A	Stainless steel, Cu	Stainless steel, Ag
		32A to 50A		
9	Armature assembly	10A to 50A	Stainless steel	
10	Return spring	15A to 50A	Stainless steel	
11	Solenoid coil	15A to 50A	Class B molded	Class H molded
12	Push rod assembly	15A to 50A	NBR, PPS, Stainless steel	FKM, EPDM, Stainless steel
13	Name plate	15A to 50A	Aluminum	
14	Clip	15A to 50A	SK	
15	Cover	15A to 50A	Stainless steel	

The materials in parentheses are the seal materials.

Dimensions

Normally closed (N.C.): VXD2130

Grommet: G

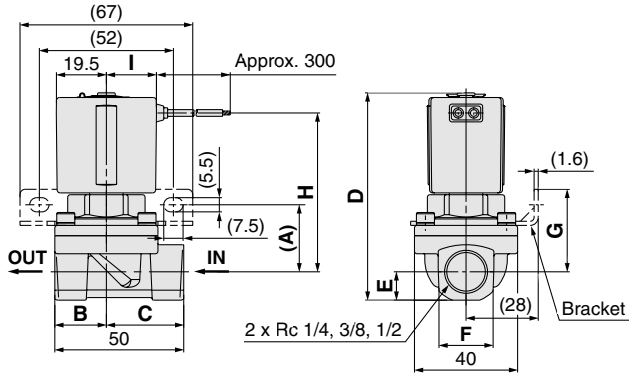

Conduit: C

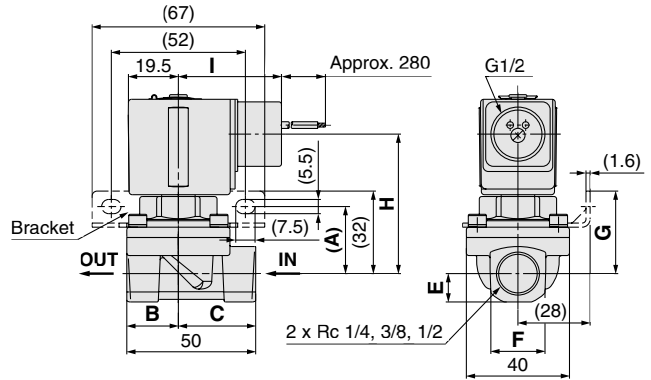

DIN terminal: D

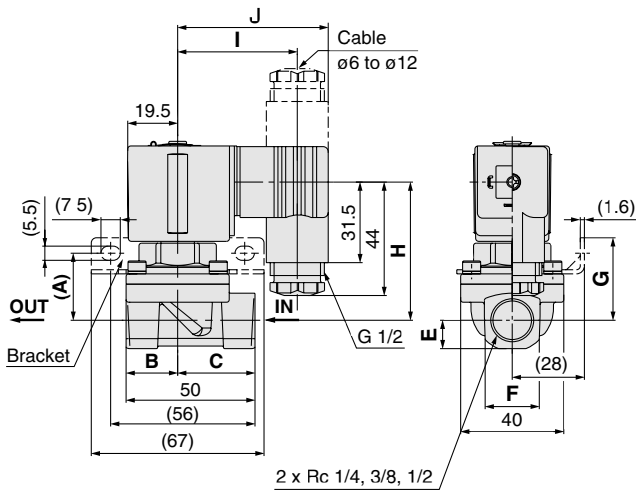

Conduit terminal: T

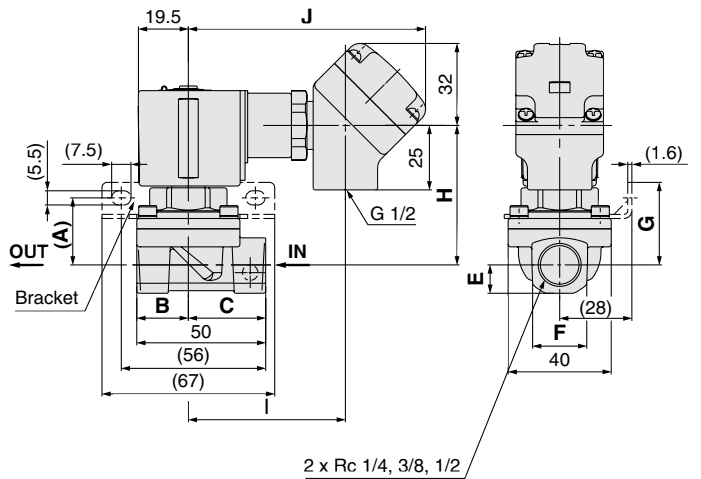

VXD2130-04

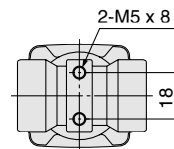

Model	Port size P	A	B	C	D	E	F	G	Electrical entry (DC, AC/Class H coil)									
									Grommet		Conduit		DIN terminal		Conduit terminal			
									H	I	H	I	H	I	J	H	I	J
Normally closed VXD2130	1/4, 3/8	26	20	30	80.5	11	21	32	62	19.5	54.5	40	54	46.5	58.5	54.5	61	92
	1/2	28	24	26	86	14.5	28	34	64	19.5	56.5	40	56	46.5	58.5	56.5	61	92

Model	Electrical entry (AC/Class B coil)*									
	Grommet		Conduit		DIN terminal		Conduit terminal			
	H	I	H	I	H	I	J	H	I	J
Normally closed VXD2130	58	30	53	48.5	54	53.5	65.5	53	69.5	100.5
	60	30	55	48.5	56	53.5	65.5	55	69.5	100.5

* Coil with a full-wave rectifier (electrical option "R")

Series VXD21/22/23

Dimensions

Normally closed (N.C.): VXD2140/2150/2260

Normally open (N.O.): VXD2142/2152/2262

Grommet: G

Conduit: C

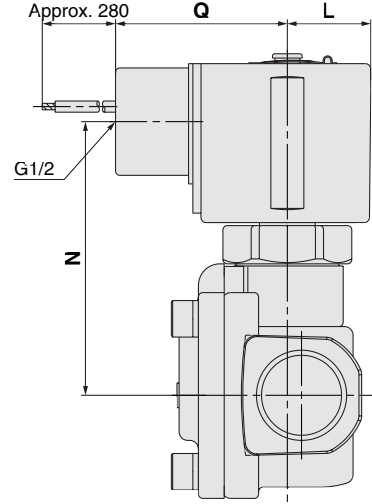
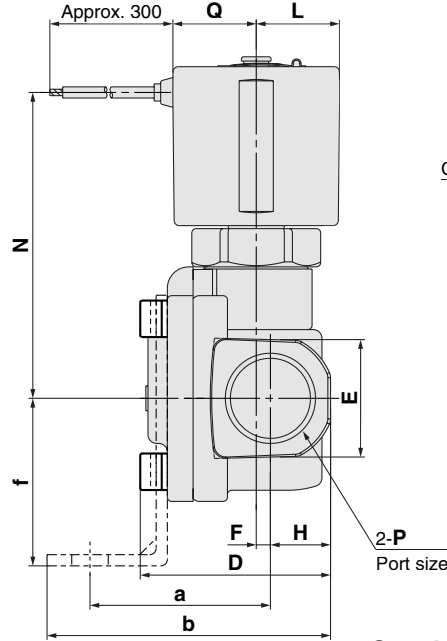
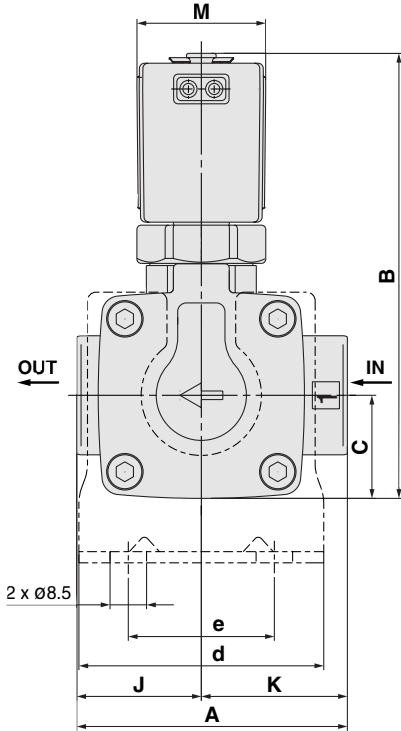

DIN terminal: D

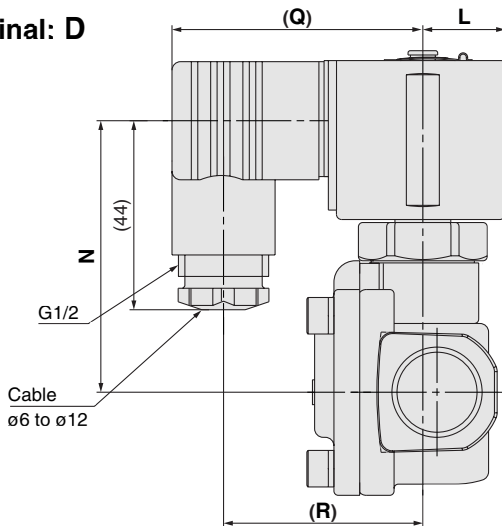

Conduit terminal: T

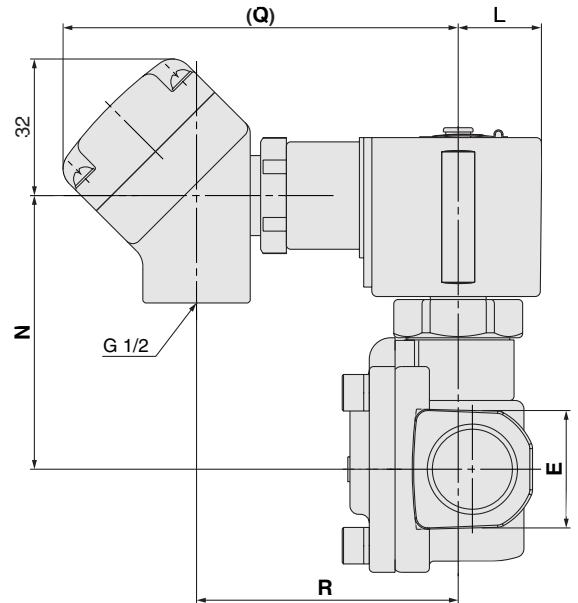

Model		Port size P	A	B	C	D	E	F	H	J	K	L	M	Electrical entry (DC, AC)											
Normally closed	Normally open	Rc												Grommet			Conduit			DIN terminal			Conduit terminal		
														N	Q	N	Q	N	Q	R	N	Q	R		
VXD2140	VXD2142	3/8, 1/2	63	104 (110.5)	24	44.5	28	3.5	14	29	34	19.5	30	71.5	19.5	64	40	63.5	58.5	46.5	64	92	61		
VXD2150	VXD2152	3/4	80	115.5 (122)	29	51.5	35	4.5	17	37	43	19.5	30	78	19.5	70.5	40	70	65.5	46.5	70.5	92	61		
VXD2260	VXD2262	1	90	133 (140.5)	33	60	42	4.5	20	43	47	22.5	35	92	22.5	84.5	43	84	61.5	49.5	84.5	95	64		

denotes the value for N O.

Model		Port size P	Bracket mounting					
Normally closed	Normally open	Rc	a	b	d	e	f	
VXD2140	VXD2142	3/8, 1/2	42	66	57	34	39	
VXD2150	VXD2152	3/4	46	73	74	51	45.5	
VXD2260	VXD2262	1	56	86	81	58	49.5	

Model		Electrical entry (AC/Class B coil)*											
Normally closed	Normally open	Grommet			Conduit			DIN terminal			Conduit terminal		
		N	Q	N	Q	N	Q	R	N	Q	R		
VXD2140	VXD2142	67.5	37	62.5	48.5	63.5	65.5	53.5	62.5	100.5	69.5		
VXD2150	VXD2152	74	37	69	48.5	70	65.5	53.5	69	100.5	69.5		
VXD2260	VXD2262	88	40	83	51.5	84	68.5	56.5	83	103.5	72.5		

* Coil with a full-wave rectifier (electrical option "R")

Dimensions

Normally closed (N.C.): VXD2270/2380/2390

Normally open (N.O.): VXD2272/2382/2392

Grommet: G

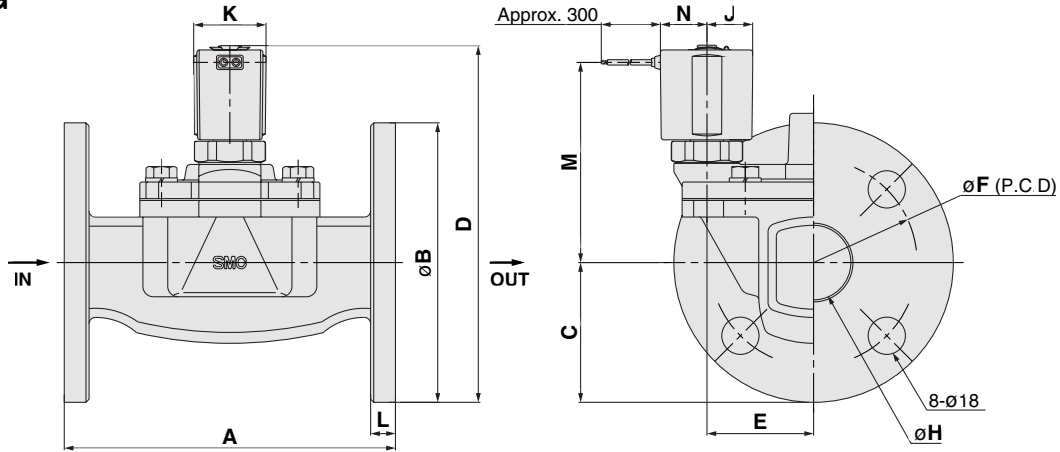

Conduit: C

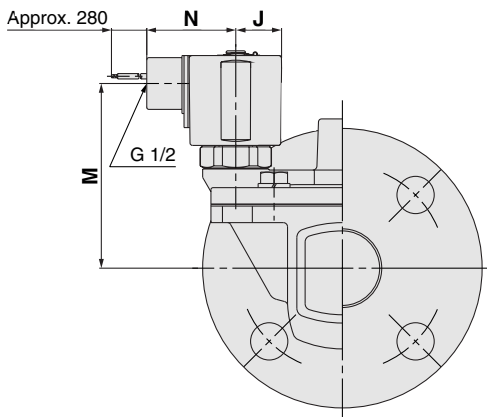

DIN terminal D

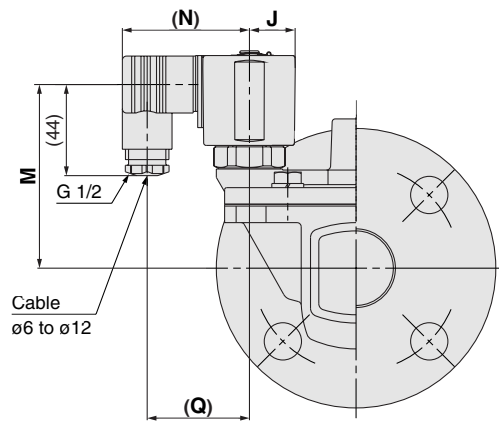

Conduit terminal T

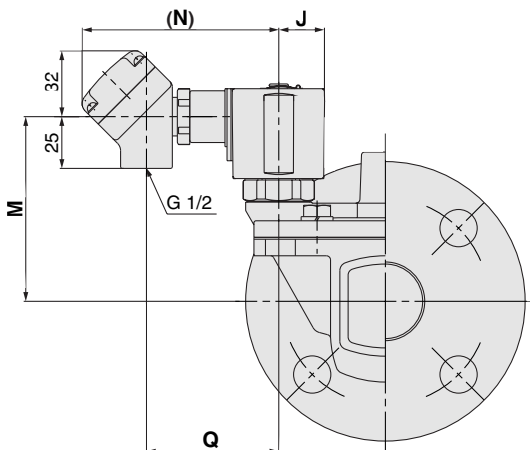

(mm)

Model		Electrical entry (AC/Class B coil)*									
		Grommet		Conduit		DIN terminal			Conduit terminal		
Normally closed	Normally open	M	N	M	N	M	N	Q	M	N	Q
VXD2270	VXD2272	93	33	88	51.5	89	68.5	56.5	88	103.5	72.5
VXD2380	VXD2382	103	36	98	54	99	71	59	98	106	75
VXD2390	VXD2392	108.5	36	103.5	54	104.5	71	59	103.5	106	75

) denotes the value for N.O

* Coil with a full-wave rectifier (electrical option "R")

(mm)

Model		Applicable flange	A	B	C	D	E	F	H	J	K	L	Electrical entry (DC, AC)									
													Grommet		Conduit		DIN terminal			Conduit terminal		
Normally closed	Normally open												M	N	M	N	Q	M	N	Q		
VXD2270	VXD2272	32A	160	135	67.5	172.5 (180)	51.5	100	36	22.5	35	12	97	22.5	89.5	43	89	61.5	49.5	89.5	95	64
VXD2380	VXD2382	40A	170	140	70	185 (192.5)	54.5	105	42	25	40	14	106.5	25.5	99	46	98.5	64	52	99	98	66.5
VXD2390	VXD2392	50A	180	155	77.5	198.5 (205.5)	59	120	52	25	40	14	112.5	25.5	105	46	104.5	64	52	105	98	66.5

) denotes the value for N.O.



Series VXD21/22/23

Safety Instructions

These safety instructions are intended to prevent a hazardous situation and/or equipment damage. These instructions indicate the level of potential hazard by labels of "Caution", "Warning" or "Danger". To ensure safety, be sure to observe ISO 4414 ^{Note 1)}, JIS B 8370 ^{Note 2)} and other safety practices.

⚠ Caution : Operator error could result in injury or equipment damage.

⚠ Warning : Operator error could result in serious injury or loss of life.

⚠ Danger : In extreme conditions, there is a possible result of serious injury or loss of life.

Note 1) ISO 4414: Pneumatic fluid power--General rules relating to systems.

Note 2) JIS B 8370: General Rules for Pneumatic Equipment

⚠ Warning

1. The compatibility of the pneumatic equipment is the responsibility of the person who designs the pneumatic system or decides its specifications.

Since the products specified here are used in various operating conditions, their compatibility for the specific pneumatic system must be based on specifications or post analysis and/or tests to meet your specific requirements. The expected performance and safety assurance are the responsibility of the person who has determined the compatibility of the system. This person should continuously review the suitability of all items specified, referring to the latest catalog information with a view to giving due consideration to any possibility of equipment failure when configuring a system.

2. Only trained personnel should operate pneumatically operated machinery and equipment.

Compressed air can be dangerous if handled incorrectly. Assembly, handling or repair of pneumatic systems should be performed by trained and experienced operators.

3. Do not service machinery/equipment or attempt to remove components until safety is confirmed.

1. Inspection and maintenance of machinery/equipment should only be performed once measures to prevent falling or runaway of the driven objects have been confirmed.
2. When equipment is removed, confirm that safety process as mentioned above. Turn off the supply pressure for this equipment and exhaust all residual compressed air in the system.
3. Before machinery/equipment is restarted, take measures to prevent quick extension of a cylinder piston rod, etc.

4. Contact SMC if the product will be used in any of the following conditions:

1. Conditions and environments beyond the given specifications, or if product is used outdoors.
2. Installation on equipment in conjunction with atomic energy, railway, air navigation, vehicles, medical equipment, food and beverages, recreation equipment, emergency stop circuits, clutch and brake circuits in press applications, or safety equipment.
3. An application which has the possibility of having negative effects on people, property, or animals, requiring special safety analysis.



2 Port Solenoid Valve for Fluid Control/Precautions 1

Be sure to read this before handling.

For detailed precautions on each series, refer to the main text.

Caution on Design

Warning

1. Cannot be used as an emergency shutoff valve, etc.

The valves presented in this catalog are not designed for safety applications such as an emergency shutoff valve. If the valves are used in this type of system, other reliable safety assurance measures should also be adopted.

2. Extended periods of continuous energization

The solenoid coil will generate heat when continuously energized. Avoid using in a tightly shut container. Install it in a well-ventilated area. Furthermore, do not touch it while it is being energized or right after it is energized.

3. This solenoid valve cannot be used for explosion proof applications.

4. Maintenance space

The installation should allow sufficient space for maintenance activities (removal of valve, etc.).

5. Liquid rings

In cases with a flowing liquid, provide a bypass valve in the system to prevent the liquid from entering the liquid seal circuit.

6. Actuator drive

When an actuator, such as a cylinder, is to be driven using a valve, take appropriate measures to prevent potential danger caused by actuator operation.

7. Pressure (including vacuum) holding

It is not usable for an application such as holding the pressure (including vacuum) inside of a pressure vessel because air leakage is entailed in a valve.

8. When the conduit type is used as equivalent to an IP65 enclosure, install a wiring conduit, etc.

9. When an impact, such as water hammer, etc., caused by the rapid pressure fluctuation is applied, the solenoid valve may be damaged. Give an attention to it.

Selection

Warning

1. Confirm the specifications.

Give careful consideration to the operating conditions such as the application, fluid and environment, and use within the operating ranges specified in this catalog.

2. Fluid

1) Type of fluid

Before using a fluid, confirm whether it is compatible with the materials from each model by referring to the fluids listed in this catalog. Use a fluid with a dynamic viscosity of 50 mm²/s or less. If there is something you do not know, please contact us.

2) Inflammable oil, Gas

Confirm the specification for leakage in the interior and/or exterior area.

Selection

Warning

3) Corrosive gas

Cannot be used since it will lead to cracks by stress corrosion or result in other incidents.

4) Use an oil-free specification when any oily particle must not enter the passage.

5) Applicable fluid on the list may not be used depending on the operating condition. Give adequate confirmation, and then determine a model, just because the compatibility list shows the general case.

3. Fluid quality

The use of a fluid which contains foreign matter can cause problems such as malfunction and seal failure by promoting wear of the valve seat and armature, and by sticking to the sliding parts of the armature, etc. Install a suitable filter (strainer) immediately upstream from the valve. As a general rule, use 80 to 100 mesh. When used to supply water to boilers, substances such as calcium and magnesium which generate hard scale and sludge are included. Since this scale and sludge can cause the valve to malfunction, install water softening equipment, and a filter (strainer) directly upstream from the valve to remove these substances.

4. Air quality

1) Use clean air.

Do not use compressed air which includes chemicals, synthetic oils containing organic solvents, salt or corrosive gases, etc., as it can cause damage or malfunction.

2) Install air filters.

Install air filters close to valves at their upstream side. A filtration degree of 5µm or less should be selected.

3) Install an air dryer or after cooler, etc.

Compressed air that includes excessive drainage may cause malfunction of valves and other pneumatic equipment. To prevent this, install an air dryer or after cooler, etc.

4) If excessive carbon powder is generated, eliminate it by installing mist separators at the upstream side of valves.

If excessive carbon powder is generated by the compressor, it may adhere to the inside of the valves and cause a malfunction.

Refer to SMC's Best Pneumatics catalog vol. 14 for further details on compressed air quality.

5. Ambient environment

Use within the operable ambient temperature range. Confirm the compatibility between the product's composition materials and the ambient atmosphere. Be sure that the fluid used does not touch the external surface of the product.

6. Countermeasures against static electricity

Take measures to prevent static electricity since some fluids can cause static electricity.

7. For the low particle generation specification, confirm us separately.



2 Port Solenoid Valve for Fluid Control/Precautions 2

Be sure to read this before handling.

For detailed precautions on each series, refer to the main text.

Selection

⚠ Caution

1. Leakage voltage

Particularly when using a resistor in parallel with a switching element and using a C-R element (surge voltage suppressor) to protect the switching element, take note that leakage current will flow through the resistor, C-R element, etc., creating a possible danger that the valve may not turn off.

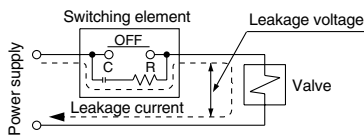

- AC/Class B coil with a full-wave rectifier: 10% or less of rated voltage
- AC/Class B, H coil: 20% or less of rated voltage
- DC coil: 2% or less of rated voltage

2. Low temperature operation

1. The valve can be used in an ambient temperature of between -10 to -20°C , however take measures to prevent freezing or solidification of impurities, etc.
2. When using valves for water application in cold climates, take appropriate countermeasures to prevent the water from freezing in tubing after cutting the water supply from the pump, by draining the water, etc. When heating by steam, be careful not to expose the coil portion to steam. Installation of dryer, heat retaining of the body is recommended to prevent a freezing condition in which the dew point temperature is high and the ambient temperature is low, and the high flow runs.

Mounting

⚠ Warning

1. If air leakage increases or equipment does not operate properly, stop operation.

After mounting is completed, confirm that it has been done correctly by performing a suitable function test.

2. Do not apply external force to the coil section.

When tightening is performed, apply a wrench or other tool to the outside of the piping connection parts.

3. Be sure not to position the coil downwards.

When mounting a valve with its coil positioned downwards, foreign objects in the fluid will adhere to the iron core leading to a malfunction.

4. Do not warm the coil assembly with a heat insulator, etc.

Use tape, heaters, etc., for freeze prevention on the piping and body only. They can cause the coil to burn out.

5. Secure with brackets, except in the case of steel piping and copper fittings.

6. Avoid sources of vibration, or adjust the arm from the body to the minimum length so that resonance will not occur.

7. Painting and coating

Warnings or specifications printed or labeled on the product should not be erased, removed or covered up.

Piping

⚠ Caution

1. Preparation before piping

Before piping is connected, it should be thoroughly blown out with air (flushing) or washed to remove chips, cutting oil and other debris from inside the pipe.

Avoid pulling, compressing, or bending the valve body when piping.

2. Wrapping of pipe tape

When connecting pipes, fittings, etc., be sure that chips from the pipe threads and sealing material do not enter the valve.

Furthermore, when pipe tape is used, leave 1.5 to 2 thread ridges exposed at the end of the threads.

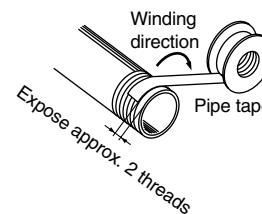

3. Avoid connecting ground lines to piping, as this may cause electric corrosion of the system.

4. Always tighten threads with the proper tightening torque.

When attaching fittings to valves, tighten with the proper tightening torque shown below.

Tightening Torque for Piping

Connection threads	Proper tightening torque N·m
Rc 1/8	7 to 9
Rc 1/4	12 to 14
Rc 3/8	22 to 24
Rc 1/2	28 to 30
Rc 3/4	
Rc 1	36 to 38

5. Connection of piping to products

When connecting piping to a product, refer to its instruction manual to avoid mistakes regarding the supply port, etc.

6. Steam generated in a boiler contains a large amount of drainage.

Be sure to operate it with a drain trap installed.

7. In applications such as vacuum and non-leak specifications, use caution specifically against the contamination of foreign matters or airtightness of the fittings.



2 Port Solenoid Valve for Fluid Control/Precautions 3

Be sure to read this before handling.

For detailed precautions on each series, refer to the main text.

Wiring

⚠ Caution

- 1 As a rule, use electrical wire with a cross sectional area of 0.5 to 1.25 mm² for wiring. Furthermore, do not allow excessive force to be applied to the lines.
2. Use electrical circuits which do not generate chattering in their contacts.
3. Use voltage which is within $\pm 10\%$ of the rated voltage. In cases with a DC power supply where importance is placed on responsiveness, stay within $\pm 5\%$ of the rated value. The voltage drop is the value in the lead wire section connecting the coil.
4. When a surge from the solenoid affects the electrical circuitry install a surge absorber etc., in parallel with the solenoid. Or adopt an option that comes with the surge voltage protection circuit. (However a surge voltage occurs even if the surge voltage protection circuit is used For details, please consult with us.)

Electrical Connection

⚠ Caution

Grommet

Class H coil: AWG18 Insulator O.D. 2.2 mm

Class B coil: AWG20 Insulator O.D. 2.5 mm

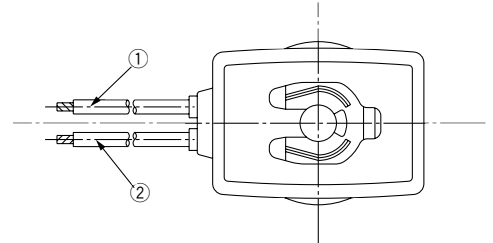

Rated voltage	Lead wire color	
	①	②
DC (Class B only)	Black	Red
100 VAC	Blue	Blue
200 VAC	Red	Red
Other AC	Gray	Gray

* There is no polarity.

DIN connector (Class B only)

Since internal connections are as shown below for the DIN connector make connections to the power supply accordingly

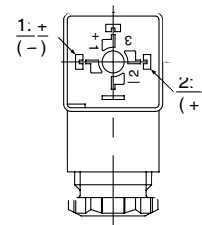

Terminal no.	1	2
DIN terminal	+ (-)	- (+)

* There is no polarity.

- Use compatible heavy duty cords with cable O.D. of $\phi 6$ to 12.
- Use the tightening torques below for each section.

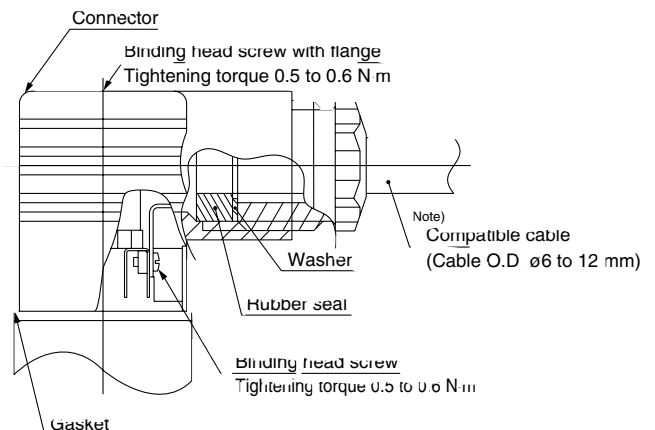

Note) For an outside cable diameter of $\phi 9$ to 12 mm, remove the internal parts of the rubber seal before using.



2 Port Solenoid Valve for Fluid Control/Precautions 4

Be sure to read this before handling.

For detailed precautions on each series, refer to the main text.

Electrical Connection

Caution

Conduit terminal

In the case of the conduit terminal make connections according to the marks shown below

- Use the tightening torques below for each section.
- Properly seal the terminal connection (G1/2) with the special wiring conduit, etc.

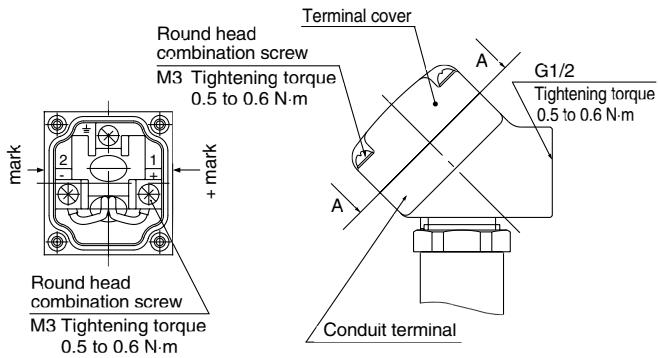

View A-A
(Internal connection diagram)

Conduit

When used as an IP65 equivalent, use seal (part no. VCW20-15-6) to install the wiring conduit. Also, use the tightening torque below for the conduit.

Class H coil: AWG18 Insulator O.D. 2.2 mm
Class B coil: AWG20 Insulator O.D. 2.5 mm

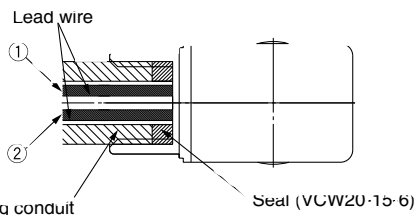

Rated voltage	Lead wire color	
	①	②
DC	Black	Red
100 VAC	Blue	Blue
200 VAC	Red	Red
Other AC	Gray	Gray

* There is no polarity for DC.

Description	Part no.
Seal	VCW20-15-6

Note) Please order separately.

Electrical Circuit

Caution

DC circuit

Grommet, Conduit, Conduit terminal, DIN connector

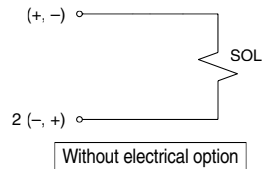

Grommet, Conduit terminal, DIN connector

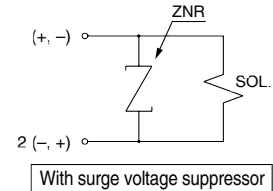

Conduit terminal, DIN connector

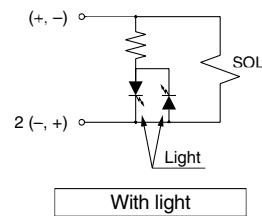

Conduit terminal, DIN connector

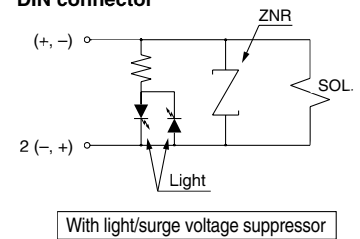

AC/Class B (with a full-wave rectifier) coil circuit

* Surge voltage suppressor is attached to the AC/Class B coil, as a standard.

Grommet, Conduit, Conduit terminal, DIN connector

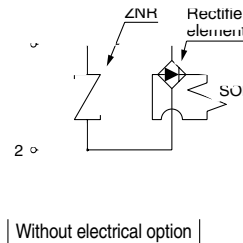

Conduit terminal, DIN connector

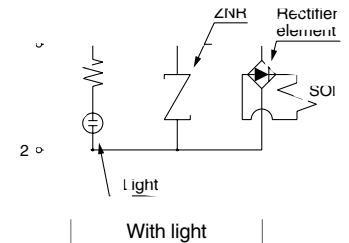

AC/Class B, II coil circuit

Grommet, Conduit, Conduit terminal

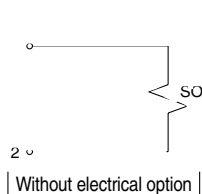

Grommet, Conduit terminal

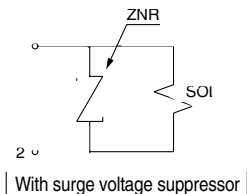

Conduit terminal

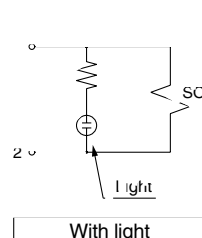

Conduit terminal

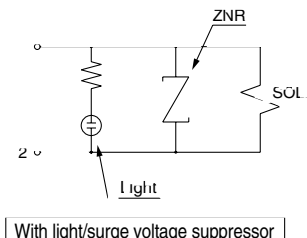



2 Port Solenoid Valve for Fluid Control/Precautions 5

Be sure to read this before handling.

For detailed precautions on each series, refer to the main text.

Operating Environment

Warning

1. Do not use the valves in an atmosphere having corrosive gases, chemicals, salt water, water, steam, or where there is direct contact with any of these.
2. Do not use in explosive atmospheres.
3. Do not use in locations subject to vibration or impact.
4. Do not use in locations where radiated heat will be received from nearby heat sources.
5. Employ suitable protective measures in locations where there is contact with water droplets, oil or welding spatter, etc.

Lubrication

Caution

1. This solenoid valve can be operated without lubrication.

If a lubricant is used in the system, use turbine oil Class 1, ISO VG32 (with no additive). But do not lubricate a valve with EPDM seal.

Refer to the table of brand name of lubricants compliant with Class 1 turbine oil (with no additive), ISO VG32.

Class 1 Turbine Oil (with no additive), ISO VG32

Classification of viscosity (cst) (40°C)	Viscosity according to ISO Grade	32
Idemitsu Kosan Co.,Ltd.		Turbine oil P-32
Nippon Oil Corp.		Turbine oil 32
Cosmo Oil Co.,Ltd.		Cosmo turbine 32
Japan Energy Corp.		Kyodo turbine 32
Kygnus Oil Co.		Turbine oil 32
Kyushu Oil Co.		Stork turbine 32
Nippon Oil Corp.		Mitsubishi turbine 32
Showa Shell Sekiyu K.K.		Turbine 32
Tonen General Sekiyu K.K.		General R turbine 32
Fuji Kosan Co.,Ltd.		Fucoal turbine 32

Please contact SMC regarding Class 2 turbine oil (with additives), ISO VG32.

Maintenance

Warning

1 Removing the product

The valve will reach a high temperature when used with high temperature fluids. Confirm that the valve temperature has dropped sufficiently before performing work. If touched inadvertently, there is a danger of being burned.

1. Shut off the fluid supply and release the fluid pressure in the system.
2. Shut off the power supply.
3. Demount the product.

2. Low frequency operation

Switch valves at least once every 30 days to prevent malfunction. Also, in order to use it under the optimum state, conduct a regular inspection once a half year.

Caution

1. Filters and strainers

1. Be careful regarding clogging of filters and strainers.
2. Replace filter elements after one year of use, or earlier if the pressure drop reaches 0.1 MPa.
3. Clean strainers when the pressure drop reaches 0.1 MPa.

2. Lubrication

When using after lubricating, never forget to lubricate continuously.

3. Storage

In case of long term storage after use with heated water, thoroughly remove all moisture to prevent rust and deterioration of rubber materials, etc.

4. Exhaust the drain from an air filter periodically.

Operating Precautions

Warning

1. Valves will reach high temperatures from high temperature fluids. Use caution, as there is a danger of being burned if a valve is touched directly.



SMC'S GLOBAL MANUFACTURING, DISTRIBUTION AND SERVICE NETWORK

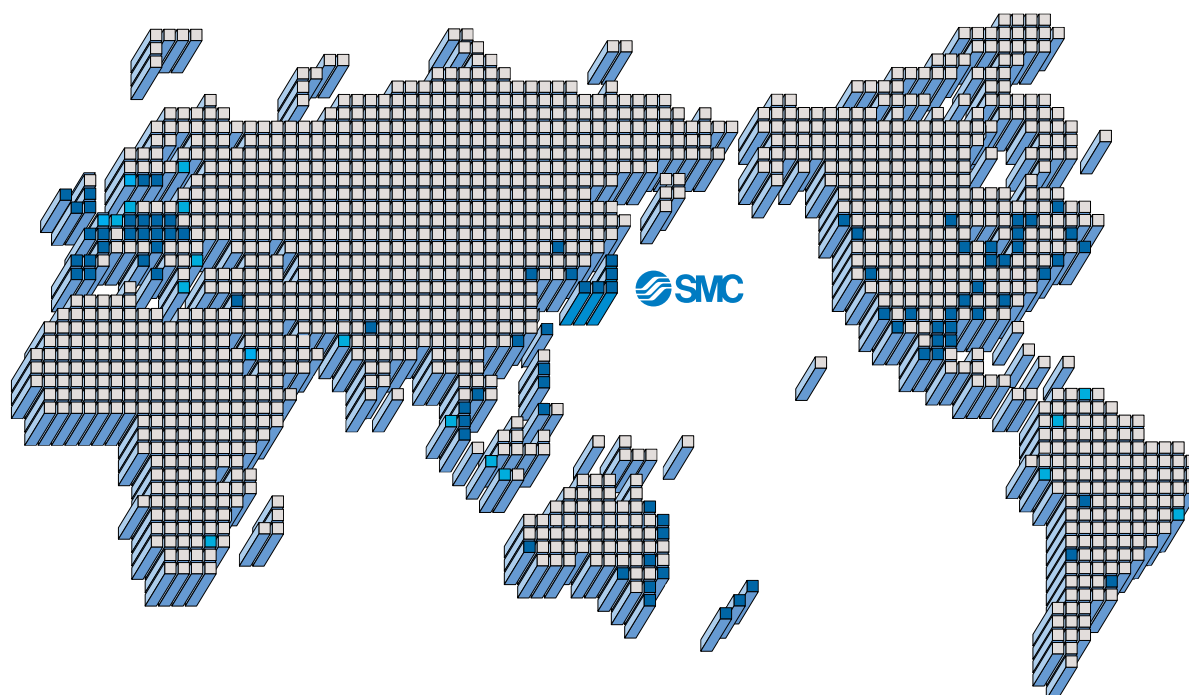

EUROPE

AUSTRIA

SMC Pneumatik GmbH

BELGIUM

SMC Pneumatics N.V./S.A.

BULGARIA

SMC Industrial Automation Bulgaria EOOD

CROATIA

SMC Industrijska automatika d.o.o.

CZECH REPUBLIC

SMC Industrial Automation CZ s.r.o.

DENMARK

SMC Pneumatik A/S

ESTONIA

SMC Pneumatics Estonia OÜ

FINLAND

SMC Pneumatics Finland OY

FRANCE

SMC Pneumatique SA

GERMANY

SMC Pneumatik GmbH

HUNGARY

SMC Hungary Ipari Automatizálási Kft.

IRELAND

SMC Pneumatics (Ireland) Ltd.

ITALY

SMC Italia S.p.A.

LATVIA

SMC Pnuematics Latvia SIA

NETHERLANDS

SMC Pneumatics BV

NORWAY

SMC Pneumatics Norway A/S

POLAND

SMC Industrial Automation Polska Sp.z.o.o.

ROMANIA

SMC Romania s.r.l.

RUSSIA

SMC Pneumatik LLC.

SLOVAKIA

SMC Priemyselna automatizacia, s.r.o.

SLOVENIA

SMC INDUSTRIJSKA AVTOMATIKA d.o.o.

SPAIN/PORTUGAL

SMC España, S.A.

SWEDEN

SMC Pneumatics Sweden AB

SWITZERLAND

SMC Pneumatik AG

UK

SMC Pneumatics (U.K.) Ltd.

ASIA

CHINA

SMC (China) Co., Ltd.

HONG KONG

SMC Pneumatics (Hong Kong) Ltd

INDIA

SMC Pneumatics (India) Pvt. Ltd.

INDONESIA

PT SMC Pneumatics Indonesia

MALAYSIA

SMC Pneumatics (S.E.A.) Sdn. Bhd.

PHILIPPINES

SHOKETSU-SMC Corporation

SINGAPORE

SMC Pneumatics (S.E.A.) Pte. Ltd.

SOUTH KOREA

SMC Pneumatics Korea Co., Ltd.

TAIWAN

SMC Pneumatics (Taiwan) Co., Ltd

THAILAND

SMC Thailand Ltd.

NORTH AMERICA

CANADA

SMC Pneumatics (Canada) Ltd.

MEXICO

SMC Corporation (Mexico) S.A. de C.V.

USA

SMC Corporation of America

SOUTH AMERICA

ARGENTINA

SMC Argentina S.A.

BOLIVIA

SMC Pneumatics Bolivia S.R.L.

BRAZIL

SMC Pneumaticos Do Brazil Ltda.

CHILE

SMC Pneumatics (Chile) S.A.

VENEZUELA

SMC Neumatica Venezuela S.A.

OCEANIA

AUSTRALIA

SMC Pneumatics (Australia) Pty Ltd.

NEW ZEALAND

SMC Pneumatics (N.Z.) Ltd.

SMC Corporation

1-16-4 Shimbashi, Minato-ku, Tokyo 105-8659 JAPAN

Tel: 03-3502-2740 Fax: 03-3508-2480

URL <http://www.smcworld.com>

© 2005 SMC Corporation All Rights Reserved

Specifications are subject to change without prior notice
and any obligation on the part of the manufacturer.

D-DN

1st printing JV printing JV 120DN Printed in Japan.

This catalog is printed on recycled paper with concern for the global environment.