

Valve Mounted Guide Cylinder

Series MVGQ

ø12, ø16, ø20, ø25, ø32, ø40, ø50, ø63, ø80, ø100

Valve, Speed Controller, and Cylinder are formed into one unit.

Easy piping wiring work for Valve, Speed Controller and Cylinder can be formed into one unit, further can be equipped into a more compact design.

The optimum valve series for each bore size

ø12, ø16, ø20	ø25, ø32	ø40, ø50, ø63	ø80, ø100
Valve: SYJ3000	VZ3000	VZ5000	VF3000

Switching between rod extended when energized and rod retracted when energized is easy.

It is able to switch easily by changing the orientation of the switching plate for Series SYJ3000, VZ3000, VZ5000, and by changing the mounting orientation of the valve for Series VF3000.

Can be mounted from two directions.

Non-rotating accuracy

Cylinder position can be detected.

Built-in magnet for auto-switches

Built-in speed controller

Selection of meter-out or meter-in control is possible.

Two kinds of guide rod bearings suited for individual use

Slide Bearing

Strength against side load is more than 2 times* as compared conventional stopper cylinder (round bar type). Suitable for use with lateral loads accompanied by impact, as in stoppers.

Ball Bushing Bearing

Smooth operation is suitable for pushing, lifter and applications. (*Comparison to SMC RSQ□ series, round bar type)



Maximum Driving Speed of Cylinders

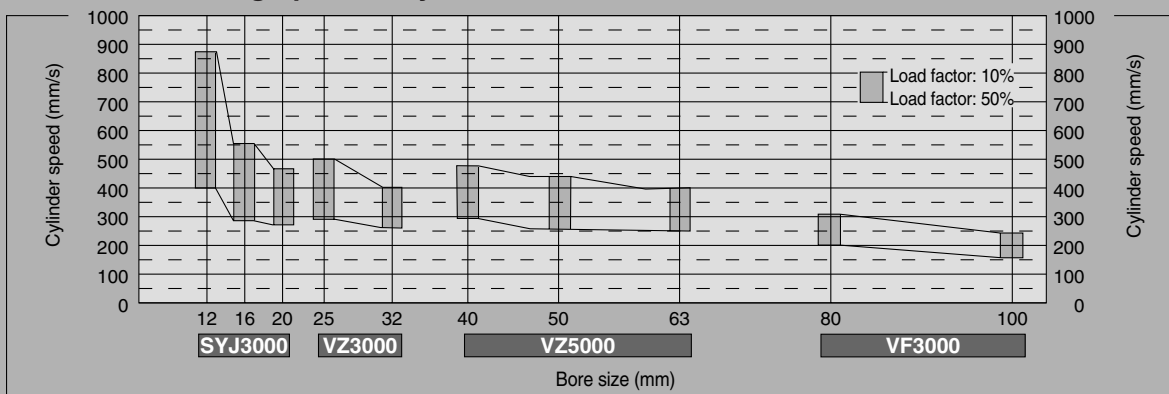

Series Variations

Bore size (mm)	Standard stroke (mm)										Applicable valve series	Positions/No. of solenoid	Effective area (mm ²) (Cv factor)	Detailed specifications			
	10	20	25	30	40	50	75	100	125	150					175	200	
12	●	●											SYJ3000	2 position	Single	1.2 (0.067)	P.1648
16	●	●															
20		●		●	●	●	●	●	●	●	●	●					
25		●		●	●	●	●	●	●	●	●	●	VZ3000	2 position	Single	4.5 (0.25)	P.1652
32			●	●	●	●	●	●	●	●	●	●					
40			●	●	●	●	●	●	●	●	●	●	VZ5000	2 position	Single		
50			●	●	●	●	●	●	●	●	●	●				Double	
63			●	●	●	●	●	●	●	●	●	●	VF3000	2 position	Single		16 (0.9)
80			●	●	●	●	●	●	●	●	●	●				Double	
100			●	●	●	●	●	●	●	●	●	●					

CV□

MVGQ

D-□

-X□

Individual
-X□



Series MVGQ Precautions 1

Be sure to read before handling.

Selection

Warning

1. Confirm the specifications.

Products in this catalog are designed to be used for compressed air systems (including vacuum). If not operated within the designated pressure or temperature, it may damage the products or cause malfunction. (Refer to specifications.)

2. Energizing continuously for a long period of time.

When the valve is continuously energized for a long period of time, the performance may deteriorate, shorten the service life or effect peripheral equipment adversely since temperature rises when coils generate heat. Use the DC specification and energy saving circuit types when the valve is energized for a long period of time or energizing time becomes longer than non-energizing time during a day. Another way will be to make the valve N.O. (Normally Open), which shortens energizing time.

Manual Operation

Warning

Since the devices in connection are operated by manual override, make sure that there is no danger.

■ Non-locking push type [Standard type]

Push in the direction of the arrow.

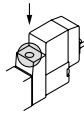

■ Push-turn locking slotted type [D type]

Push and turn in the direction of the arrow.

If this is not turned, it can be used in the same way as the non-locking push type.

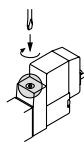

The position when locked



Caution

When operating D type with the driver, use a watchmaker's screwdriver and turn it lightly. [Torque: Less than 0.1 N•m]

■ Push-turn locking lever type [E type]

Push and turn in the direction of the arrow.

If this is not turned, it can be used in the same way as the non-locking push type.

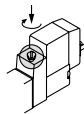

The position when locked

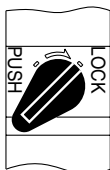

Caution

When locking the manual override with the push-turn locking type (D and E types), be sure to push it down before turning. Turning without first pushing it down can cause damage to the manual override and malfunction such as air leakage, etc.

Plug Connector

Caution

1. Connector installation and removal

- To install the connector, squeeze the lever and the connector body with your fingers, slide the connector straight over the pin, and lock it in place by pushing the tab of the lever into the groove in the cover.
- To remove the connector, press the lever with your thumb to disengage the tab from the groove, and pull the connector straight out.

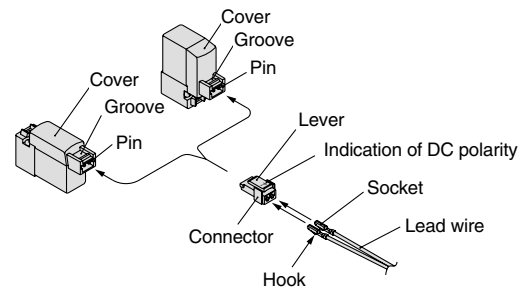

2. Crimping the lead wire into the socket

Peel approximately 3.2 to 3.7 mm of insulation from the tip of the lead wire, make sure that the ends of the core wire are even, insert the wire into the socket, and crimp it with a crimping tool.

At this time, make sure that the insulation of the lead wire does not enter the area in which the core wire is crimped. (Please contact SMC for details on the special crimping tool.)

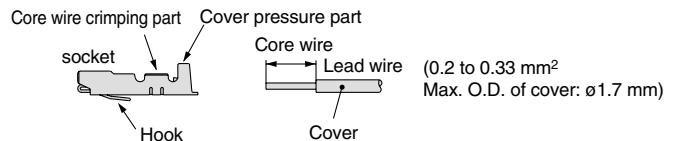

3. Attaching and detaching lead wires with sockets

● Attaching

Insert the sockets into the square holes of the connector (with \oplus and \ominus indication), continue to push the sockets all the way in until the lock by hooking into the seats in the connector. (When they are pushed in, their hooks open and they are locked automatically.) Then confirm that they are locked by pulling lightly on the lead wires.

● Detaching

To detach a socket from a connector, pull out the lead wire while pressing the socket's hook with a stick having a thin tip (approx. 1 mm).

If the socket is re-used as it is, spread the hook to the outside.

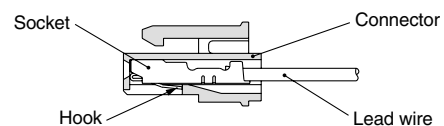



Series MVGQ Precautions 2

Be sure to read before handling.

Surge Voltage Suppressor

⚠ Caution

< For DC >

Grommet, L/M plug connector

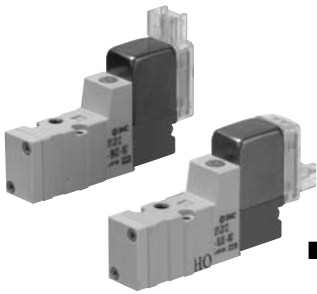

■ Standard type (With polarity) With surge voltage suppressor (□S)

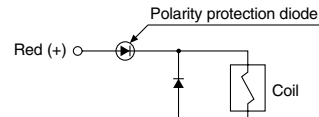

With light/surge voltage suppressor (□Z)

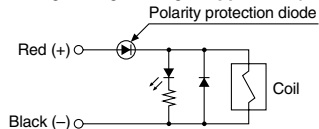

■ Non-polar type With surge voltage suppressor (□R)

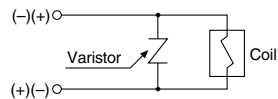

With light/surge voltage suppressor (□U)

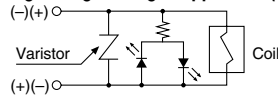

- Connect the wires by matching their polarities to the + and - marks. (Non-polar type can be connected to either of them.)
- Since the electrical voltage other than 24 VDC, 12 VDC have no feature of polarity protection diode, use caution not to make a mistake of the polarity.
- Valves with diode to prevent reverse current have a voltage drop of approximately 1 V. Be aware of the allowable voltage fluctuation. (Refer to solenoid specifications of each valve for details.)
- If the lead wires are connected beforehand, the red wire is +, and the black wire is -.

■ With energy saving circuit

By reducing electric power required in the holding state, power consumption is reduced to about 1/4 of the standard type. (Effective energizing time is over 62 ms when 24 VDC is applied.)

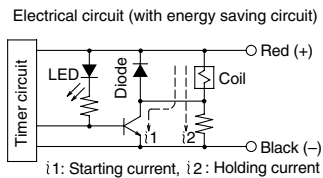

Working Principle

The circuit shown above reduces current consumption at holding, which reduces the overall power consumption. Refer to the electrical power waveform shown on the right.

- Since the product with an energy-saving circuit does not have a diode to prevent reverse current, avoid mistaking polarity.
- Be aware of the allowable voltage fluctuation, since there is about 0.5 voltage drop due to a transistor. (Refer to solenoid specifications of each valve for details.)

<Energy-saving electrical power waveform, for SYJ 3/7 □□OT>

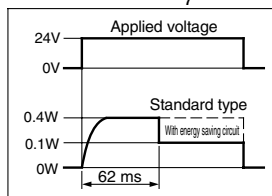

M8 connector

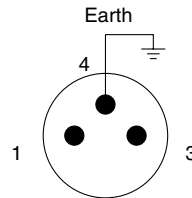

Solenoid valve side pin wiring diagram

■ Standard type (With polarity) With surge voltage suppressor (□S)

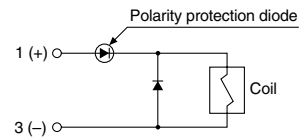

With light/surge voltage suppressor (□Z)

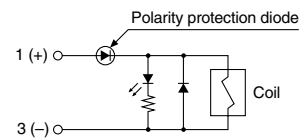

■ Non-polar type With surge voltage suppressor (□R)

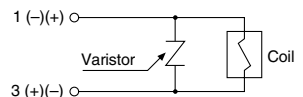

With light/surge voltage suppressor (□U)

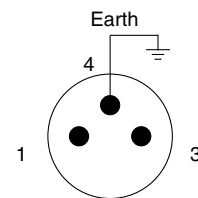
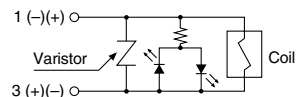

Solenoid valve side pin wiring diagram

- Since the standard type has polarity, connect + to 1 and - to 3.
- Since the electrical voltage other than 24 VDC, 12 VDC have no feature of polarity protection diode, use caution not to make a mistake of the polarity.
- Valves with diode to prevent reverse current have a voltage drop of approximately 1 V. Be aware of the allowable voltage fluctuation. (Refer to solenoid specifications of each valve for details.)

Surge Voltage Suppressor

< For AC >

(Since the rectifier prevents the production of surge voltage, there is no S type.)

Grommet, L/M plug connector

With indicator light (□Z)

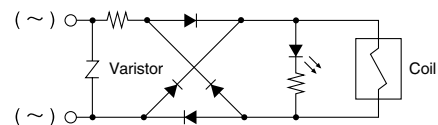

CV □

MVGQ

D- □

-X □

Individual
-X □



Series MVGQ Precautions 3

Be sure to read before handling.

M8 Connector

⚠ Caution

- M8 connectors compliant with IP65 (enclosure) are protected against dust and water, however, they cannot be used in water.
Use SMC's lead wire assembly (V100-49-1-□) or a connector for FA sensor (M8 thread 3 pin type) conforming to NECA (Nippon Electric Control Equipment Industries Association) standard 4202 (IEC60947-5-2) for the connectors used. When the connectors are used with SYJ3000 manifolds, use the connectors with O.D. 10.5 mm or smaller. If the connectors have O.D. 10.5 mm or greater, they cannot be connected since they interfere with manifolds.
- When installing connectors, be sure to tighten them by hand since using tools may damage them. (0.4 to 0.6 N·m)
- Do not apply a force of 30N or more since it may not meet IP65.

⚠ Caution

When using connectors other than M8 or not tightening them sufficiently, IP65 cannot be met.

- How to mount connectors with a lead wire

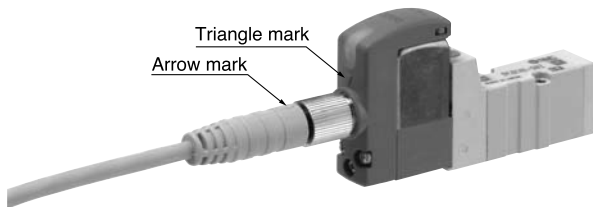

Note) When installing a connector cable, directions must be confirmed. When installing SMC's connector cable (V100-49-1-□), align the arrow mark of the connector and the triangle mark of the valve.
Twisting without alignment may damage pins and cause malfunction.

■ Connector Cable

- Refer to how to order the connector cable for M8 shown below.

How to order

- When ordering the solenoid valve and the connector cable at the same time
(Connector cable is shipped together.)

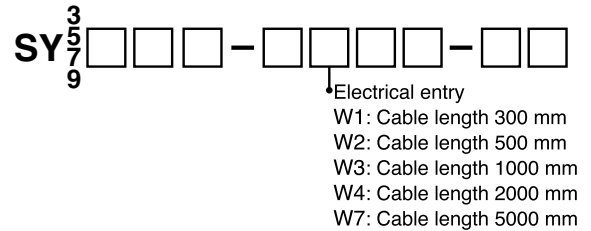

(Example 1) Cable length 300 mm
SY312-5W1ZE-C4

□ Cable entry symbol

- When ordering a connector cable only

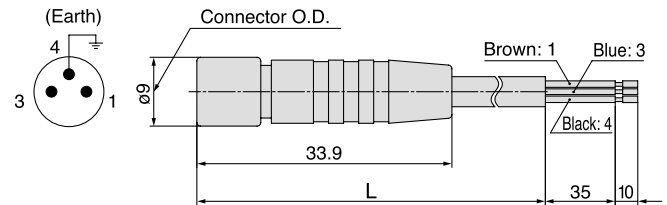

Cable length (L)	Model
300 mm	V100-49-1-1
500 mm	V100-49-1-2
1000 mm	V100-49-1-3
2000 mm	V100-49-1-4
5000 mm	V100-49-1-7

[Dimensions when installed]

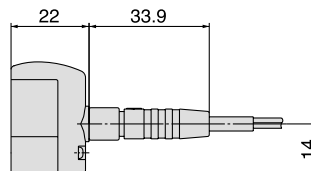

Valve Mounted Guide Cylinder Series **MVGQ**

ø12, ø16, ø20

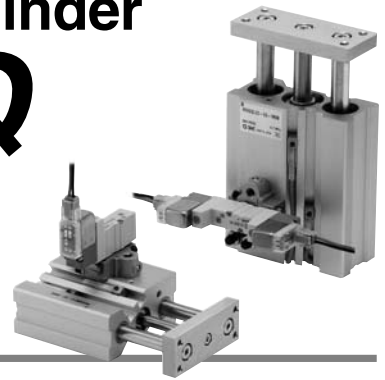

How to Order

How to Order

When ordering valve mounted guide cylinder, Series MVGQ, specify the models of both the cylinder and the valve.

Ex.) MVGQM12-30-M9BWM-B 1
SYJ3130-5LZ-MA 1

Cylinder stroke (mm)

Refer to page 1649 for standard strokes.

Bore size

12	12 mm
16	16 mm
20	20 mm

Bearing

M	Slide bearing
L	Ball bushing bearing

Auto switch

Nil	Without auto switch (Built-in magnet)
-----	---------------------------------------

* For the applicable auto switch model, refer to page 1649.

Number of auto switches

Nil	2 pcs.
S	1 pc.
n	n pcs.

Rod extended/retracted when energized

Nil	Rod extended when energized
B	Rod retracted when energized

Note) Based on the case of 2 position single solenoid valve.

Cylinder

MVGQ **M** **12** - **30** - **M9BW** [] - [] - []

Valve

SYJ3 **1** **3** **0** [] - **5** **L** **Z** [] - **MA** - []

Type of actuation

1	2 position single solenoid
2	2 position double solenoid

* Please consult with SMC for 3 position type.

Speed controller specifications

MA	Meter-out
MB*	Meter-in

Made to Order

* Refer to page 1649 for details.

Coil specification

Nil	Standard
T	With energy saving circuit (24/12 VDC only)

* The energy saving circuit is not available for W□.

DC specifications AC specifications (50/60 Hz)

5	24 VDC	1	100 VAC
6	12 VDC	2	200 VAC
V	6 VDC	3	110 VAC [115 VAC]
S	5 VDC	4	220 VAC [230 VAC]
R	3 VDC	* W□: DC only	

200 VAC, 220 VAC specifications

An AC specification solenoid valve using a grommet, L, or M plug connector has a built-in rectifier circuit in its pilot valve section to activate the DC coil. The 200 VAC or 220 VAC specification pilot valve contains a rectifier circuit that generates heat when it is energized. Therefore, do not touch its exterior surface because it could be very hot, depending on the energizing conditions.

Body option

0: Pilot valve individual exhaust type

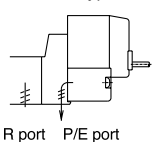

R port P/E port

3: Main/Pilot valve common exhaust type

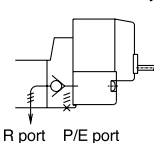

R port P/E port

Manual override

Nil: Non-locking push type

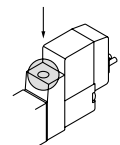

D: Push-turn locking slotted type

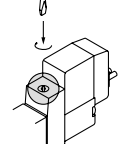

E: Push-turn locking lever type

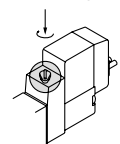

Electrical entry

24 V, 12 V, 6 V, 5 V, 3 VDC 100 V, 110 V, 200 V, 220VAC				24 V, 12 VDC 6 V, 5 V, 3 VDC	
Grommet	L plug connector	M plug connector		M8 connector	
G: Lead wire length: 300 mm	L: With lead wire (Wire length: 300 mm)	M: With lead wire (Wire length: 300 mm)	MN: Without lead wire	WO: Without connector cable	
H: Lead wire length: 600 mm	LN: Without lead wire	LO: Without connector	MO: Without connector	W□: With connector cable	

Light/Surge voltage suppressor

Nil	Without light/surge voltage suppressor
S	With surge voltage suppressor
Z	With light/surge voltage suppressor
R	With surge voltage suppressor (No polarity)
U	With light/surge voltage suppressor (No polarity)

* In the case of AC, since the rectifier prevents the production of surge voltage, there is no type "S".
* R, U: DC only
* With energy saving circuit: For type "Z" only

* 2 sockets are attached to "LN" and "MN" types.
* Refer to page 1646 for the connector cable for M8.
Note 1) □: Cable length symbol. Insert the symbol referring to page 1646.

JIS Symbol

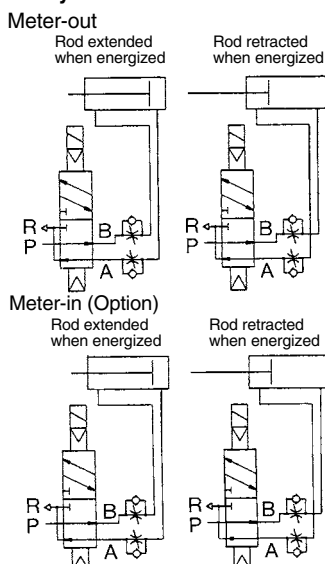

The allowable lateral load, the allowable rotational torque for a plate, and the operation range of a stopper are the same as these of Series MGQ. For details, refer to pages 337 to 351.

Standard Stroke

Model	Standard stroke (mm)
MVGQ ^M _L 12/16	10, 20, 30, 40, 50, 75, 100
MVGQ ^M _L 20	20, 30, 40, 50, 75, 100 125, 150, 175, 200

Intermediate stroke (mm)

As for the intermediate strokes (by the 1 mm interval) other than the standard strokes above are manufactured by means of installing a spacer.

Example) In the case of MVGQM20-35 st, a 5 mm width spacer is installed in the MVGQM20-40 st body; thus, the full length dimension are the same as the 40 st.



Made to Order Specifications

(For details, refer to pages 1847.)

Symbol	Specifications
-XA□	Change of guide rod end shape
-XC79	Tapped hole, drilled hole, pinned hole machined additionally

Specifications

Bore size (mm)	12, 16, 20	
Action	Double acting	
Fluid	Air	
Bearing type	Slide bearing (MVGQM), Ball bushing bearing (MVGQL)	
Operating pressure range (MPa)	2 position single	0.15 to 0.7
	2 position double	ø12, ø16: 0.12 to 0.7, ø20: 0.1 to 0.7
Ambient and fluid temperature (°C)	-10 to 50°C (No freezing)	
Piston speed (mm/s)	50 to 500 (Refer to the page 1643.)	
Cushion	Rubber bumper on both ends	
Lubrication	Non-lube	
Stroke length tolerance (mm)	+1.5 0	

Solenoid Valve Specifications

Model	Series SYJ3000		
Manual override	Non-locking push type, Push-turn locking slotted type, Push-turn locking lever type		
Pilot exhaust	Pilot valve individual exh. style, Main/Pilot valve common exh. style		
Shock/Impact resistance (m/s ²) ⁽¹⁾	150/30		
Enclosure	Dustproof (* M8 connector: IP65)		
Electrical entry	Grommet (G)/(H), L plug connector (L), M plug connector (M), M8 connector (W)		
Coil rated voltage (V)	DC	24, 12, 6, 5, 3	
	AC50/60 Hz	100*, 110*, 200*, 220*	
Allowable voltage	±10% of the rated voltage*		
Power consumption ⁽²⁾	DC	Standard type	0.35 (With indicator light: 0.4)
		With energy saving circuit	0.1 (With indicator light only)
Apparent power ⁽²⁾ (VA)	AC	100 V	0.78 (With indicator light: 0.81)
		110 V [115 V]	0.86 (With indicator light: 0.89) [0.94 (With indicator light: 0.97)]
		200 V	1.18 (With indicator light: 1.22)
		220 V [230 V]	1.30 (With indicator light: 1.34) [1.42 (With indicator light: 1.46)]
Surge voltage suppressor	Diode (Non-polar type: Varistor)		
Indicator light	LED		

* Conforming to IEC60529

* 100 VAC and 115 VAC, 200 VAC and 230 VAC are common.

* Allowable voltage fluctuation for 115 VAC or 230 VAC is -15 to +5% of the rated voltage.

* For types S, Z and T with an energy saving circuit, the voltage will drop due to the internal circuit. Allowable voltage fluctuation must be in the range below.

Types S, Z 24 VDC: -7 to +10%, 12 VDC: -4 to +10%

Type T 24 VDC: -8 to +10%, 12 VDC: -6 to +10%

Note 1) Impact resistance: No malfunction resulted from the impact test using a drop impact tester. The test was performed on the axis and right angle directions of the main valve and armature, one time each in both energized and de-energized states.

Vibration resistance: No malfunction occurred in a one-sweep test between 45 and 2000 Hz. Test was performed at both energized and de-energized states to the axis and right angle directions of the main valve and armature. (Value in the initial stage.)

Note 2) At the rated voltage.

Applicable Auto Switch/Refer to pages 1719 to 1827 for further information on auto switches.

Type	Special function	Electrical entry	Indicator light	Wiring (Output)	Load voltage		Auto switch model		Lead wire length (m)				Pre-wired connector	Applicable load	
					DC	AC	Perpendicular	In-line	0.5 (Nil)	1 (M)	3 (L)	5 (Z)		IC circuit	Relay, PLC
Solid state switch	Diagnostic indication (2-color indication)	Grommet	Yes	3-wire (NPN)	24 V	5 V, 12 V	—	M9NV	M9N	●	●	○	○	—	—
				3-wire (PNP)				M9PV	M9P	●	●	○	○		
				2-wire				M9BV	M9B	●	●	○	○		
				3-wire (NPN)				M9NWV	M9NW	●	●	○	○		
				3-wire (PNP)				M9PWV	M9PW	●	●	○	○		
				2-wire				M9BWV	M9BW	●	●	○	○		
Reed switch	—	Grommet	No	3-wire (NPN equivalent)	24 V	5 V	—	A96V	A96	●	—	●	—	—	—
				2-wire				100 V	12 V	A93V	A93	●	—	●	—
						100 V or less		A90V	A90	●	—	●	—	—	—

* Lead wire length symbols: 0.5 m Nil (Example) M9NW
1 m M (Example) M9NW
3 m L (Example) M9NL
5 m Z (Example) M9NZ

* Solid state auto switches marked with "○" are produced upon receipt of order.

* Since there are other applicable auto switches than listed, refer to page 1665 for details.

* For details about auto switches with pre-wired connector, refer to pages 1784 and 1785.

* Auto switches are shipped together (not assembled).

Series *MVGQ*

Low Power Consumption 0.5 W

Solenoid Specifications

Power consumption (W)	0.5 (With indicator light: 0.55)
Coil rated voltage (V)	24, 12, 6, 5, 3 VDC

Mass

(kg)

Bearing type	Bore size (mm)	Type	Standard stroke (mm)											
			10	20	30	40	50	75	100	125	150	175	200	
Slide bearing	12	MVGQM12	0.23	0.28	0.32	0.35	0.39	0.49	0.59	-	-	-	-	
	16	MVGQM16	0.35	0.40	0.46	0.51	0.56	0.69	0.81	-	-	-	-	
	20	MVGQM20	-	0.55	0.62	0.70	0.77	0.95	1.10	1.25	1.40	1.55	1.70	
Ball bushing bearing	12	MVGQL12	0.24	0.27	0.30	0.36	0.39	0.47	0.54	-	-	-	-	
	16	MVGQL16	0.36	0.40	0.45	0.53	0.58	0.71	0.83	-	-	-	-	
	20	MVGQL20	-	0.55	0.61	0.71	0.76	0.91	1.05	1.19	1.33	1.47	1.61	

Note) The factors indicated above are of the single solenoid with grommet (G). Add 0.01 kg for the double solenoids.

Changing between Rod Extended when Energized and Rod Retracted when Energized

SYJ3000

How to Handle Speed Controller

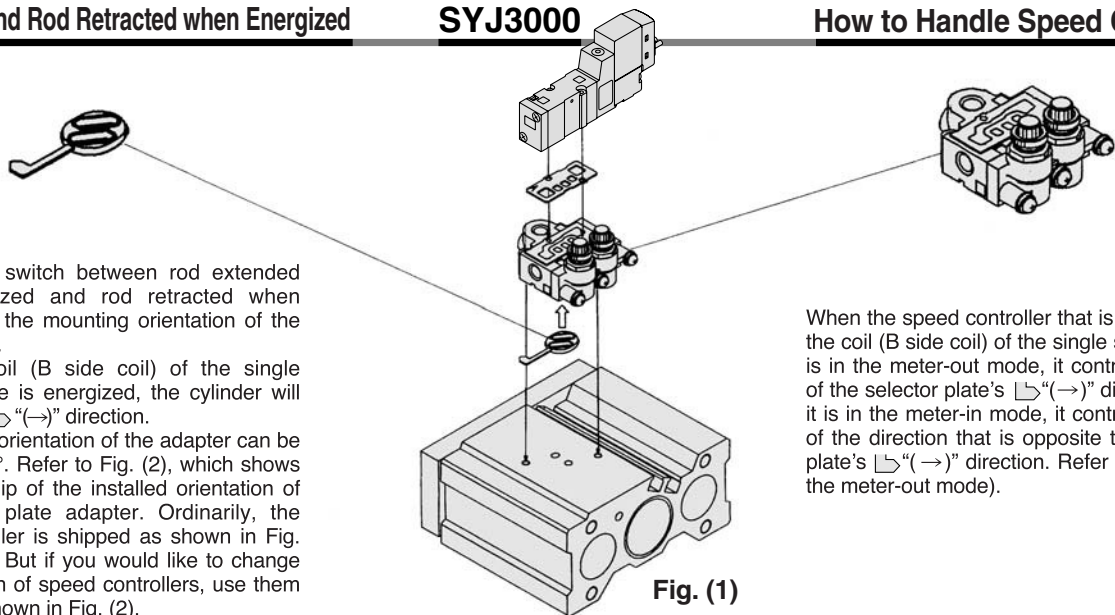

It is able to switch between rod extended when energized and rod retracted when energized by the mounting orientation of the selector plate.

When the coil (B side coil) of the single solenoid valve is energized, the cylinder will move in the \rightarrow direction.

The installed orientation of the adapter can be changed 180°. Refer to Fig. (2), which shows the relationship of the installed orientation of the selector plate adapter. Ordinarily, the speed controller is shipped as shown in Fig. (2) (a) or (b). But if you would like to change the orientation of speed controllers, use them in (c) or (d) shown in Fig. (2).

When the speed controller that is on the side of the coil (B side coil) of the single solenoid valve is in the meter-out mode, it controls the speed of the selector plate's \rightarrow direction. When it is in the meter-in mode, it controls the speed of the direction that is opposite to the selector plate's \rightarrow direction. Refer to Fig. (3) for the meter-out mode).

Fig. (2)

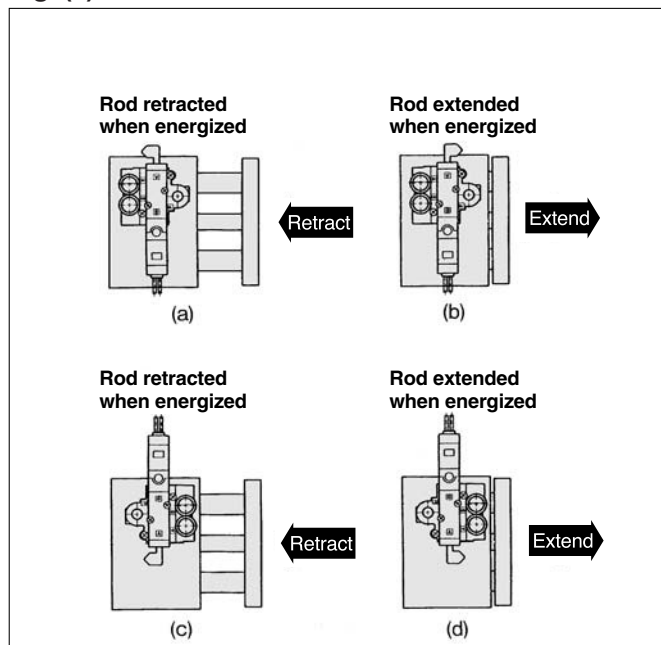
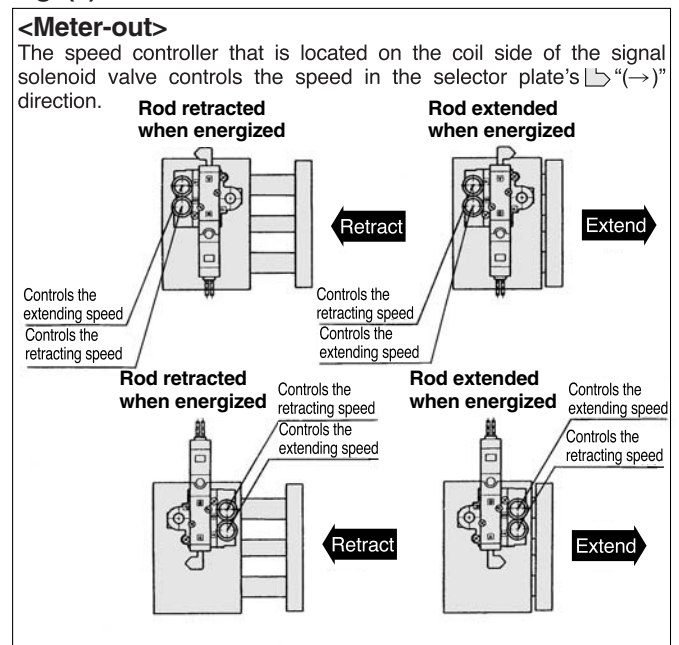

Fig. (3)



Valve Mounted Guide Cylinder *Series MVGQ*

ø12, ø16, ø20

MVGQM, MVGQL

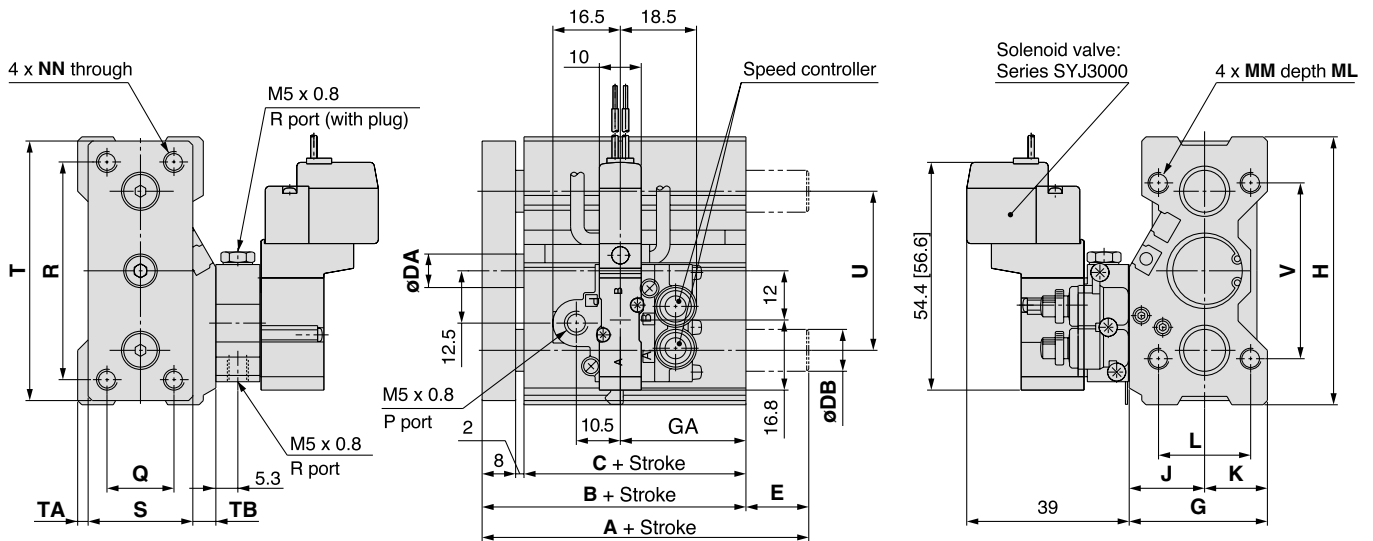
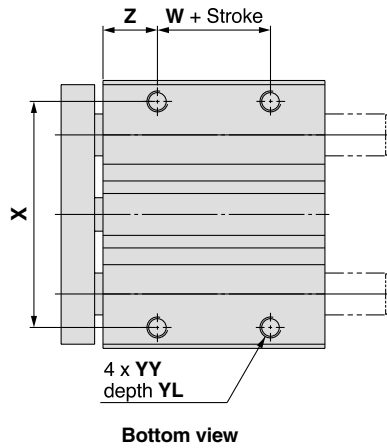

* The figures show when attached to SYJ3130-□G .
* [] : Denotes AC.

MVGQM, MVGQL Common Dimensions

Bore size (mm)	Standard stroke (mm)	Applicable solenoid valve	B	C	DA	G	GA		H	J	K	L	MM	ML	NN	Q	R	S	T	TA	TB	U	V	W	X	YY	YL	Z
							Up to 10 st	Over 10 st																				
12	10, 20, 30, 40, 50, 75, 100	Series SYJ3000	39	29	6	29	20	30	58	16	13	18	M4 x 0.7	10	M4 x 0.7	14	48	22	56	2	5	36	40	5	50	M4 x 0.7	7	12
16	20, 30, 40, 50, 75, 100, 125, 150, 175, 200		43	33	8	33	23	30	64	18	15	22	M5 x 0.8	13	M5 x 0.8	16	52	25	62	2.5	5.5	38	42	7	54	M5 x 0.8	8	13
20	20, 30, 40, 50, 75, 100, 125, 150, 175, 200		47	37	10	36	30	74	19	17	26	M5 x 0.8	13	M5 x 0.8	18	60	30	72	2	4	46	52	10	64	M5 x 0.8	8	13	

Note 1) It is possible to manufacture the intermediate strokes other than the standard strokes by means of installing a spacer.
Note 2) For the electrical entry except the grommet type, refer to page 1648.

MVGQM (Slide bearing) A, DB, E Dimensions

Bore size (mm)	Symbol	A		DB	E	
		Up to 50 st	Over 50 st		Up to 50 st	Over 50 st
12		39		8	0	
16		43		10	0	
20		47	61.5	12	0	14.5

MVGQL (Ball bushing bearing) A, DB, E Dimensions

Bore size (mm)	Symbol	A		DB	E	
		Up to 30 st	Over 30 st		Up to 30 st	Over 30 st
12		43	55	6	4	16
16		49	65	8	6	22
20		57	74	10	10	27

CV □
MVGQ

D-□
-X□
Individual
-X□

Valve Mounted Guide Cylinder

Series *MVGQ*

ø25, ø32, ø40, ø50, ø63



How to Order

How to Order

When ordering valve mounted guide cylinder, Series MVGQ, specify the models of both the cylinder and the valve.

Ex.) MVGQM25-30-M9BWM-B 1
 VZ3140-5LZ-MA 1

Cylinder stroke (mm)

Refer to page 1653 for standard strokes.

Bore size

25	25 mm	Series	40	40 mm	Series
32	32 mm	VZ3000	50	50 mm	VZ5000
			63	63 mm	

Bearing

M	Slide bearing
L	Ball bushing bearing

Auto switch

Nil	Without auto switch (Built-in magnet)
-----	---------------------------------------

* For the applicable auto switch model, refer to page 1653.

Number of auto switches

Nil	2 pcs.
S	1 pc.
n	n pcs.

Note)

Rod extended/retracted when energized

Nil	Rod extended when energized
B	Rod retracted when energized

Note) Based on the case of 2 position single solenoid valve.

Cylinder

MVGQ **M** **25** - **30** - **M9BW** [] - [] - []

Valve

VZ **3** **1** **4** **0** - **5** **L** [] [] - **MA** [] - []

Valve series

3	Series VZ3000
5	Series VZ5000

Type of actuation

1	2 position single solenoid
2	2 position double solenoid

* Please consult with SMC for 3 position type.

Body option

0: Pilot valve individual exhaust type

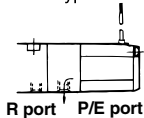

3: Main/Pilot valve common exhaust type

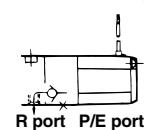

Rated voltage

1	100 VAC 50/60 Hz
2	200 VAC 50/60 Hz
3*	110 VAC 50/60 Hz
4*	220 VAC 50/60 Hz
5	24 VDC
6*	12 VDC
9*	Other

* Option

Speed controller specifications

MA	Meter-out
MB*	Meter-in

* Option

Made to Order

* Refer to page 1653 for details.

Port thread type

Nil	Rc
N	NPT
F	G

Manual override

Nil: Non-locking push type

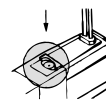

B: Locking type B (Slotted)

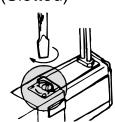

C: Locking type C (Manual)

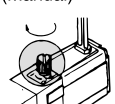

Light/Surge voltage suppressor

Nil	Without light/surge voltage suppressor
S	With surge voltage suppressor
Z (Note)	With light/surge voltage suppressor

Note) "GZ", "HZ" and "DOZ" are not available.

Electrical entry

Grommet	L plug connector	M plug connector		DIN terminal
G: Lead wire length: 300 mm	L: With lead wire (Wire length: 300 mm)	M: With lead wire (Wire length: 300 mm)	MN: Without lead wire	D: With connector
H: Lead wire length: 600 mm	LN: Without lead wire	LO: Without connector	MO: Without connector	DO: Without connector

* 2 sockets are attached to "LN" and "MN" types.

Valve Mounted Guide Cylinder *Series MVGQ*

JIS Symbol

Meter-out

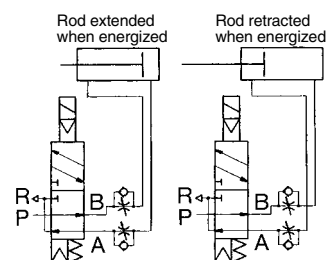

Meter-in (Option)

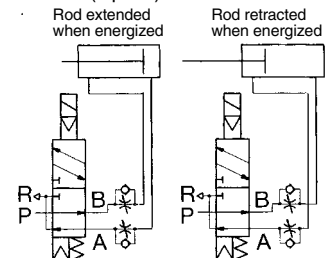

Specifications

Bore size (mm)	25, 32, 40, 50, 63	
Action	Double acting	
Fluid	Air	
Bearing type	Slide bearing (MVGQM), Ball bushing bearing (MVGQL)	
Operating pressure range (MPa)	2 position single	0.15 to 0.7
	2 position double	0.1 to 0.7
Ambient and fluid temperature (°C)	-10 to 50°C (No freezing)	
Piston speed (mm/s)	50 to 500 (Refer to the page 1643)	
Cushion	Rubber bumper on both ends	
Lubrication	Non-lube	
Stroke length tolerance (mm)	+1.5 0	

Solenoid Valve Specifications

Model	Series VZ3000/VZ5000		
Manual override	Non-locking push type, Locking slotted type, Locking lever type		
Pilot exhaust	Pilot valve individual exh. type, Main/Pilot valve common exh. type		
Mounting orientation	Universal		
Shock/Impact resistance (m/s ²) ⁽¹⁾	300/50		
Enclosure	Dust proof		
Electrical entry	Grommet (G)/(H), L plug connector (L), M plug connector (M), DIN terminal (D)		
Coil rated voltage (V)	AC50/60Hz	100, 200, 24*, 48*, 110*, 220*	
	DC	24, 6*, 12*, 48*	
Allowable voltage (%)	-15 to 10% of the rated voltage		
Power consumption (W) [Current: mA] ⁽²⁾	DC	1.8 (With indicator light: 2.1) [24 VDC: 75 (With light: 87.5)]	
Apparent power (VA) [Current: mA] ⁽²⁾	AC	Start-up	4.5 to 50 Hz, 4.2/60 Hz [100 VAC: 45/50 Hz, 42/60 Hz, 200 VAC: 22.5/50 Hz, 21/60 Hz]
		Holding	3.5/50 Hz, 3/60 Hz [100 VAC: 35/50 Hz, 30/60 Hz, 200 VAC: 17.5/50 Hz, 15/60 Hz]
Surge voltage suppressor	DC: Diode, AC: ZNR		
Indicator light	DC: LED (Red), AC: Neon bulb		

* Option

Note 1) Impact resistance:

No malfunction resulted from the impact test using a drop impact tester. The test was performed on the axis and right angle direction of the main valve and armature, one time each in both energized and de-energized states.

Vibration resistance: No malfunction occurred in a one-sweep test between 45 and 2000 Hz. Test was performed at both energized and de-energized states to the axis and right angle direction of the main valve and armature. (Value in the initial stage.)

Note 2) At the rated voltage.



Made to Order Specifications
(For details, refer to pages 1843 and 1847.)

Symbol	Specifications
-XA□	Change of guide rod end shape
-XC79	Tapped hole, drilled hole, pinned hole machined additionally

CV□

MVGQ

Standard Stroke

Model	Standard stroke (mm)	Intermediate stroke (mm)
MVGQ ^M 25	20, 30, 40, 50, 75, 100 125, 150, 175, 200	* As for the intermediate strokes (by the 1 stroke interval) for ø25, ø32 other than the standard strokes at left are manufactured by means of installing a spacer. Ex.) In the case of MVGQM25-21 st, an interface of 9 mm wide (5 mm + 4 mm) is installed inside of the MVGQ20-30 st, and thus the full length dimension of the body is the same as 30 st.
MVGQ ^M 32, 40 L 50, 63	25, 50, 75, 100, 125, 150, 175, 200	* As for the intermediate strokes (by the 5 stroke interval) for ø40 to ø63 other than the standard strokes at left are manufactured by means of installing a spacer. Ex.) In the case of MVGQM50-40 st, an interface of 10 mm wide is installed inside of the MVGQ50-50 st, and thus the full length dimension of the body is the same as 50 st.

Applicable Auto Switch/Refer to pages 1719 to 1827 for further information on auto switches.

Type	Special function	Electrical entry	Indicator light	Wiring (Output)	Load voltage		Auto switch model		Lead wire length (m)				Pre-wired connector	Applicable load		
					DC	AC	Perpendicular	In-line	0.5 (Nil)	1 (M)	3 (L)	5 (Z)				
Solid state switch	Diagnostic indication (2-color indication)	Grommet	Yes	3-wire (NPN)	24 V	5 V, 12 V	—	M9NV	M9N	●	●	○	○	IC circuit	Relay, PLC	
				3-wire (PNP)				M9PV	M9P	●	●	○	○			
				2-wire				M9BV	M9B	●	●	○	○			—
				3-wire (NPN)				M9NWV	M9NW	●	●	○	○			IC circuit
				3-wire (PNP)				M9PWV	M9PW	●	●	○	○			—
				2-wire				M9BWV	M9BW	●	●	○	○			—
Reed switch	—	Grommet	No	3-wire (NPN equivalent)	24 V	5 V	12 V	A96V	A96	●	—	●	—	—	IC circuit	—
				2-wire				A93V	A93	●	—	●	—	—	—	Relay, PLC
								A90V	A90	●	—	●	—	—	IC circuit	Relay, PLC

* Lead wire length symbols: 0.5 m Nil (Example) M9NW
1 m M (Example) M9NWM
3 m L (Example) M9NWL
5 m Z (Example) M9NWZ

* Solid state auto switches marked with "○" are produced upon receipt of order.

* Since there are other applicable auto switches than listed, refer to page 1665 for details.

* For details about auto switches with pre-wired connector, refer to pages 1784 and 1785.

* Auto switches are shipped together (not assembled).

D-□

-X□

Individual

-X□

Series MVGQ

Mass

(kg)

Bearing type	Bore size (mm)	Model	Standard stroke (mm)										
			20	25	30	40	50	75	100	125	150	175	200
Slide bearing	25	MVGQM25	0.96	-	1.06	1.17	1.26	1.57	1.81	2.05	2.29	2.53	2.77
	32	MVGQM32	-	1.64	-	-	2.04	2.42	2.82	3.22	3.62	4.02	4.42
Ball bushing bearing	25	MVGQL25	0.97	-	1.06	1.21	1.30	1.50	1.71	1.92	2.13	2.34	2.55
	32	MVGQL32	-	1.45	-	-	1.80	2.22	2.58	2.94	3.30	3.66	4.02

The allowable lateral load, the allowable rotational torque for a plate, and the operation range of a stopper are the same as those of Series MGQ. For details, refer to pages 337 to 351.

Note) The factors indicated above are of the single solenoid with grommet (G). Add 0.05 kg for the double solenoids.

Changing between Rod Extended when Energized and Rod Retracted when Energized

VZ3000

How to Handle Speed Controller

It is able to switch between rod extended when energized and rod retracted when energized by the mounting orientation of the selector plate.

When the coil (B side coil) of the single solenoid valve is energized, the cylinder will move in the \rightarrow direction.

The installed orientation of the adapter can be changed 180°. Refer to Fig. (2), which shows the relationship of the installed orientation of the selector plate adapter. Ordinarily, the speed controller is shipped as shown in Fig. (2) (a) or (b). But if you would like to change the orientation of speed controllers, use them in (c) or (d) shown in Fig. (2).

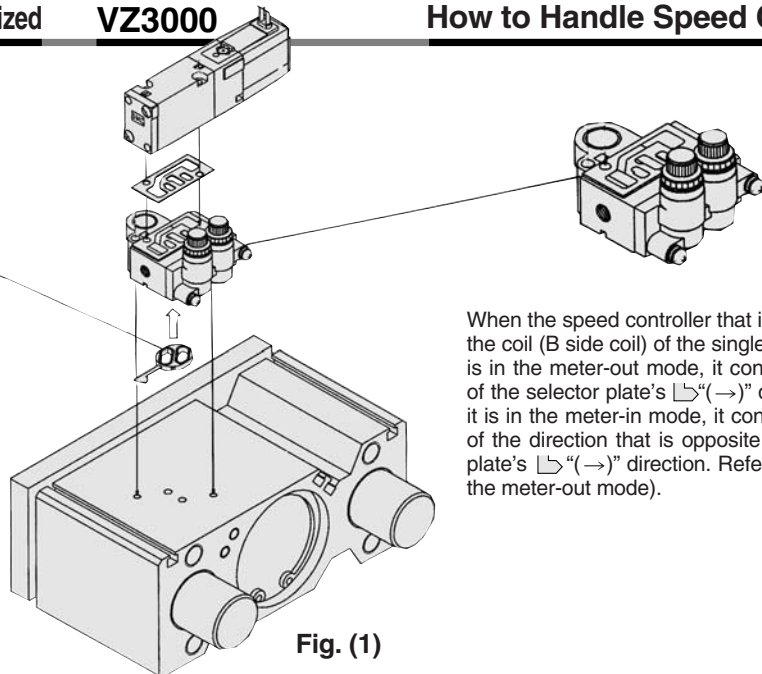

Fig. (1)

When the speed controller that is on the side of the coil (B side coil) of the single solenoid valve is in the meter-out mode, it controls the speed of the selector plate's \rightarrow direction. When it is in the meter-in mode, it controls the speed of the direction that is opposite to the selector plate's \rightarrow direction. Refer to Fig. (3) (for the meter-out mode).

Fig. (2)

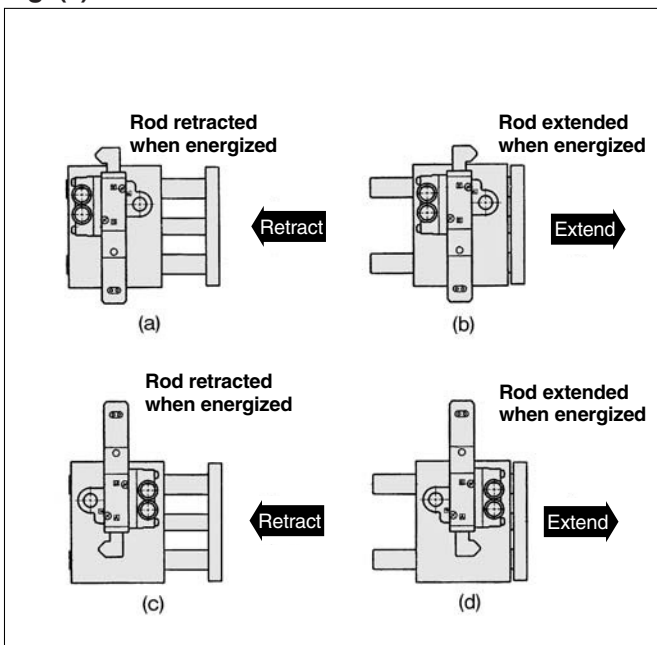
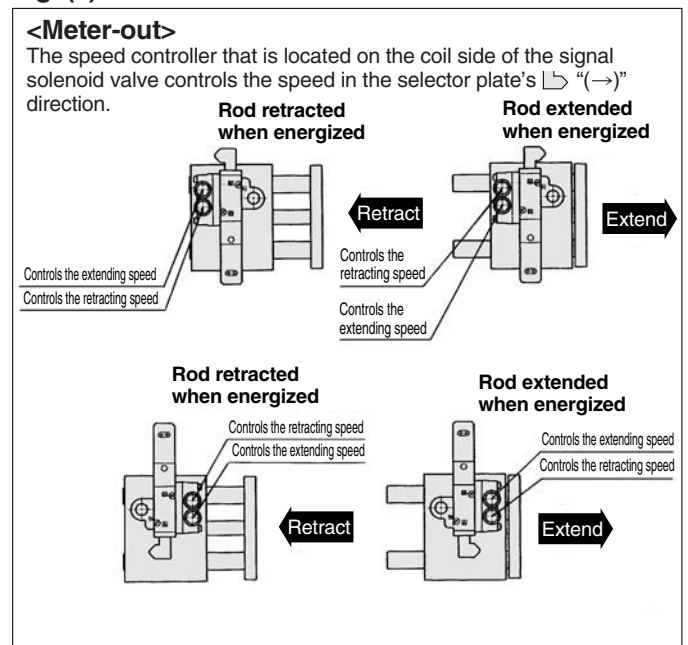

Fig. (3)



Mass

(kg)

Bearing type	Bore size (mm)	Model	Standard stroke (mm)							
			25	50	75	100	125	150	175	200
Slide bearing	40	MVGQM40	1.91	2.50	2.72	3.13	3.54	3.95	4.36	4.77
	50	MVGQM50	2.80	3.35	3.91	4.47	5.03	5.59	6.15	6.71
	63	MVGQM63	3.27	3.89	4.49	5.11	5.73	6.35	6.97	7.59
Ball bushing bearing	40	MVGQL40	1.72	2.08	2.53	2.89	3.25	3.61	3.97	4.33
	50	MVGQL50	2.37	2.85	3.45	3.94	4.43	4.92	5.41	5.90
	63	MVGQL63	2.91	3.45	4.11	4.65	5.19	5.73	6.27	6.81

(Note) The factors indicated above are of the single solenoid with grommet (G). Add 0.04 kg for the double solenoids.

Changing between Rod Extended when Energized and Rod Retracted when Energized

VZ5000

How to Handle Speed Controller

It is able to switch between rod extended when energized and rod retracted when energized by the mounting orientation of the selector plate. When the coil that is located in the selector plate's \rightarrow (\uparrow) direction is energized, the cylinder moves into the extension side. The valve orientation can also be changed 180°. Refer to Fig. (5), which shows the relationship between the selector plate and the installed orientation of the valve.

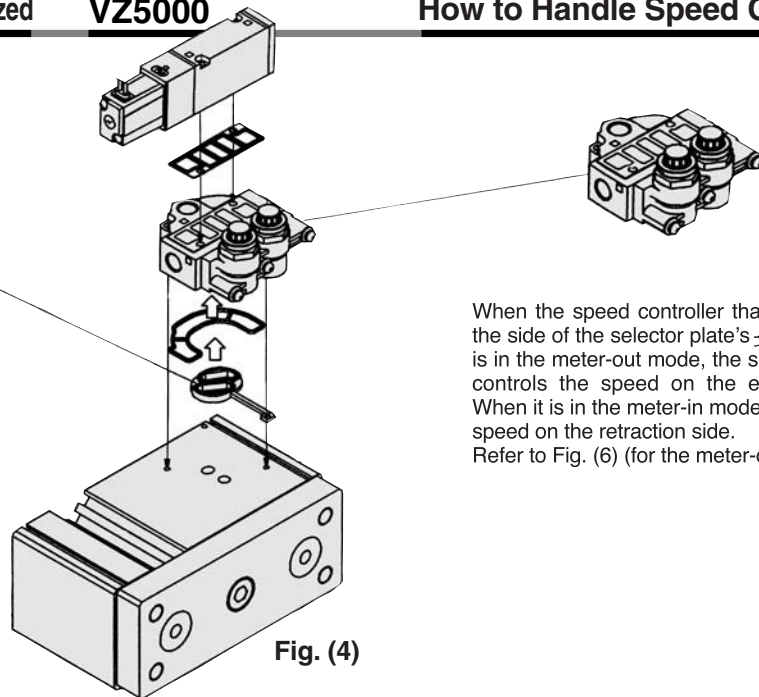

Fig. (4)

When the speed controller that is located on the side of the selector plate's \rightarrow (\uparrow) direction is in the meter-out mode, the speed controller controls the speed on the extension side. When it is in the meter-in mode, it controls the speed on the retraction side. Refer to Fig. (6) (for the meter-out mode).

Fig. (5)

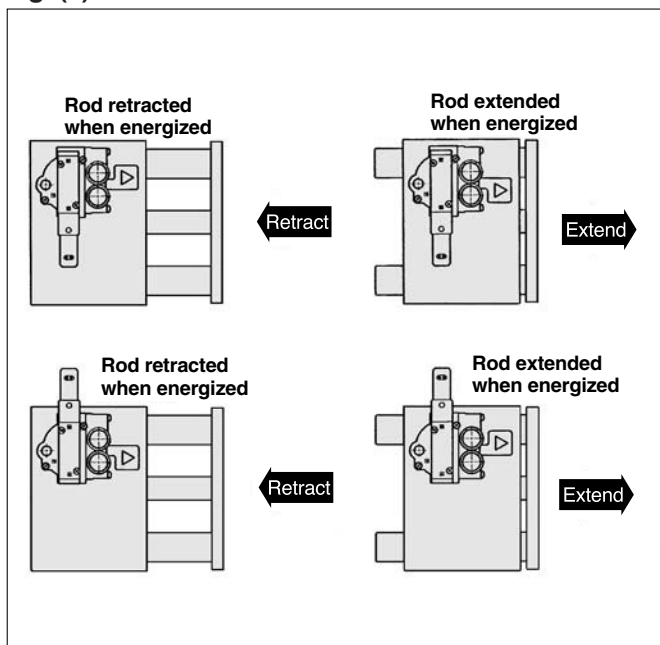
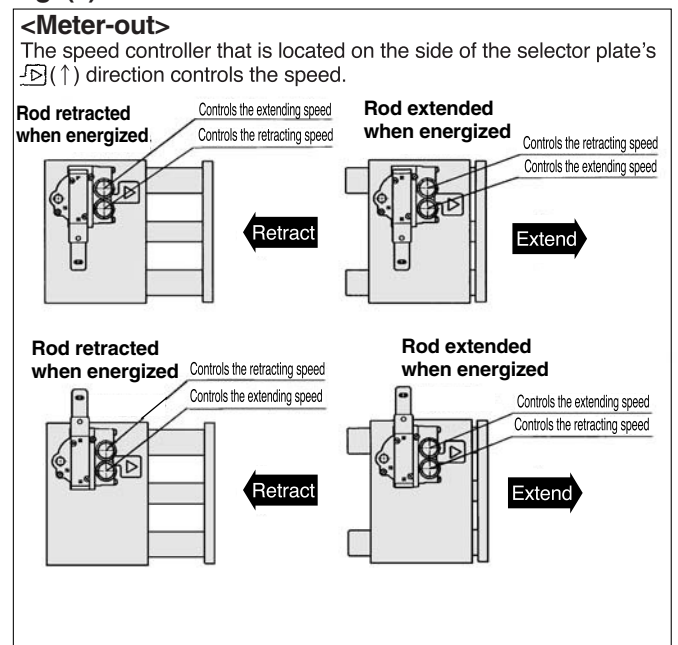

Fig. (6)



CV

MVGQ

D-

-X

Individual
-X

Series MVGQ

ø25, ø32

MVGQM, MVGQL

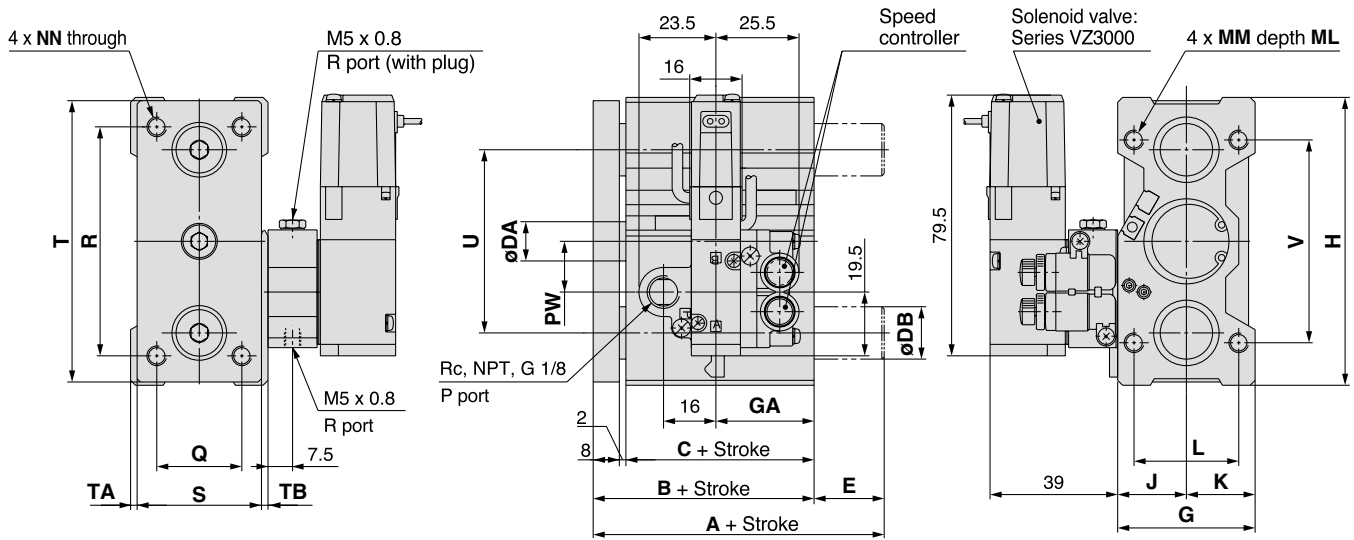
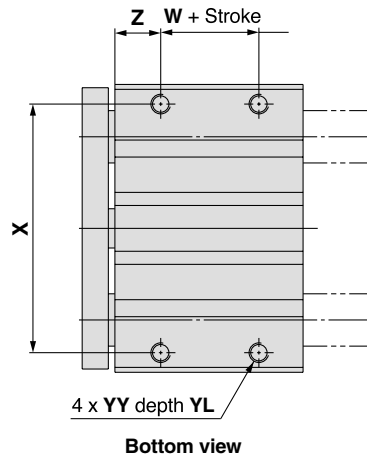

* The figures show when attached to VZ3140-□G .
* [] : Denotes AC.

MVGQM, MVGQL Common Dimensions

Bore size (mm)	Standard stroke (mm)	Applicable solenoid valve	B	C	DA	G	GA		H	J	K	L	MM	ML	NN	PW	Q	R	S	T	TA	TB	U	V	W	X	YY	YL	Z
							20 st	Over 20 st																					
25	20, 30, 40, 50, 75, 100, 125, 150, 175, 200	Series VZ3000	47.5	37.5	12	42	30	35	88	21	21	32	M6 x 1.0	15	M6 x 1.0	15.5	26	70	38	86	2	2	56	62	10	76	M6 x 1.0	9	14
							35	35																					
32	25, 50, 75, 100, 125, 150, 175, 200	Series VZ3000	47.5	37.5	16	51	35	35	114	25	26	38	M8 x 1.25	20	M8 x 1.25	22	30	96	48	112	2	1	80	80	5	100	M8 x 1.25	11	16
							35	35																					

Note 1) It is possible to manufacture the intermediate strokes other than the standard strokes by means of installing a spacer.

Note 2) For the electrical entry except the grommet type, refer to page 1652.

MVGQM (Slide bearing) A, DB, E Dimensions

Bore size (mm)	Symbol	A		DB	E	
		Up to 50 st	Over 50 st		Up to 50 st	Over 50 st
25	Stroke	47.5	62	16	0	14.5
		71.5			20	24

MVGQL (Ball bushing bearing) A, DB, E Dimensions

Bore size (mm)	Symbol	A		DB	E	
		Up to 30 st	Over 30 st		Up to 30 st	Over 30 st
25	Stroke	63.5	79.5	13	16	32
		53	90		16	5.5

Valve Mounted Guide Cylinder *Series MVGQ*

ø40, ø50, ø63

MVGQM, MVGQL

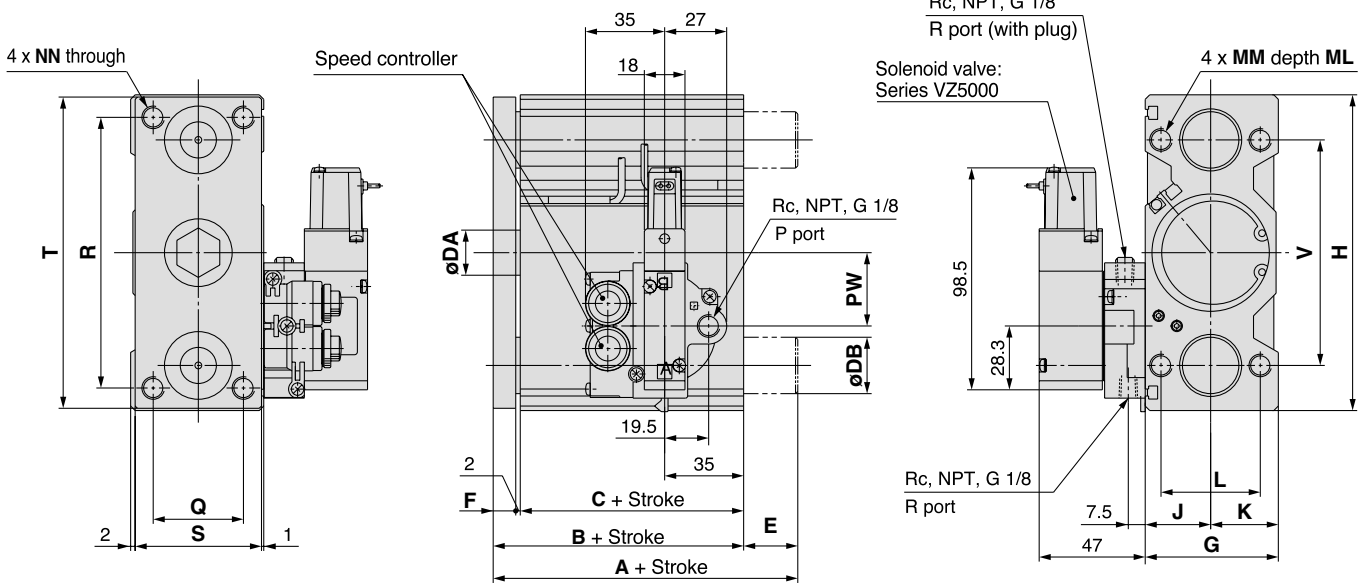
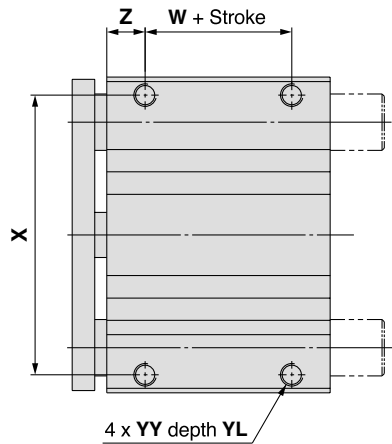

* The figures show when attached to VZ5140-□G .

MVGQM, MVGQL Common Dimensions

(mm)

Bore size (mm)	Standard stroke (mm)	Applicable solenoid valve	B	C	DA	F	G	H	J	K	L	MM	ML	NN	PW	Q	R	S	T	V	W	X	YY	YL	Z
40	25, 50, 75, 100, 125, 150, 175, 200	Series VZ5000	54	44	16	8	51	124	25	26	38	M8 x 1.25	20	M8 x 1.25	27	30	106	48	122	90	10	110	M8 x 1.25	11	17
50			56	44	20	10	59	140	29	30	44	M10 x 1.5	25	M10 x 1.5	32.5	40	120	56	138	100	10	124	M10 x 1.5	125	17
63			61	49	20	10	72	150	35.5	36.5	44	M10 x 1.5	25	M10 x 1.5	29.8	50	130	69	148	110	10	132	M10 x 1.5	15	19

Note 1) It is possible to manufacture the intermediate strokes other than the standard strokes by means of installing a spacer.

Note 2) For the electrical entry except the grommet type, refer to page 1652.

MVGQM (Slide bearing) A, DB, E Dimensions

Bore size (mm)	Symbol	A	DB	E
40		71.5	20	17.5
50		81	25	25
63		81	25	20

MVGQL (Ball bushing bearing) A, DB, E Dimensions

Bore size (mm)	Stroke	A		DB	E	
		Up to 50 st	Over 50 st		Up to 50 st	Over 50 st
40	Up to 50 st	54	90	16	0	36
	Over 50 st	60	102		4	46
50	Up to 50 st	60	102	20	0	41
	Over 50 st	61	102		0	41

CV □

MVGQ

D-□

-X□

Individual
-X□

Valve Mounted Guide Cylinder

Series *MVGQ*

ø80, ø100

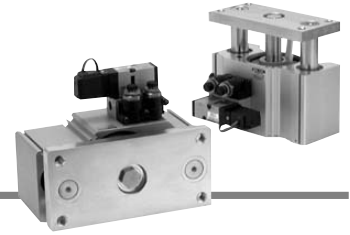

How to Order

How to Order

When ordering valve mounted guide cylinder, Series MVGQ, specify the models of both the cylinder and the valve.

Ex.) MVGQM80-50-M9BWM-B 1
VF3140-5LZ-MA 1

Cylinder stroke (mm)
Refer to page 1659 for standard strokes.

Bore size

80	80 mm
100	100 mm

Bearing

M	Slide bearing
L	Ball bushing bearing

Auto switch

Nil	Without auto switch (Built-in magnet)
-----	---------------------------------------

* For the applicable auto switch model, refer to page 1659.

Number of auto switches

Nil	2 pcs.
S	1 pc.
n	n pcs.

Rod extended/retracted when energized (Note)

Nil	Rod extended when energized
B	Rod retracted when energized

Note) Based on the case of 2 position single solenoid valve.

Speed controller specifications

MA	Meter-out
MB*	Meter-in

* Option

Port thread type

Nil	Rc
N	NPT
F	G

Manual override

Nil: Non-locking push type Manual override

B: Locking type B (Slotted) Manual override

C: Locking type C (Manual) Manual override

Light/Surge voltage suppressor

Nil	Without light/surge voltage suppressor
S ⁽¹⁾	With surge voltage suppressor
Z ⁽²⁾	With light/surge voltage suppressor

Note 1) Applicable to the grommet type only.
Note 2) "GZ", "HZ" are not available.

Electrical entry

G	Grommet (Lead wire length: 300 mm)	L	L plug connector	With lead wire
H	Grommet (Lead wire length: 600 mm)	LO	LO plug connector	Without connector
E	Grommet terminal	M	M plug connector	With lead wire
T	Conduit terminal	MO	MO plug connector	Without connector
		D	DIN terminal	With connector
		DO	DO terminal	Without connector

Cylinder MVGQ M 80 - 50 - M9BW

Valve VF3 1 4 0 - 5 LZ - MA

Type of actuation

1	2 position single solenoid
2	2 position double solenoid

* Please consult with SMC for 3 position type.

Body option

0: Pilot valve individual exhaust type

3: Main/Pilot valve * common exhaust type

Rated voltage

1	100 VAC, 50/60 Hz
2	200 VAC, 50/60 Hz
3*	110 to 120 VAC, 50/60 Hz
4*	220 VAC, 50/60 Hz
5	24 VDC
6*	12 VDC
7*	240 VAC, 50/60 Hz
9*	Other

Maximum rated voltage for L/M type plug connectors is 220 VAC.
* Option

Diagram 0: Pilot valve individual exhaust type. Shows R port and P/E port.

Diagram 3: Main/Pilot valve * common exhaust type. Shows R port and P/E port.

* Option

Valve Mounted Guide Cylinder *Series MVGQ*

JIS Symbol

Meter-out

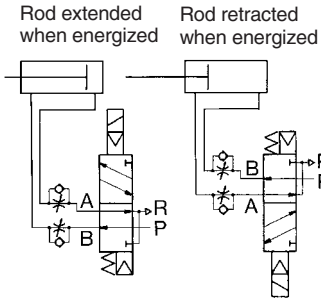

Meter-in (Option)

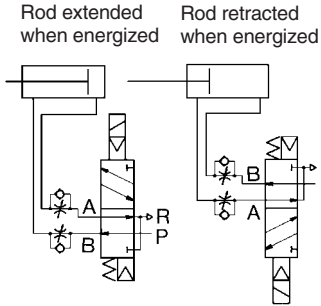

Specifications

Bore size (mm)	80, 100	
Action	Double acting	
Fluid	Air	
Bearing type	Slide bearing (MVGQM), Ball bushing bearing (MVGQL)	
Operating pressure range (MPa)	2 position single	0.15 to 0.9
	2 position double	0.1 to 0.9
Ambient and fluid temperature (°C)	-10 to 50°C (No freezing)	
Piston speed (mm/s)	50 to 350 (Refer to the page 1643)	
Cushion	Rubber bumper on both ends	
Lubrication	Non-lube	
Stroke length tolerance (mm)	+1.5 0	

Solenoid Valve Specifications

Model	Series VF3000		
Manual override	Non-locking push type, Locking B type*, Locking C type*		
Pilot exhaust	Pilot valve individual exh. type, Main/Pilot valve common exh. type		
Mounting orientation	Universal		
Shock/Impact resistance (m/s ²) ⁽¹⁾	300/50		
Enclosure	Dustproof		
Electrical entry	Grommet, Grommet terminal, Conduit terminal, DIN terminal, L plug connector, M plug connector		
Coil rated voltage (V)	AC50/60 Hz	100, 200, 12*, 24*, 48*, 110*, 220*, 240*	
	DC	24, 6*, 12*, 48*, 100*, 110*	
Allowable voltage	-15% to 10% of the rated voltage		
Apparent power ⁽²⁾	AC	Inrush	5.6 VA (50 Hz), 5.0 VA (60 Hz)
		Holding	3.4 VA (50 Hz), 2.3 VA (60 Hz)
Power consumption (W) ⁽²⁾	DC	1.8, 2 (With indicator light)	
	Light/Surge voltage suppressor	AC	ZNR (Varistor), Neon bulb (LED for less than 100 V)
		DC	ZNR (Varistor), LED (Neon bulb for 100 V or more)

Note 1) Impact resistance: No malfunction resulted from the impact test using a drop impact tester. The test was performed on the axis and right angle direction of the main valve and armature, one time each in both energized and de-energized states.



Vibration resistance: No malfunction occurred in a one-sweep test between 45 and 2000 Hz. Test was performed at both energized and de-energized states to the axis and right angle direction of the main valve and armature. (Value in the initial stage.)

Note 2) At the rated voltage.

* Option

Standard Stroke

Model	Standard stroke (mm)	Intermediate stroke (mm)
MVGQ^M_L 80/100	25, 50, 75, 100 125, 150, 175, 200	As for the intermediate strokes (by the 5 stroke interval) other than the standard strokes at left are manufactured by means of installing a spacer with the width of 5, 10, 15, 20 mm. Ex.) In the case of MVGQM80-40 st, an interface of 10 mm wide is installed inside of the MVGQM80-50 st, and thus the full length dimension of the body is the same as 50 st.

Applicable Auto Switch/Refer to pages 1719 to 1827 for further information on auto switches.

Type	Special function	Electrical entry	Indicator/light	Wiring (Output)	Load voltage		Auto switch model		Lead wire length (m)				Pre-wired connector	Applicable load		
					DC	AC	Perpendicular	In-line	0.5 (Nil)	1 (M)	3 (L)	5 (Z)		IC circuit	Relay, PLC	
Solid state switch	Diagnostic indication (2-color indication)	Grommet	Yes	3-wire (NPN)	24 V	5 V, 12 V	—	M9NV	M9N	●	●	○	○	—	Relay, PLC	
				3-wire (PNP)				M9PV	M9P	●	●	○	○			
				2-wire				M9BV	M9B	●	●	○	○			—
				3-wire (NPN)				M9NWV	M9NW	●	●	○	○			
				3-wire (PNP)				M9PWV	M9PW	●	●	○	○			
				2-wire				M9BWV	M9BW	●	●	○	○			
Reed switch	—	Grommet	Yes	3-wire (NPN equivalent)	24 V	5 V	—	A96V	A96	●	—	●	—	—	—	
				2-wire				100 V	A93V	A93	●	—	●	—	—	—
								100 V or less	A90V	A90	●	—	●	—	—	—

* Lead wire length symbols: 0.5 m Nil (Example) M9NW
1 m M (Example) M9NWM
3 m L (Example) M9NWL
5 m Z (Example) M9NwZ

* Solid state auto switches marked with "○" are produced upon receipt of order.

* Since there are other applicable auto switches than listed, refer to page 1665 for details.
* For details about auto switches with pre-wired connector, refer to pages 1784 and 1785.
* Auto switches are shipped together (not assembled).

Series MVGQ

Mass

(kg)

Bearing type	Bore size (mm)	Model	Standard stroke (mm)							
			25	50	75	100	125	150	175	200
Slide bearing	80	MVGQM80	6.15	7.08	7.98	8.90	9.82	10.73	11.66	12.58
	100	MVGQM100	9.45	10.76	12.06	13.39	14.72	16.05	17.38	18.71
Ball bushing bearing	80	MVGQL80	5.98	6.87	8.44	9.28	10.12	10.96	11.80	12.64
	100	MVGQL100	8.83	10.02	12.27	13.45	14.63	15.81	16.99	18.17

Note) The factors indicated above are of the single solenoid with grommet (G). Add 0.08 kg for the double solenoids.

The allowable lateral load, the allowable rotational torque for a plate, and the operation range of a stopper are the same as those of Series MGQ. For details, refer to pages 337 to 351.

Changing between Rod Extended when Energized and Rod Retracted when Energized

It is able to switch between rod extended when energized and rod retracted when energized by the mounting orientation of the valve. Refer to Fig. (2).

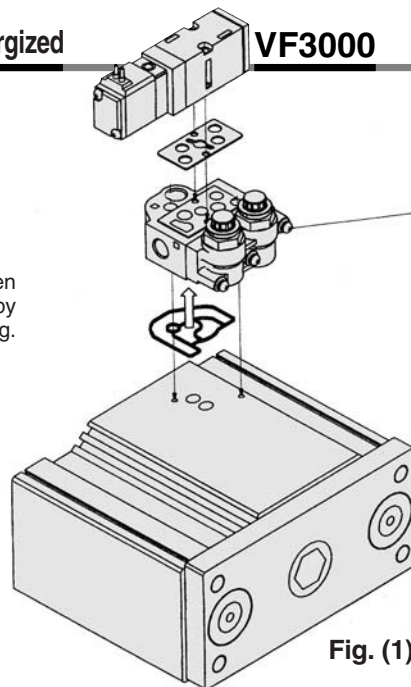
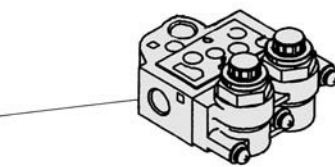

Fig. (1)

How to Handle Speed Controller



Coil (coil in A side) of the single solenoid valve and the speed controller in the opposite side at the rod extended when energized control the extending speed at meter-out and the retracting speed at meter-in. Refer to Fig. (3).

Fig. (2)

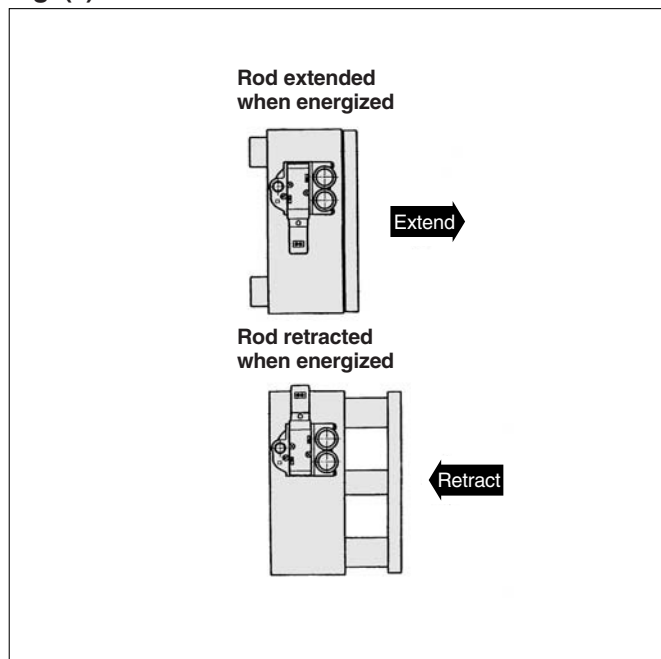
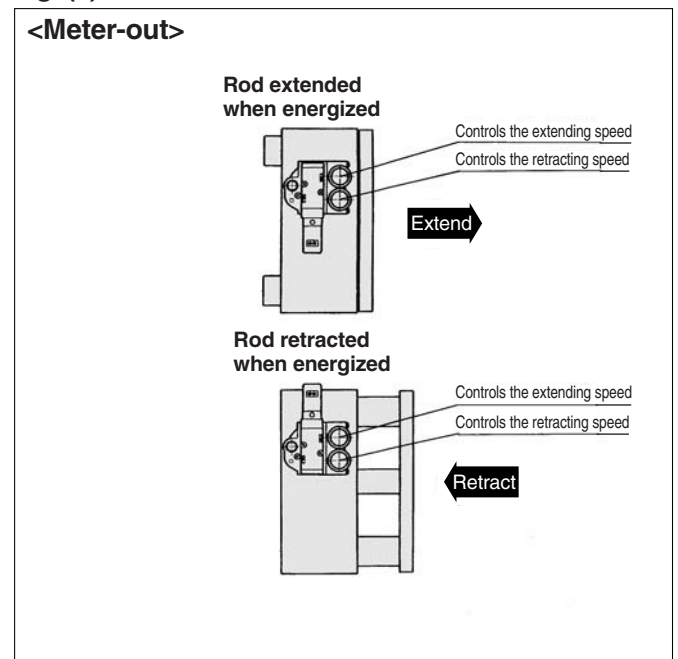

Fig. (3)



Valve Mounted Guide Cylinder *Series MVGQ*

ø80, ø100

MVGQM, MVGQL

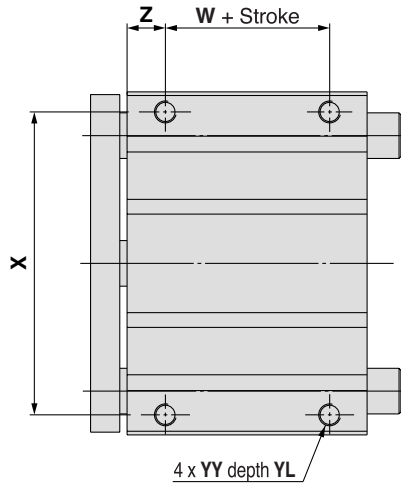

Bottom view

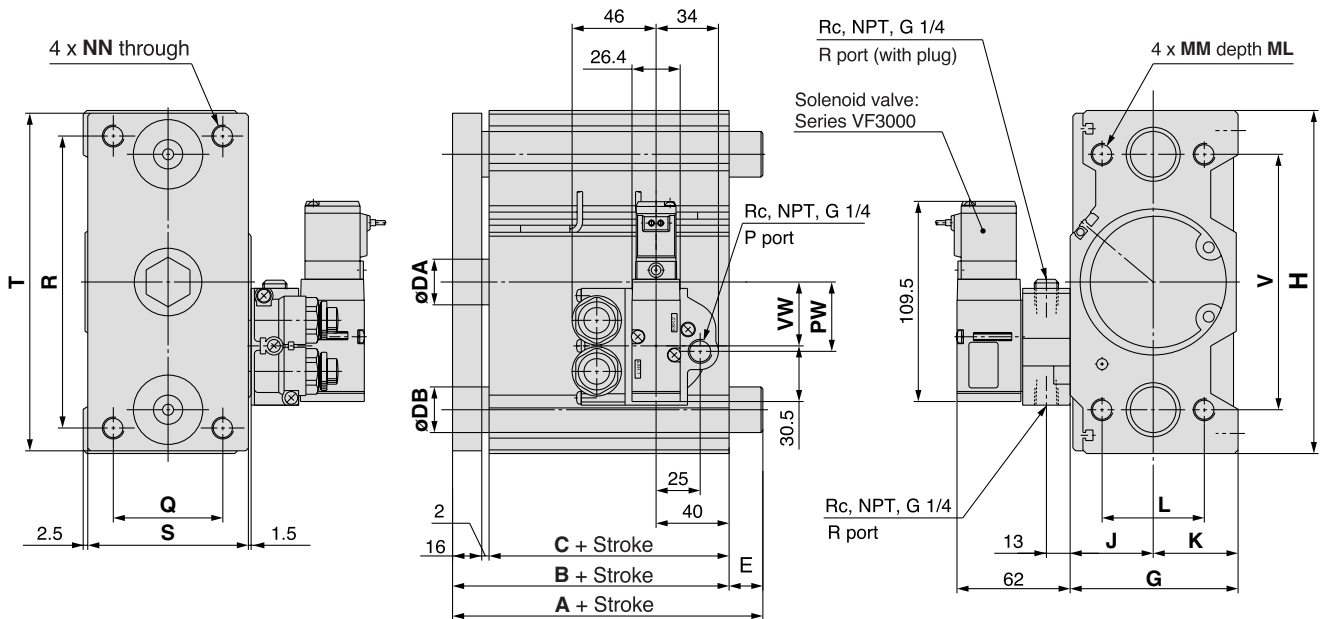

* The figures show when attached to VF3140-□G.

MVGQM, MVGQL Common Dimensions

Bore size (mm)	Standard stroke (mm)	Applicable solenoid valve	B	C	DA	G	GA	H	J	K	L	MM	ML	NN	VWPW	Q	R	S	T	V	W	X	YY	YL	Z	
80	25, 50, 75, 100,	Series VF3000	74.5	56.5	25	92	40	188	45.5	46.5	56	M12X1.75	30	M12 x 1.75	35	38	60	160	88	185	140	15	166	M12 x 1.75	18	21
100	125, 150, 175, 200		84	66	30	112	40	224	55.5	56.5	62	M14X2	35	M14 x 2	41	44	80	190	108	221	170	15	200	M14 x 2	21	25



Note 1) It is possible to manufacture the intermediate strokes other than the standard strokes by means of installing a spacer.
 Note 2) For the electrical entry except the grommet type, refer to page 1658.

MVGQM (Slide bearing) A, DB, E Dimensions

Bore size (mm)	Symbol	Dimensions		
		A	DB	E
80		93	28	18.5
100		105	36	21

MVGQL (Ball bushing bearing) A, DB, E Dimensions

Bore size (mm)	Symbol	A		DB	E	
		Up to 50 st	Over 50 st		Up to 50 st	Over 50 st
		80	84	143	25	9.5
100	89	153	30	5	69	

CV □
MVGQ

D-□
-X□
Individual
-X□

Series MVGQ

Construction

Series MVGQM

MVGQM12 to 25

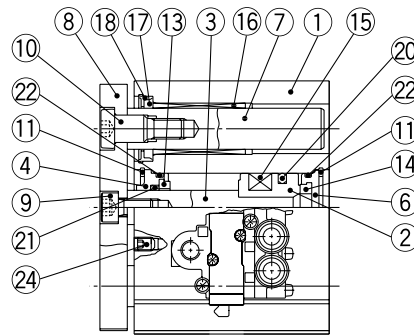

50 stroke or less

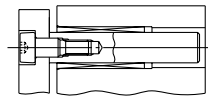

ø12, ø16

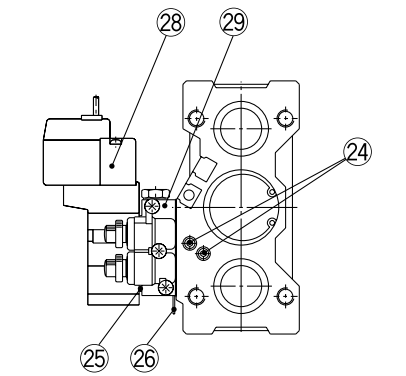

ø20, ø25 Over 50 stroke

MVGQM32 to 100

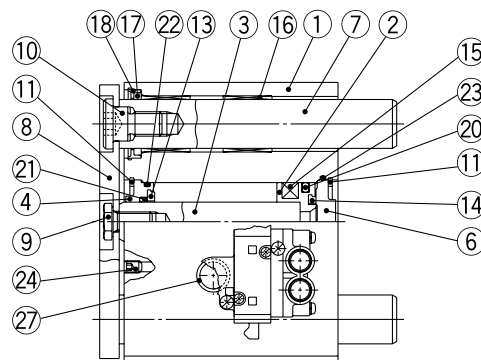

ø50 or more

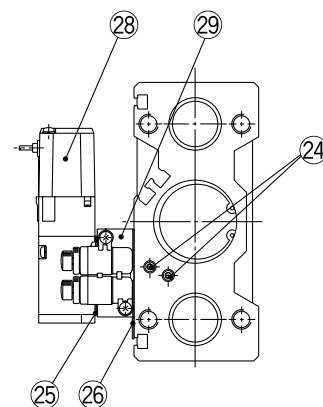

Component Parts

No.	Description	Material	Note
1	Body	Aluminum alloy	Hard anodized
2	Piston	Aluminum alloy	Chromated
3	Piston rod	Stainless steel	ø12 to ø25
		Carbon steel	ø32 to ø100
4	Collar	Aluminum alloy	ø12 to ø40
		Aluminum alloy casted	ø50 to ø100
5	Bushing	Special friction material	ø50 to ø100
6	Head cover	Aluminum alloy	ø12 to ø63
			ø80 to ø100
7	Guide rod	Carbon steel	Hard chrome plated
8	Plate	Carbon steel	Nickel plated
9	Plate mounting bolt	Carbon steel	Nickel plated
10	Guide bolt	Carbon steel	Nickel plated
11	Retaining ring	Carbon tool steel	Phosphate coated
12	Retaining ring	Carbon tool steel	Phosphate coated

No.	Description	Material	Note
13	Bumper A	Urethane	
14	Bumper B	Urethane	
15	Magnet	-	
16	Slide Bearing	Special friction material	
17	Felt	Felt	
18	Holder	Resin	
19	Ball bushing		
20	Piston seal	NBR	
21	Rod seal	NBR	
22	Gasket A	NBR	
23	Gasket B	NBR	
24	Hexagon socket head cap screw	Carbon steel	Nickel plated
25	Manifold gasket		
26	Selector plate		ø12 to ø63 only
27	Adapter gasket		ø25 to ø100 only
28	Solenoid valve		
29	Adapter assembly		

Series MVGQL

MVGQL12 to 25

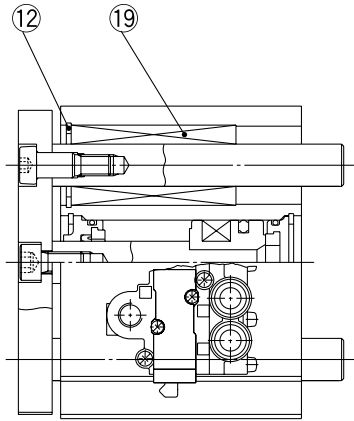

30 stroke or less

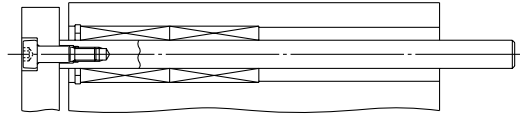

ø12, ø16: Over 30 stroke

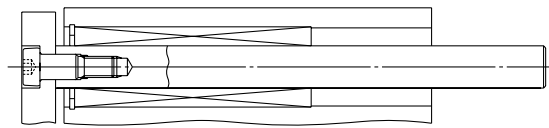

ø20, ø25: Over 30 stroke

MVGQL32 to 100

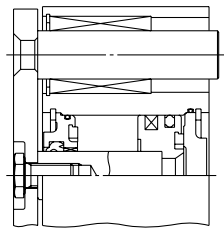
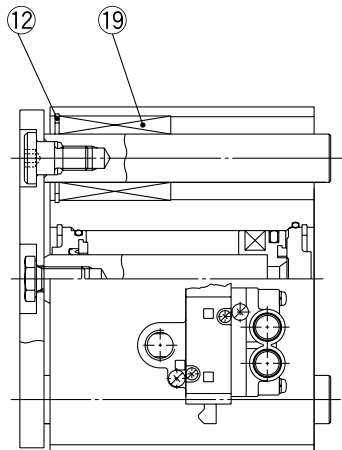

50 stroke or more

CV
MVGQ

Replacement Parts

No.	Description	Kit no.									
		ø12	ø16	ø20	ø25	ø32	ø40	ø50	ø63	ø80	ø100
19 to 20	Seal kit	MGQ12-PS	MGQ16-PS	MGQ20-PS	MGQ25-PS	MGQ32-PS	MGQ40-PS	MGQ50-PS	MGQ63-PS	MGQ80-PS	MGQ100-PS
25 to 29	Solenoid valve with adapter assembly	SYJ3□3-□□□□-M ₆			VZ3□4□-□□□□-M ₆ □		VZ5□4□-□□□□-M ₆ □			VF3□4□-□□□□-M ₆ □	



Note 1) Seal kit includes ⑱ to ㉓. Order the seal kit, based on each bore size.

Note 2) For the specifying way of ordering numbers for the solenoid valve with adapter assembly, refer to pages 1648, 1652 and 1658.

* Since the seal kit does not include a grease pack, order it separately.

Grease pack part no.: GR-S-010 (10 g)

Port thread type ●

Nil	Rc
N	NPT
F	G

D-

-X

Individual
-X

Series **MVGQ**

Auto Switch Proper Mounting Position (Detection at Stroke End)

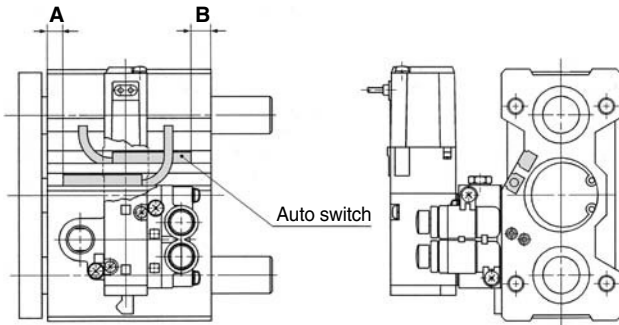

Auto Switch Proper Mounting Position (mm)

Auto switch model	D-M9□ D-M9□V D-M9□W D-M9□WV		D-A9□ D-A9□V		D-Z7□/Z80 D-Y59□/Y7P D-Y69□/Y7PV D-Y7□W D-Y7□WV	
	A	B	A	B	A	B
12	6	8	2	4	1	3
16	9	9	5	5	4	4
20	9.5	12.5	5.5	8.5	4.5	7.5
25	9.5	13	5.5	9	4.5	8
32	10.5	12	6.5	8	5.5	7
40	14.5	14.5	10.5	10.5	9.5	9.5
50	12.5	16.5	8.5	12.5	7.5	11.5
63	15	19	11	15	10	14
80	18	23.5	14	19.5	13	18.5
100	22.5	28.5	18.5	24.5	17.5	23.5

Note) Adjust the auto switch after confirming the operating conditions in the actual setting.

Minimum Stroke for Auto Switch Mounting

Auto switch model	No. of auto switches mounted	ø12	ø16	ø20	ø25	ø32	ø40	ø50	ø63	ø80	ø100	
D-A9□	1 pc.	10			5							
	2 pcs.	15			10							
D-A9□V D-M9□V	1 pc.	5										
	2 pcs.	10										
D-M9□	1 pc.	15	10			5						
	2 pcs.	15				10						
D-M9□W	1 pc.	15				10						
	2 pcs.	15				10						
D-M9□WV	1 pc.	10										
	2 pcs.	10										
D-Z7□ D-Z80	1 pc.	10			5							
	2 pcs.	15				10						
D-Y59□ D-Y7P	1 pc.	10			5							
	2 pcs.	15				10						
D-Y69□ D-Y7PV	1 pc.	5										
	2 pcs.	5										
D-Y7□W D-Y7□WV	1 pc.	10										
	2 pcs.	15										

Operating Range

Auto switch model	Bore size (mm)									
	12	16	20	25	32	40	50	63	80	100
D-A9□/A9□V	7	9.5	9	9	9	9	9	10.5	10	10.5
D-M9□/M9□V D-M9□W/M9□WV	4	5.5	5	5	5.5	5	5.5	5.5	6.5	7
D-Z7□/Z80□	7.5	8.5	9.5	9.5	11	11	11	13	13	14
D-Y59□/Y69□ D-Y7P/Y7PV D-Y7□W/Y7□WV	5	6	6	6.5	8.5	8.5	9	10	10	11.5

* Since this is a guideline including hysteresis, not meant to be guaranteed. (Assuming approximately ±30% dispersion)
There may be the case it will vary substantially depending on an ambient environment.

Auto Switch Mounting Bracket: Part No.

Auto switch model	Bore size (mm)
D-A9□/A9□V D-M9□/M9□V D-M9□W/M9□WV	BMG2-012

• D-A9□(V), M9□(V), M9□W(V)

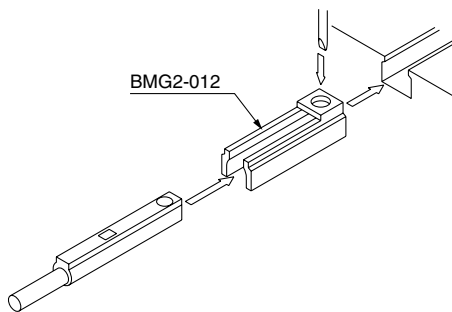

Other than the models listed in "How to Order", the following auto switches are applicable.
For detailed specifications, refer to pages 1719 to 1827.

Auto switch type	Model	Electrical entry (Fetching direction)	Features
Reed	D-Z73, Z76	Grommet (In-line)	—
	D-Z80		Without indicator light
Solid state	D-Y69A, Y69B, Y7PV	Grommet (Perpendicular)	—
	D-Y7NWV, Y7PWV, Y7BWV		Diagnostic indication (2-color)
	D-Y59A, Y59B, Y7P	Grommet (In-line)	—
	D-Y7NW, Y7PW, Y7BW		Diagnostic indication (2-color)

* For solid state auto switches, auto switches with a pre-wired connector are also available. Refer to pages 1784 and 1785 for details.

* Normally closed (NC = b contact), solid state auto switch (D-F9G/F9H/Y7G/Y7H type) are also available. For details, refer to pages 1746 and 1748.

CV□

MVGQ

D-□

-X□

Individual
-X□